



TECHNICAL DATA

SWING CHECK VALVE MODEL F-2 VDS APPROVED

The Viking Corporation, 210 N Industrial Park Road, Hastings MI 49058

Telephone: 269-945-9501 Technical Services 877-384-5464 Fax: 269-945-4495 Email: techsvcs@vikingcorp.com

1. PRODUCT DESCRIPTION

The Viking Swing Check Valve is a general purpose rubber-faced check valve approved for use in fire-service systems.

The Swing Check Valve is manufactured with a ductile iron body, brass seat, and a rubber-faced clapper assembly, hinged to a removable access cover for easy inspection and maintenance. For availability of flanged-flanged and grooved-grooved options, refer to Table 1. Tapped openings (with plugs) and gauge connections are provided on both the inlet and outlet chambers of the valve.

FEATURES

- Ductile iron body for less weight and extra strength.
- Rubber-faced clapper hinged to access cover for quick removal and easy servicing. All moving parts can be serviced without removing the valve from the installed position.
- With the cover assembly removed, the clapper rubber replacement requires removal of only one screw.
- Can be installed in the vertical position with direction of flow up, or in the horizontal position with the access cover up.

2. LISTINGS AND APPROVALS

Vds Approved

3. TECHNICAL DATA

Specifications:

Rated to 145 psi (10 BAR) water working pressure.

Factory tested hydrostatically to 500 psi (3 447 kPa).

Standard Flanged Connections: Flanged drilling according to ISO 2084/EN 1092/DIN 2501/PN16

Standard Grooved Connections: ANSI/AWWA C606

Tapped Bosses: Two 1/2" (15 mm) NPT

Material Standards:

(Refer to Figure 1 on page 805 d.)

Ordering Information:

See Table 1 for valve inlet and outlet configurations and part numbers

4. INSTALLATION

The Viking Swing Check Valve must be installed in an area not subject to physical damage. When corrosive atmospheres and/or contaminated water supplies are present, it is the owner's responsibility to verify compatibility with the swing check valve and associated equipment.

Prior to installing the valve, thoroughly flush the water supply piping to verify that no foreign matter is present.

Systems with water working pressures above 230 psi (16 BAR) may require extra-heavy pattern fittings. Viking Swing Check Valve flanges are ductile iron, drilled according to ISO2084/EN 1092/DIN 2501/PN16 and VdS approved up to a maximum water working pressure of 145 psi (10 BAR). For piping with grooved connections, the grooved-inlet/grooved-outlet style swing check valve may be installed with approved grooved couplings of the appropriate pressure rating.

Hydrostatic Test:

Check Valves may be hydrostatically tested at 195 psi (13 BAR) and/or 50 psi (3 BAR) above the normal water working pressure for limited periods of time (two hours) for the purpose of acceptance by the Authority Having Jurisdiction. If air testing is required, do not exceed 40 psi (2 BAR) air pressure.

5. OPERATION

(Refer to Figure 1 on page 805 d.)

Flow through the Viking Swing Check Valve lifts the rubber-gasketed clapper (10 and 12) off the seat (17) to enter the sprinkler piping. When flow through the valve stops, the clapper (10) closes quickly. The rubber gasket (12) forms a tight seal against the brass water seat (17), trapping pressure above the clapper and preventing reverse flow from sprinkler piping.

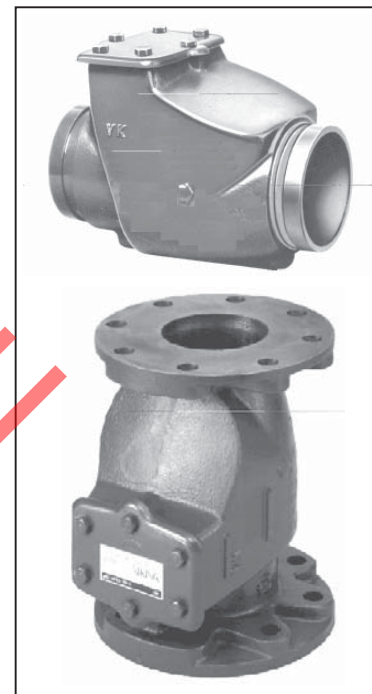

Viking Technical Data may be found on
The Viking Corporation's Web site at
<http://www.vikinggroupinc.com>.
The Web site may include a more recent
edition of this Technical Data Page.



TECHNICAL DATA

**SWING CHECK VALVE
MODEL F-2
VDS APPROVED**

The Viking Corporation, 210 N Industrial Park Road, Hastings MI 49058

Telephone: 269-945-9501 Technical Services 877-384-5464 Fax: 269-945-4495 Email: techsvcs@vikingcorp.com

6. INSPECTIONS, TESTS AND MAINTENANCE

NOTICE: The owner is responsible for maintaining the fire-protection system and devices in proper operating condition.

The Viking Swing Check Valve must be kept free of foreign matter, freezing conditions (when used on wet systems), corrosive atmospheres, contaminated water supplies, and any condition that could impair its operation or damage the device.

It is imperative that the system be inspected and tested on a regular basis. The frequency of the inspections may vary due to contaminated water supplies, corrosive water supplies, and corrosive atmospheres. For minimum maintenance and inspection requirements, refer to the National Fire Protection Association's pamphlet that describes care and maintenance of sprinkler systems. In addition, the Authority Having Jurisdiction may have additional maintenance, testing, and inspection requirements that must be followed.

WARNING: Any system maintenance which involves placing a control valve or detection system out of service may eliminate the fire-protection capabilities of that system. Prior to proceeding, notify all the Authority Having Jurisdiction. Consideration should be given to employment of a fire patrol in the affected areas.

6-A Five-Year Internal Inspection (Refer to Figure 1 on page 805 d)

Internal inspection of Swing Check Valves is recommended every five years unless inspections and tests indicate more frequent inspections are required.

1. Notify the Authority Having Jurisdiction, remote station alarm monitors, and those in the area affected that the system will be taken out of service. Consideration should be given to employment of a fire patrol in the affected areas.
2. Close the water supply main control valve, placing the system out of service.
3. Open the main drain. If necessary, open the system test valve to vent and completely drain the system.
4. Use the appropriate wrench to loosen and remove the cover screws (14), and remove the cover assembly (2).
5. Inspect the water seat (17). Wipe away all contaminants, dirt, and mineral deposits. DO NOT use solvents or abrasives.
6. Inspect the cover assembly (2) and the cover gasket (15). Test the hinged clapper for freedom of movement. Renew or replace damaged or worn parts as required.

CAUTION: NEVER apply any lubricant to seats, gaskets, or any internal operating parts of the valve. Petroleum-based grease or oil will damage rubber components and may prevent proper operation.

7. When Internal inspection of the check valve is complete, perform step 6 of paragraph **6-B Valve Maintenance** to re-install the cover assembly (2).

6-B Valve Maintenance

(Refer to Figure 1 on page 805 d.)

1. Perform steps 1 through 5 of paragraph **6-A Five-year Internal Inspection**.
2. To remove clapper rubber (12):
 - a. Use the appropriate wrenches to loosen and remove the button-head socket screw (8), hex nut (9), sealing washer (7), and rubber retainer (11).
 - b. Remove the clapper rubber (12) for inspection. If the clapper rubber shows signs of wear, such as cracking, cuts, or excessively deep grooves where the rubber contacts the water seat, replace the rubber.
3. To re-install clapper rubber (12):
 - a. Place the clapper rubber (12) over the center hub of the rubber retainer (11).
 - b. Position the retainer (11) (with rubber in place) against the clapper (10) as shown in Figure 1.
 - c. Replace and tighten the button-head socket screw (8), sealing washer (7), and hex nut (9). The sealing washer (7) and hex nut (9) must be located on the top side of the clapper as shown in Figure 1. Do not over-tighten.
4. To remove clapper (10), and/or hinge pin (4):
 - a. Remove the hinge pin retaining rings (5) to free the hinge pin (4) for removal. After the hinge pin (4) is removed, the clapper (10) can be removed.
5. To re-install clapper (10), and/or hinge pin (4):
 - a. Verify that the clapper rubber (12) is in good condition and that it is properly installed.
 - b. Position the clapper (10) with the elongated hinge holes aligned between the holes of the hinge bracket welded inside the cover assembly (2). The system (top) side of the clapper (10) must face the direction indicated by the flow arrow stamped inside the cover assembly (2).
 - c. Insert the hinge pin (4) through the holes at one end of the hinge assembly. Continue to push the hinge pin (4) through the holes at the remaining end of the hinge assembly.
 - d. Re-install the hinge pin retaining rings (5).
6. To re-install cover assembly (2):
 - a. Verify that cover gasket (15) is in position and in good condition. Slide the cover assembly (2) into the Swing Check Valve so that the clapper rubber (12) contacts the water seat (17).



TECHNICAL DATA

SWING CHECK VALVE MODEL F-2 VDS APPROVED

The Viking Corporation, 210 N Industrial Park Road, Hastings MI 49058

Telephone: 269-945-9501 Technical Services 877-384-5464 Fax: 269-945-4495 Email: techsvcs@vikingcorp.com

- b. Replace the cover screws (14). Use the appropriate wrench to cross-tighten all screws to the torque value shown in Table 2 for the valve used. DO NOT over-tighten.

7. AVAILABILITY

The Viking Swing Check Valve and accessories are available through a network of domestic, Canadian, and international distributors. See the Viking web site for a local distributor or contact The Viking Corporation.

8. GUARANTEES

For details of warranty, refer to Viking's current list price schedule or contact The Viking Corporation directly.

Size Valve	Inlet Type	Outlet Type	Friction Loss*	Shipping Weight	Part No.
3" (DN 80)	Flange	Flange	10 ft. (3,1 m)	20 lbs. (9 kg)	13017
3" (DN 80)	Groove	Groove	10 ft. (3,1 m)	20 lbs. (9 kg)	13018
4" (DN 100)	Flange	Flange	13 ft. (4,0 m)	47 lbs. (21 kg)	13020
4" (DN 100)	Groove	Groove	13 ft. (4,0 m)	27 lbs. (12 kg)	13021
6" (DN 150)	Flange	Flange	20 ft. (6,0 m)	75 lbs. (34 kg)	13024
6" (DN 150)	Groove	Groove	20 ft. (6,0 m)	51 lbs. (23 kg)	13023
6" (165 mm)	Groove	Groove	20 ft. (6,0 m)	51 lbs. (23 kg)	13025
8" (DN 200)	Flange	Flange	23 ft. (7,0 m)	135 lbs. (61 kg)	PN16 13029
8" (DN 200)	Flange	Flange	23 ft. (7,0 m)	135 lbs. (61 kg)	PN10 13028
8" (DN 200)	Groove	Groove	23 ft. (7,0 m)	106 lbs. (47 kg)	13027

*Expressed in equivalent length of Schedule 40 pipe based on Hazen & Williams formula: C = 120.

Valve Size	Screw Size	Torque Value
3" (DN 80)	3/8"-16 H.H.C.	19 ft-lb 2,63 kg-m
4" (DN 100)	3/8"-16 H.H.C.	19 ft-lb 2,63 kg-m
6" (DN 150)	1/2"-13 H.H.C.	45 ft-lb 6,23 kg-m
8" (DN 200)	5/8"-11 H.H.C.	93 ft-lb 12,9 kg-m



TECHNICAL DATA

SWING CHECK VALVE MODEL F-2 VDS APPROVED

The Viking Corporation, 210 N Industrial Park Road, Hastings MI 49058

Telephone: 269-945-9501 Technical Services 877-384-5464 Fax: 269-945-4495 Email: techsvcs@vikingcorp.com

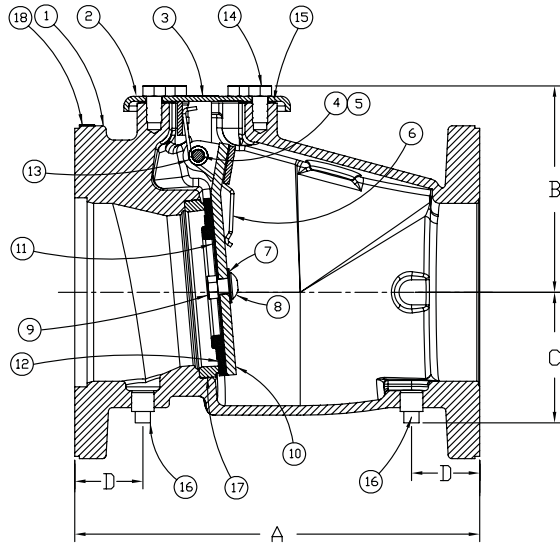

SIZE	A	B	C	D
3" (DN 80)	9-1/2" (241,3)	4-3/4" (120,7)	2-3/4" (69,9)	2-1/4" (57,2)
4" (DN 100)	10-5/8" (269,9)	5-3/16" (131,8)	3-3/8" (85,7)	2-1/4" (57,2)
6" (DN 150)	13-5/8" (346,1)	6-3/4" (171,5)	4-3/8" (111,1)	2-1/4" (57,2)
8" (DN 200)	17" (431,8)	8-3/4" (222,3)	5-3/8" (136,5)	2-7/8" (73,0)

Dimensions shown in parentheses are millimeter.
Dimensions are approximate.

* For availability of Flanged-Flanged or Grooved-Grooved options, refer to Table 1.

Figure 1

ITEM NO.	PART NUMBERS				DESCRIPTION	MATERIAL	NO. REQ'D			
	3" (DN80)	4" (DN100)	6" (DN150)	8" (DN200)			3"	4"	6"	8"
1	--	--	--	--	Body	Ductile Iron, 65-45-12	1	1	1	1
2	--	--	--	--	Cover Assembly	ASTM A715 Grade 50 HSLA Steel	1	1	1	1
3	--	--	--	--	Plate, Data	Aluminum Etched	1	1	1	1
4	05355A	04900A	04991A	05334A	Pin, Hinge	Stainless Steel UNS-S30400	1	1	1	1
5	05445A	05445A	04991A	05334A	Ring, Retaining	Stainless Steel UNS-S15700	2	2	2	2
6	06021B	05939B	05940B	05952B	Spring, Torsion	Stainless Steel UNS-30200	1	1	1	1
7	08158	08158	08143	08143	Washer, Sealing	Stainless Steel & EPDM	1	1	1	1
8	10194	10194	10308	10686	Screw	Stainless Steel UNS-S30400	1	1	1	1
9	08159	08159	08144	08144	Nut	Stainless Steel UNS-S30400	1	1	1	1
10	*	*	*	*	Clapper	HR Steel UNS-G10180	1	1	1	1
11	*	*	*	*	Retainer	Stainless Steel UNS-S30400	1	1	1	1
12	*	*	*	*	Rubber	EPDM ASTM D2000	1	1	1	1
13	07576	07576	07576	--	Bushing	Lubricomp 189 Rytan w/Celanese PPS Resin	2	2	2	--
14	01517A	01517A	--	--	Screw, H.H.C. 3/8-16 x 3/4 Lg.	Steel, SAE Grade 2, ASTM A307, Zinc Plated	4	6	--	--
	--	--	04993A	--	Screw, H.H.C. 1/2-13 x 7/8 Lg.	Steel, SAE Grade 5, ASTM A449	--	--	6	--
	--	--	--	01922A	Screw, H.H.C. 5/8-11 x 1-1/4 Lg.	Steel, SAE Grade 2, ASTM A307, Zinc Plated	--	--	--	6
15	05354B	04649B	04922B	05339C	Gasket, Cover	Black EPDM, ASTM D2000	1	1	1	1
16	--	--	--	--	Plug, Pipe 1/2" NPT	Steel	2	2	2	2
17	--	--	--	--	Seat	Brass, UNS-C84400	1	1	1	1
18	--	--	--	--	Plate, PN10/16 Flange Ident.	Aluminum	2	2	2	--
	--	--	--	--	Plate, PN10 Flange Ident.	Aluminum	--	--	--	2
	--	--	--	--	Plate, PN16 Flange Ident.	Aluminum	--	--	--	2

-- Indicates part is not available

* Indicates part is available in a Sub-Assembly only--see Sub-Assembly list.

SUB-ASSEMBLIES AVAILABLE

7-13	09916	09398	09421	09917	Clapper Assembly
7-9, 11,12,15	09912	09913	09914	09915	Replacement Rubber Kit