



TECHNICAL DATA

WATERFLOW INDICATOR

The Viking Corporation, 210 N Industrial Park Drive, Hastings MI 49058

Telephone: 269-945-9501 Technical Services 877-384-5464 Fax: 269-818-1680 Email: techsvcs@vikingcorp.com

1. DESCRIPTION

The Waterflow Indicator is a vane-type waterflow switch designed to detect a sustained flow of 10 gpm or more. It is intended for use on wet-pipe sprinkler systems only. The Model VSR has a built-in adjustable pneumatic retard device delays actuation of the electrical switches to reduce the possibility of false alarms caused by one or more transient flow surges. The unit includes two single-pole double-throw snap action switches used to operate local alarms, indicate signals to annunciator panels, trip municipal fire alarm boxes, start fire pumps, or any other function that can be initiated or controlled by the opening or closing of an electrical switch. The device may be installed on the main riser to give a system waterflow signal or on branch feed mains, cross mains, or branch lines to give a waterflow signal by zone or area.



2. LISTINGS AND APPROVALS

Model VSR-S

- UL Listed - Guide No. USQT.S309
- ULC Listed - Guide No. USQTC.S309
- CSFM Listed - 7770-0328:001
- NYC MEA Accepted - BSA-1033-83

Model VSR

- UL Listed - Guide No. USQT.S309
- ULC Listed - Guide No. USQTC.S309
- FM Approved - Waterflow Detectors, Vane Type
- CSFM Listed - 7770-0328:001
- LPCB Approved
- CE Certified - Standard EN-12259-5

Model VSR-10

- UL Listed - Guide No. USQT.S309
- ULC Listed - Guide No. USQTC.S309

3. TECHNICAL DATA

Manufactured by:

Potter Electric Signal Company, LLC
2081 Craig Drive
St. Louis, Missouri 63146

Specifications:

Water Working Pressure:

Model VSR-S rated for water working service pressure up to 300 psi (20.7 bar) for size 1", 1-1/4", 1-1/2" & 2" (25 mm, 32 mm, 38 mm & 50 mm)

Model VSR rated for water working service pressure up to 450 psi (31 bar) for sizes 2" (50 mm) to 8" (200 mm) - UL

Model VSR-10 rated for water working service pressure up to 300 psi (20.7 bar) for size 10" (250 mm)

Maximum Surge: 18 FPS (5.5 m/s)

Flow Sensitivity Range for Signal: 4-10 GPM (15-38 LPM) - UL

Contact Ratings:

Two single-pole double-throw switches with Form C contacts rated at 10 Amps @ 125/250 VAC, 2.0 Amps @ 0-30 VDC, 10m Amps min. @ 24VDC. Each switch can be wired for open or closed circuit operation. See Figure 8.

Conduit Entrances: Two knockouts provided for 1/2" conduit. Individual switch compartments suitable for dissimilar voltages.

Usage: Listed plastic, copper and schedule 40 iron pipe.

VSR-S - Fits pipe sizes 1" (25 mm), 1-1/4" (32 mm), 1-1/2" (38 mm) and 2" (50 mm) Note: 12 paddles are furnished with each unit, one for each pipe size of threaded and sweat TEE, one for 1" (25 mm) CPVC, one for 1" (25 mm) CPVC (Central), one for 1" threaded NIBCO CPVC, and one for 1-1/2" (38 mm) threaded (Japan).

Material Standards:

Body: Cast Aluminum

Base: Cast aluminum.

Enclosure: Die-cast, red enamel finish

Cover held in place with tamper-resistant screws

Viking Technical Data may be found on
The Viking Corporation's Web site at
<http://www.vikinggroupinc.com>.
The Web site may include a more recent
edition of this Technical Data Page.



TECHNICAL DATA

WATERFLOW INDICATOR

The Viking Corporation, 210 N Industrial Park Drive, Hastings MI 49058

Telephone: 269-945-9501 Technical Services 877-384-5464 Fax: 269-818-1680 Email: techsvcs@vikingcorp.com

Ordering Information:

See Table 1.

4. INSTALLATION

VSR-S Model

These devices may be mounted in horizontal or vertical pipe. On horizontal pipe they should be installed on the top side of the pipe where they will be accessible. The units should not be installed within 6" (15 cm) of a valve, drain or fitting that changes the direction of the waterflow. Select the proper paddle for the pipe size and type of TEE used; see Figure 1 for instructions on changing paddle. The unit has a 1" NPT bushing for threading into a non-corrosive TEE. See Figure 2 for proper TEE size, type and installation. Use no more than three wraps of Teflon tape.

Screw the device into the TEE fitting as shown in Figure 2. Care must be taken to properly orient the device for the direction of waterflow. The vane must not rub the inside of the TEE or bind in any way. The stem should move freely when operated by hand. The device can also be used in copper or plastic pipe installations with the proper adapters so that the specified TEE fitting may be installed on the pipe run.

VSR and VSR-10 Model

These devices may be mounted on horizontal or vertical pipe. On horizontal pipe they should be installed on the top side of the pipe where they will be accessible. The device should not be installed within 6" (15 cm) of a fitting which changes the direction of the waterflow or within 24" (60 cm) of a valve or drain. Drain the system and drill a hole in the pipe using a hole saw in a slow speed drill (see Figure 1). Clean the inside pipe of all growth or other material for a distance equal to the pipe diameter on either side of the hole. Roll the vane so that it may be inserted into the hole; do not bend or crease it. Insert the vane so that the arrow on the saddle points in the direction of the waterflow. Install the saddle strap and tighten nuts alternately to required torque (see Figure 4). The vane must not rub the inside of the pipe or bind in any way.

Place the system back in service and test the waterflow indicator using the system inspector's test valve. If necessary, adjust the pneumatic retard and/or equipment and perform quarterly inspection.

Adjustments

- A. The pneumatic retard is adjustable from 0 to approximately 90 seconds. To increase the time delay, turn the dial to the next higher letter. Normal setting is between 30 and 45 seconds. In no case should the time be set less than 20 seconds nor more than 90 seconds.
- B. The flow sensitivity is set at approximately 10 gpm. A small coil spring holds the vane in its normal position against the waterflow. The spring can be adjusted to increase or decrease sensitivity, if necessary, but it must not be over-tightened. Too much tension will decrease the sensitivity of the device. The pneumatic retard must be checked after adjusting the flow sensitivity. All testing and adjusting of the waterflow indicator must be done using the remote inspector's test valve.

5. OPERATION

The Waterflow Indicator detects a flow of water exceeding 10 gpm in the piping when the flexible vane is deflected. This motion activates the field-adjustable pneumatic retard device. The pneumatic retard device delays activation of the electrical switches to reduce the possibility of false alarms caused by a single or series of transient flow surges. The retard device instantly resets during a series of surges to prevent a cumulative effect. After a sustained flow, the two switches operate to open or close electrical contacts.

6. INSPECTIONS, TESTS AND MAINTENANCE

WARNING: Any system maintenance or testing that involves placing a control valve or detection system out of service may eliminate the fire protection of that system. Prior to proceeding, notify all authorities having jurisdiction. Consideration should be given to employment of a fire patrol in the affected area. Ascertain what alarms and equipment are connected to the waterflow indicator and take necessary precautions to protect connected equipment.

Testing

The frequency of inspection and testing for the Model VSR-S, VSR and VSR-10 and its associated protective monitoring system should be in accordance with applicable NFPA Codes and Standards and/or the authority having jurisdiction (manufacturer recommends quarterly or more frequently.) An inspector's test valve (usually located at the end of the most remote branch line) should always be used for test purposes. If there are no provisions for testing the operation of the flow detection device on the system, application of the VSR-S is not recommended or advisable. A minimum flow of 10 gpm (38 Lpm) is required to activate this device.

Maintenance

Inspect detectors monthly for leaks. If leaks are found, replace the detector. The VSR-S, VSR and VSR-10 waterflow switch should provide years of trouble-free service. The retard and switch assembly are easily field replaceable. There is no maintenance required, only periodic testing and inspection.

	<h1 style="margin: 0;">TECHNICAL DATA</h1>	<h2 style="margin: 0;">WATERFLOW INDICATOR</h2>
---	--	---

The Viking Corporation, 210 N Industrial Park Drive, Hastings MI 49058

Telephone: 269-945-9501 Technical Services 877-384-5464 Fax: 269-818-1680 Email: techsvcs@vikingcorp.com

Removal

- To prevent accidental water damage, all control valves should be shut tight and the system completely drained before waterflow detectors are removed or replaced.
- Turn off electrical power to the detector, then disconnect wiring.
- Use a wrench on the flats of the bushing. Turn the switch counterclockwise to disengage the pipe threads.
- Gently lift with your fingers, roll the vane so it will fit through the hole while continuing to lift the waterflow detector.
- Lift detector clear of pipe.

7. AVAILABILITY & SERVICE

Viking Waterflow Indicators are available through a network of domestic and international distributors. See the Viking web site or contact The Viking Corporation for closet distributor.

8. GUARANTEES

For details of warranty, refer to Viking's current list price schedule or contact Viking directly.

Nominal Pipe Size	Hole Size	Friction Loss	Part Number	Model
Inches	Inches	PSI		
1" (25 mm)	See Note 1 below	3	VSRF0100	VSR-S
1-1/4" (32 mm)	See Note 1 below	3	VSRF0100	VSR-S
1-1/2" (38 mm)	See Note 1 below	3	VSRF0100	VSR-S
2" (50 mm)	1-1/4" (32 mm)	3	VSRF0200	VSR-2
2-1/2" (63.5 mm)	1-1/4" (32 mm)	3	VSRF0250	VSR-2 1/2
3" (80 mm)	2" (50 mm)	3	VSRF0300	VSR-3
3-1/2" (88.9 mm)	2" (50 mm)	3	VSRF0350	VSR-3 1/2
4" (101.6 mm)	2" (50 mm)	3	VSRF0400	VSR-4
5" (127 mm)	2" (50 mm)	1	VSRF0500	VSR-5
6" (150 mm)	2" (50 mm)	1	VSRF0600	VSR-6
8" (200 mm)	2" (50 mm)	1	VSRF0800	VSR-8
10" (254 mm)	2" (50 mm)	1	VSRF1000	VSR-10

Notes:

¹ 1" through 1-1/2" is installed in a tee in the piping rather than a hole in the piping. The waterflow indicator has a 1" male NPT fitting that screws into a 1" tee. See Figure 3.

Table 1



TECHNICAL DATA

WATERFLOW INDICATOR

The Viking Corporation, 210 N Industrial Park Drive, Hastings MI 49058

Telephone: 269-945-9501 Technical Services 877-384-5464 Fax: 269-818-1680 Email: techsvcs@vikingcorp.com

VSR-S MODEL

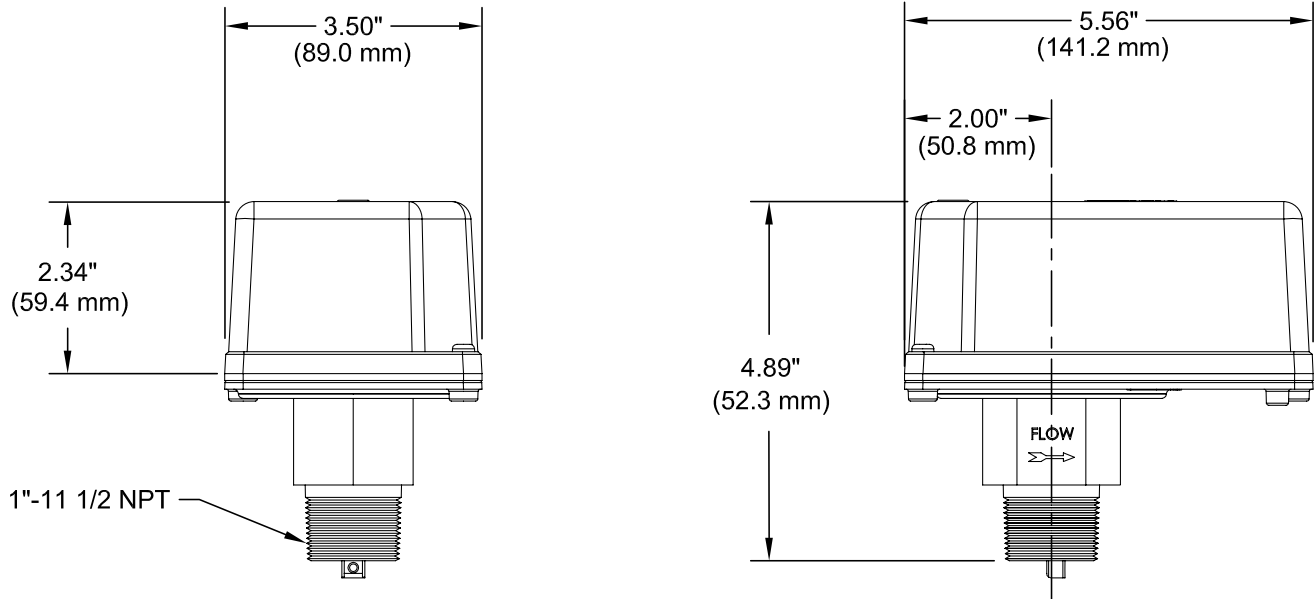

Figure 1

OPTIONAL COVER TAMPER SWITCH

DO NOT LEAVE COVER OFF FOR EXTENDED PERIOD OF TIME

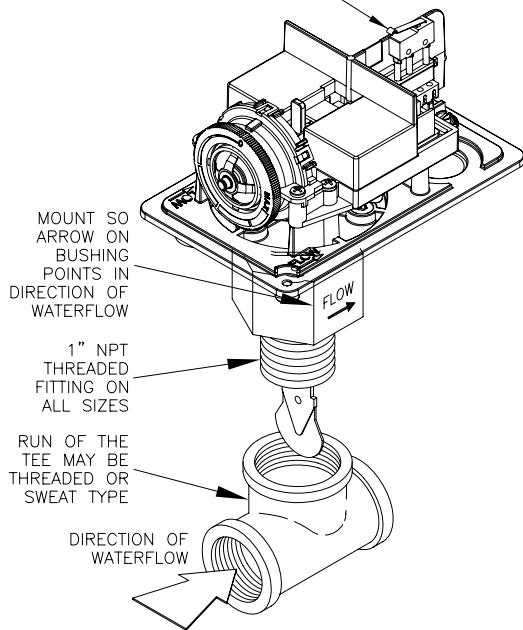
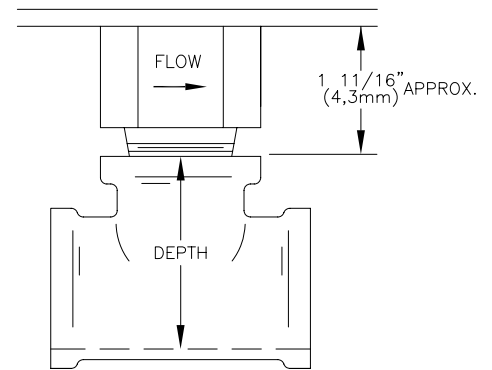

Figure 2



Screw the device into the TEE fitting as shown. Care must be taken to properly orient the device for the direction of the waterflow.

Important - The depth to the inside bottom of the TEE should have the following dimensions:

APPROXIMATE DEPTH REQUIREMENT			
TEE SIZE	THREADED	SWEAT	CPVC
1" x 1" x 1"	2 1/16"	1 3/4"	2 7/16"
1 1/4" x 1 1/4" x 1"	2 7/16"	2 7/16"	N/A
1 1/2" x 1 1/2" x 1"	2 11/16"	2 1/4"	N/A
2" x 2" x 1"	3 3/16"	2 3/4"	N/A

Figure 3



TECHNICAL DATA

WATERFLOW INDICATOR

The Viking Corporation, 210 N Industrial Park Drive, Hastings MI 49058

Telephone: 269-945-9501 Technical Services 877-384-5464 Fax: 269-948-4686 Email: techsvcs@vikingcorp.com

VSR MODEL

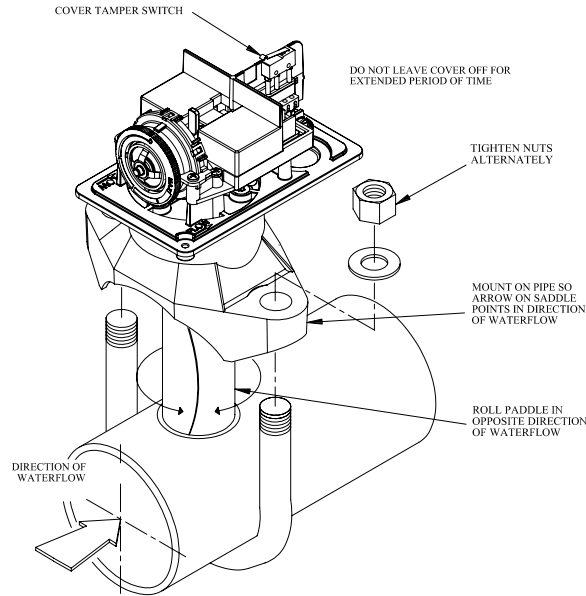

Model	Nominal Pipe Size		Nominal Pipe O.D.		Hole Size		U-Bolt Nuts Torque	
	inch	mm	inch	mm	inch	mm	ft-lb	n-m
VSR-2	2	DN50	2.375	60.3	1.25 + .125/- .062	33.0 ± 2.0	20	27
VSR-2 1/2	2 1/2		2.875	73				
VSR-2 1/2	2 1/2	DN65	3.000	76.1				
VSR-3	3	DN80	3.500	88.9				
VSR-3 1/2	3 1/2		4.000	101.6	2.00 ± .125	50.8 ± 2.0	20	27
VSR-4	4	DN100	4.500	114.3				
VSR-5	5		5.563	141.3				
VSR-6	6	DN150	6.625	168.3				
VSR-8	8	DN200	8.625	219.1				

Figure 4

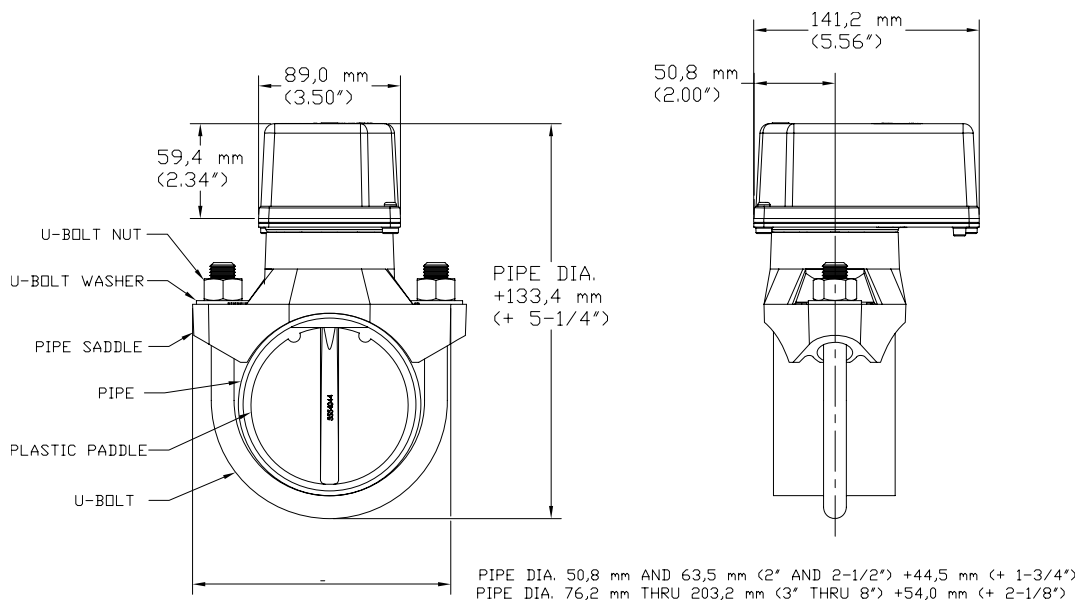

Figure 5



TECHNICAL DATA

WATERFLOW INDICATOR

The Viking Corporation, 210 N Industrial Park Drive, Hastings MI 49058

Telephone: 269-945-9501 Technical Services 877-384-5464 Fax: 269-818-1680 Email: techsvcs@vikingcorp.com

VSR-10 MODEL

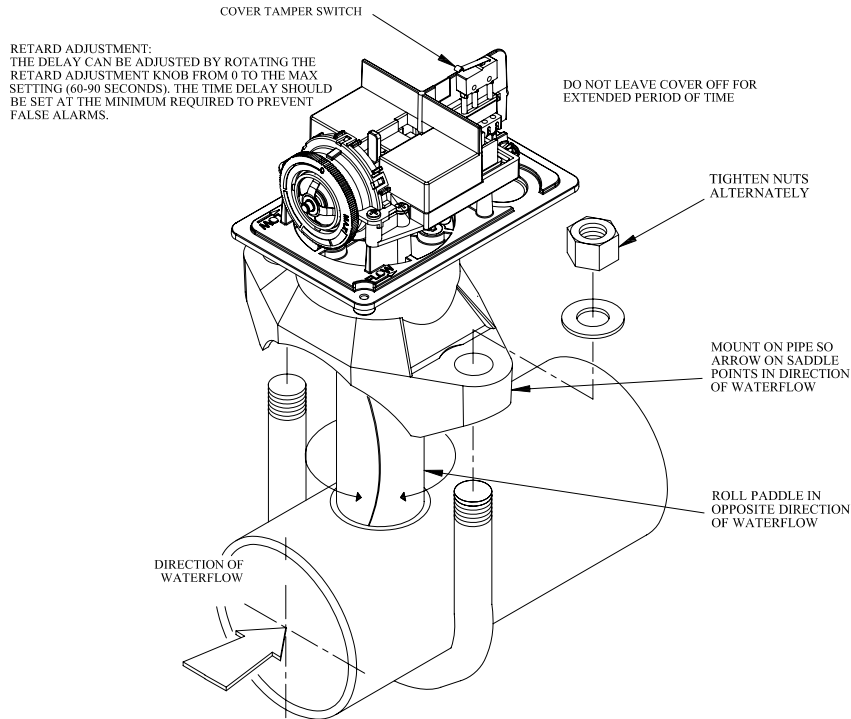

INSTALLATION REQUIREMENTS								
Model	Nominal Pipe Size		Nominal Pipe O.D.		Hole Size		U-Bolt Nuts Torque	
	inch	mm	inch	mm	inch	mm	ft-lb	n-m
VSR-10	10	DN250	10.750	273.0	2.00 ± .125	50.8 ± 2.0	20	27

Figure 6

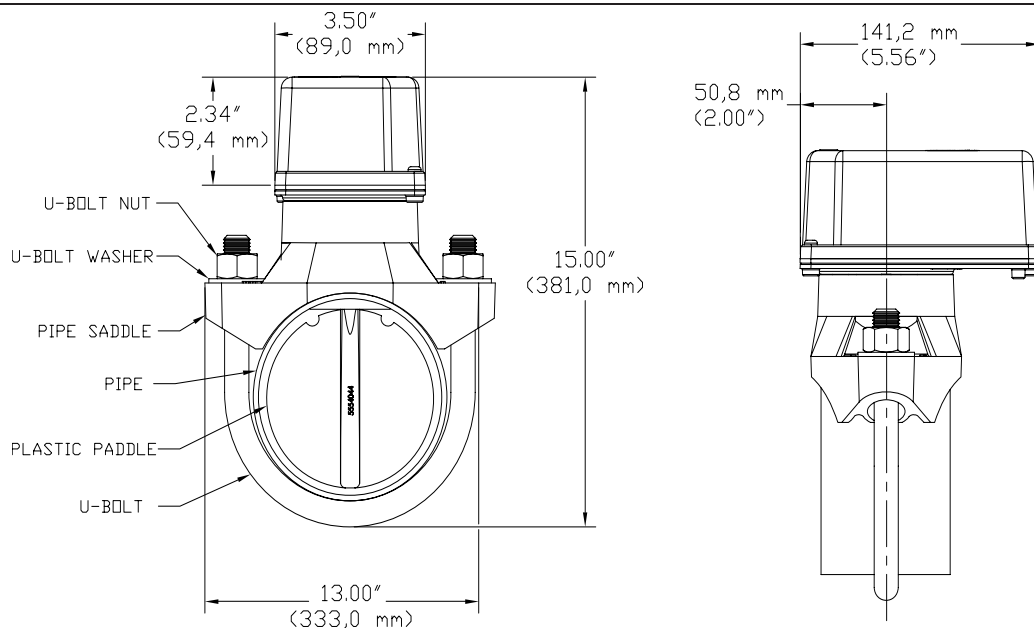

Figure 7



TECHNICAL DATA

WATERFLOW INDICATOR

The Viking Corporation, 210 N Industrial Park Drive, Hastings MI 49058

Telephone: 269-945-9501 Technical Services 877-384-5464 Fax: 269-818-1680 Email: techsvcs@vikingcorp.com

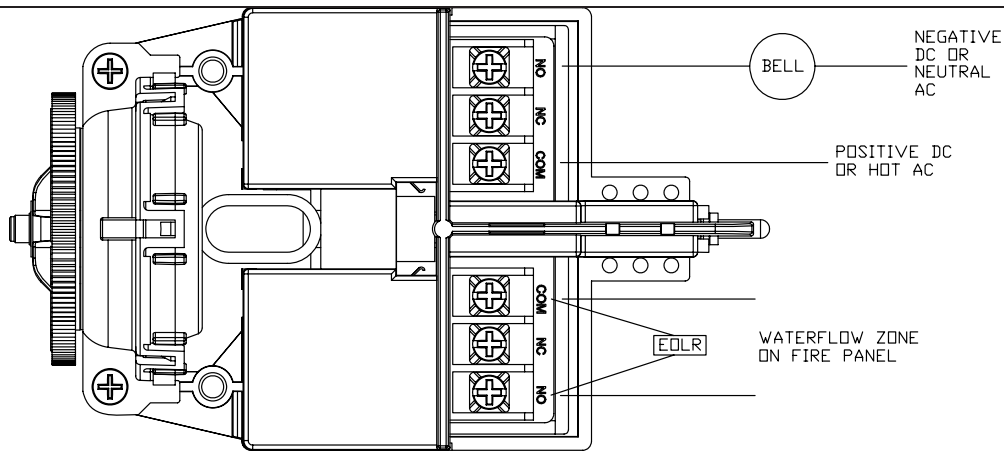

Figure 8: Typical Electrical Connections

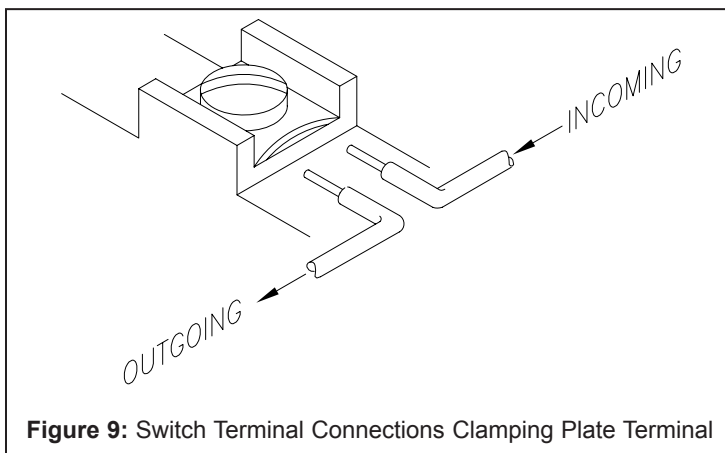

Figure 9: Switch Terminal Connections Clamping Plate Terminal

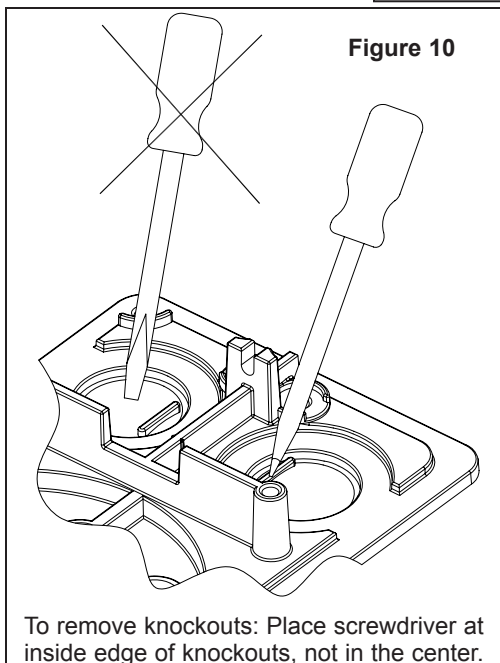

Figure 10

To remove knockouts: Place screwdriver at inside edge of knockouts, not in the center.

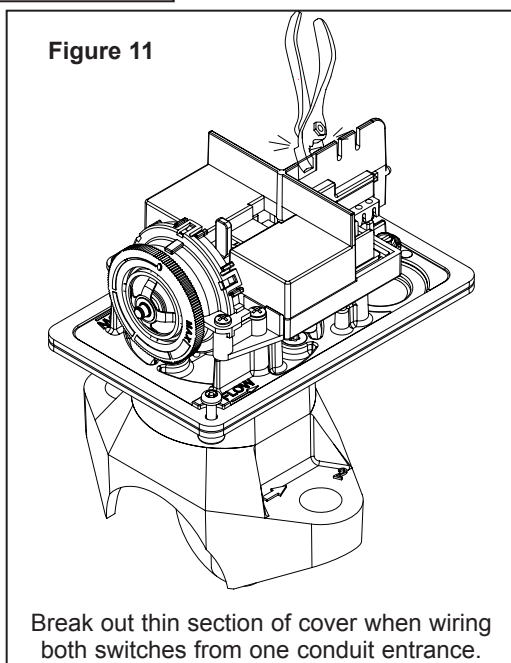

Figure 11

Break out thin section of cover when wiring both switches from one conduit entrance.

**THIS PAGE INTENTIONALLY
LEFT BLANK**