	<h1 style="margin: 0;">TECHNICAL DATA</h1>	<p>SPRING LOADED IN-LINE CHECK VALVE</p> <p>1-1/2" & 2" MODELS K-1 & L-1</p>
---	--	--

The Viking Corporation, 210 N Industrial Park Drive, Hastings MI 49058

Telephone: 269-945-9501 Technical Services 877-384-5464 Fax: 269-945-4495 Email: techsvcs@vikingcorp.com

1. DESCRIPTION

The Viking Spring Loaded In-Line Check Valve is a general purpose rubber-faced check valve approved for use in fire-service systems.

The Spring Loaded In-Line Check Valve is manufactured with a brass body, brass seat, and a rubber-faced clapper assembly.

The valve may be installed vertically or horizontally. For availability of threaded and grooved-grooved options, refer to Table 1. A tapped opening (with plug) is provided on the outlet chamber of the valve for system drain. The 1-1/2" and 2" check valves should be installed on the outlet riser of the 1-1/2" and 2" deluge valve when installing a listed and approved preaction system. Refer to preaction data pages for current riser schematic.



FEATURES

1. Low friction loss.
2. Rated to 250 psi (17.2 bar) water working pressure.
3. Can be installed vertically or horizontally.
4. 3/4" NPT drain connection above the clapper.
5. 1 PSI cracking pressure

2. LISTINGS AND APPROVALS

Refer to Table 1

3. TECHNICAL DATA

Specifications

Pressure Rating - 250 psi (17.2 bar) water working pressure
 Factory tested - Hydrostatically to 500 psi (34.5 bar).
 Standard threaded connections - NPT
 Standard grooved connections - ANSI/AWWA C606-87
 Tapped Bosses - One 3/4" (19 mm) NPT:

Material Standards

Refer to Figure 1

Ordering Information

Refer to Table 1
 Manufactured 2002 -

Viking Technical Data may be found on The Viking Corporation's Web site at <http://www.vikingcorp.com>. The Web site may include a more recent edition of this Technical Data Page.

For piping with grooved connections, the grooved-inlet/grooved-outlet style Spring Loaded In-Line Check Valve may be installed with listed grooved couplings of the appropriate pressure rating.

4. INSTALLATION

The Spring Loaded In-Line Check Valve must be installed in an area not subject to physical damage. When corrosive atmospheres and/or contaminated water supplies are present, it is the owner's responsibility to verify compatibility with the Check Valve and associated equipment.

Prior to installing the valve, thoroughly flush the water supply piping to verify that no foreign matter is present.

The Check Valve may be installed in the vertical or horizontal position in line with the directional flow arrow.

Table 1								
Model	Size Valve	Connection Type	Cv Factor	Friction Loss*	Shipping Weight	Part No.	Approvals	
							UL ¹	FM ²
K-1	1-1/2"	Threaded	57	7	4 lbs	10659	Yes	No
K-1	2"	Threaded	105	8	5.5 lbs	10667	Yes	No
L-1	1-1/2"	Groove	68	5	4.5 lbs	11054	Yes	Yes
L-1	2"	Groove	102	8	6 lbs	11059	Yes	Yes

*Expressed in equivalent length of schedule 40 pipe based on Hazen & Williams formula: C=120

¹ UL Guide No. - HMER

² FM Category - Single Check Valves



TECHNICAL DATA

**SPRING LOADED IN-LINE
CHECK VALVE
1-1/2" & 2" MODELS K-1 & L-1**

The Viking Corporation, 210 N Industrial Park Drive, Hastings MI 49058

Telephone: 269-945-9501 Technical Services 877-384-5464 Fax: 269-945-4495 Email: techsvcs@vikingcorp.com

Hydrostatic Test:

The Check Valve is manufactured and listed for use at a maximum water working pressure of 250 psi (17.2 bar). The valve is factory tested at 500 psi (34.5 bar). Check Valves may be hydrostatically tested at 300 psi (20.7 bar) and/or 50 psi (3.4 bar) above the normal water working pressure, for limited periods of time (two hours), for the purpose of acceptance by the Authority Having Jurisdiction. If air testing is required, do not exceed 60 psi (4.1 bar) air pressure.

5. OPERATION (Refer to Figure 1 or Figure 2)

Flow through the Viking Spring Loaded In-Line Check Valve lifts the rubber-gasketed clapper (4 and 5) off the seat (7) to enter the sprinkler piping. When flow through the valve stops, the spring loaded clapper (4) closes quickly. The rubber gasket (5) forms a tight seal against the brass water seat (7), trapping pressure above the clapper and preventing reverse flow from sprinkler piping.

6. INSPECTIONS, TESTS AND MAINTENANCE

NOTICE: THE OWNER IS RESPONSIBLE FOR MAINTAINING THE FIRE-PROTECTION SYSTEM AND DEVICES IN PROPER OPERATING CONDITION.

The Viking Spring Loaded In-Line Check Valve must be kept free of foreign matter, freezing conditions (when used on wet systems), corrosive atmospheres, contaminated water supplies, and any condition that could impair its operation or damage the device.

It is imperative that the system be inspected and tested on a regular basis. The frequency of the inspections may vary due to contaminated water supplies, corrosive water supplies, and corrosive atmospheres. For minimum maintenance and inspection requirements, refer to NFPA 25. In addition, the Authority Having Jurisdiction may have additional maintenance, testing, and inspection requirements which must be followed.

WARNING: ANY SYSTEM MAINTENANCE WHICH INVOLVES PLACING A CONTROL VALVE OR DETECTION SYSTEM OUT OF SERVICE MAY ELIMINATE THE FIRE-PROTECTION CAPABILITIES OF THAT SYSTEM. PRIOR TO PROCEEDING, NOTIFY ALL THE AUTHORITY HAVING JURISDICTION. CONSIDERATION SHOULD BE GIVEN TO EMPLOYMENT OF A FIRE PATROL IN THE AFFECTED AREAS.

A. Five-Year Internal Inspection (Refer to Figure 1 or 2)

Internal inspection of Check Valves is recommended every five years unless inspections and tests indicate more frequent inspections are required.

1. Notify the Authority Having Jurisdiction, remote station alarm monitors, and those in the area affected that the system will be taken out of service. Consideration should be given to employment of a fire patrol in the affected areas.
2. Close the water supply Main Control Valve, placing the system out of service.
3. Open the main drain. If necessary, open the system test valve to vent and completely drain the system.
4. Remove necessary fittings and/or piping to allow visual inspection.
5. Inspect the water seat (7). Wipe away all contaminants, dirt, and mineral deposits. Do not use solvents or abrasives.
6. Inspect the clapper for debris. Test the clapper (4) for freedom of movement.

CAUTION: NEVER APPLY ANY LUBRICANT TO SEATS, GASKETS, OR ANY INTERNAL OPERATING PARTS OF THE VALVE. PETROLEUM-BASED GREASE OR OIL WILL DAMAGE RUBBER COMPONENTS AND MAY PREVENT PROPER OPERATION.

B. Valve Maintenance (Refer to Figure 1 or 2)

1. Perform steps 1 through 5 of paragraph 10-A FIVE-YEAR INTERNAL INSPECTION.
2. To remove clapper rubber (5):
 - a. Use proper wrench and disassemble valve from system piping.
 - b. Inspect the clapper and rubber from inlet end. If the clapper rubber shows signs of wear, such as cracking, cuts, or excessively deep grooves where the rubber contacts the water seat, replace the valve.

7. AVAILABILITY

The Viking Check Valve and Accessories are available through a network of domestic and international distributors. See the Viking Corp. Web site for closest distributor or contact The Viking Corporation.

8. GUARANTEES

For details of warranty, refer to Viking's current list price schedule or contact Viking directly.



TECHNICAL DATA

SPRING LOADED IN-LINE CHECK VALVE 1-1/2" & 2" MODELS K-1 & L-1

The Viking Corporation, 210 N Industrial Park Drive, Hastings MI 49058

Telephone: 269-945-9501 Technical Services 877-384-5464 Fax: 269-945-4495 Email: techsvcs@vikingcorp.com

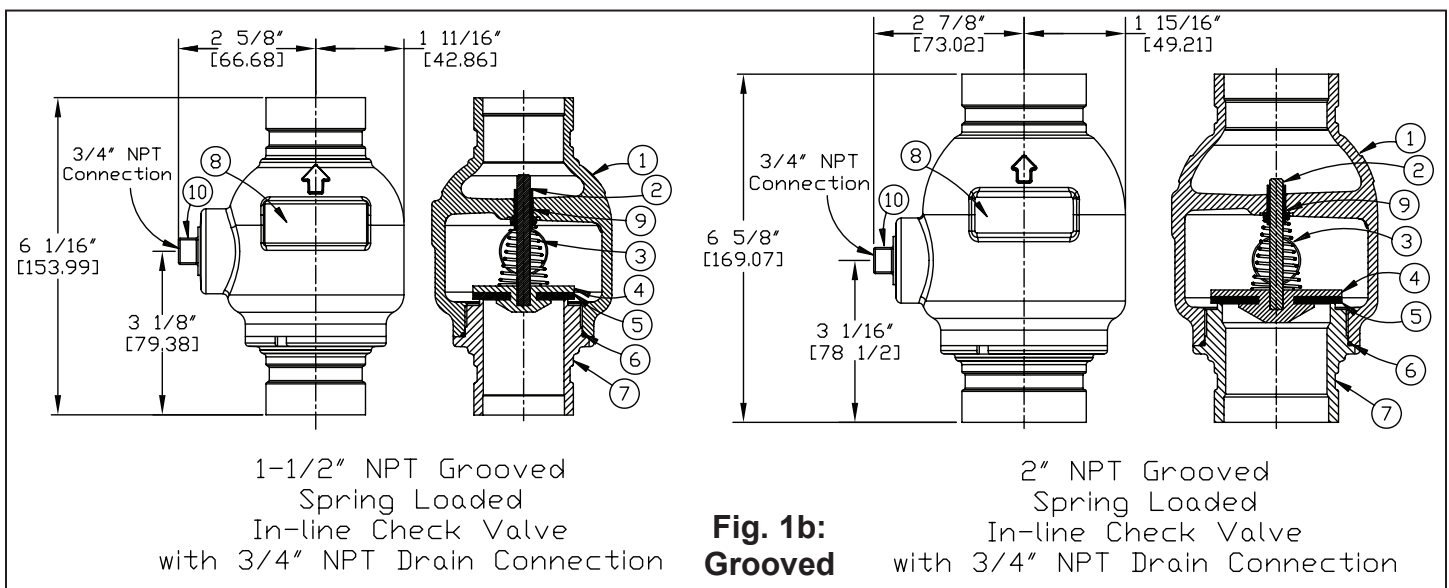
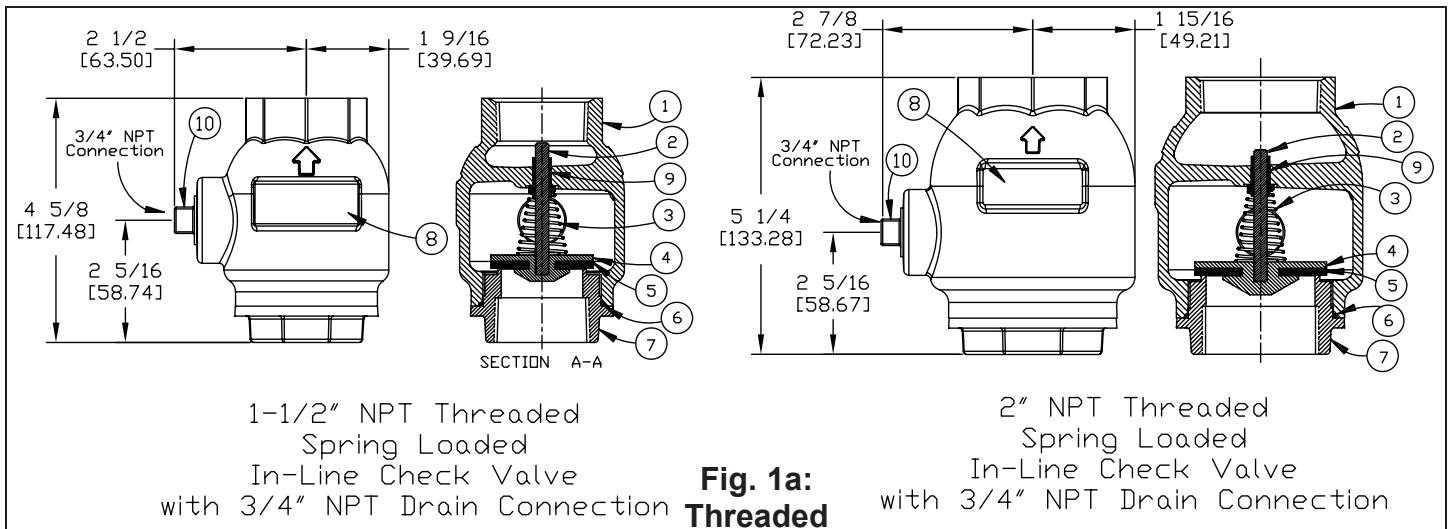

Item No.	Description	Material	No. Req'd.
1	Body, Threaded or Grooved	Brass, ASTM C-83600	1
2	Guide Pin	UNS-S30300 Stainless Steel	1
3	Spring	302 Stainless Steel	1
4	Clapper, (2" valve)	UNS-C46400 Naval Brass	1
	Clapper, (1-1/2" valve)	UNS-C83600 Naval Brass	1
5	Seat Rubber	EPDM, ASTM D2000	1
6	O-ring	Buna-N	1
7	Seat	Brass, ASTM C-83600	1
8	Data Plate	Aluminum Etched	1
9	Bushing, Guide Rod	Stainless Steel, Type 17-4	1
10	3/4" Pipe Plug	Brass	1

No replacement parts available. Replace complete valve.



TECHNICAL DATA

**SPRING LOADED IN-LINE
CHECK VALVE
1-1/2" & 2" MODELS K-1 & L-1**

The Viking Corporation, 210 N Industrial Park Drive, Hastings MI 49058

Telephone: 269-945-9501 Technical Services 877-384-5464 Fax: 269-945-4495 Email: techsvcs@vikingcorp.com

Note: Water and Air Gauge Provided.
Wet Systems: Use Water Gauge
Preaction Systems: Use Air Gauge

REMOVE PIPE PLUG
AT ASSEMBLY

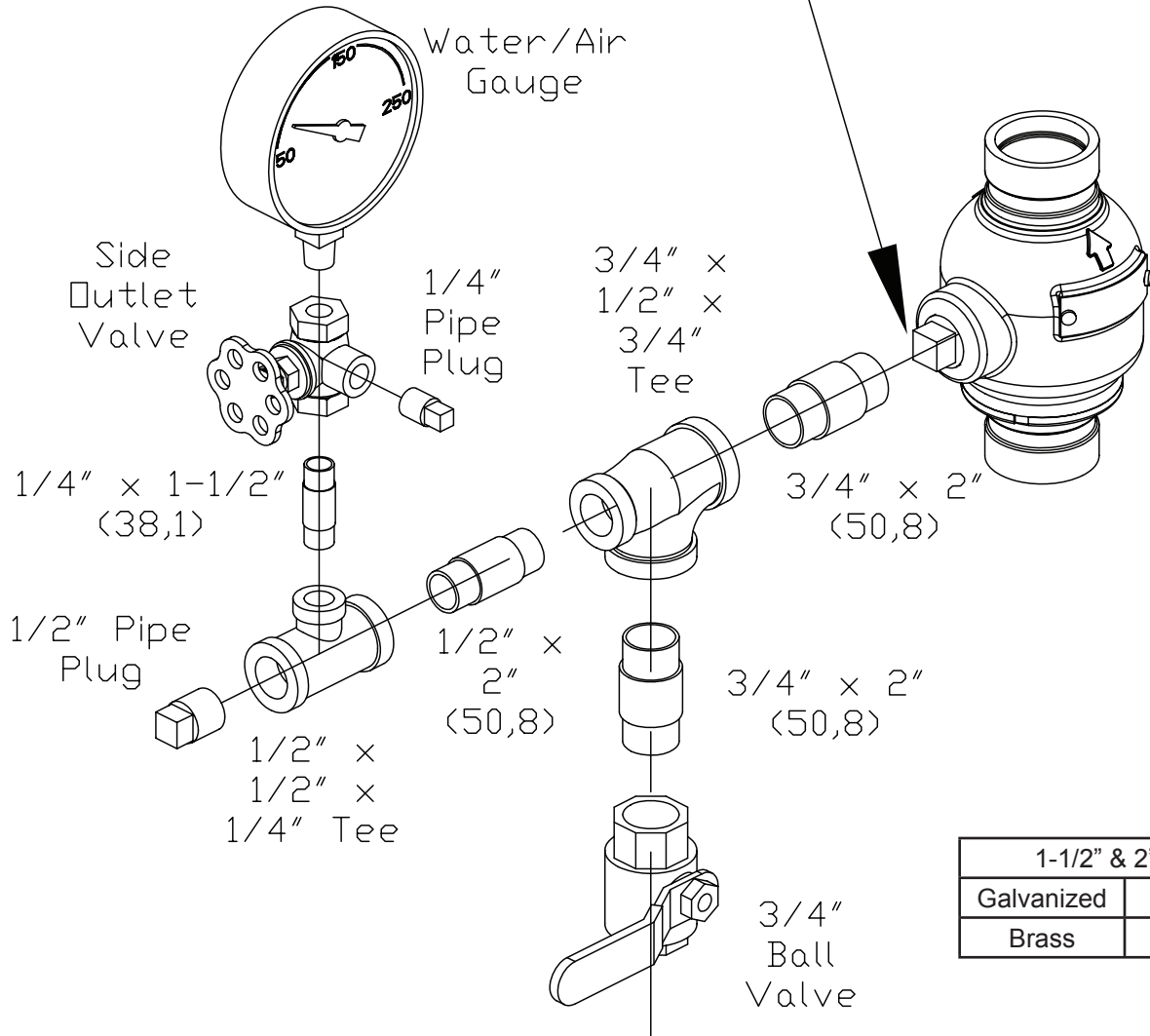

1-1/2" & 2" Trim	
Galvanized	12960
Brass	12960-1

Figure 2: Model L-1 & K-1 Check Valve Trim Chart