

	TECHNICAL DATA	SWING CHECK VALVE MODEL D-1 & G-1
---	----------------	--------------------------------------

**The Viking Corporation, 210 N Industrial Park Drive, Hastings MI 49058**

**Telephone: 269-945-9501 Technical Services: 877-384-5464 Fax: 269-818-1680 Email: techsvcs@vikingcorp.com**

**1. DESCRIPTION**

The Viking Swing Check Valve is a general purpose rubber-faced check valve approved for use in fire protection systems. The Swing Check Valve is manufactured with a ductile iron body, brass seat, and a rubber-faced clapper assembly, hinged to a removable access cover for easy inspection and maintenance.

The valve may be installed vertically or horizontally with access cover facing up. For availability of flanged-flanged and grooved-grooved options, refer to Table 1. Tapped openings (with plugs) and gauge connections are provided on both the inlet and outlet chambers of the valve.

**FEATURES**

- A. Ductile iron body for less weight and extra strength.
- B. Rated to 300 psi (20.7 bar) water working pressure.
- C. Rubber-faced clapper hinged to access cover for quick removal and easy servicing. All moving parts can be serviced without removing the valve from the installed position.
- D. With the cover/clapper assembly removed, the clapper rubber replacement requires removal of only one screw.
- E. Can be installed vertically or horizontally with access cover facing up.



**2. LISTINGS AND APPROVALS**

**cULus Listed:** Guide No. HMER  
**FM Approved:** Single Check Valves  
**NYC Department of Buildings:** MEA 89-92-E, Vol. XI

**3. TECHNICAL DATA**

**Specifications:**

Rated to 300 psi (20.7 bar) water working pressure.  
 Factory tested hydrostatically to 600 psi (41.4 bar).  
 Standard Flanged Connections: ANSI B16.42 Class 150 (mates with ANSI Class 125 and Class 150 flanges).  
 Standard Grooved Connections: ANSI/AWWA C606  
 Tapped Bosses: 2-1/2" (DN65), 3" (DN80) and 4" (DN100): Two 1/2" (15 mm) NPT  
 6" (DN150) and 8" (DN200): Two 3/4" (20 mm) NPT

Viking Technical Data may be found on The Viking Corporation's Web site at <http://www.vikinggroupinc.com>. The Web site may include a more recent edition of this Technical Data Page.

**Material Standards:** Refer to Figure 1.

**Ordering Information:** Refer to Table 1 for part numbers and shipping weight.

<b>Table 1</b>					
<b>Size Valve Nominal</b>	<b>Inlet Type</b>	<b>Outlet Type</b>	<b>Friction Loss*</b>	<b>Shipping Weight</b>	<b>Part No.</b>
2-1/2" (DN65)	Groove	Groove	6 ft.(1.8 m)	16 lbs. (7 kg)	05497C
3" (DN80)	Goove	Groove	10 ft. (3.1 m)	20 lbs. (9 kg)	08536
4" (DN100)	Flange	Flange	13 ft. (4.0 m)	47 lbs. (21 kg)	08538
4" (DN100)	Groove	Groove	13 ft. (4.0 m)	27 lbs. (12 kg)	08539
6" (DN150)	Flange	Flange	20 ft. (6.0 m)	75 lbs. (34 kg)	08542
6" (DN150)	Groove	Groove	20 ft. (6.0 m)	51 lbs. (23 kg)	08543
8" (DN200)	Flange	Flange	23 ft. (7.0 m)	135 lbs. (61 kg)	08546
8" (DN200)	Groove	Groove	23 ft. (7.0 m)	106 lbs. (48 kg)	08547

\*Expressed in equivalent length of Schedule 40 pipe based on Hazen & Williams formula: C = 120.

Systems with water working pressures above 175 psi (12 bar) may require extra-heavy pattern fittings. Viking Swing Check Valve flanges are Ductile Iron ANSI B16.42, Class 150, with a maximum water working pressure of 300 psi (20.7 bar). ANSI B16.42, Class 150 flanges are NOT compatible with ANSI Class 250 or Class 300 flanges. To mate the Viking Swing Check Valve with ANSI Class 250 or Class 300 flanges, use the grooved-inlet/grooved-outlet style installed with listed grooved/ flanged adapters of the appropriate pressure rating. For piping with grooved connections, the grooved-inlet/grooved-outlet style Swing Check Valve may be installed with listed grooved couplings of the appropriate pressure rating.



The Viking Corporation, 210 N Industrial Park Drive, Hastings MI 49058

Telephone: 269-945-9501 Technical Services: 877-384-5464 Fax: 269-818-1680 Email: techsvcs@vikingcorp.com

#### 4. INSTALLATION

The Swing Check Valve must be installed in an area not subject to physical damage. When corrosive atmospheres and/or contaminated water supplies are present, it is the owner's responsibility to verify compatibility with the Swing Check Valve and associated equipment. Prior to installing the valve, thoroughly flush the water supply piping to verify that no foreign matter is present. The Swing Check Valve may be installed in the vertical position with direction of flow up, or in the horizontal position with the access cover up.

Systems with water working pressures above 175 psi (12 bar) may require extra-heavy pattern fittings. Viking Swing Check Valve flanges are Ductile Iron ANSI B16.42, Class 150, with a maximum water working pressure of 300 psi (20.7 bar). ANSI B16.42, Class 150 flanges are not compatible with ANSI Class 250 or Class 300 flanges. To mate the Viking Swing Check Valve with ANSI Class 250 or Class 300 flanges, use the grooved-inlet/grooved-outlet style installed with listed grooved/flanged adapters of the appropriate pressure rating. For piping with grooved connections, the grooved-inlet/grooved-outlet style Swing Check Valve may be installed with listed grooved couplings of the appropriate pressure rating.

#### 5. OPERATION (Refer to Figure 1)

Flow through the Viking Swing Check Valve lifts the rubber-gasketed clapper (8, and 9) off the seat (12) to enter the sprinkler piping. When flow through the valve stops, the clapper (8) closes quickly. The rubber gasket (9) forms a tight seal against the brass water seat (12), trapping pressure above the clapper and preventing reverse flow from sprinkler piping.

##### Hydrostatic Test:

The Swing Check Valve is manufactured and listed for use at a maximum water working pressure of 300 psi (20.7 bar). The valve is factory tested at 600 psi (41.4 bar). Check Valves may be hydrostatically tested (in accordance with NFPA 13) at 350 psi (24.1 bar) and/or 50 psi (3.4 bar) above the normal water working pressure for limited periods of time (two hours) for the purpose of acceptance by the Authority Having Jurisdiction. If air testing is required, do not exceed 40 psi (2.8 bar) air pressure.

#### 6. INSPECTIONS, TESTS AND MAINTENANCE

**NOTICE: The owner is responsible for maintaining the fire-protection system and devices in proper operating condition.**

The Viking Swing Check Valve must be kept free of foreign matter, freezing conditions (when used on wet systems), corrosive atmospheres, contaminated water supplies, and any condition that could impair its operation or damage the device.

It is imperative that the system be inspected and tested on a regular basis. The frequency of the inspections may vary due to contaminated water supplies, corrosive water supplies, and corrosive atmospheres. For minimum maintenance and inspection requirements, refer to NFPA 25. In addition, the Authority Having Jurisdiction may have additional maintenance, testing, and inspection requirements that must be followed.

**WARNING: Any system maintenance which involves placing a control valve or detection system out of service may eliminate the fire-protection capabilities of that system. Prior to proceeding, notify all the Authority Having Jurisdiction. Consideration should be given to employment of a fire patrol in the affected areas.**

##### 6-A. Five-Year Internal Inspection

Internal inspection of Swing Check Valves is recommended every five years unless inspections and tests indicate more frequent inspections are required.

(Refer to Figure 1)

1. Notify the Authority Having Jurisdiction, remote station alarm monitors, and those in the area affected that the system will be taken out of service. Consideration should be given to employment of a fire patrol in the affected areas.
2. Close the water supply main control valve, placing the system out of service.
3. Open the main drain. If necessary, open the system test valve to vent and completely drain the system.
4. Use the appropriate wrench to loosen and remove the cover screws (14), and remove the cover/clapper assembly (2-11).
5. Inspect the water seat (12). Wipe away all contaminants, dirt, and mineral deposits. DO NOT use solvents or abrasives.
6. Inspect the cover/clapper assembly (2-11) and the cover gasket (13). Test the hinged clapper (8) for freedom of movement. Renew or replace damaged or worn parts as required.

**CAUTION: Never apply any lubricant to seats, gaskets, or any internal operating parts of the valve. Petroleum-based grease or oil will damage rubber components and may prevent proper operation.**

7. When Internal inspection of the Check Valve is complete, perform step 6 of paragraph 11. VALVE MAINTENANCE to re-install the cover/clapper assembly (2-11).



The Viking Corporation, 210 N Industrial Park Drive, Hastings MI 49058

Telephone: 269-945-9501 Technical Services: 877-384-5464 Fax: 269-818-1680 Email: techsvcs@vikingcorp.com

**6-B. Valve Maintenance**

(Refer to Figure 1)

1. Perform steps 1 through 5 of paragraph 6.A - FIVE-YEAR INTERNAL INSPECTION.
2. To remove clapper rubber (9):
  - a. Use the appropriate wrenches to loosen and remove the button-head socket screw (11), hex nut (6), sealing washer (7), and rubber retainer (10).
  - b. Remove the clapper rubber (9) for inspection. If the clapper rubber shows signs of wear, such as cracking, cuts, or excessively deep grooves where the rubber contacts the water seat, replace the rubber.
3. To re-install clapper rubber (9):
  - a. Place the clapper rubber (9) over the center hub of the rubber retainer (10).
  - b. Position the retainer (10) (with rubber in place) against the clapper (8) as shown in Figure 1.
  - c. Replace and tighten the button-head socket screw (11), sealing washer (7), and hex nut (6). The sealing washer (7) and hex nut (6) must be located on the top side of the clapper as shown in Figure 1. Do not over-tighten.
4. To remove clapper (8), and/or hinge pin (4):
  - a. Remove the hinge pin retaining rings (5) to free the hinge pin (4) for removal. After the hinge pin (4) is removed, the clapper (8) can be removed.
5. To re-install clapper (8), and/or hinge pin (4):
  - a. Verify that the clapper rubber (9) is in good condition and that it is properly installed.
  - b. Position the clapper (8) with the elongated hinge holes aligned between the holes of the hinge bracket welded inside the cover (2). The system (top) side of the clapper (8) must face the direction indicated by the flow arrow stamped inside the cover (2).
  - c. Insert the hinge pin (4) through the holes at one end of the hinge assembly. Continue to push the hinge pin (4) through the holes at the remaining end of the hinge assembly.
  - d. Re-install the hinge pin retaining rings (5).
6. To re-install cover/clapper assembly (2-11):
  - a. Verify that cover gasket (13) is in position and in good condition.
  - b. Slide the cover/clapper assembly (2-11) into the Swing Check Valve so that the clapper rubber (9) contacts the water seat (12).
  - c. Replace the cover screws (14). Use the appropriate wrench to cross-tighten all screws to the torque value shown in Table 2 for the valve used. DO NOT over-tighten.

**7. AVAILABILITY**

The Viking Swing Check Valve is available through a network of domestic and international distributors. See the Viking Corp. Web site for closest distributor or contact The Viking Corporation.

**8. GUARANTEES**

For details of warranty, refer to Viking's current list price schedule or contact The Viking Corporation directly.

Valve Size	Screw Size	Torque Values
2-1/2" (DN65)	3/8"-16 HHC	19 ft-lbs 2.63 kg-m
3" (DN80)	3/8"-16 HHC	19 ft-lbs 2.63 kg-m
4" (DN100)	3/8"-16 HHC	19 ft-lbs 2.63 kg-m
6" (DN150)	1/2"-13 HHC	45 ft-lbs 6.23 kg-m
8" (DN200)	5/8"-11 HHC	93 ft-lbs 12.9 kg-m



# TECHNICAL DATA

## SWING CHECK VALVE MODEL D-1 & G-1

The Viking Corporation, 210 N Industrial Park Drive, Hastings MI 49058

Telephone: 269-945-9501 Technical Services: 877-384-5464 Fax: 269-818-1680 Email: techsvcs@vikingcorp.com

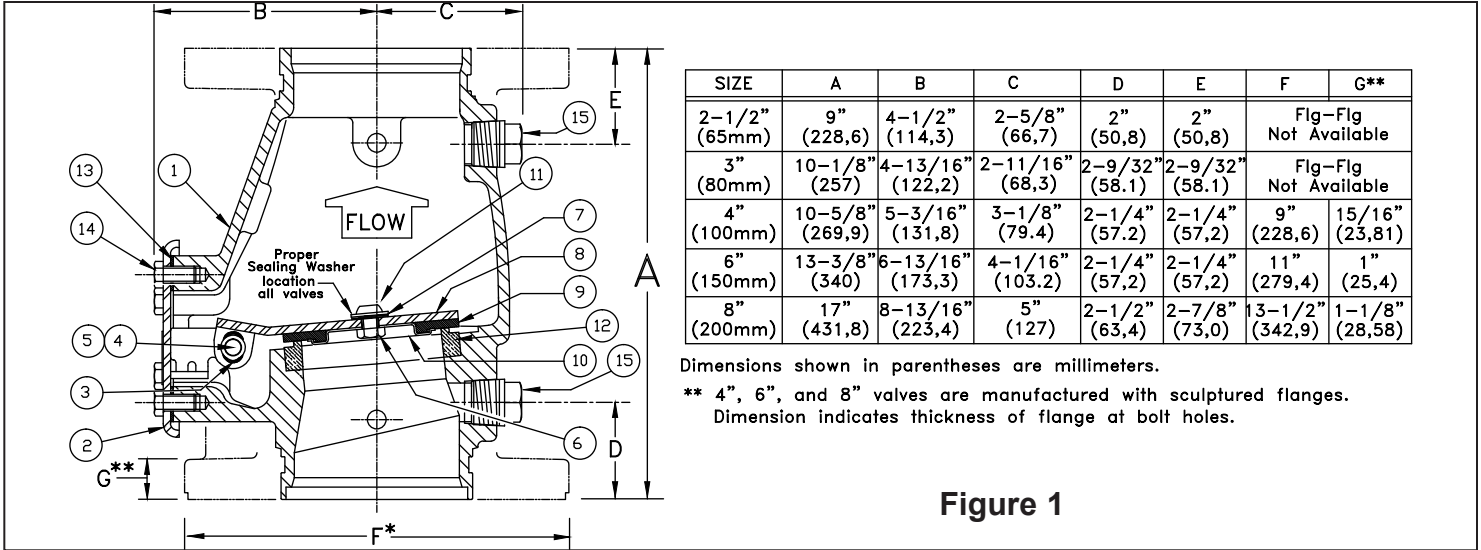

Figure 1

ITEM NO.	PART NUMBER					DESCRIPTION	MATERIAL	NO. REQ'D				
	D-1	G-1	G-1	G-1	G-1							
	2-1/2" (DN65)	3" (DN80)	4" (DN100)	6" (DN150)	8" (DN200)			2-1/2"	3"	4"	6"	8"
1	--	--	--	--	--	Body	Ductile Iron, ASTM A536 (65-45-12)	1	1	1	1	1
2	--	--	--	--	--	Cover Assembly, 300 PSI WWP	E-Coated HSLA Steel, A715 and Stainless Steel, UNS-S30400	1	1	1	1	1
3	07576	07576	07576	07576	None	Bushing	Lubricomp 189 Ryton	2	2	2	2	0
4	05355A	05355A	04900A	04991A	05334A	Clapper Hinge Pin	Stainless Steel, UNS-S30400	1	1	1	1	1
5	05445A	05445A	05445A	05445A	05369A	Hinge Pin Retaining Ring	Stainless Steel, UNS-S15700	2	2	2	2	2
6	01755A					Clapper Hex Jam Nut #10-24 UNC	Stainless Steel, UNS-S30400	1	0	0	0	0
		08159	08159			Clapper Hex Jam Nut 3/8"-24 UNF	Stainless Steel, UNS-S30400	0	1	1	0	0
				08144	08144	Clapper Hex Jam Nut 1/2"-20 UNC	Stainless Steel, UNS-S30400	0	0	0	1	1
7	06595A	08158	08158	08143	08143	Sealing Washer	EPDM and Stainless Steel	1	1	1	1	1
8	*	*	*	*	*	Clapper	Teflon® Coated HR Steel UNS-G10180	1	1	1	1	1
9	*	*	*	*	*	Clapper Rubber	EPDM, ASTM D2000	1	1	1	1	1
10	*	*	*	*	*	Clapper Rubber Retainer	Stainless Steel, UNS-S30400	1	1	1	1	1
11	06595A					H.H.C. Screw #10-24 UNC x 1/2" (12.7 mm) lg.	Stainless Steel, UNS-S30400	1	0	0	0	0
		10194	10194			Screw, Button Head, Socket, 3/8" - 24 UNF x 1/2"	Stainless Steel, UNS-S30400	0	1	1	0	0
				10308		Screw, Button Head, Socket, 1/2" - 20 UNF x 3/4" (19.1 mm) lg.	Stainless Steel, UNS-S30400	0	0	0	1	1
					10686	Screw, Button Head, Socket, 1/2" - 20 UNF x 7/8"	Stainless Steel, UNS-S30400	0	0	0	0	1
12	--	--	--	--	--	Seat	Brass, UNS-C84400	1	1	1	1	1
13	05354B	05354B	04649B	04992B	05339C	Cover Gasket	EPDM, ASTM D2000	1	1	1	1	1
14	01517A	01517A	01517A			H.H.C. Screw 3/8"-16 UNC x 3/4" (19,1 mm) lg.	Steel, Zinc Plated	4	4	6	0	0
				04993A		H.H.C. Screw 1/2"-13 UNC x 7/8" (22,2 mm) lg.	Steel, Zinc Plated	0	0	0	6	0
					01922A	H.H.C. Screw 5/8"-11 UNC x 1-1/4" (31,8 mm) lg.	Steel, Zinc Plated	0	0	0	0	6
15	--	--	--			1/2" (15 mm) NPT Pipe Plug	Steel	2	2	2	0	0
				--	--	3/4" (20 mm) NPT Pipe Plug	Steel	0	0	0	2	2

-- Indicates replacement part is not available

\* Indicates replacement part only available in a Sub-Assembly listed below.

**Sub-Assemblies**

3, 6-11	05499B	08518	08519	08520	08521	Clapper Assembly
9, 10	--	14864	14865	14866	--	Replacement Clapper Rubber Kit*

\*Clapper rubbers are different on 3", 4", & 6" G-1 valve than original manufacture. If clapper rubber requires replacement, order replacement rubber kit.