	<h1 style="margin: 0;">TECHNICAL DATA</h1>	<h2 style="margin: 0;">SOLENOID VALVES</h2> <p style="margin: 0;">RATED TO 250 PSI (17.2 BAR)</p>
---	--	---

The Viking Corporation, 210 N Industrial Park Drive, Hastings MI 49058
Telephone: 269-945-9501 Technical Services: 877-384-5464 Fax: 269-818-1680 Email: techsvcs@vikingcorp.com

1. DESCRIPTION



The high pressure solenoid valve is a two-way type with one inlet and one outlet. It is a packless, internal pilot operated valve, suitable for use in releasing water pressure from the priming chamber of Viking Model E and F Series Deluge Valves and Viking Model H and J Series Flow Control Valves. The solenoid valve has floating diaphragm construction, which requires a minimum pressure drop across the valve to operate properly. The valves are available with a voltage rating of 24V DC in a normally closed or normally open configuration. These solenoid valves are for use with system control units that are listed and/or approved for releasing service for water based fire protection systems.



Features

1. Normally Closed or Normally Open
2. 24 VDC
3. Easy to clean
4. Body Style: Straight through
5. NEMA 1 through 9. (See Table 1)
6. Required Accessories: A 50 mesh strainer must be installed on the inlet side of the valve at the priming line connection. This strainer is included as part of the Model E or F Deluge Valve Trim and Model H or J Flow Control Valve Trim.

2. LISTINGS AND APPROVALS (see table 1 for specific model approvals)

-  **UL Listed:** VLTR
-  **FM Approved**
- CSA:** Standard C22.2
-  **CE Certified:** Part Nos. 11601, 11602, 13215, 13843 and 13844

3. TECHNICAL DATA

Specifications

Coil: Class H, Continuous Duty
 Maximum Operating Pressure: 250 psi (17.2 bar)
 Minimum Operating Pressure: 5 psi (0.35 bar)
 See Table 1 for enclosure descriptions and recommended ambient temperatures.

Material Standards

Body: Brass with 1/2" (15 mm) NPT connections
 Seals and Discs: Buna N
 Core Tube: 305 Stainless Steel

Viking Technical Data may be found on The Viking Corporation's Web site at <http://www.vikinggroupinc.com>. The Web site may include a more recent edition of this Technical Data Page.

Table 1 - Part Numbers and Specifications													
Description	Model	Part Number	For Viking System	Orifice	Wattage	DC Current	Max. Ambient Temp.	Cv Factor	Listings & Approvals				
									UL ⁴	CSA	FM	LPCB	CE
Normally Closed NEMA 1,2,3,3S,4,4X ¹	24 VDC	11601	Deluge & Preaction,	5/8"	9.0 DC	338 mA	130 °F (54 °C)	4.0	Yes ⁴	Yes ²	Yes ⁵	--	Yes
Normally Closed Explosion Proof NEMA 3,3S,4,4X,6,6P,7,9 ¹	24 VDC	11602		SureFire	5/8"	9.0 DC	338 mA	130 °F (54 °C)	4.0	Yes ⁴	Yes ³	Yes ⁵	--
Normally Open NEMA 1,2,3,3S,4,4X ¹	24 VDC	13215	Surefire	5/8"	9.0 DC	338 mA	130 °F (54 °C)	4.0	Yes ⁴	Yes ²	Yes ⁵	--	Yes
Normally Closed NEMA 1,2,3,3S,4,4X ¹	24 VDC	13843	Deluge & Preaction	5/8"	2.0 DC	250 mA	140 °F (60 °C)	4.0	Yes ⁴	Yes ²	Yes ⁵	--	Yes
Normally Closed Explosion Proof NEMA 3,3S,4,4X,6,6P,7,9 ¹	24 VDC	13844		5/8"	2.0 DC	250 mA	140 °F (60 °C)	4.0	Yes ⁴	Yes ³	Yes ⁵	--	Yes

Footnotes

¹ Enclosure types: 1 - General Purpose, 2 - Drip-Proof, 3 and 3s - Rain Tight, 4 and 4X - Water Tight, 7 - Explosion Proof Class I Groups A, B, C and D, 9 - Dust Ignition Proof Class II Groups E, F & G.

² CSA recognized to CSA Standards C22.2 number 0 and number 129.

³ CSA recognized to CSA Standards C22.2 numbers 0, 139, 25 and 30. Certified for hazardous locations Class I, Groups A, B, C and D; Class II, Groups E, F and G.

⁴ UL Listed - VLTR.

⁵ FM Approved



TECHNICAL DATA

SOLENOID VALVES
RATED TO 250 PSI (17.2 BAR)

The Viking Corporation, 210 N Industrial Park Drive, Hastings MI 49058

Telephone: 269-945-9501 Technical Services: 877-384-5464 Fax: 269-818-1680 Email: techsvcs@vikingcorp.com

Core and Plugnut: 430F Stainless Steel
 Springs: 302 Stainless Steel

4. INSTALLATION

1. Check nameplate for correct unit, including voltage and mode of operation. Follow all installation and maintenance instructions enclosed with the valve.
2. Standard solenoids may be mounted in any position. However, for optimum life and performance, solenoids should be mounted vertically and upright with the coil upright.
3. A 50 mesh strainer is required on the inlet side of the valve at the priming line connection. This strainer is included as part of the Model E & F Deluge Valve Trim and Model H or J Flow Control Valve Trim. Install the strainer as indicated on Viking's trim drawing. Install the solenoid according to markings on the valve body. Apply pipe-joint compound sparingly to male pipe threads only. If applied to valve threads, it may enter the valve and cause operation difficulty or leakage. Avoid putting pipe compound on first two male threads as well.
4. The unit must be wired in accordance with local and national electrical codes. For valves equipped with water tight enclosures, the electrical fittings must be approved for use in the hazardous location.
5. Upon completing the installation, the entire system must be tested for proper operation. See system description and testing instructions for additional information.

5. OPERATION

The solenoid valve is an internal pilot operated valve with pilot and bleed orifices utilizing line pressure for operation. Normally closed, de-energized valves open when energized. Power is applied to the solenoid coil, causing the solenoid core to lift, opening the pilot orifice to the outlet side of the valve. This relieves pressure on the top side of the diaphragm and allows the line pressure to open the valve. When de-energized, the solenoid core reseals the pilot orifice, allowing the line pressure to build above the diaphragm, closing the valve.

Normally closed solenoid valves are commonly used as releases for Viking deluge and flow control valves. Opening the solenoid valve allows the deluge or flow control valve to open.

Note: When using a normally closed solenoid valve as a release, a system will not operate automatically on total loss of power. For this reason, it is recommended and normally required that an emergency battery back-up, supervised power supply be provided to maintain fire protection during interruptions of the main power system and to meet the requirements of appropriate Authorities Having Jurisdiction.

6. INSPECTIONS, TESTS AND MAINTENANCE

WARNING

Any system maintenance that involves placing a control valve or detection system out of service will impair the fire protection capabilities of that system. Prior to proceeding, appropriate impairment procedures per NFPA 25 shall be followed with the notification of all Authorities Having Jurisdiction. Consideration should be given to employment of a fire patrol in the affected areas.

Failure to follow these instructions could cause improper system operation, resulting in serious personal injury and/or property damage.

WARNING: PRIOR TO OPERATING THE SOLENOID VALVE, BE SURE TO CLOSE THE SYSTEM CONTROL VALVE TO AVOID UNINTENTIONAL OPERATION OF THE DELUGE VALVE.

1. Inspections: It is imperative that the system is inspected and tested on a regular basis in accordance with NFPA 25. The frequency of the inspections may vary due to contaminated water supplies, corrosive water supplies, or corrosive atmospheres. In addition, the alarm devices, detection systems, or other connected trim may require a more frequent schedule. Refer to the system description and applicable codes for minimum requirements.
2. The valve must be operated at least monthly. The valve must open and close freely. When open, the water flow must be clear and clean at the proper flow rate. When closed, a total water shut-off must be observed. After the test, the strainer must be cleaned. Prior to cleaning the strainer, the priming line valve must be closed and the priming line depressurized. After the strainer is cleaned, the priming line valve must be reopened.
3. The valve must be inspected at least monthly for cracks, corrosion, leakage, etc., and cleaned, repaired, or replaced as necessary.
4. At least annually, the valve diaphragms and seats must be inspected and, if necessary, repaired or replaced.

WARNING: CLOSE SYSTEM CONTROL VALVE, TURN OFF POWER SUPPLY, AND DEPRESSURIZE VALVE BEFORE DISASSEMBLING VALVE. IT IS NOT NECESSARY TO REMOVE THE VALVE FROM THE PIPE LINE TO MAKE INSPECTIONS.



TECHNICAL DATA

SOLENOID VALVES
RATED TO 250 PSI (17.2 BAR)

The Viking Corporation, 210 N Industrial Park Drive, Hastings MI 49058

Telephone: 269-945-9501 Technical Services: 877-384-5464 Fax: 269-818-1680 Email: techsvcs@vikingcorp.com

5. When lubricating valve components, use a high grade silicone grease (Dow Corning® 111 Compound Lubricant or equal).
6. When reassembling, tighten parts to torque values indicated in ASCO's maintenance instructions (packed with valve).
7. After maintenance is completed, operate the valve a few times to be sure of proper operation. A metallic "click" signifies the solenoid is operating.
8. It is recommended that the valve be replaced at seven-year intervals. Shorter intervals may be required if the valve is subject to corrosive water supplies or atmospheres.
9. All service must be performed by qualified personnel. Upon completion of inspections or replacement of the valve, the entire system must be checked for proper operation. See appropriate system description and testing instructions for additional information.

7. AVAILABILITY

The Viking Solenoid Valve is available through a network of domestic and international distributors. See the Viking Corp. Web site for closest distributor or contact The Viking Corporation.

8. GUARANTEE

For details of warranty, refer to Viking's current list price schedule or contact Viking directly.

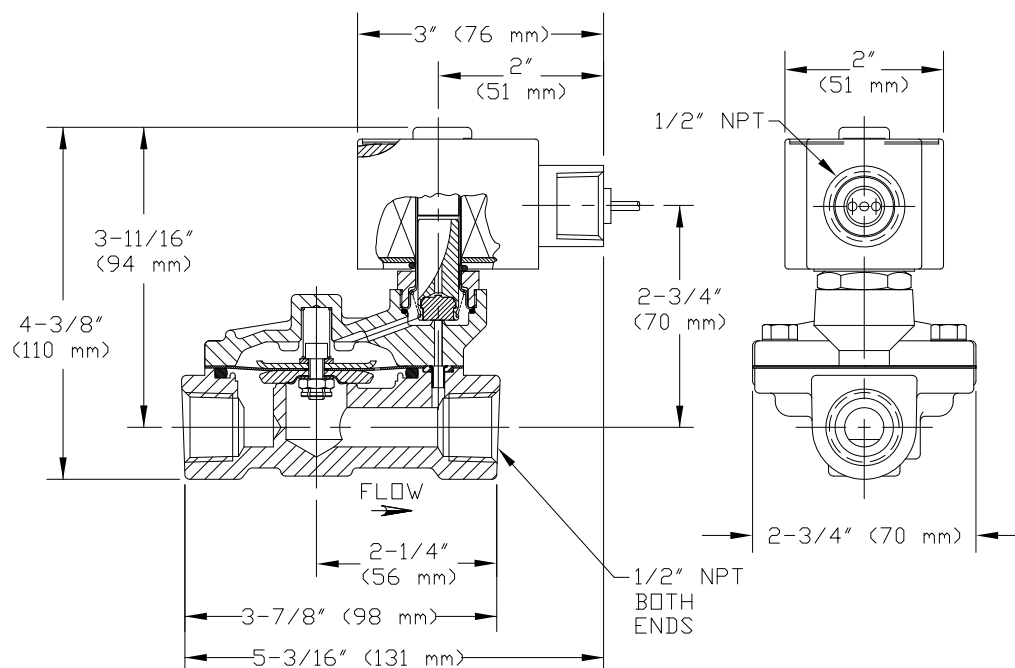

Figure 1

Dimensions for Part Numbers 11601 and 13215



TECHNICAL DATA

**SOLENOID VALVES
RATED TO 250 PSI (17.2 BAR)**

The Viking Corporation, 210 N Industrial Park Drive, Hastings MI 49058

Telephone: 269-945-9501 Technical Services: 877-384-5464 Fax: 269-818-1680 Email: techsvcs@vikingcorp.com

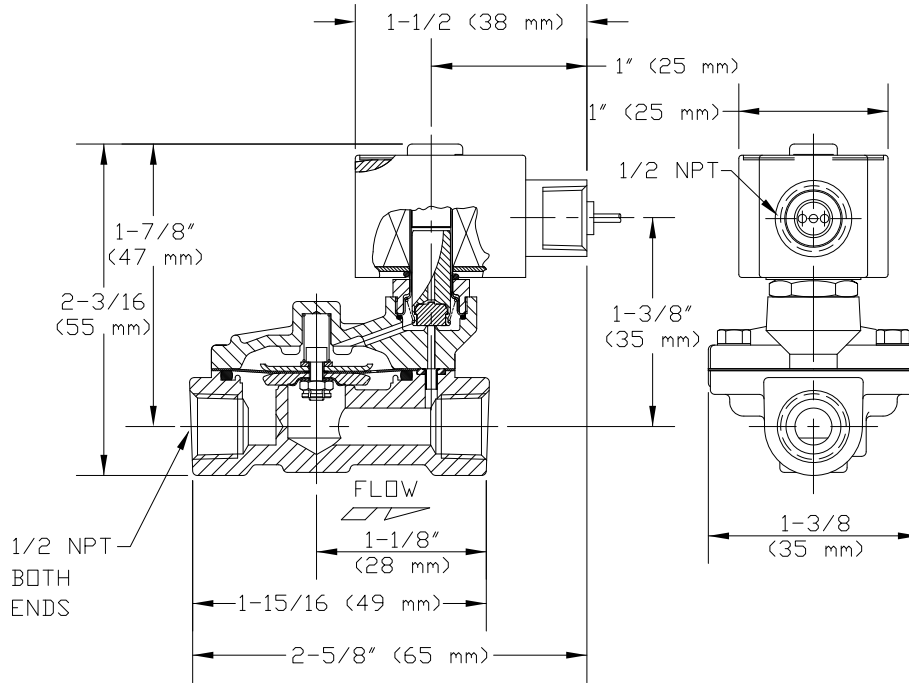

**Figure 2
Dimensions for Part Number 11602**

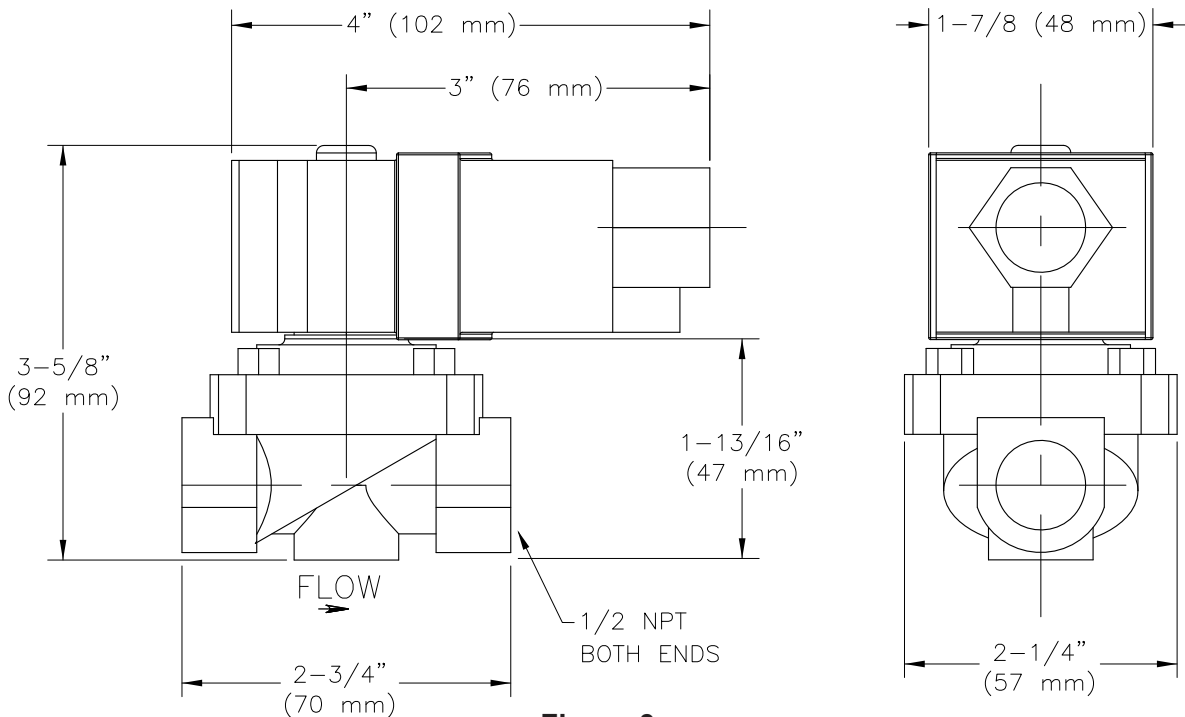

**Figure 3
Dimensions for Part Numbers 13843 and 13844**