

# VFR-400 Installation, Operation, and Instruction Manual

## Releasing Panel for Sprinkler Systems

All specifications subject to revision.





**NOTES:**

# TABLE OF CONTENTS

<b>Operating Instructions Form</b> .....	<b>1</b>
<b>Design Guidelines</b> .....	<b>1</b>
<b>General Description</b> .....	<b>2</b>
<b>System Features</b> .....	<b>2</b>
Options <i>Refer to Appendix A of the manual for product data sheets.</i> .....	4
Specifications.....	4
VFR-400 Visual Indicators: Visible with Door Closed .....	4
LCD .....	5
VFR-400 Visual Indicators .....	5
Control Buttons .....	5
<b>Circuit Parameters</b> .....	<b>6</b>
Initiating Device Zones .....	6
Dedicated Supervisory Zones.....	6
Notification/Release Circuits.....	6
Low/Missing Battery .....	7
Input Power .....	7
Backup Power Requirements .....	7
Service Use.....	8
Listings & Approvals.....	8
Terminals .....	8
Relay Outputs .....	8
Auxiliary Power.....	8
Annunciator Connection.....	8
CA2Z Module (Class A Initiating Device Circuit).....	8
ARM-44 (Auxiliary Relay Module) .....	8
CAM Module (Class A Indicating Appliance Circuit) .....	8
ARM-1/ARM-2 Module (Auxiliary Relay Module).....	8
RA-4410RC (Remote Annunciator).....	8
RCDS-1 (Release Circuit Disconnect Switch).....	8
<b>Basic Operation</b> .....	<b>8</b>
Initiating Device Circuits Alarm Condition .....	9
Alarm .....	9
Low Air Alarm.....	9
Supervisory.....	9
Trouble Conditions .....	10
Loss Or Reduction Of AC Power .....	10
Notification Appliance/Releasing Circuits .....	10
Low Battery Voltage.....	11
Loss Of Auxiliary Power Output.....	11
To Silence The Buzzer Or Outputs That Have Been Described As Trouble Or Supervisory Bell.....	11
<b>To Silence A Signaling Appliance</b> .....	<b>11</b>
To Reset an Alarm or Supervisory Condition.....	11
To Reset A Trouble Condition .....	11
Lamp Test .....	11
<b>Remote Annunciator Model RA-4410RC Operation</b> .....	<b>12</b>
Basic Operation .....	12
<b>Installation Instructions</b> .....	<b>12</b>
Mounting Instructions .....	13
<b>Wire Checkout</b> .....	<b>13</b>
<b>Battery Size Requirements And Maintenance</b> .....	<b>14</b>
Inactive Circuits.....	14
<b>Battery Size Calculations</b> .....	<b>14-16</b>
<b>Connection Procedure for Battery Charging Current and Voltage</b> .....	<b>15</b>
<b>Connection Drawing for Central Station and Remote Station Operation</b> .....	<b>15</b>

**Wire Routing for VFR-400.....17**  
**NEC Section 760-54. Installation of Conductors and Equipment.....17**  
**Connection Drawing .....19**  
**Remote Annunciator Model RA-4410RC Test Procedures .....20**  
**Programming Mode Instructions .....21**  
**Panel Visual Display .....21**  
    History ..... 21  
    Date/Time ..... 21  
    Password..... 22  
    Zone Disabled/Enabled ..... 22  
    Output Enable/Disable..... 23  
    One Man Walktest ..... 23  
**VFR-400 Standard Program Information/Wiring Diagrams .....24-68**  
**VFR-400 Custom Program Information/Water Based Extinguishing .....70-73**  
**VFR-400 Custom Program Information/Chemical Based Extinguishing .....74-79**  
**2-Wire Smoke Detector And Synchronization Module Compatibility Data .....80**  
**4-WIRE HEAT DETECTOR COMPATIBILITY IDENTIFIER “A” .....81**  
**viking Firecycle normally closed heat detectors.....81**  
**Releasing Device Compatibility .....81**  
**agent Releasing systems Compatibility .....81**  
**NAC Compatibility Chart.....82**  
**4-Wire Smoke Detectors/Devices .....83**  
**Appendix a: Product Datasheets of optional Equipment.....85**



**This is the safety alert system. It is used to alert you to potential personal injury hazards. Obey all safety messages that follow this symbol to avoid possible injury or death.**

## **WARNING**

- The detection and suppression system employing this release panel must be designed by people trained and competent in the design and layout of fire alarm and/or suppression systems for special hazard locations. The system shall be designed and installed in accordance with all local and national codes and ordinances as well as the approval of the Authority Having Jurisdiction. Only trained, qualified and competent individuals should install, program and/or service the VFR-400. Competent people would be aware of these warnings, limitations, and requirements.
- High voltage electrocution hazard. Do not handle live AC wiring or work on the device while ac power is active. This manual is designed to help with the specification, installation, and programming of the VFR-400 release panel. It is imperative that this manual be completely read and understood before the installation or programming of the panel. Save this manual for future reference.
- Zones programmed as MANUAL RELEASE will override any cross zoning features. If it is desired to not have a Manual Release override the cross zoning, program the zone as DETECTION and map accordingly.

## **CAUTION**

- \*Locate the panel and all system components in the following nominal environment:
- \*Indoor heated installation only, preferably an interior wall.
- \*Verify that the wire sizes are adequate for all initiating, notification, and release circuits.
- \*Make certain the panel is properly grounded.
- \*Remove all electronic assemblies prior to any drilling, filing, reaming, or punching of the enclosure. When possible make all cable entries from the sides, bottom, or rear of the cabinet. Verify that they will not interfere with the batteries or other components.
- \*The panel and system must be tested and maintained in accordance with all local and national codes and ordinances.

### **OPERATING INSTRUCTIONS FORM**

1. Fill in the name, address and telephone number of the servicing agency on the instruction sheet provided. Frame and place the sheet adjacent to the control panel at eye level.
2. The following documentation shall be delivered to the owner or their representative upon final acceptance of the system:
  - An owner's manual and installation instructions covering all system equipment.
  - Wiring diagrams
  - A detailed description of the programming and operating sequence of the system.

## **WARNING**

### **Fire Alarm System Limitations**

Smoke detectors may not detect smoke when the smoke does not reach the detector. Such as smoke within walls, on the other side of walls, on other floors, behind closed doors, explosions, etc. Smoke detectors will not operate if they are not properly connected to the fire/release panel. The detectors and bases must be UL/ULC listed as being compatible with the panel. The detectors have a visible flashing light that indicates power is supplied to the detectors.

Notification appliances may not alert people if the people are not able to hear or see the appliances such as if they are in separate areas of the building or room.

A fire alarm/release panel will not operate without electrical power. The panel must have sufficient backup battery capability to power the panel for a specified amount of time in the event of an AC power failure. The batteries and release panel shall be tested and maintained in accordance with the testing and maintenance requirements of NFPA 72.

In order for emergency forces, (Fire departments, etc.), to respond to events associated with this panel, the panel must transmit trouble, supervisory, and alarm signals to a monitoring facility either directly or through a main building fire panel.

A problem in an audible or visual device may not be apparent when the panel is in a normal condition.

### **DESIGN GUIDELINES**

People trained in the design of special hazard systems shall determine the selection and placement of the initiating devices and notification appliances connected to the VFR-400. This responsible party shall also be familiar with the premises being protected. The equipment shall be installed in accordance with the manufacturers instructions, the applicable version of NFPA 72 and all local codes and ordinances. For systems employing cross zoning of two smoke detectors for the activation of the release circuit, this can include but is not limited to the installation of photoelectric and ionization types of detectors on separate zones. One of each type

of detector on separate zones shall be installed in the coverage area selected for a single detector (not to exceed 0.7 times the linear spacing). The detectors would be installed in close proximity to each other.

The responsible party shall also determine the theory of operation regarding the programming sequence.

NOTICE TO USERS, INSTALLERS, AUTHORITIES HAVING JURISDICTION, AND OTHER INVOLVED PARTIES			
This product incorporates field-programmable software. In order for the product to comply with the requirements in the Standard for Control Units and Accessories for Fire Alarm Systems, UL 864, certain programming features or options must be limited to specific values or not used at all as indicated below.			
Programmable Feature or Option	Permitted in UL 864: Y/N	Possible Settings	Setting Permitted in UL 864
VFR-400 Panel Programs #6 - #9 Employing Firecycle Detector	No	Programs 1-16, 20-24	Programs 1,2,3,4,5,10,11,12,20-24
VFR-400 Panel Program #13 - #15	No	Programs 1-16, 20-24	Programs 1,2,3,4,5,10,11,12,20-24
VFR-400 Panel Program #16 - Employing Firecycle Detector	No	Programs 1-16, 20-24	Programs 1,2,3,4,5,10,11,12,20-24
VFR-400 Panel Custom Programs - Employing Firecycle Detector Selection	No	Firecycle, Detection, Waterflow, Linear Heat Detection, Manual Release.	Detection, Waterflow, Linear Heat Detection, Manual Release.
NY Abort (Mode 3)	No	Mode 1, 2, 3, or 4	Modes 1 and 2
30-Second Abort (Mode 4)	No	Mode 1, 2, 3, or 4	
Abort on Pre-action or Deluge Systems	No	Supervisory, Tamper, Low air, High Air, Abort	Supervisory, Tamper, Low Air, High Air

**GENERAL DESCRIPTION**

The model VFR-400 is a listed and approved, microprocessor based fire control/releasing panel. It is primarily designed for use as a releasing panel for pre-action, Surefire®, Firecycle® III, and deluge, water based extinguishing systems. They may also be used as stand alone fire control panels. These units comply with NFPA 11, NFPA-13, NFPA-15, NFPA-16, NFPA-72, and NFPA-750, 12, 12A, and 2001.

The VFR-400 complies with UL Standard 864, ULC S527-77, Canadian Electrical Code Part 1 C22.1, ULC S524, FM, CSFM and NYMEA.

**ADDITIONAL INFORMATION**

For Firecycle operation see Viking technical data sheet F\_051304, F\_051404 or F\_051504.

For SureFire operation see Viking technical data sheet F\_051604 or F\_051704.

**SYSTEM FEATURES**

• Four Class B (Style B) Initiating zones. Each initiating zone can be set up for any of the following:

- **Alarm Zones**
- Detection alarm zone
- Waterflow
- Linear Heat Detection up to 700 ohms per zone.
- Manual Release
- Viking Firecycle Detectors (Zone 1 only)
- **Supervisory Zones**
- Supervisory
- Tamper
- Low Air Supervisory
- High Air
- Low Air Alarm

**NOTE:** Only zones programmed as Detection, Waterflow, Linear Heat, Manual Release, Firecycle and Low Air Alarm can be mapped to outputs programed as release.

- Remote Annunciator Output for connection to RA-4410RC:
  - RS-485 communication, (2-wire shielded cable required)
  - Regulated 24VDC annunciator power
- Two Supervisory Zones, Class B (VDC Style B). These zones can be set up for any of the following:
  - Supervisory
  - Tamper
  - Low Air Supervisory
  - High Air
  - \* Abort (Supervisory zone 1 only)

NOTE: \* Abort on a water-based extinguishing system is not a UL Listed function.
- Four Class B (Style Y) Output circuits. Each output can be set up for any of the following:
  - Notification Appliance circuit
  - Releasing circuit
  - Supervisory Bell circuit
  - Trouble Bell circuit
- One Abort Circuit (Available in Chemical Mode only) Programmable for four different operating modes
  - ULI – Stops the pre-discharge timer at 10 seconds
  - IRI – Abort must be activated before the second alarm is received
  - NYC (not UL listed) A one time operation that adds 90 seconds to the remaining pre-discharge time
  - \* 30 Second Abort (stops or reverts the pre-discharge timer at 30 seconds)

NOTE: \* Not a UL Listed function

## CAUTION

Abort does not function and has no effect on panel operation from zones programmed as MANUAL RELEASE.

- Sixteen Standard Programs for water based systems or custom program capability
- Five Standard Programs for Chemical based systems or custom program capability
- User selectable between Water Based or Chemical Extinguishing
- Releasing Zones can be set up for either normal or cross zoning operation
- All circuits inherently power limited per NEC 760 and UL 864 Section 14.4
- Initiating Circuit Disable feature
- Output Disable feature
- One-Man Walktest feature with automatic 30 minute restoration and releasing circuit disable
- Class B (Style B) Abort circuit available in Chemical mode. Three Abort modes available
- Pre-Discharge timer from 0-60 seconds available in Chemical mode only
- Manual Release 0-30 seconds pre-discharge timer in Chemical Mode only
- Notification Appliance Circuits can be programmed to operate upon 1<sup>st</sup> or 2<sup>nd</sup> alarm in Chemical Mode for pre-discharge signal
- Diagnostic Indicators
- Signal Silence button
- Manual Event scroll buttons
- Automatic resound of silenced trouble signals after 24 hours
- Built-in Trouble buzzer
- Common Relay Contacts for Alarm/Trouble/Supervisory/Waterflow
- 32 Character Liquid Crystal Display (LCD)
- 34 LED Display
- AC, Alarm, Supervisory, Trouble, Alarm silenced LED's (Pre-discharge/discharge LED)
- User Generated Banner Message
- User Generated Zone Labeling
- 24 or 90 hour Battery Standby available (Where required by FM and Others)
- 24 Hour Clock
- Password Protection
- Remote annunciator output
- Resettable 4-wire smoke detector power



**Options Refer to Appendix A of the manual for product data sheets.**

1. CAM - Module to convert one Class B Indicating Appliance Circuit to one Class A circuit.
2. CA2Z - Module to convert two Class B Initiating Device Circuits to two Class A circuits.
3. ARM-1 - Module to provide non-supervised 4PDT Relay designed to be activated by 24VDC Indicating and/or Releasing, polarity reversing circuits.
4. ARM-2 - Module to provide two Form C contacts activated by Indicating or Releasing, polarity reversing circuits
5. ARM-44 - Module to provide 8 independent Form C relay outputs. Contact manufacture for data sheet 5401202.
6. RA-4410RC – Remote annunciator provides 34 LED's for each zone in alarm supervisory or trouble, each output activated or in trouble, AC power, Power trouble, System trouble, Ground fault, Supervisory, Supervisory trouble, Alarm, Alarm silence and Pre-discharge/Discharge. The RA-4410RC can be mounted in a 4 gang electrical box or use a surface mount back box such as the BB-RA-44R. Contact manufacture for data sheet 5401175.

**WARNING**

This equipment generates, uses, and can radiate radio frequency energy and if not installed and used in accordance with the instruction manual, may cause interference to radio communications. It has been tested and found to comply with the limits for a Class A computing device pursuant to Subpart J of Part 15 of FCC Rules which are designed to provide reasonable protection against such interference when operated in a commercial environment. Operation of this equipment in a residential area is likely to cause interference in which case the user at his own expense will be required to take whatever measures may be required to correct the interference.

**Specifications****VFR-400 HOUSING**

Type - 18 gauge sheet steel with hinged, removable, locked door

Size - 18 1/2" x 14 5/8" x 4 3/4"

Finish - red cabinet with logo.

Knockouts - 4 - 1/2" and 2 - 3/4" on top; 1 - 1/2" and 1 - 3/4" each side; 2 - 1/2" and 1 - 3/4" back

**VFR-400 Visual Indicators: Visible with Door Closed**

AC LED - Green

Alarm Silenced - Amber

System Alarm LED - Red

System Supervisory LED- Amber

System Trouble LED - Amber

Pre-discharge/Discharge LED - Amber

32 Character Alpha-Numeric Liquid Crystal Display (LCD)

Red alarm per zone

Amber trouble LED per zone

Common required systems status LED's

**LCD**

A 2 line 32 character alpha-numeric liquid crystal display shows the condition, status and circuit for all Alarm, Supervisory and Trouble conditions:

<b>CONDITION</b>	<b>STATUS</b>	<b>CIRCUIT</b>
Alarm		<user Defined Message> (Up To 10 Characters)
Trouble	Disabled	Output #1
Supervisory	Acknowledged	Output #2
Tamper	Silenced	Output #3
Low Air		Output #4
High Air		Battery
		A.C.
Pre-discharging		Supervisory
Releasing		Zone #1
Released		Zone #2
		Zone #3
		Zone #4
		Ground

**VFR-400 Visual Indicators**

In accordance with ULC S527-99 option B:  
LED Annunciator Module

Red LED's: Initiating Device Circuits Active (4),  
Notification/Release Circuits Active (4)  
Common Alarm (1)

Green LED: AC Power

Yellow LED's: Initiating Device Circuits Troubles (4),  
Output Circuits Troubles (4)  
Supervisory Initiating Zone (4)  
Supervisory Bell Output Active (4)

(1) each: Supervisory 1, Supervisory 2, Power Trouble, Supervisory Trouble, System Trouble, Ground Fault, Pre-Discharge/Discharging, Alarm Silenced

<b>CONDITION</b>	<b>STATUS</b>	<b>LED State</b>
Trouble	Non-Silenced	Flashing
Trouble	Silenced	Steady ON
Alarm	Non-Silenced	Flashing
Alarm	Silenced	Steady ON
Supervisory	Non-Silenced	Flashing
Supervisory	Silenced	Steady ON
Pre-discharge		Flashing
Discharging		Steady ON

**Control Buttons**

- Signal Silence - Momentary, silences signaling circuits, (except those activated by zones programmed as WATERFLOW)
- System Reset - Momentary, resets all alarm circuits if condition has been corrected, removes power from initiating device circuits.
- Scroll Up - Scrolls LCD display to most recent events
- Scroll Down - Scrolls LCD display to previous events

**NOTE:** Buzzer silence is accomplished by scrolling through all events.

## CIRCUIT PARAMETERS

All voltages regulated DC

### Initiating Device Zones

For connection of dry contact initiating devices and compatible 2 wire smoke detectors. (All values nominal)

- 4 Class B, Style B (Class A Style D module available)\*
- Power limited, current limited to protect 2 wire smoke detectors
- Maximum 2 wire 24VDC smoke detector load per zone - 2.5 ma (Use only detectors that are listed in compatibility list.)
- Maximum Line resistance - 100 ohms (Except linear heat detection cable, 700 ohms per zone)
- End-of-Line Resistance - 5.1K ohms
- Normal standby current - approximately 4.0 mA
- Standby voltage - 25VDC maximum, 13.4 minimum
- Maximum short circuit current - approximately 36mA
- Maximum Impedance for Alarm - 1400 ohms
- Normal supervisory current - approximately 4mA
- Low current trouble activation - approximately 3.3mA
- Alarm activation current - approximately 10mA
- Ripple voltage - .4 VDC
- Maximum operating voltage range: 22.5 - 25.9V DC
- Frequency - continuous

\* In programs 6-9, Zone 1 is a normally closed zone for Firecycle® Detectors

### Dedicated Supervisory Zones

- For dry contact supervisory devices such as tamper, low air, or high air switches
  - 2 Class B Style B circuit, latching
  - Power limited, current limited
  - End-of-Line resistance - 5.1K ohms
  - Ripple Voltage - .1 VDC
  - Frequency - continuous
  - Maximum voltage - 25VDC
  - Maximum short circuit current - approximately 36mA
  - Maximum line resistance - 100 ohms
  - Normal supervisory current - approximately 4mA
  - Low current trouble activation - approximately 3.3mA
  - Supervisory current condition - approximately 10mA
- (Does not include power for any auxiliary devices)

### Notification/Release Circuits

The indicating circuits of the VFR-400 are Non-coded. This allows the use of visual and audible appliances on the same circuit. If temporal notification appliances are required for evacuation, selectable tone appliances shall be used.

The notification outputs do not provide synchronization. See table for sync options and devices on page 82. The notification appliances shall be compatible with the sync module selected. The sync module shall be installed as per manufacturers instructions. Synchronization is limited to only one circuit and not between circuits. Systems intended for the release of Halon 1301 as described in NFPA 12A, or clean agents as described in NFPA 2001, shall have provision for a pre-discharge notification circuit. If the signal is required to be separate and/or distinct from the evacuation signal, two notification circuits are required. One shall be programmed as FIRST ALARM. It will provide a steady output upon activation of any initiating zone programmed as an alarm zone. This is the evacuation signal. If a temporal signal is required, notification appliances that can produce a temporal tone shall be used. This allows the use of strobes and horns on the same circuit. The other notification circuit shall be programmed as SECOND ALARM. It will provide a steady output upon activation of a second initiating zone programmed as an alarm zone. This is when the pre-discharge timer would start and would be the pre-discharge signal. If a temporal or other type of signal is required, notification appliances shall be used. This allows the use of strobes and horns on the same circuit. If a separate signal for discharge were required, a third notification circuit would be used that would be programmed to operate whenever the release circuit is activated. Equivalent sync modules are shown on page 82.

Zones programmed as MANUAL RELEASE will activate outputs programmed as SECOND ALARM, even if the MANUAL RELEASE zone is the first alarm zone activated. SECOND ALARM is intended to be used as a pre-discharge signal for cross zone applications. Refer to page 57 for a complete description of first and second alarm requirements and operation.

- 4 Class B Style Y (Class A Style Z module available for notification)
- Reverse polarity upon activation
- Power limited, Current limited
- 24 VDC Special Application, rated 1 amp each, 2.5 amps total for all 4 circuits
- End-of-Line-Resistor - 5.1k ohms
- Frequency - continuous
- Maximum voltage - 27 VDC
- Ripple voltage - .3 VDC
- Maximum resistance for outputs programmed as RELEASING:  
1 divided by the current draw of the solenoid when activated
- Normal standby supervisory current - approximately .38mA
- Low current trouble activation - .11mA
- Maximum impedance - 5 Ohms
- High current trouble activation - .63ma

**Release Abort Circuit**

- Available chemical mode only
- 1 momentary non-latching Class B Style B circuit
- Power limited, current limited
- Maximum loop resistance - 100 ohms
- End-of-Line-resistance - 5.1k ohms
- Frequency - continuous
- Normal supervisory current - approximately 4mA
- Low current trouble activation - approximately 3.3mA
- Abort current condition - approximately 10mA
- Maximum voltage - 23VDC

NOTE: Mode 3 is not UL Listed

- Mode 1 – (ULI) Activation of the abort circuit stops the pre-discharge timer at 10 seconds. If there is less than 10 seconds remaining, the time goes back to 10 seconds. Releasing the abort switch starts the timer at 10 seconds.
- Mode 2 – (IRI) Operates the same as the ULI mode except the abort circuit only functions if the abort button is pressed before the second alarm is received by the panel. The panel must be programmed for cross zoning for the IRI mode to function.
- Mode 3 – (NYC) This mode is not UL listed. Activation of the abort circuit during the pre-discharge countdown adds 90 seconds to the original pre-discharge time. This is a one-time feature. Repeated pressing of the abort button has no effect. The pre-discharge timer resumes when the abort button is released.
- Mode 4 – (30-Second Abort) This mode is not UL listed. Activation of the abort circuit stops the pre-discharge timer at 30 seconds. If there is elss than 30 seconds remaining, the timer goes back to 30 seconds. Releasing the abort switch starts the timer at 30 seconds.

 <b>CAUTION</b>
<p>Zones programmed as Manual Release cannot be aborted. If it is necessary to abort a manual station zone, program that zone as Detection.</p> <p>If the pre-discharge timer is set at 0 the abort circuit will not stop the release circuit.</p> <p>NFPA 12 prohibits the use of abort circuits on Suppression Systems employing carbon dioxide.</p>

**Low/Missing Battery**

Causes battery and system trouble if battery falls below 22 volts. Battery circuit is fused and reverse polarity protection is provided.

**Input Power**

- Universal Input 120VAC, (60 Hz, 165VA) or 220VAC, (50 Hz, 185VA) 15 Amp Branch Line overcurrent protection required
- AC power indicator on LED annunciator module is extinguished on AC power loss (supervised)
- System trouble is also generated if voltage drops below 102V

**Backup Power Requirements**

- VFR-400 - Standby 110 mA, alarm 245 mA at 24VDC

**Service Use**

NFPA 12 - Carbon Dioxide systems  
 NFPA 12A - Halon 1301 fire systems  
 NFPA 13 - Automatic Sprinkler  
 NFPA 15 - Water Spray Fixed System  
 NFPA 16 - Foam Water Sprinkler and Foam Water Spray  
 NFPA 17 - Dry Chemical  
 NFPA 17A - Wet Chemical  
 NFPA 72 - National Fire Alarm Code
 

- Local, Remote Station, Central Station (Protected premise unit)

 NFPA 750 - Water Mist  
 NFPA 2001 - Clean Agent Fire Extinguishing System

**Listings & Approvals**

VFR-400 - UL Standard 864, ULC Standard S527, FM, CSFM, NYMEA, and CE Marked.

**Terminals**

- All terminals capable of handling #22-14 AWG wire
- All terminations have transient protection
- All four initiating device circuit terminals capable of handling linear heat detection.

**Relay Outputs**

- Common system alarm contacts SPDT rated 3 Amps, 30VDC resistive
- Common supervisory contacts SPST, N.O. rated 3 Amps, 30VDC resistive
- Common system trouble contacts SPDT rated 3 Amps, 30VDC resistive
- Common system waterflow contacts SPST, N.O. rated 3 Amps, 30VDC resistive
- Circuits connected to relays should be connected within the same room

**Auxiliary Power**

- Auxiliary Power - 24VDC special application. Rated 200 mA max. Power limited, current limited, non-supervised
  - Resettable for 4-wire smoke detectors

**Annunciator Connection**

- Auxiliary Power - 24VDC regulated. Rated 200 mA max. Power Limited, current limited non-supervised for RA-4410RC Annunciator, non-resettable power
- RS-485 For connection to RA-4410RC remote annunciator
- Maximum 2000' with 22 AWG, 4000' with 20 AWG shielded cable

**Optional Accessories - see technical data sheets in Annex A at the back of this manual****CA2Z Module (Class A Initiating Device Circuit)**

Converts two Class B initiating device circuits to two Class A circuits.

**ARM-44 (Auxiliary Relay Module)**

To provide 8 independent Form C outputs connected to panel via RS-485 and 24 VDC power.

**CAM Module (Class A Indicating Appliance Circuit)**

Converts indicating appliance circuit from Class B to Class A. One model CAM (Class A Module) is required for each circuit. (Do not use this on an output programmed as "TROUBLE BELL".)

**ARM-1/ARM-2 Module (Auxiliary Relay Module)**

Activated by 24VDC Indicating and/or Releasing, polarity reversing circuits. The module provides a non-supervised DPDT Relay that can be used for fan shutdown, door release, elevator recall, etc.

**RA-4410RC (Remote Annunciator)**

Connects to RS-485 & 24VDC terminals. Provides 34 LED's for each zone in alarm supervisory, or trouble, each output activated or in trouble, AC power, Power trouble, System trouble, Ground fault, Supervisory, Supervisory trouble, Alarm, Alarm silence and Pre-discharge/Discharge.

**RCDS-1 (Release Circuit Disconnect Switch)**

Provides physical means of disconnecting release circuits in compliance with NFPA 72, 2007, 6.12.5.2.

**BASIC OPERATION**

In addition to the following events, the panel also provides an output via the RS-485 terminals to the RA-4410RC remote annunciator to light the appropriate indicators. See remote annunciator operations, page 12. In addition, the remote annunciator has a silenceable buzzer that sounds on supervisory or trouble conditions.

## Initiating Device Circuits Alarm Condition

An increase of current on any alarm initiating device circuit to approximately 10 mA or greater will result in the following:

### Alarm

(Except zones programmed as *LOW AIR ALARM*):

1. Activation of the common alarm relay contacts.
  2. Activation of the output circuit(s) which are mapped to the initiating device circuit(s). Providing all zone(s) necessary for the activation of those circuits is in alarm
  3. “ALARM” and zone # displayed on LCD.
  4. Activation of the red ALARM LED in a flashing mode as well as corresponding zone. **NOTE:** The ALARM LED will continue to flash until the Signal Silence button is pushed. The silence button will remove power from all outputs set up as Indicating except those activated by zones programmed as Waterflow.
  5. Activation of zones programmed as waterflow will operate the common waterflow relay contacts in addition to the above.
- NOTE:** If Zone 1 is programmed as Firecycle, an open circuit will result in the above.

### WARNING

Do not silence signals until all occupants are evacuated to a safe area.

### CAUTION

When in CHEMICAL EXTINGUISHING mode, the release circuit(s), are not activated until the pre-discharge timer expires, if a pre-discharge time was programmed. The predischarge time defaults to 30 seconds for Manual Release and 60 seconds for all other alarm tones.

### Low Air Alarm

1. Operation of supervisory relay contacts and local buzzer.
2. Activation of the notification appliance circuit(s) or releasing circuit(s) which are mapped to the initiating device circuit(s). Providing all zone(s) necessary for the activation of those circuits is in alarm
3. LOW AIR ALARM and <CIRCUIT #> displayed on LCD.
4. Activation of yellow ZONE indicator on LED annunciator module for the initiating device circuit.
5. Activation of yellow ZONE indicator(s) on LED annunciator module for the initiating device circuit(s) described as “LOW AIR ALARM”.
6. Activation of yellow OUTPUT indicator(s) on LED annunciator module for the output circuit(s) which are mapped to the zone. Providing all zone(s) necessary for the activation of those circuits is in alarm.
7. Activation of the amber supervisory LED in a flashing mode. **NOTE:** The supervisory LED will continue to flash until all events in the SUPERVISORY queue are viewed. This is accomplished by scrolling through all of the events by use of the scroll up and scroll down buttons. The LED will go steady after all alarm events have been viewed.

### Supervisory

An increase of current to approximately 8 mA or greater on the supervisory initiating device circuit(s) or disabling an output programmed as releasing will result in the following:

1. Operation of supervisory relay contacts and local buzzer.
2. Operation of any output circuits that have been described as SUPERVISORY BELL.
3. “SUPERVISORY”, “TAMPER”, “LOW AIR”, or “HIGH AIR” and <CIRCUIT> displayed on LCD.
4. Activation of yellow SUPERVISORY indicator on LED display.
5. Activation of yellow ZONE indicator(s) on LED display for the initiating device circuit(s) described as “SUPERVISORY”, “TAMPER”, “LOW AIR SUPERVISORY”, or “HIGH AIR”.
6. Activation of yellow OUTPUT indicator(s) on LED display for the Notification appliance circuit(s) described as SUPERVISORY BELL.
7. Activation of the amber SUPERVISORY LED in a flashing modes well as the corresponding zone LED. **NOTE:** The SUPERVISORY LED will continue to flash until all events in the SUPERVISORY queue are viewed. This is accomplished by scrolling through all of the events by use of the scroll up and scroll down buttons. The LED will go steady after all supervisory events have been viewed.

## Trouble Conditions

### Initiating Device Circuits

A decrease of current to approximately 3.3 mA or programming the zone as disabled on any initiating device circuit will result in the following:

1. Activation of trouble relay contacts and local buzzer.
2. Operation of any output circuits which have been described as TROUBLE BELL.
3. “TROUBLE” and <CIRCUIT> displayed on LCD.
4. Activation of the amber TROUBLE LED in a flashing mode as well as corresponding zone. **NOTE:** The TROUBLE LED will continue to flash until all events in the TROUBLE queue are viewed. This is accomplished by scrolling through all of the events by use of the scroll up and scroll down buttons. The LED will go steady after all trouble events have been viewed.
5. Activation of red ALARM indicator on LED display.
6. Activation of red OUTPUT indicator(s) on LED display module for the output circuit(s) which are mapped to the initiating device circuit(s).

**NOTE:** When the circuits are operated in the Class A mode any trouble condition will require manual operation of the **Reset switch** to restore the panel to normal after the fault has been removed.

A complete loss of power will result in the transfer of the common system trouble relay contacts.

If Zone 1 is programmed as Firecycle, an increase in current to 10 mA or greater will result in the above.

### Notification Appliance/Releasing Circuits

An increase of current to approximately 0.63 mA or a decrease in current to approximately 0.11 mA on any output circuit or connecting an indicating appliance backwards, or disabling an output will result in the following:

1. Activation of trouble relay contacts and local buzzer.
2. Operation of any output circuits which have been programmed as TROUBLE BELL. If this output is in trouble, a TROUBLE BELL on this output may not function correctly, depending on the type of trouble.
3. “TROUBLE” and “OUTPUT #” <CIRCUIT NO.> displayed on LCD.
4. Activation of yellow Output indicator(s) on LED display for the notification appliance(s)
5. Activations of yellow SYSTEM TROUBLE indicator on LED display.
6. Activation of yellow OUTPUT indicator(s) on LED display of any output circuit(s) which have been describes as TROUBLE BELL.

**NOTE:** A current in excess of 1.4 Amps, when the panel is in alarm condition, will result in that output being disables and a trouble as described above.

## CAUTION

A problem in an audible or visual device may not be apparent when the panel is in a normal condition. If the circuit indicates a trouble condition when the panel is in an alarm condition the problem must be located and corrected.

## Ground Fault

A short between any circuit and earth ground will result in the following:

1. Activation of trouble relay contacts, trouble LED in a flashing mode, and local buzzer.
2. Operation of any output circuits which have been described as TROUBLE BELL.
3. “TROUBLE” and “GROUND” displayed on LCD.

## Loss Or Reduction Of AC Power

A reduction in the AC input voltage will result in the following:

1. Trouble LED and local buzzer will sound 1½ hour delay of trouble relay.
2. Operation of any output circuits which have been described as TROUBLE BELL.
3. “TROUBLE” and “A.C.” displayed on LCD.
4. LCD Backlight will be extinguished.
5. Green AC POWER indicator on LED display will be extinguished.
6. Activation of yellow POWER TROUBLE indicator on LED display.
7. Activation of yellow SYSTEM TROUBLE indicator on LED display.
8. Activation of yellow OUTPUT indicator(s) on LED display of any output circuit(s) which have been described as TROUBLE BELL.

**Low Battery Voltage**

Loss of or reduction of battery voltage to 22 volts will result in the following:

1. Activation of trouble relay contacts, trouble LED and local buzzer.
2. Operation of any output circuits that have been described as TROUBLE BELL.
3. “TROUBLE” and “BATTERY” displayed on LCD.
4. Activation of yellow POWER TROUBLE indicator on LED display.
5. Activation of yellow SYSTEM TROUBLE indicator on LED display.
6. Activation of yellow OUTPUT indicator(s) on LED display of any output circuit(s) which have been described as TROUBLE BELL.

**Loss Of Auxiliary Power Output**

Loss of output of the auxiliary power will result in the following:

1. Activation of trouble relay contacts, trouble LED and local buzzer.
2. Operation of any output circuits that have been described as TROUBLE BELL.
3. “TROUBLE” and “AUX LOW” displayed on LCD.
4. Activation of yellow POWER TROUBLE indicator on LED annunciator module.
5. Activation of yellow SYSTEM TROUBLE indicator on LED annunciator module.
6. Activation of yellow OUTPUT indicator(s) on LED annunciator module of any output circuit(s) which have been described as TROUBLE BELL.
7. The remote annunciator RA-4410RC will not function if problem exists on nonresettable 24VDC.

**To Silence The Buzzer Or Outputs That Have Been Described As Trouble Or Supervisory Bell**

Press the scroll up or scroll down buttons. Once all events in the trouble or supervisory queue have been viewed, the buzzer and appropriate output will silence. The applicable system TROUBLE or SUPERVISORY LED will change from flashing to steady.

**NOTE:** Any continuous trouble conditions that have been silenced automatically resound 24 hours after the first trouble condition was silenced.

**TO SILENCE A SIGNALING APPLIANCE**

Press the SIGNAL SILENCE button. All silencable outputs will de-activate. A trouble condition will be created and the amber Alarm Silenced LED will light.

** WARNING**

Where audible and/or visual indicators are being used as an evacuation signal, do not silence an alarm condition without investigating and determining that an emergency condition does not exist.

- NOTES:**
1. Alarms initiated from zones that are in the waterflow mode cannot be silenced. The panel must be reset to silence audible alarm devices.
  2. If silenceable waterflow indication is desired it must be programmed as conventional alarm and annunciated on the zone identification portion of the LCD.

**To Reset an Alarm or Supervisory Condition**

1. Determine the cause of the alarm condition and if necessary remove the cause.
2. Press the reset button.

**To Reset A Trouble Condition**

1. Determine the cause of the trouble condition and remove the cause.
2. This circuit is self-restoring. When all trouble conditions are removed all indications will return to normal.

**NOTE:** When an initiating device zone is operated in a Class A (Style D) mode any trouble condition will require manual operation of the reset switch to restore the panel to normal after the fault has been corrected.

**Lamp Test**

When the panel is in a Normal Condition, pushing the top two buttons will illuminate all of the LED's and display for approximately one second.



## REMOTE ANNUNCIATOR MODEL RA-4410RC OPERATION

Red LED's: Initiating Device Circuits Active (4)  
 Notification/Release Circuits Active (4)  
 Common Alarm (1)

Green LED's: AC Power

Yellow LED's: Initiating Device Circuits troubles (4)  
 Output Circuit Troubles (4)  
 Supervisory Initiating Zone (4)  
 Supervisory Bell Output Active (4)  
 (1) each: Supervisory 1, Supervisory 2, Power  
 Trouble, Supervisory Trouble, System Trouble,  
 Ground Fault, Pre-Discharge/Discharging, Alarm Silenced

RA-4410RC

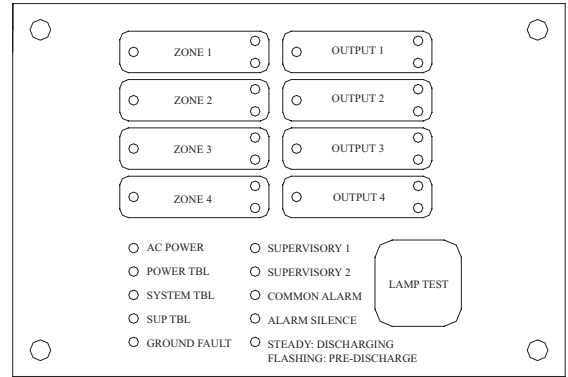

DWG# 3550-17VKG

### Basic Operation

The appropriate LED flashes to indicate a change of status on the panel. A trouble or supervisory condition will flash the appropriate Yellow LED indicating the location of the condition. If any outputs are programmed as TROUBLE or SUPERVISORY BELL, that Yellow output LED will flash indicating the output is activated. Pressing the BUZZER SILENCE button on the panel changes the flashing zone Amber LED to steady on and turns the flashing Yellow output LED off. An alarm or low air alarm condition will flash a Red LED indicating the zone in alarm and any outputs mapped to that zone that have activated. Pressing the SIGNAL SILENCE button changes the flashing Red Zone LED to steady on and the flashing Red Output LED mapped to that zone off unless the output is programmed as RELEASE. In addition, the Yellow ALARM/ SILENCE LED will light.

Any zone programmed as WATERFLOW is considered non-silenceable so the SIGNAL and BUZZER SILENCE buttons will have no effect on the flashing zone and output LED's. A buzzer on the annunciator sounds for any trouble condition. When the panel has a trouble or supervisory condition, pressing the SILENCE/LAMP TEST button silences the condition at the panel and all annunciators. When the panel is in a normal state, pressing the SILENCE/LAMP TEST button can be used to test the LED's.

The release panel supervises and communicates with the annunciator via separate connections for the RS-485 communication and 24VDC power requirements of the RA-4410RC. Separate cables should be used for power and communication. Shielded cable shall be used for the communication line. Up to three annunciators can be connected to one panel. A rotary switch is provided on the panel to indicate how many annunciators are connected. Another rotary switch is on the annunciator to set the address. The annunciators must be addressed consecutively. See page 19 for wiring information. Refer to bulletin #8840024 for installation instructions and maximum wire run.

### INSTALLATION INSTRUCTIONS

Read the entire manual before attempting to install this panel.

#### NOTICE

This panel wiring should be installed and maintained in accordance with section 760 (Fire Protection Signaling Systems) and all other applicable sections of the National Electrical Code, all other applicable NFPA Code and Standards, local code and the authority having jurisdiction. Review the circuit parameters listed below before installing the panel.

#### NOTICE

All wiring terminals support 14 to 22 AWG wire sizes. 18 AWG stranded or solid copper wire, (or wire size rated for the current carrying capacity of the input and output circuit application), with 300V, 85°C insulation is recommended.

**WIRE CHECKOUT**

With all initiating devices and notification appliances installed and with the EOLR's in place, check the wires with an ohmmeter. Meter readings outside of the following will prevent normal operation.

From any wire to ground – less than 100K ohms.

Across the 2 wires on each Initiating zone – between 1.8K ohms and 5.4K ohms.

Across the 2 wires on each notification circuit – between 1.8K ohms and 23.9K ohms.

**Mounting Instructions**

1. The unit should be mounted in a convenient location, approximately 5 ft. from the floor where it will be accessible for testing and servicing.

 <b>WARNING</b>
Removal of this false front exposes electrical components at potentially hazardous voltages and should be performed by qualified personnel only.

2. The main circuit board module should be removed before attempting to mount the cabinet. Disconnect the AC power from TB201. To remove the module, remove the two screws holding the chassis to the cabinet. Lift the module upwards, approximately 1/2", in order to clear the cross-beam of the cabinet on which the module rests. Remove the module and set aside.
3. Install all required conduits, external wiring and devices and make all connections that are external to the panel. Replace the module. With the AC power still turned off at the circuit breaker panel, connect the AC hot, neutral and ground wires to the terminal block TB201 as shown on the connection drawing. (See connection drawings on page 19)
4. Connect all the other wiring to the terminals as shown in the connection drawings. Turn the AC power on and connect the standby batteries with the cable provided, polarity must be observed.
5. Replace false front panel and secure with mounting screws.
6. The operation of the complete system should be verified as outlined in the test procedure section.

**VFR-400 False Front Removal/Assembly Drawing**

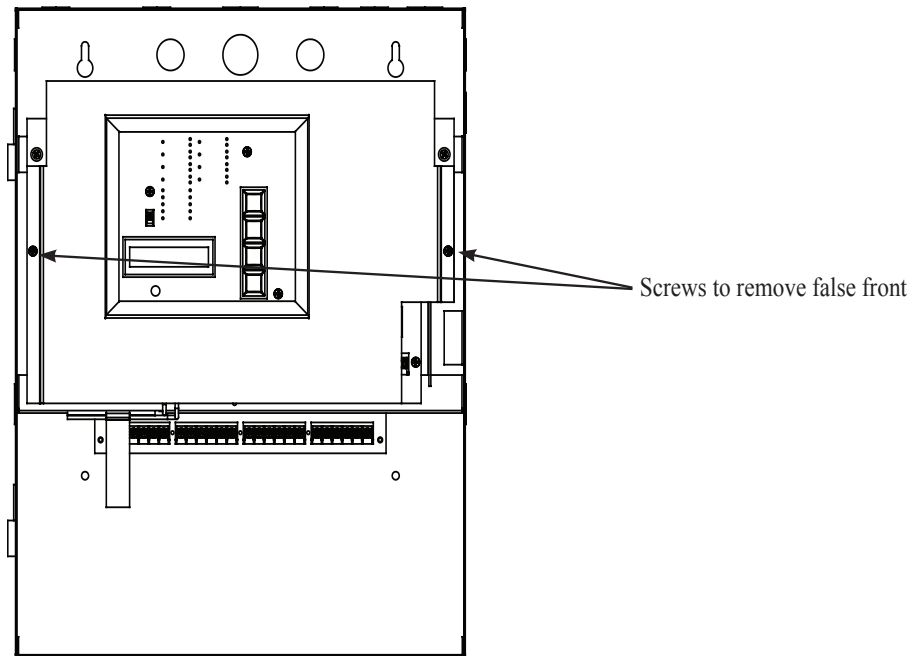

DWG# 3550-15

**Inactive Circuits**

All inactive initiating device circuits must have the end-of-line resistor on the panel terminal.

**Operating Instructions Form**

Fill in the name, address, and telephone number of the servicing agency on the appropriate instruction sheet. Frame and place this sheet adjacent to control panel at eye level.

**BATTERY SIZE CALCULATIONS**

To use Calculation Table:

1. List in column #1 all devices used in the system, include all modules, bells, horns, door holders, and smoke detectors (see table #1 or manufacturers specifications).
2. List in column #2 the quantity of each device.
3. List in column #3 the standby current of each device (exclude all signal indicating devices).
4. List in column #5 the alarm current of each device.
5. For each line, multiply the figure in column #2 by the figure in column #3 and enter the product in column #4. Then multiply the figure in column #2 by the figure in column #5 and enter the product in column #6.
6. Add the figures in columns #3 and #6, enter the sums in the appropriate Total mA box.
7. Convert these figures from milliamperes to amperes by multiplying by 0.001, enter the product in the appropriate Total A box.
8. Multiply the standby total amperes by required time in hours from table 2.
9. Divide the alarm total amperes by 12 (5 mins.).
10. Add the standby AH and the alarm AH and divide this sum by 0.85 (efficiency factor). Select a battery that has an AH rating above this figure but not less than 6.5AH.

**BATTERY SIZE REQUIREMENTS AND MAINTENANCE**

Charging Voltage: 27VDC Nominal

Maximum Charging Current: .5A

These panels require a 24 volt sealed lead acid battery for proper operation. 24 hours of standby power is required for Local Systems and Central Station (NFPA-72).

The chart below will assist you in selecting the proper size battery: (Does not include LED Annunciator)

No. of Smoke Detectors	No. of Bells (100mA each)	Auxiliary Power Requirements	Standby Hours Required	Battery Size/Part No. (2 Req.)
0-100	0-10	0-25mA	24	8AH/BT 80
0-100	0-10	0mA	90	12AH/BT 120
0-100	0-10	0-30mA	90	18AH/BT 180

**NOTICE**

Maximum allowed battery size for UL Listings is 12AH. FM and others may require more than 24 hours of standby time and may use larger batteries. Batteries rated above 18AH require a separate battery cabinet (Potter Model BC-2). Mark the purchase date on the batteries. Test the batteries at least semi annually according to the battery test methods in NFPA72 or the battery manufacturers instructions. Replace the batteries if they either fail the test or after four years of use. The VFR-400 is capable of charging 24 AH batteries, (FM Applications only).

**Maintenance**

Test batteries per local and national standards. At a minimum replace batteries every four (4) years or sooner depending on test results. The date of purchase shall be marked on all batteries.

### CONNECTION PROCEDURE FOR BATTERY CHARGING CURRENT AND VOLTAGE

1. To measure the battery charging voltage:  
Place a voltmeter across the battery terminals as shown in FIG. 4
2. To measure the battery charging current:  
Place a current meter in series with the battery terminals as shown in FIG. 5.

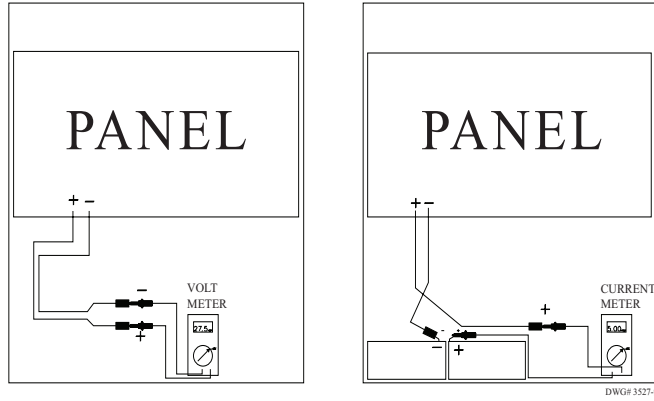

### CONNECTION DRAWING FOR CENTRAL STATION AND REMOTE STATION OPERATION VFR-400/UL 9th Edition Listed Digital Alarm Communicator Transmitter (DACT)

\*\* UL864 9th Edition listed stand alone DACT connected as shown and installed in the same room within 20 feet of the VFR-400 and with interconnecting wiring in conduit.

The VFR-400 and DACT shall be installed in the same room within 20 feet of each other and the interconnecting wires shall be in conduit.

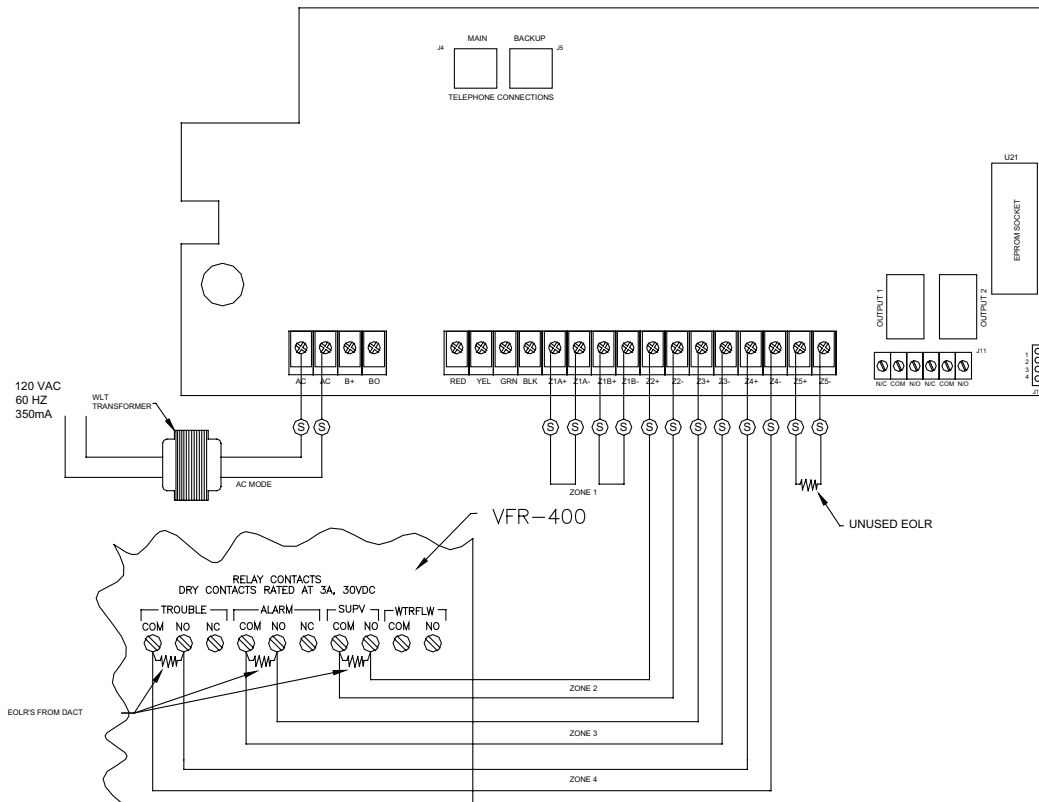

**TABLE 1 CURRENT REQUIREMENTS**

Module/Device	Standby mA*	Alarm mA**
VFR-400	121	274
RA-4410RC	11	13

\*Add 23 mA plus current requirement of all devices connected for each output programmed as Trouble Bell  
 \*\*Includes one zone short circuit current.

**TABLE 2 SECONDARY POWER SUPPLY REQUIREMENTS**



Service Use	Standby Time	Alarm Time
NFPA 72 • Central Station (PPU) • Local	24 hrs. 24 hrs.	5 mins. 5 mins.
FMRC 1011 and 1012, Deluge and Pre-action Systems Where requested by FM or others. 90 Hours is not a UL requirement.	90 hrs.	10 mins.

**CALCULATION TABLE**

1	2	3	4	5	6
Module/Device	Quantity	Standby mA Per Unit	Total Standby Current	Alarm mA Per Unit	Total Alarm Current
		Total mA		Total mA	
		Convert to A	x 0.001	Convert to A	x 0.001
		Total A		Total A	
Multiply by hours from table 2			x ____	5 min/12 or 10 min/6	÷ ____
		Total Standby AH		Total Alarm AH	
				+ Total Standby AH	
				Total AH	
				Efficiency Factor	÷ 0.85
				Required AH	

Use a battery with a higher AH rating than Required AH

**WIRE ROUTING FOR VFR-400**

-  Power Inputs
-  Battery Leads
-  Using The Cable Clamps Provided, Route All Other Wiring Away From Power Input Wiring.

**NOTICE**

All field installed wiring connected to this panel must maintain a spacing of 1/4" between all electric light, power, class 1 or non-power limited fire protective signaling conductors.

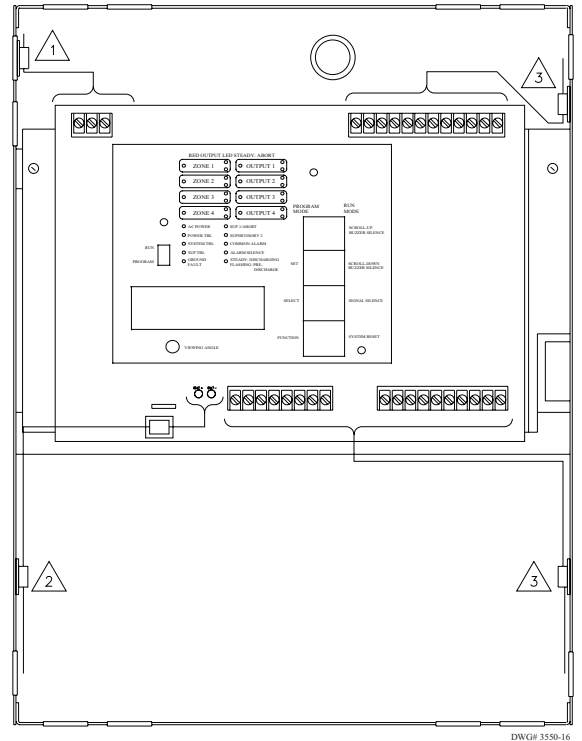

**NOTICE**

**NEC Section 760-54. Installation of Conductors and Equipment**

- (a) Separation from Electric Light, Power, Class 1, and NPLFA Circuit Conductors.
- (1) In Cables, Compartments, Enclosures, Outlet Boxes, or Raceways. Power-limited circuit conductors shall not be placed in any cable, compartment, enclosure, outlet box, raceway, or similar fitting containing conductors of electric light, power, Class 1, or nonpower-limited fire alarm circuit conductors.

Exception No. 1: Where the conductors of electric light, power, Class 1, or nonpower-limited fire alarm circuit conductors are separated by a barrier from the power-limited fire alarm circuits. In enclosures, power-limited fire alarm circuits shall be permitted to be installed in a raceway within the enclosure to separate them from Class 1, electric light, power, and nonpower-limited fire alarm circuits.

Exception No. 2: Conductors in compartments, enclosures, device boxes, outlet boxes, or similar fittings, where electric light, power, Class 1, or nonpower-limited fire alarm circuit conductors are introduced solely to connect to the equipment connected to power-limited circuits to which the other conductors are connected, and

- a. The electric light, power, Class 1, and nonpower-limited fire alarm circuit conductors are routed to maintain a minimum of 0.25 in. (6,35mm) separation from the conductors and cables of power-limited fire alarm circuits, or
- b. The circuit conductors operate at 150 volts or less to ground and also comply with one of the following:

1. The fire alarm power-limited circuits are installed using Types FPL, FPLR, FPLP or permitted substitute cables, provided these power-limited cable conductors extending beyond the jacket are separated by a minimum of 0.25 in. (6,35mm) or by a nonconductive sleeve or nonconductive barrier from all other conductors, or
2. The fire alarm power-limited circuit conductors are installed as nonpower-limited fire alarm circuits in accordance with Section 760-25.

Exception No. 3: Conductors entering compartments, enclosures, device boxes, outlet boxes, or similar fittings, where electric light, power, Class 1, or nonpower-limited fire alarm circuit conductors are introduced solely to connect to the equipment connected to power-limited fire alarm circuits or to other circuits controlled by the fire alarm system to which the other conductors in the enclosure are connected. If the conductors must enter an enclosure that is provided with a single opening, they shall be permitted to enter through a single fitting (such as a tee) provided the conductors are separated from the conductors of the other circuits by a continuous and firmly fixed nonconductor, such as flexible tubing.

### Typical Firecycle Wiring

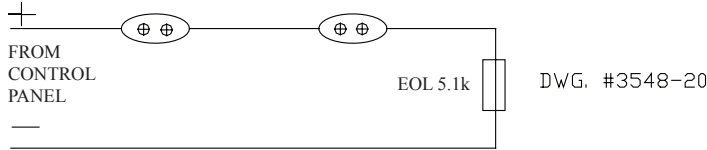

### Typical 2 Wire Detector Connection Drawing

Base wiring for Potter models IS-24 Ionization Detectors and PS-24 Photoelectric Detectors.

### Typical Style B (Class B) Wiring Using SB-46 Base

(These bases can be used in style B or Style D wiring)

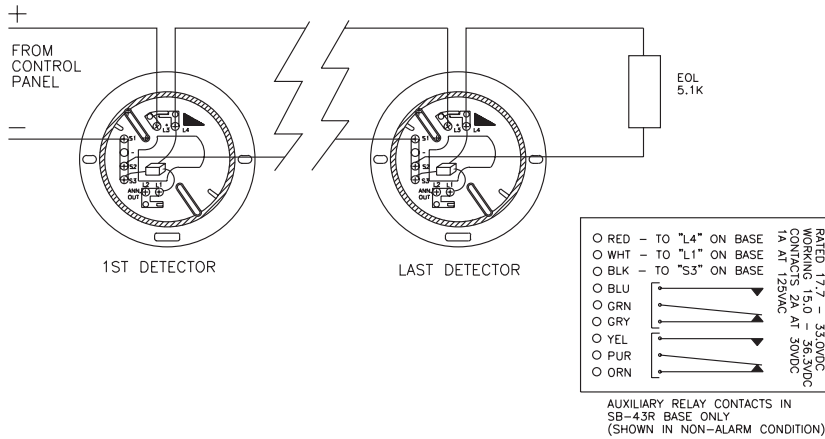

### Typical Style D (Class A) Wiring

(These bases can be used in style B or style D wiring)

**NOTE:** The 6" diameter bases will mount on a 3" or 4" octagon box or a 4" square box.

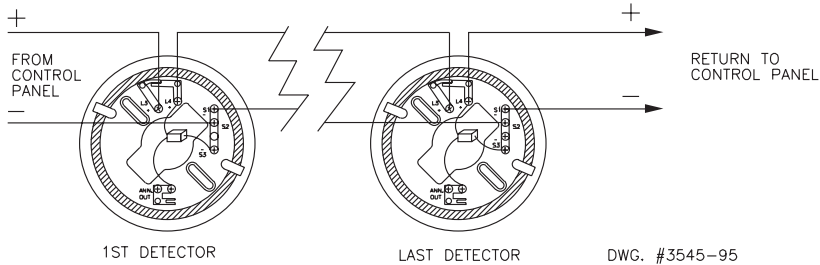

### Typical 4-Wire Wiring

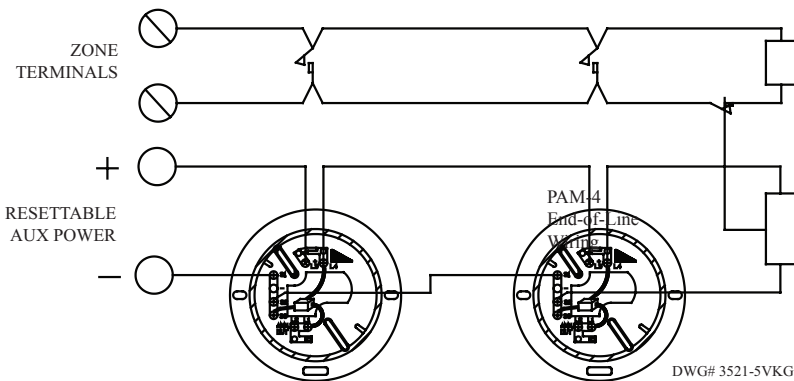





**Test Procedure**

The system should be inspected, tested, and maintained in accordance with NFPA-72 National Fire Alarm Code, Chapter 10 and any other requirements of the local authority having jurisdiction.

**Test Procedure (Canada)**

The system should be inspected, tested, and maintained in accordance with ULC Standard CAN/ULC-S536 and any other requirements of the local authority having jurisdiction.

**CAUTION**

Testing should be done as a minimum as described below:

1. Notify the fire department or other receiving station if alarm, supervisory and/or trouble signals are transmitted.
2. Notify the proper building personnel so that audible and/or visual signals can be ignored.
3. If the release panel is monitored by a building fire alarm panel, take appropriate action to eliminate any unwanted events.
4. Momentarily open each of the following circuits.
  - Each initiating device zone
  - Supervisory circuit
  - Indicating Appliance/Releasing circuit - observe that this results in a trouble condition and all indicators operate as described in the appropriate preceding section for the particular circuit that is faulted.
5. Move the PROGRAM switch down. The LCD should respond: "LOOK AT HISTORY?". Press the FUNCTION button until the display reads PASSWORD=000. Enter password if changed from factory or press the SET button three times. Press the FUNCTION (bottom) button until the LCD reads "SYSTEM MODE: NORMAL". Press the SELECT button. The LCD will read "SYSTEM MODE: ONE MAN WALKTEST". Press the SET button then move the PROGRAM switch up. The panel will respond with "ONE MAN WALKTEST" and the time. The trouble LED will light. Any output described as "RELEASING" will automatically be disabled.

**WARNING**

Failure to enter the walktest mode and subsequent operation of initiating zones may result in a release.

**NOTE:** The optional RCDS-1, Release Circuit Disconnect Switch, can be used to provide a physical means of disconnecting the release circuit in compliance with NFPA 72, 2007, 6.12.5.2

**After 30 minutes of no activity in the walk test mode the panel automatically reverts to normal operation.**

6. Operate each initiating device on all zones. All audible and visual alarm devices should operate for about 3 seconds. Then the system will automatically reset allowing the user to go to the next initiating device.
7. Operate each initiating device on the supervisory circuit. Observe that all the indications described in the section on supervisory conditions occur.
8. Move the PROGRAM switch down again. The LCD should respond: "LOOK AT HISTORY?". Press the FUNCTION button until the display reads PASSWORD=000. Enter password if changed from factory or press the SET button three times. Press the FUNCTION (bottom) button until the LCD reads: "SYSTEM MODE: ONE MAN WALKTEST". Press the SELECT (middle) button. The LCD will read: "SYSTEM MODE: NORMAL". Press the SET (top) button then restore the PROGRAM switch to the up position. The LCD will show the normal banner message.
9. All audible and visual indicators should be off.
10. Notify all building, fire department, and/or other receiving station personnel that the test has concluded.

**PROGRAMMING MODE INSTRUCTIONS**

To use the Programming Mode push the program switch down (see drawing below).

**PANEL VISUAL DISPLAY**

As a general rule, the following applies on the Programming Mode buttons:

The top button (SET) sets the message on the display into the memory.

The middle button (SELECT) scrolls through the selections available for the function displayed.

The bottom button (FUNCTION) allows the user to skip the function without changing the program.

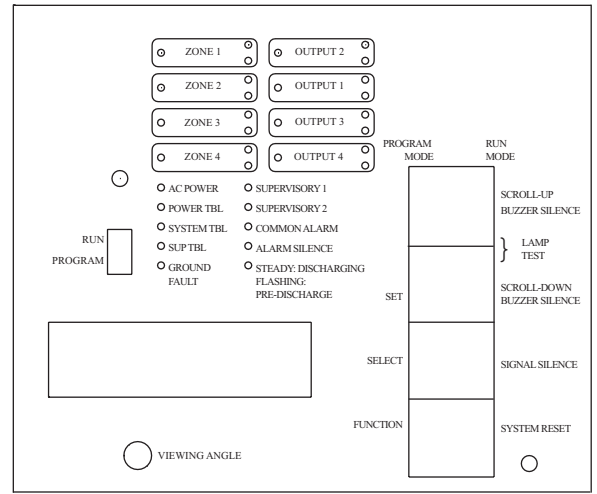

To program, push the Program Switch down.

There is no capability to back up screens in the program mode. If a mistake was made during programming, move the program switch back up, then move it down and start from the beginning.

To exit the program mode at any time, move the Program Switch up.

When the programming switch is down (see Panel Visual Display) the following will appear in the display window:

L	O	O	K		A	T									
H	I	S	T	O	R	Y	?								

**History**

To examine the HISTORY press the top button, the display window will show the time and date of the last event or action. To skip to the next function or to exit history, press the FUNCTION (bottom) button.

**SET**  Press the SET button to discover the time and date of the last event or action and to scroll forward.

**SELECT**  To scroll back, press the SELECT button.

**FUNCTION**  To exit or skip HISTORY, press the bottom button.

S	E	T		T	I	M	E	?							

**Date/Time**

**SELECT**  To change the time, press the SELECT button.

**FUNCTION**  To exit to the next function, press the bottom button.

If the middle button is pushed, the date and time will appear in the display window:

					0	1	/	0	5	/	2	0	0	7	

The date is shown at the top and the time at the bottom of the display window. "MINUTES" indicates that the user can now change the minutes.

**SET**  Pressing the SET button will decrease the minutes

**SELECT**  Pressing the SELECT button will increase the minutes.

**FUNCTION**  When finished setting the minutes, Press the bottom button. The minutes will change to hours.

Continue this process and change the DAY, MONTH and YEAR. When you have finished changing the year, press the FUNCTION (bottom) button. A display similar to the following will appear:

P	A	S	S	W	O	R	D	=	0	0	0				
									^						

**Password**

This display prevents unauthorized programming of the panel by requiring the user to enter the proper password. To select the appropriate number for the space indicated by the ^ symbol, press the SELECT button. When the proper number is displayed press the SET button to set the number and move to the next space. If the wrong password is entered, the panel will display "Push Programming Switch Up". All panels are shipped from the factory with a password of 000. If the password is lost contact Viking.

**SET**  After selecting the desired number, press the SET button to set and move to the next number.

**SELECT**  Press the SELECT button to scroll through the numbers.

**FUNCTION**  Pressing the bottom button will have no effect.

After entering the correct password, a display similar to the following will appear:

I	N	I	T		Z	O	N	E		#	1				
E	N	A	B	L	E	D									

**Zone Disabled/Enabled**

This display allows the user to ENABLE or DISABLE Initiating zones. This display window shows that initiating ZONE #1 is enabled. To toggle from ENABLED to DISABLED or visa versa, press the SELECT button.

**SET**  After selecting ENABLED or DISABLED, press the SET button to set and move to the next zone.

**SELECT**  Press the SELECT button to toggle between ENABLED or DISABLED.

**FUNCTION**  To skip to the next function, press the bottom button.

After selecting all four zones or pressing the FUNCTION (bottom) button, the following will appear in the display window:

O	U	T	P	U	T		#	1						
E	N	A	B	L	E	D								

**Output Enable/Disable**

This display allows the user to ENABLE or DISABLE any of the output circuits.

**SET**  After selecting ENABLED or DISABLED, press the SET button to set and move to the next output.

**SELECT**  Press the SELECT button to toggle between ENABLED or DISABLED.

**FUNCTION**  To skip to the next function, press the bottom button.

After selecting all four outputs or pressing the FUNCTION (bottom) button, the following will appear in the display window:

**NOTICE**

Disabling any input or outputs will create a trouble condition on the panel.  
Disabling a releasing circuit will create a supervisory condition.

S	Y	S	T	E	M		M	O	D	E	:			
N	O	R	M	A	L									

**One Man Walktest**

This display allows the user to select system mode NORMAL or ONE MAN WALKTEST by pressing the SELECT button to toggle back and forth from NORMAL to ONE MAN WALKTEST. When the desired mode is displayed, press the SET button. If ONE MAN WALKTEST is selected for test purposes, the display must be restored to the NORMAL setting after the test is completed by toggling to it using the SELECT button.

**WARNING**  
After 30 minutes of no activity the panel automatically reverts to normal.

**SET**  After selecting NORMAL or ONE MAN WALKTEST, press the SET button to set that mode.

**SELECT**  Press the SELECT button to toggle between NORMAL and CROSS ZONED.

**FUNCTION**  Press the bottom button to skip to the next function.

After selecting the operating mode or pressing the FUNCTION button a display similar to the following will appear in the display window:

P	R	O	G	R	A	M		#	1					

**VFR-400 STANDARD PROGRAM INFORMATION**

The VFR-400 has 16 standard programs which are detailed in the following pages. Selecting one of these programs will automatically program every function of the panel except the custom banner and zone message functions.

**NOTES:**

The release discharge time is continuous for all programs not employing the Firecycle feature. The default soak timer for the Firecycle feature is continuous.

The following is an explanation of how the various programs operate and information about the types of devices that are to be connected to the input and output zones. If none of the standard programs are acceptable for the installation required, select the custom program #0 then press the SET button. This will allow the user to custom program the panel. Turn to page 70 for custom program information.



	Type	Description
<b>Alarm Zones</b>	Detection	Smoke Detectors, Spot Type Heat Detectors
	Waterflow	PS10 Pressure Switch
	Linear Heat	Cable Type Heat Detectors
	Manual Release	Pull Stations
	Firecycle	Viking normally closed heat detectors
<b>Supervisory Zones</b>	Supervisory	Valve Tamper, Low Air, High Air, Room Temperature
	Low Air supervisory	Low Air Switch
	High Air	High Air Switch
	Tamper	Valve Tamper Switch
	Low Air Alarm *	PS10, PS40

\* Not available on Supervisory Zones Sup 1 or Sup 2

Outputs	Alarm	24VDC Bells, Horns, Strobes, to indicate an alarm condition.
	Release	Solenoid Valve, Squib, Releasing Mechanism
	Supervisory	24VDC Bells, Horns, Strobes, to indicate a supervisory condition.
	Trouble	24VDC Bells, Horns, Strobes, to indicate a trouble condition.

To program the VFR-400 to operate with one of the following 12 standard programs:

1. Press SELECT button to scroll to the program number (#1 thru #12) you desire.
2. Press SET button.
3. Turn to page 72 to program the banner message and to finish programming the panel.

<b>SET</b>		After selecting the proper program number, press the SET button to set the program and move to the next function.
<b>SELECT</b>		Press the SELECT button to scroll through the programs.
<b>FUNCTION</b>		Press the bottom button to skip to the next function.

**NOTICE**

After selecting the desired program number with the middle button, SET **must** be pressed to set the program. When the Firecycle programs (6-9) are selected, only outputs #3 and #4 can be selected as releasing.

If the Firecycle feature is used, Firecycle heat detectors must be connected to Zone 1. Zone 1 follows the status of the Firecycle detector. When the detector resets, a soak timer is initiated. The default soak timer is continuous. The soak timer is user selectable to 30, 60, or 90 seconds or 2 - 20 minutes in 1 minute increments.

**WIRING DIAGRAM PROGRAMS**

<b>PROGRAM #1</b>						
For One Sprinkler System						
Viking Sprinkler System Types	2 Release Zones, Waterflow Zone, & Manual Release Zone	1. Single Interlocked Preaction System with Electric Release				
		2. Deluge System with Electric Release				
		3. Non-Interlocked Preaction System with Electric Release				
		4. Double Interlocked Preaction System with Electric/Pneumatic Release				
OUTPUTS (Indicating Circuits)	ZONES (Initiating Circuits)					
	SUP 1	SUP 2	#1	#2	#3	#4
	Low Air Supervisory Zone	Valve Tamper Supervisory Zone	Conventional Detection Zone	Conventional Detection Zone	Waterflow Zone	Manual Release Zone
#1 General Alarm			X	X	X	X
#2 Waterflow					X	
#3 Release Solenoid			X	X		X
#4 Supervisory Bell	X	X				
OPERATION DESCRIPTION						
Inputs:	2 Conventional Detection zones, 1 Waterflow zone, 1 Manual Release zone, 2 Supervisory zones					
Outputs:	1 General Alarm, 1 Waterflow Alarm, 1 Solenoid Release, 1 Supervisory Bell					
Operation:	Activation of Conventional Detection zone #1 or #2 or Manual Release zone #4 will activate output #3 (Release Solenoid) and output #1 (General Alarm)					
	Activation of Waterflow zone #3 will activate output #2 (Waterflow) and output #1 (General Alarm)					
	Activation of Low Air Supervisory zone #1 or Valve Tamper Supervisory zone #2 will operate output #4 (Supervisory Bell).					

**NOTES:**

1. Connect EOL Diode assembly IN SERIES as shown with Solenoid on output #3 (Release Solenoid). Black wire to negative terminal on panel and Red wire through Solenoid to positive terminal on panel.
2. Polarity is shown on indicating circuits in an activated (in alarm) condition.
3. Leave EOLR (provided) on all unused circuits.
4. See the instruction manual for circuit information, panel limits, and battery sizing.
5. For wire routing instructions through the releasing panel, see Note 3 on page 17 of the instruction manual.
6. See instruction manual for proper programming.
7. See instruction manual for list of compatible smoke detectors.
8. See specific system type data page for proper pressure switch settings.

**PROGRAM #1**

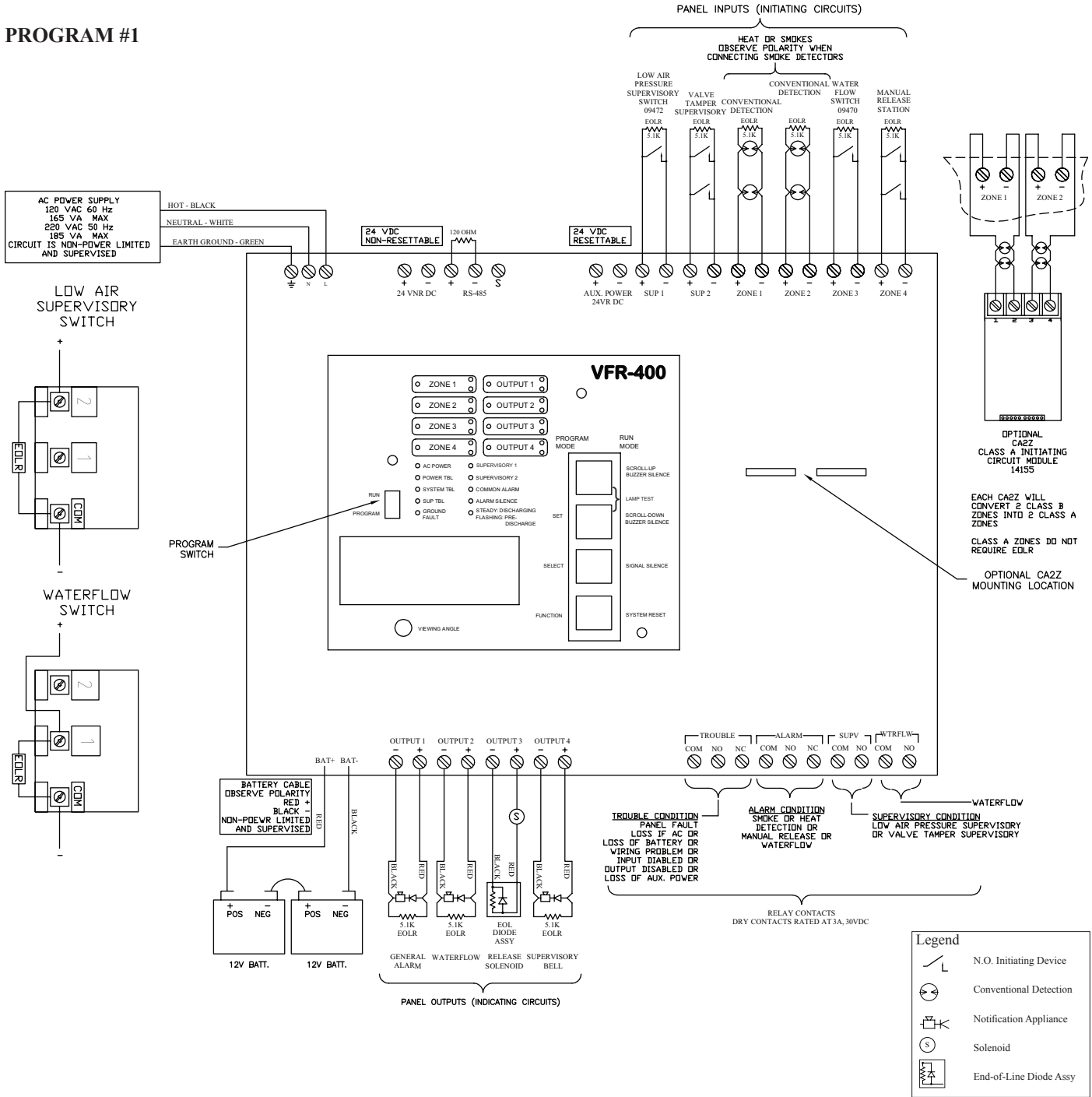

1. Run field wiring and ensure connections are proper by metering wires. Resistance reading should be 5.1K ohms with end-of-line resistor (EOLR) at last device. The end-of-line resistor is located on the mother board. Remove as needed. Leave factory installed EOLR on all unused circuits.
2. Connect one circuit at a time and apply AC power.
3. Connect batteries to the panel.
4. Once last connection is made, move Program switch down.
5. Press the FUNCTION (bottom) button until the display reads "PASSWORD = 000".
6. To enter a password, press the SELECT button until the proper number is displayed above the ^ symbol, then press the SET button to move to the next digit. After entering the third number the display will change. (All panels are shipped with a 000 password.)
7. Press the FUNCTION (bottom) button until the display reads "PROGRAM #1".
8. Press the SELECT button until the display reads "PROGRAM #1".
9. Press the SET button.
10. The panel is completely programmed except for the custom banner and zone messages. Move the program switch back up.

<b>PROGRAM #2</b>						
For Two Sprinkler Systems Operating Independantly From Each Other						
Viking Sprinkler System Types	2 Split Release Zones and 2 Waterflow Zones	1. Single Interlocked Preaction System with Electric Release				
		2. Deluge System with Electric Release				
		3. Non-Interlocked Preaction System with Electric Release				
		4. Double Interlocked Preaction System with Electric/Pneumatic Release				
OUTPUTS (Indicating Circuits)	ZONES (Initiating Circuits)					
	SUP 1	SUP 2	#1	#2	#3	#4
	Valve Tamper Supervisory Zone for Systems 1 & 2	Low Air Supervisory Zone for Systems 1 & 2	Conventional Detection Zone for System 1	Conventional Detection Zone for System 2	Waterflow Zone for System 1	Waterflow Zone for System 2
#1 General Alarm			X	X	X	X
#2 Release Solenoid #1			X			
#3 Release Solenoid #2				X		
#4 Waterflow					X	X
OPERATION DESCRIPTION						
Inputs:	2 Conventional Detection zones, 2 Waterflow zones, 2 Supervisory zones					
Outputs:	1 General Alarm, 1 Waterflow Alarm, 2 Solenoid Release					
Operation:	Activation of Conventional Detection zone #1 will activate output #2 (Release Solenoid #1) and output #1 (General Alarm)					
	Activation of Conventional Detection zone #2 will activate output #3 (Release Solenoid #2) and output #1 (General Alarm)					
	Activation of Waterflow zone #3 or #4 will activate output #1 (General Alarm) and output #4 (Waterflow)					
	Activation of Valve Tamper Supervisory zone #1 or Low Air Supervisory zone #2 will operate supervisory trouble relay.					

**NOTES:**

1. Connect EOL Diode assembly IN SERIES as shown with Solenoid on output #2 (Release Solenoid) and output #3 (Release Solenoid). Black wire to negative terminal on panel and Red wire through Solenoid to positive terminal on panel.
2. Polarity is shown on indicating circuits in an activated (in alarm) condition.
3. Leave EOLR (provided) on all unused circuits.
4. See the instruction manual for circuit information, panel limits, and battery sizing.
5. For wire routing instructions through the releasing panel, see Note 3 on page 17 of the instruction manual.
6. See instruction manual for proper programming.
7. See instruction manual for list of compatible smoke detectors.
8. See specific system type data page for proper pressure switch settings.



**PROGRAM #2**

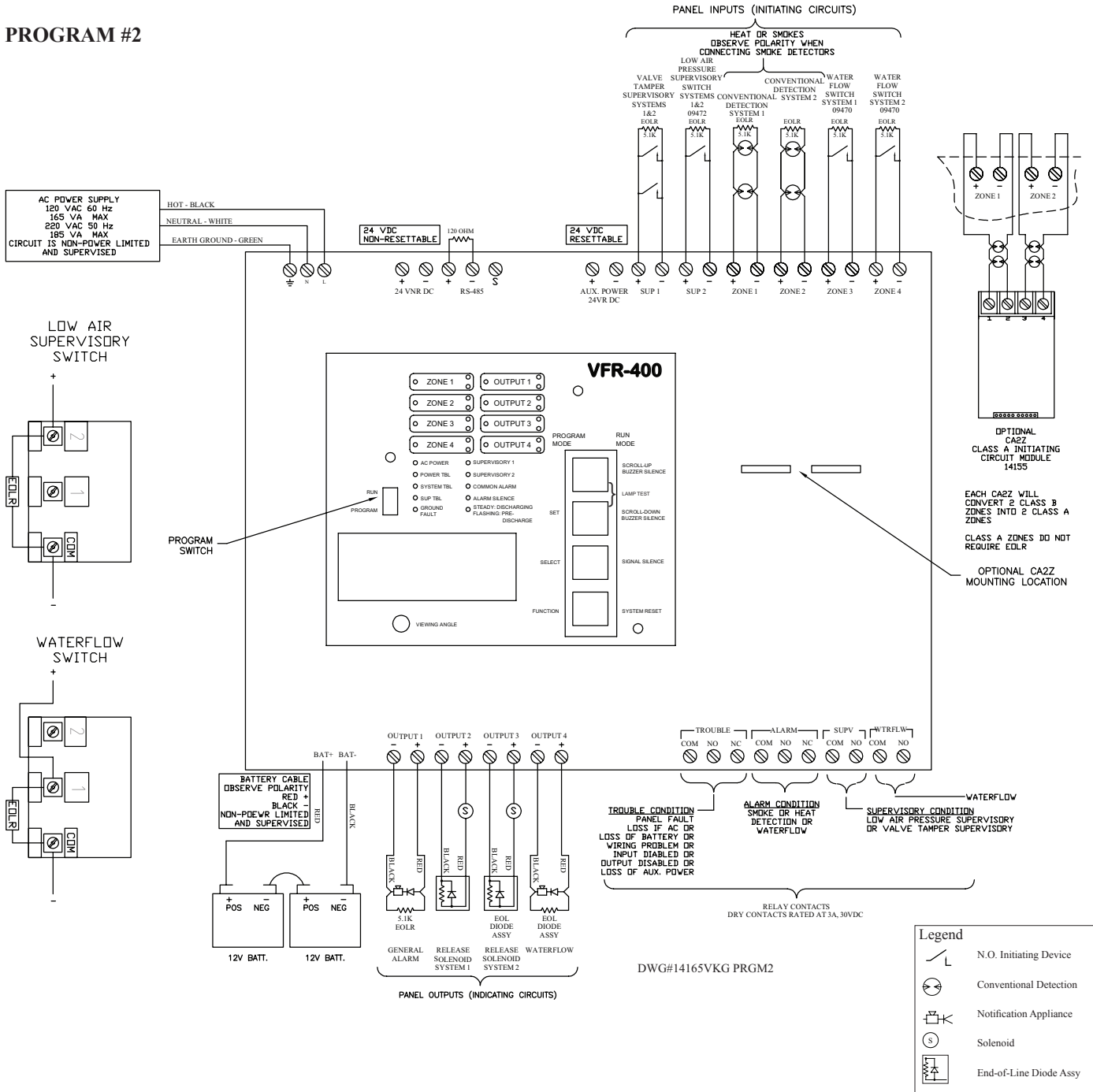

1. Run field wiring and ensure connections are proper by metering wires. Resistance reading should be 5.1K ohms with end-of-line resistor (EOLR) at last device. The end-of-line resistor is located on the mother board. Remove as needed. Leave factory installed EOLR on all unused circuits.
2. Connect one circuit at a time and apply AC power.
3. Connect batteries to the panel.
4. Once last connection is made, move Program switch down.
5. Press the FUNCTION (bottom) button until the display reads "PASSWORD = 000".
6. To enter a password, press the SELECT button until the proper number is displayed above the ^ symbol, then press the SET button to move to the next digit. After entering the third number the display will change. (All panels are shipped with a 000 password.)
7. Press the FUNCTION (bottom) button until the display reads "PROGRAM #2".
8. Press the SELECT button until the display reads "PROGRAM #2".
9. Press the SET button.
10. The panel is completely programmed except for the custom banner and zone messages. Move the program switch back up.

<b>PROGRAM #3</b>						
For One Sprinkler System						
Viking Sprinkler System Types	2 Cross Release zones, Waterflow zone, and Manual Release zone	1. Double Interlocked Preaction System with Electric/Pneu-Lectric Release				
OUTPUTS (Indicating Circuits)	ZONES (Initiating Circuits)					
	SUP 1	SUP 2	#1	#2	#3	#4
	Low Air Supervisory Zone	Valve Tamper Supervisory Zone	Conventional Detection Zone	Low Air Alarm Zone	Waterflow Zone	Manual Release Zone
#1 General Alarm			X		X	X
#2 Waterflow					X	
#3 Release Solenoid			X X	X X		X
#4 Supervisory Bell	X	X		X		
OPERATION DESCRIPTION						
Inputs:	1 Conventional Detection zone cross zoned with 1 Low Air Alarm zone, 1 Waterflow zone, 1 Manual Release zone, 2 Supervisory zones					
Outputs:	1 General Alarm, 1 Waterflow, 1 Release Solenoid, 1 Supervisory Bell					
Operation:	Simultaneous activation of both the Conventional Detection zone #1 and the Low Air Alarm zone #2 will activate output #3 (Release solenoid), output #1 (General alarm), and output #4 (Supervisory Bell)					
	Activation of Conventional Detection zone #1 will activate output #1 (General Alarm)					
	Activation of Low Air Alarm zone #2 will activate output #4 (Supervisory Bell)					
	Activation of Waterflow zone #3 will activate output #2 (Waterflow) and output #1 (General Alarm)					
	Activation of Manual Release zone #4 will activate output #3 (Release Solenoid) and output #1 (General Alarm)					
Activation of Low Air Supervisory zone #1 or Valve Tamper Supervisory zone #2 will operate output #4 (Supervisory Bell)						

XX = Cross zoned

**NOTES:**

1. Connect EOL Diode assembly IN SERIES as shown with Solenoid on output #3 (Release Solenoid). Black wire to negative terminal on panel and Red wire through Solenoid to positive terminal on panel.
2. Polarity is shown on indicating circuits in an activated (in alarm) condition.
3. Leave EOLR (provided) on all unused circuits.
4. See the instruction manual for circuit information, panel limits, and battery sizing.
5. For wire routing instructions through the releasing panel, see Note 3 on page 17 of the instruction manual.
6. See instruction manual for proper programming.
7. See instruction manual for list of compatible smoke detectors.
8. See specific system type data page for proper pressure switch settings.

**PROGRAM #3**

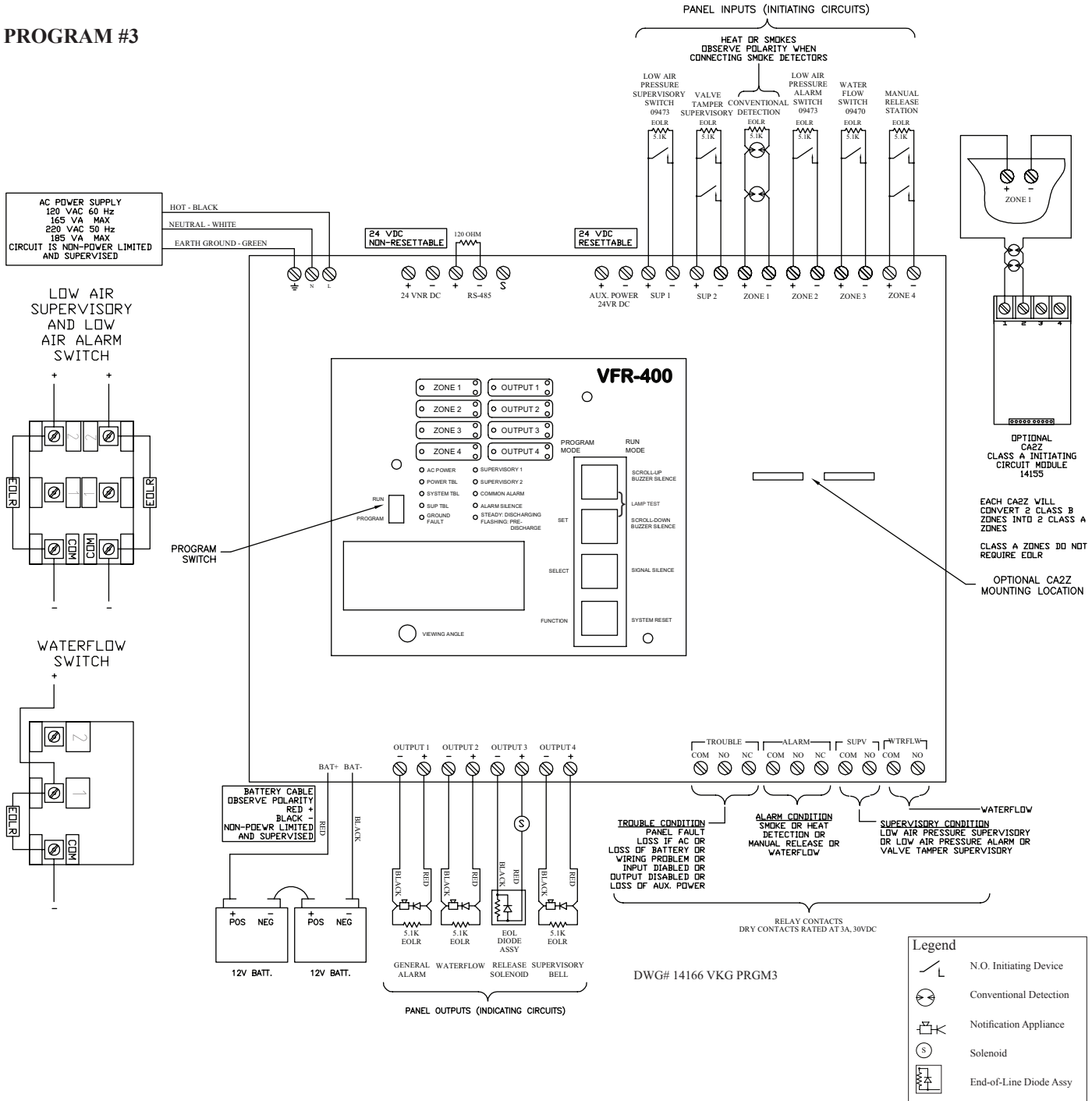

1. Run field wiring and ensure connections are proper by metering wires. Resistance reading should be 5.1K ohms with end-of-line resistor (EOLR) at last device. The end-of-line resistor is located on the mother board. Remove as needed. Leave factory installed EOLR on all unused circuits.
2. Connect one circuit at a time and apply AC power.
3. Connect batteries to the panel.
4. Once last connection is made, move Program switch down.
5. Press the FUNCTION (bottom) button until the display reads "PASSWORD = 000".
6. To enter a password, press the SELECT button until the proper number is displayed above the ^ symbol, then press the SET button to move to the next digit. After entering the third number the display will change. (All panels are shipped with a 000 password.)
7. Press the FUNCTION (bottom) button until the display reads "PROGRAM #3".
8. Press the SELECT button until the display reads "PROGRAM #3".
9. Press the SET button.
10. The panel is completely programmed except for the custom banner and zone messages. Move the program switch back up.

<b>PROGRAM #4</b>						
For Two Sprinkler Systems - Operating Simultaneously						
Viking Sprinkler System Types	2 Dual Release Zones, Waterflow Zone, and Dual Manual Release Zone	1. Single Interlocked Preaction System with Electric Release				
		2. Deluge System with Electric Release				
		3. Non-Interlocked Preaction System with Electric Release				
		4. Double Interlocked Preaction System with Electric/Pneumatic Release				
OUTPUTS (Indicating Circuits)	ZONES (Initiating Circuits)					
	SUP 1	SUP 2	#1	#2	#3	#4
	Valve Tamper Supervisory Zone for Systems 1 & 2	Low Air Supervisory Zone for Systems 1 & 2	Conventional Detection Zone for System 1	Conventional Detection Zone for System 2	Waterflow Zone	Manual Release Zone
#1 General Alarm			X	X	X	X
#2 Release Solenoid #1			X	X		X
#3 Release Solenoid #2			X	X		X
#4 Waterflow					X	
OPERATION DESCRIPTION						
Inputs:	2 Conventional Detection zones, 1 Waterflow zone, 1 Manual Release zone, 2 Supervisory zones					
Outputs:	1 General Alarm, 1 Waterflow, 2 Release Solenoids					
Operation:	Activation of Conventional Detection zone #1 or #2 or Manual Release zone will activate output #2 (Release Solenoid #1) and output #3 (Release Solenoid #2) and output #1 (General Alarm)					
	Activation of Waterflow zone #3 will activate output #4 (Waterflow) and output #1 (General Alarm)					
	Activation of Valve Tamper Supervisory zone #1 or Low Air Supervisory zone #2 will operate supervisory trouble relay					

**NOTES:**

1. Connect EOL Diode assembly IN SERIES as shown with Solenoid on output #2 (Release Solenoid) and output #3 (Release Solenoid). Black wire to negative terminal on panel and Red wire through Solenoid to positive terminal on panel.
2. Polarity is shown on indicating circuits in an activated (in alarm) condition.
3. Leave EOLR (provided) on all unused circuits.
4. See the instruction manual for circuit information, panel limits, and battery sizing.
5. For wire routing instructions through the releasing panel, see Note 3 on page 17 of the instruction manual.
6. See instruction manual for proper programming.
7. See instruction manual for list of compatible smoke detectors.
8. See specific system type data page for proper pressure switch settings.

**PROGRAM #4**

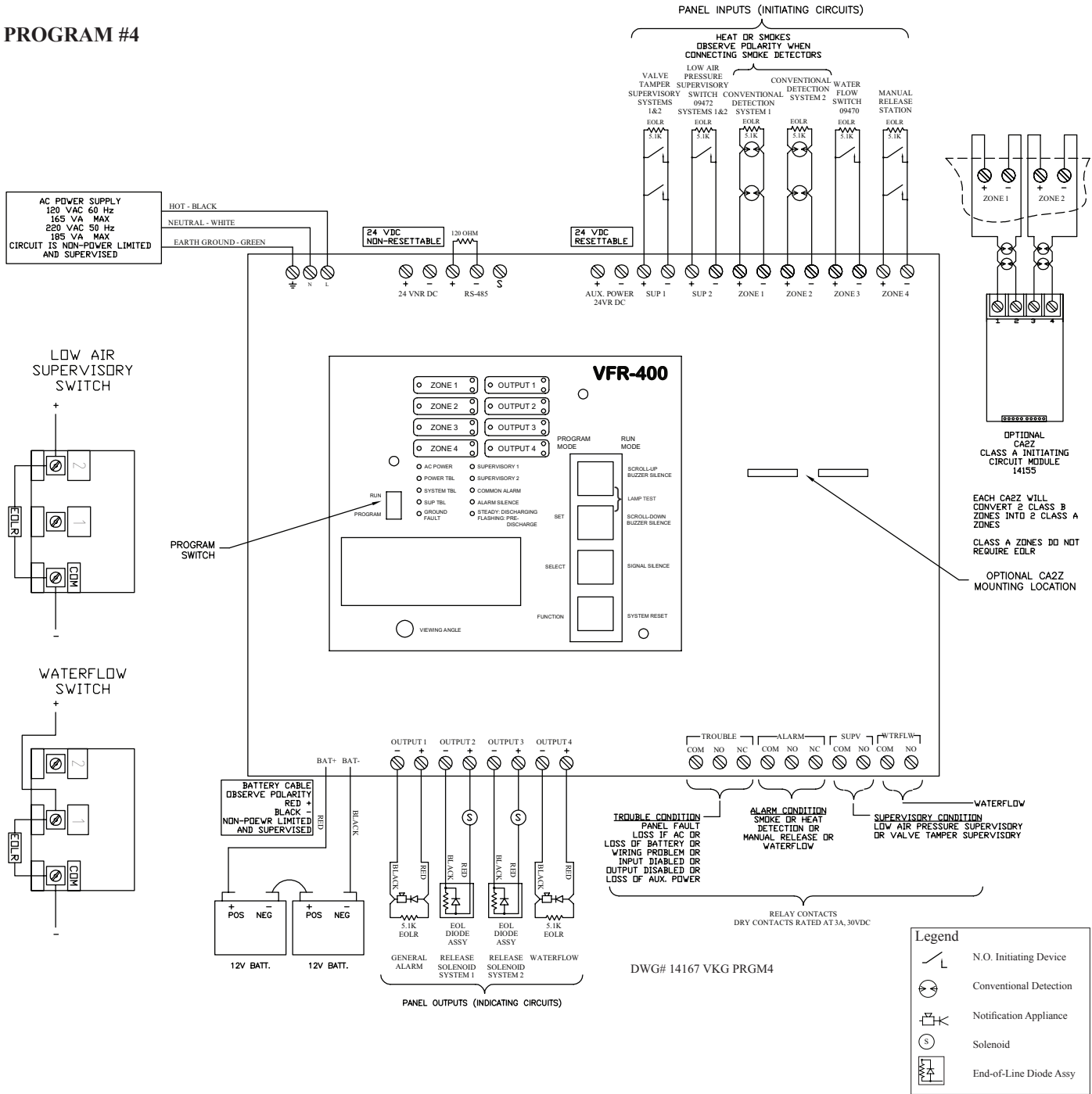

1. Run field wiring and ensure connections are proper by metering wires. Resistance reading should be 5.1K ohms with end-of-line resistor (EOLR) at last device. The end-of-line resistor is located on the mother board. Remove as needed. Leave factory installed EOLR on all unused circuits.
2. Connect one circuit at a time and apply AC power.
3. Connect batteries to the panel.
4. Once last connection is made, move Program switch down.
5. Press the FUNCTION (bottom) button until the display reads "PASSWORD = 000".
6. To enter a password, press the SELECT button until the proper number is displayed above the ^ symbol, then press the SET button to move to the next digit. After entering the third number the display will change. (All panels are shipped with a 000 password.)
7. Press the FUNCTION (bottom) button until the display reads "PROGRAM #4".
8. Press the SELECT button until the display reads "PROGRAM #4".
9. Press the SET button.
10. The panel is completely programmed except for the custom banner and zone messages. Move the program switch back up.

<b>PROGRAM #5</b>						
For One Sprinkler System- NYC Special						
Viking Sprinkler System Types	Release Zone and Manual Release Zone	1. Single Interlocked Preaction System with Electric Release				
		2. Deluge System with Electric Release				
		3. Non-Interlocked Preaction with Electric Release				
		4. Double Interlocked Preaction System with Electric/Pneumatic Release				
OUTPUTS (Indicating Circuits)	ZONES (Initiating Circuits)					
	SUP 1	SUP 2	#1	#2	#3	#4
	Valve Tamper Supervisory Zone	Low Air Supervisory Zone	Conventional Detection Zone	Low Air Alarm Zone	Waterflow Zone	Manual Release Zone
#1 General Alarm			X		X	X
#2 Supervisory Bell	X	X		X		
#3 Release Solenoid			X			X
#4 Trouble Bell						
OPERATION DESCRIPTION						
Inputs:	1 Conventional Detection zone, 1 Waterflow zone, 1 Low Air Alarm zone, 1 Manual Release zone, 2 Supervisory zones					
Outputs:	1 General Alarm, 1 Trouble Bell, 1 Release Solenoid, 1 Supervisory Bell					
Operation:	Activation of Conventional Detection zone #1 or Manual Release zone #4 will activate output #3 (Release Solenoid) and output #1 (General Alarm)					
	Activation of Waterflow zone #3 will activate output #1 (General Alarm)					
	Activation of Low Air Alarm zone #2 or Low Air Supervisory zone or Valve Tamper Supervisory zone will activate output #2 (Supervisory Bell)					
	A trouble condition, (low battery, wire short in outputs, loss AC, panel problem) will activate output #4 (Trouble Bell) and trouble relay					

**NOTES:**

1. Connect EOL Diode assembly IN SERIES as shown with Solenoid on output #2 (Release Solenoid) and output #3 (Release Solenoid). Black wire to negative terminal on panel and Red wire through Solenoid to positive terminal on panel.
2. Polarity is shown on indicating circuits in an activated (in alarm) condition.
3. Leave EOLR (provided) on all unused circuits.
4. See the instruction manual for circuit information, panel limits, and battery sizing.
5. For wire routing instructions through the releasing panel, see Note 3 on page 17 of the instruction manual.
6. See instruction manual for proper programming.
7. See instruction manual for list of compatible smoke detectors.
8. See specific system type data page for proper pressure switch settings.

**PROGRAM #5**

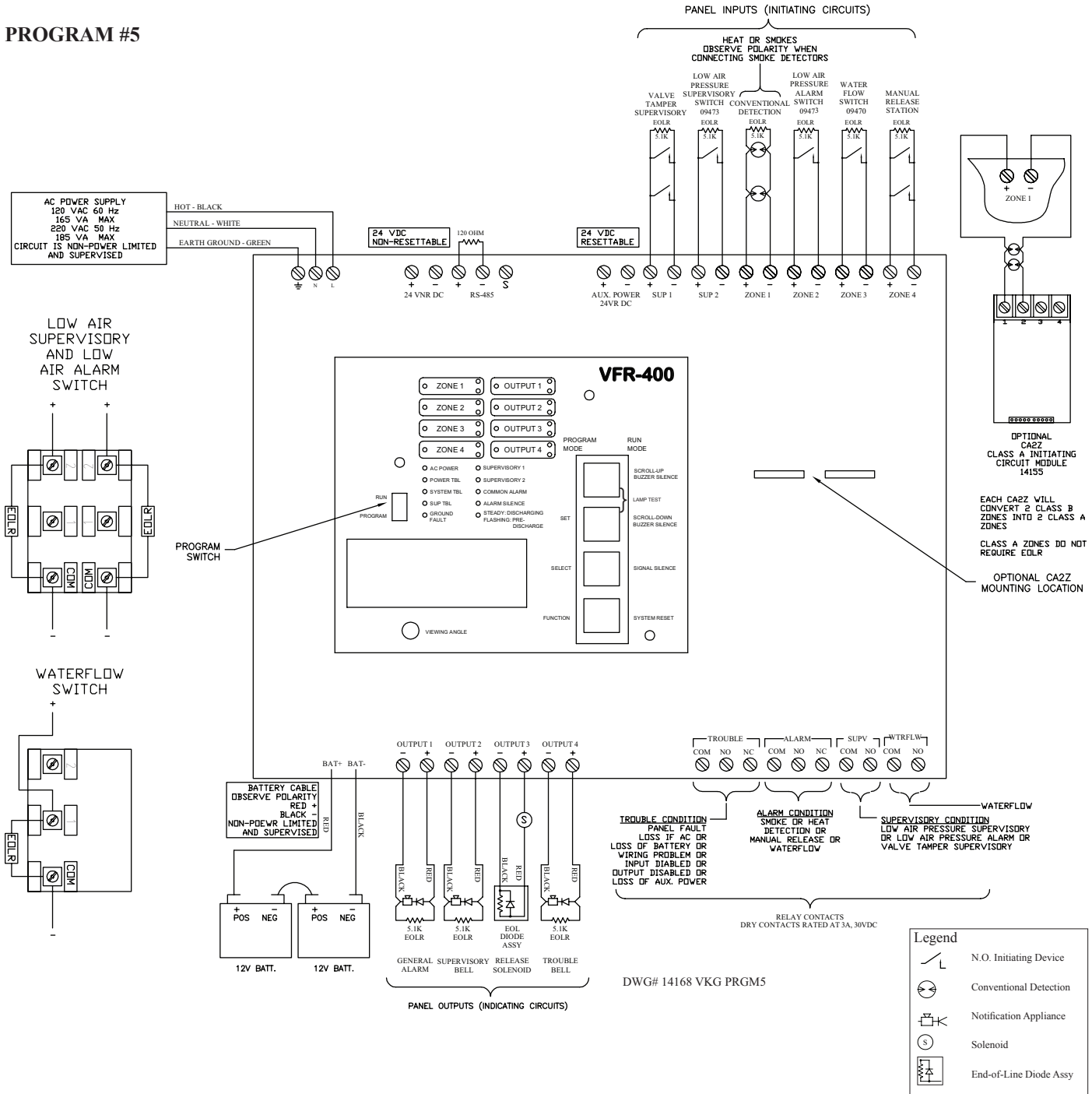

DWG# 14168 VKG PRGMS

1. Run field wiring and ensure connections are proper by metering wires. Resistance reading should be 5.1K ohms with end-of-line resistor (EOLR) at last device. The end-of-line resistor is located on the mother board. Remove as needed. Leave factory installed EOLR on all unused circuits.
2. Connect one circuit at a time and apply AC power.
3. Connect batteries to the panel.
4. Once last connection is made, move Program switch down.
5. Press the FUNCTION (bottom) button until the display reads "PASSWORD = 000".
6. To enter a password, press the SELECT button until the proper number is displayed above the ^ symbol, then press the SET button to move to the next digit. After entering the third number the display will change. (All panels are shipped with a 000 password.)
7. Press the FUNCTION (bottom) button until the display reads "PROGRAM #5".
8. Press the SELECT button until the display reads "PROGRAM #5".
9. Press the SET button.
10. The panel is completely programmed except for the custom banner and zone messages. Move the program switch back up.

<b>PROGRAM #6</b>						
For One Sprinkler System						
Viking Sprinkler System Types	Release Zone and Manual Release Zone	1. FIRECYCLE III Single Interlocked Preaction Multicycle System				
		2. FIRECYCLE III Single Interlocked Preaction Multicycle System - NYC Special				
OUTPUTS (Indicating Circuits)	ZONES (Initiating Circuits)					
	SUP 1	SUP 2	#1	#2	#3	#4
	Low Air Supervisory Zone	Valve Tamper Supervisory Zone	FIRECYCLE Detector Zone	Low Air Alarm Zone	Waterflow Zone	Manual Release Zone
#1 General Alarm			X		X	X
#2 Supervisory Bell	X	X		X		
#3 Release Solenoid			X			X
#4 N/O Solenoid			X	X	X	
OPERATION DESCRIPTION						
Inputs:	FIRECYCLE Detector zone, Low Air Alarm zone, 1 Waterflow zone, Manual Release zone, 2 Supervisory zones					
Outputs:	1 General Alarm, 1 Supervisory Alarm, 1 Release Solenoid, and 1 N/O Solenoid					
Operation:	Activation of FIRECYCLE Detector zone #1 will activate output #1 (General Alarm), output #3 (Release Solenoid), and output #4 (N/O Solenoid)					
	Activation of Low Air Alarm zone #2 will activate output #2 (Supervisory Bell) and output #4 (N/O Solenoid)					
	Activation of Waterflow zone #3 will activate output #1 (General Alarm) and output #4 (N/O Solenoid)					
	Activation of Manual Release zone #4 will activate output #1 (General Alarm) and output #3 (Release Solenoid)					
	Deactivation of FIRECYCLE Detector zone #1 will start soak timer, when timer cycle is complete output #3 (Release Solenoid) is deactivated					
	Activation of Low Air Supervisory Zone #1 or Valve Tamper Supervisory zone #2 will activate output #2 (Supervisory Bell)					

**NOTES:**

1. Connect EOL Diode assembly IN SERIES as shown with Solenoid on output #3 (Release Solenoid) and output #4 (N/O Solenoid). Black wire to negative terminal on panel and Red wire through Solenoid to positive terminal on panel.
2. Polarity is shown on indicating circuits in an activated (in alarm) condition.
3. Leave EOLR (provided) on all unused circuits.
4. See the instruction manual for circuit information, panel limits, and battery sizing.
5. For wire routing instructions through the releasing panel, see Note 3 on page 17 of the instruction manual.
6. See instruction manual for proper programming.
7. See specific system type data page for proper pressure switch settings.
8. Connect EOL resistor after last FIRECYCLE detector on return line to common terminal in FIRECYCLE Detector zone #1.
9. Set the soak timer to desired duration period. Factory setting is continuous. Recommend 60 seconds minimum.
10. Loss of DC power below 20 volt causes output #3 (Release Solenoid) and output #4 (N/O Solenoid) to drop out.
11. Use only Viking FIRECYCLE detectors on FIRECYCLE Detector zone #1.
12. Refer to Viking technical data sheet F\_051304 for Firecycle single interlock multi-cycle operation.



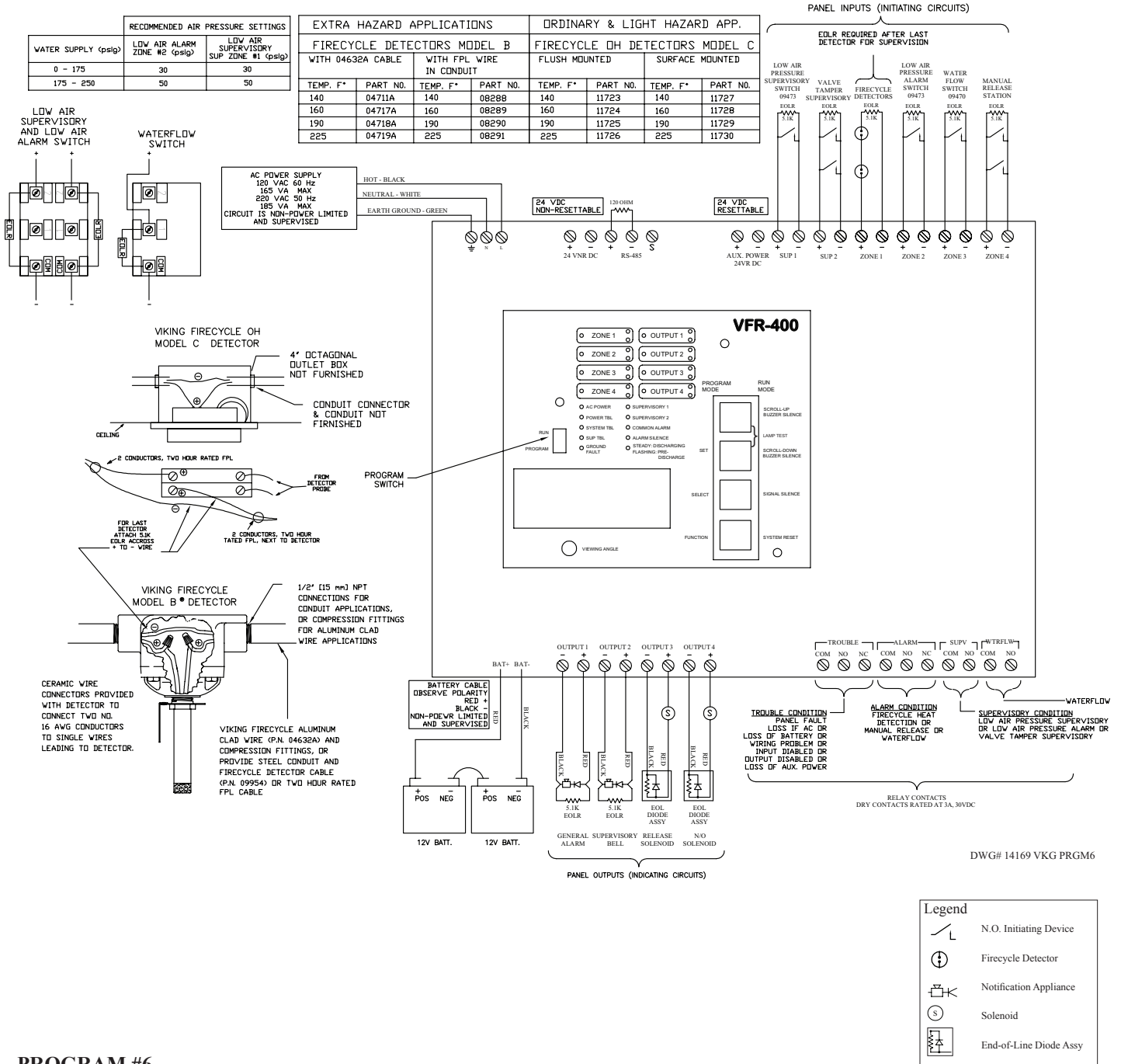

**PROGRAM #6**

1. Run field wiring and ensure connections are proper by metering wires. Resistance reading should be 5.1K ohms with end-of-line resistor (EOLR) at last device. The end-of-line resistor is located on the mother board. Remove as needed. Leave factory installed EOLR on all unused circuits.
2. Connect one circuit at a time and apply AC power.
3. Connect batteries to the panel.
4. Once last connection is made, move Program switch down.
5. Press the FUNCTION (bottom) button until the display reads "PASSWORD = 000".
6. To enter a password, press the SELECT button until the proper number is displayed above the ^ symbol, then press the SET button to move to the next digit. After entering the third number the display will change. (All panels are shipped with a 000 password.)
7. Press the FUNCTION (bottom) button until the display reads "PROGRAM #6".
8. Press the SELECT button until the display reads "PROGRAM #6".
9. Press the SET button.
10. The panel is completely programmed except for the custom banner and zone messages. Move the program switch back up.

PROGRAM #7						
For One Sprinkler System						
Viking Sprinkler System Types	2 Cross Release Zones and Manual Release Zone	1. FIRECYCLE III Double Interlocked Preaction Multicycle System				
		2. FIRECYCLE III Double Interlocked Preaction Multicycle System - NYC Special				
OUTPUTS (Indicating Circuits)	ZONES (Initiating Circuits)					
	SUP 1	SUP 2	#1	#2	#3	#4
	Low Air Supervisory Zone	Valve Tamper Supervisory Zone	FIRECYCLE Detector Zone	Low Air Alarm Zone	Waterflow Zone	Manual Release Zone
#1 General Alarm			X		X	X
#2 Supervisory Bell	X	X		X		
#3 Release Solenoid			X X	X X		X
#4 N/O Solenoid				X	X	
OPERATION DESCRIPTION						
Inputs:	1 FIRECYCLE Detector zone, 1 Low Air Alarm zone, 1 Waterflow zone, 1 Manual Release zone, 2 Supervisory zones					
Outputs:	1 General Alarm, 1 Supervisory Bell, 1 Release Solenoid, and 1 N/O Solenoid					
Operation:	Simultaneous activation of both the FIRECYCLE Detector zone #1 and the Low Air alarm zone #2 will activate output #1 (General Alarm), output #2 (Supervisory Bell), output #3 (Release Solenoid), and output #4 (N/O Solenoid).					
	Activation of FIRECYCLE Detector zone #1 will activate output #1 (General Alarm)					
	Activation of Low Air Alarm zone #2 alone will activate output #2 (Supervisory Bell) and output #4 (N/O Solenoid)					
	Activation of Waterflow zone #3 will activate output #1 (General Alarm) and output #4 (N/O solenoid)					
	Activation of Manual Release zone #4 will activate output #1 (General Alarm) and output #3 (Release Solenoid)					
	Deactivation of FIRECYCLE Detector zone #1 will start soak timer, when timer cycle is complete the output #3 (Release Solenoid) is deactivated.					
	Activation of Low Air Supervisory zone #1 or Valve Tamper Supervisory zone #2 will activate output #2 (Supervisory Bell)					

XX = Cross-Zoned

**NOTES:**

1. Connect EOL Diode assembly IN SERIES as shown with Solenoid on output #3 (Release Solenoid) and output #4 (N/O Solenoid). Black wire to negative terminal on panel and Red wire through Solenoid to positive terminal on panel.
2. Polarity is shown on indicating circuits in an activated (in alarm) condition.
3. Leave EOLR (provided) on all unused circuits.
4. See the instruction manual for circuit information, panel limits, and battery sizing.
5. For wire routing instructions through the releasing panel, see Note 3 on page 17 of the instruction manual.
6. See instruction manual for proper programming.
7. See specific system type data page for proper pressure switch settings.
8. Connect EOL resistor after last FIRECYCLE detector on return line to common terminal in FIRECYCLE Detector zone #1.
9. Set the soak timer to desired duration period. Factory setting is continuous. Recommend 60 seconds minimum.
10. Loss of DC power below 20 volt causes output #3 (Release Solenoid) to drop out.
11. Use only Viking FIRECYCLE detectors on FIRECYCLE Detector zone #1.
12. Refer to Viking technical data sheet F\_051304 for Firecycle double interlock multi-cycle operation.

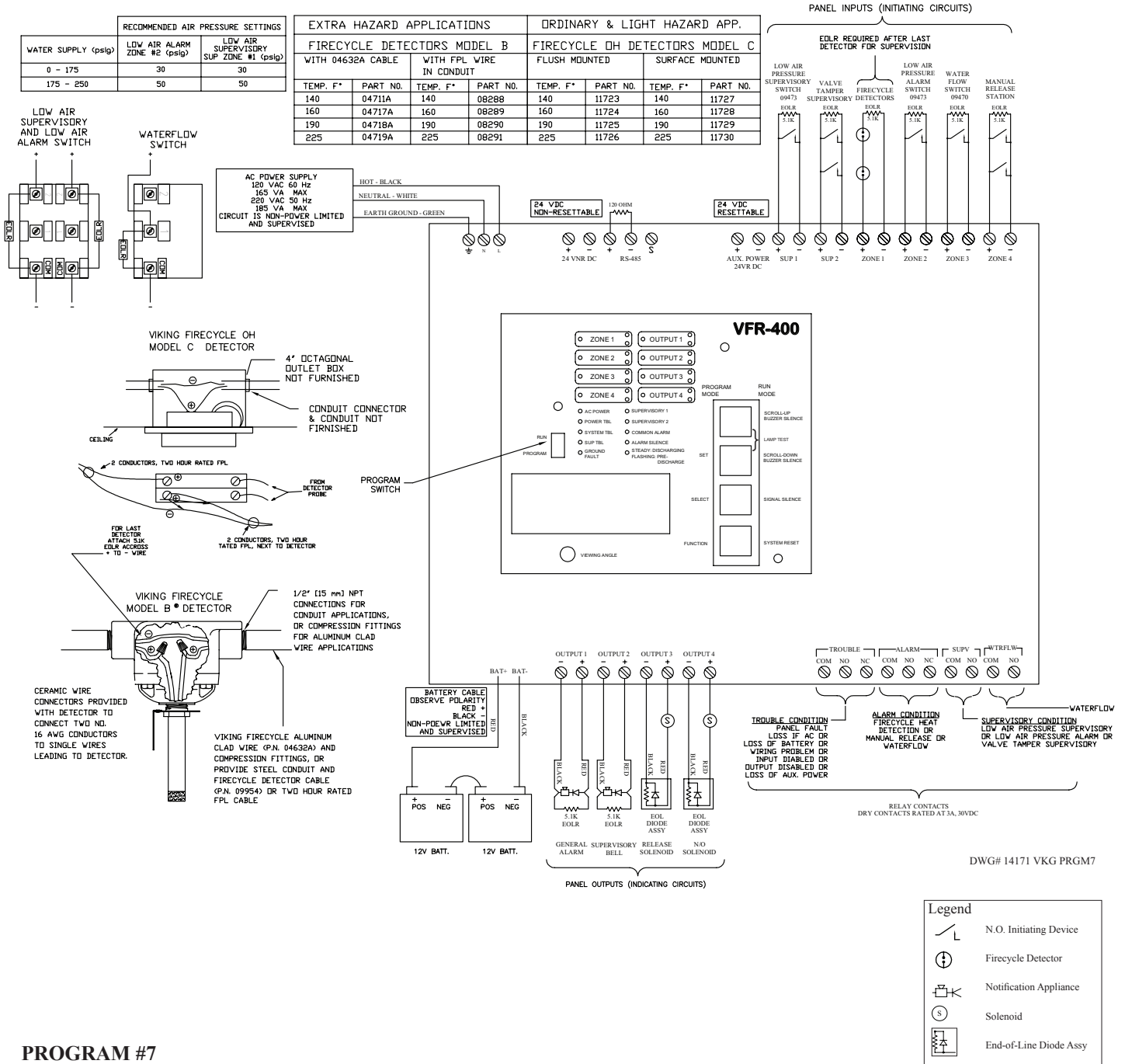

**PROGRAM #7**

1. Run field wiring and ensure connections are proper by metering wires. Resistance reading should be 5.1K ohms with end-of-line resistor (EOLR) at last device. The end-of-line resistor is located on the mother board. Remove as needed. Leave factory installed EOLR on all unused circuits.
2. Connect one circuit at a time and apply AC power.
3. Connect batteries to the panel.
4. Once last connection is made, move Program switch down.
5. Press the FUNCTION (bottom) button until the display reads "PASSWORD = 000".
6. To enter a password, press the SELECT button until the proper number is displayed above the ^ symbol, then press the SET button to move to the next digit. After entering the third number the display will change. (All panels are shipped with a 000 password.)
7. Press the FUNCTION (bottom) button until the display reads "PROGRAM #7".
8. Press the SELECT button until the display reads "PROGRAM #7".
9. Press the SET button.
10. The panel is completely programmed except for the custom banner and zone messages. Move the program switch back up.

<b>PROGRAM #8</b>						
For One Sprinkler System						
Viking Sprinkler System Types	1 Release Zone and Manual Release	1. FIRECYCLE III Deluge Multicycle System				
OUTPUTS (Indicating Circuits)	ZONES (Initiating Circuits)					
	SUP 1	SUP 2	#1	#2	#3	#4
	Supervisory Zone	Valve Tamper Supervisory Zone	FIRECYCLE Detector Zone	Supervisory Zone	Waterflow Zone	Manual Release Zone
#1 General Alarm			X		X	X
#2 Supervisory Bell	X	X		X		
#3 Release Solenoid			X			X
#4 N/O Solenoid			X		X	
OPERATION DESCRIPTION						
Inputs:	1 FIRECYCLE Detection zone, 1 Supervisory zone, 1 Waterflow zone, 1 Manual Release zone, 2 Supervisory zones					
Outputs:	1 General Alarm, 1 Supervisory Bell, 1 Release Solenoid, and 1 N/O Solenoid					
Operation:	Activation of FIRECYCLE Detector zone #1 will activate output #1 (General Alarm), output #3 (Release Solenoid) and output #4 (N/O Solenoid)					
	Activation of Supervisory zone #2 will activate output #2 (Supervisory Bell)					
	Activation of Waterflow Alarm zone #3 will activate output #1 (General Alarm) and output #4 (N/O Solenoid)					
	Activation of Manual Release zone #4 will activate output #1 (General Alarm) and output #3 (Release Solenoid)					
	Deactivation of FIRECYCLE Detector zone #1 will start soak timer, when timer cycle is complete the output #3 (Release Solenoid) is deactivated.					
	Activation of Supervisory zone #1 or Valve Tamper Supervisory Zone #2 will activate output #2 (Supervisory Bell)					

**NOTES:**

1. Connect EOL Diode assembly IN SERIES as shown with Solenoid on output #3 (Release Solenoid) and output #4 (N/O Solenoid). Black wire to negative terminal on panel and Red wire through Solenoid to positive terminal on panel.
2. Polarity is shown on indicating circuits in an activated (in alarm) condition.
3. Leave EOLR (provided) on all unused circuits.
4. See the instruction manual for circuit information, panel limits, and battery sizing.
5. For wire routing instructions through the releasing panel, see Note 3 on page 17 of the instruction manual.
6. See instruction manual for proper programming.
7. See specific system type data page for proper pressure switch settings.
8. Connect EOL resistor after last FIRECYCLE detector on return line to common terminal in FIRECYCLE Detector zone #1.
9. Set the soak timer to desired duration period. Factory setting is continuous. Recommend 60 seconds minimum.
10. Loss of DC power below 20 volt causes output #3 (Release Solenoid) and output #4 (N/O Solenoid) to drop out.
11. Use only Viking FIRECYCLE detectors on FIRECYCLE Detector zone #1.
12. Refer to Viking technical data sheet F\_051404 for Firecycle deluge multi-cycle operation.

**PROGRAM #8**

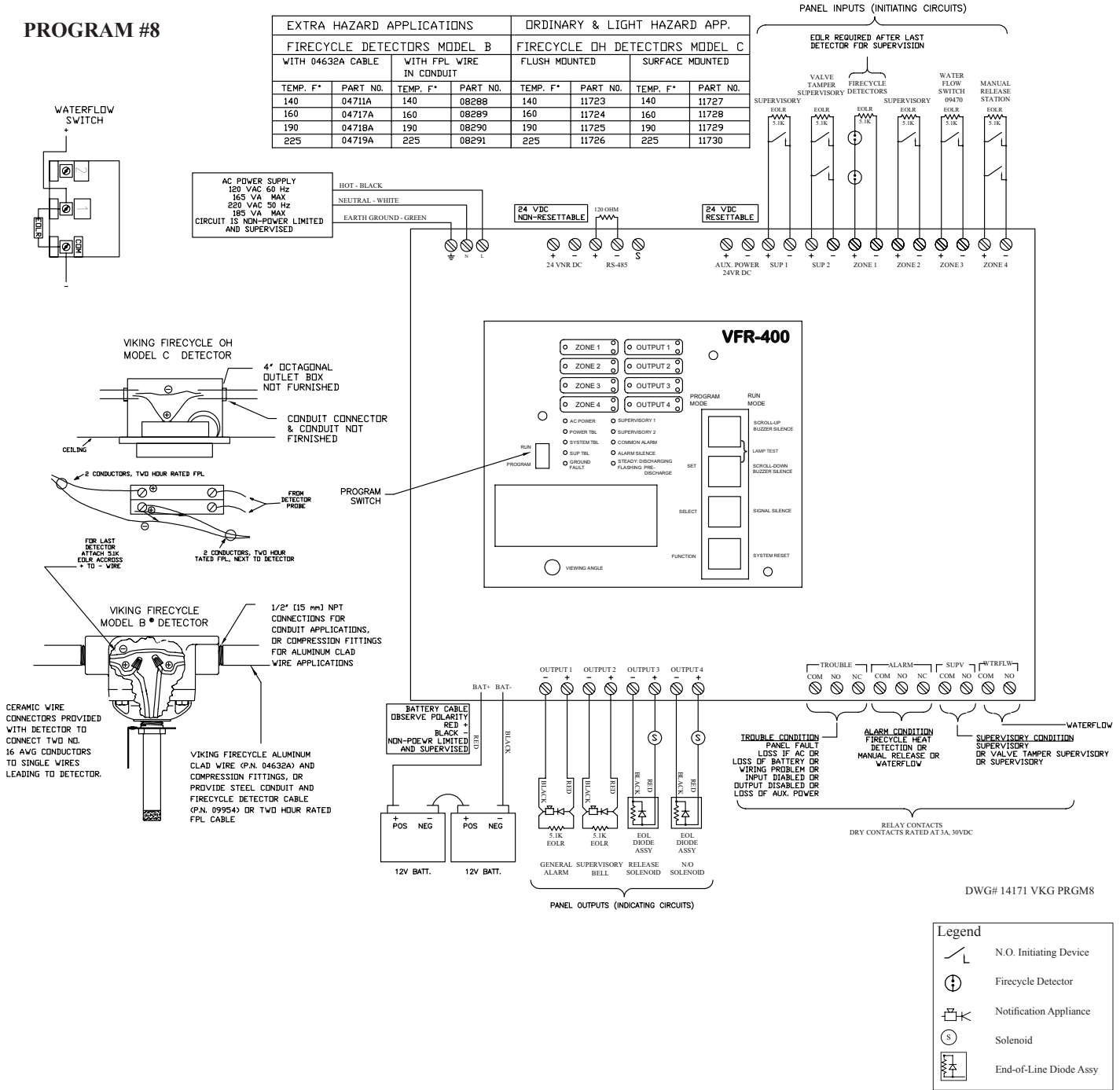

1. Run field wiring and ensure connections are proper by metering wires. Resistance reading should be 5.1K ohms with end-of-line resistor (EOLR) at last device. The end-of-line resistor is located on the mother board. Remove as needed. Leave factory installed EOLR on all unused circuits.
2. Connect one circuit at a time and apply AC power.
3. Connect batteries to the panel.
4. Once last connection is made, move Program switch down.
5. Press the FUNCTION (bottom) button until the display reads "PASSWORD = 000".
6. To enter a password, press the SELECT button until the proper number is displayed above the ^ symbol, then press the SET button to move to the next digit. After entering the third number the display will change. (All panels are shipped with a 000 password.)
7. Press the FUNCTION (bottom) button until the display reads "PROGRAM #8".
8. Press the SELECT button until the display reads "PROGRAM #8".
9. Press the SET button.
10. The panel is completely programmed except for the custom banner and zone messages. Move the program switch back up.

<b>PROGRAM #9</b>						
For One Sprinkler System						
Viking Sprinkler System Types	1 Release Zone and Manual Release Zone	1. FIRECYCLE III Wet Multicycle System				
OUTPUTS (Indicating Circuits)	ZONES (Initiating Circuits)					
	SUP 1	SUP 2	#1	#2	#3	#4
	Supervisory Zone	Valve Tamper Supervisory Zone	FIRECYCLE Detector Zone	Supervisory Zone	Waterflow Zone	Manual Release Zone
#1 General Alarm			X		X	X
#2 Supervisory Bell	X	X		X		
#3 Release Solenoid			X			X
#4 N/O Solenoid			X		X	
OPERATION DESCRIPTION						
Inputs:	1 FIRECYCLE Detection zone, 1 Supervisory zone, 1 Waterflow zone, 1 Manual Release zone, 2 Supervisory zones					
Outputs:	1 General Alarm, 1 Supervisory Bell, 1 Release Solenoid, and 1 N/O Solenoid					
Operation:	Activation of FIRECYCLE Detector zone #1 will activate output #1 (General Alarm), output #3 (Release Solenoid) and output #4 (N/O Solenoid)					
	Activation of Supervisory zone #2 will activate output #2 (Supervisory Bell)					
	Activation of Waterflow Alarm zone #3 will activate output #1 (General Alarm) and output #4 (N/O Solenoid)					
	Activation of Manual Release zone #4 will activate output #1 (General Alarm) and output #3 (Release Solenoid)					
	Deactivation of FIRECYCLE Detector zone #1 will start soak timer, when timer cycle is complete the output #3 (Release Solenoid) is deactivated.					
	Activation of Supervisory zone #1 or Valve Tamper Supervisory zone #2 will activate output #2 (Supervisory Bell)					

**NOTES:**

1. Connect EOL Diode assembly IN SERIES as shown with Solenoid on output #3 (Release Solenoid) and output #4 (N/O Solenoid). Black wire to negative terminal on panel and Red wire through Solenoid to positive terminal on panel.
2. Polarity is shown on indicating circuits in an activated (in alarm) condition.
3. Leave EOLR (provided) on all unused circuits.
4. See the instruction manual for circuit information, panel limits, and battery sizing.
5. For wire routing instructions through the releasing panel, see Note 3 on page 17 of the instruction manual.
6. See instruction manual for proper programming.
7. See specific system type data page for proper pressure switch settings.
8. Connect EOL resistor after last FIRECYCLE detector on return line to common terminal in FIRECYCLE Detector zone #1.
9. Set the soak timer to desired duration period. Factory setting is continuous. Recommend 60 seconds minimum.
10. Loss of DC power below 20 volt causes output #3 (Release Solenoid) and output #4 (N/O Solenoid) to drop out.
11. Use only Viking FIRECYCLE detectors on FIRECYCLE Detector zone #1.
12. Refer to Viking technical data sheet F\_051504 for Firecycle multi-cycle wet system operation.

**PROGRAM #9**

EXTRA HAZARD APPLICATIONS				ORDINARY & LIGHT HAZARD APP.			
FIRECYCLE DETECTORS MODEL B				FIRECYCLE OH DETECTORS MODEL C			
WITH 04632A CABLE		WITH FPL WIRE IN CONDUIT		FLUSH MOUNTED		SURFACE MOUNTED	
TEMP. F*	PART NO.	TEMP. F*	PART NO.	TEMP. F*	PART NO.	TEMP. F*	PART NO.
140	04711A	140	08288	140	11723	140	11727
160	04717A	160	08289	160	11724	160	11728
190	04718A	190	08290	190	11725	190	11729
225	04719A	225	08291	225	11726	225	11730

PANEL INPUTS (INITIATING CIRCUITS)

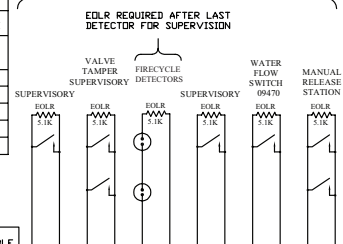

AC POWER SUPPLY  
120 VAC 60 Hz  
185 VA MAX  
220 VAC 50 Hz  
185 VA MAX  
CIRCUIT IS NON-POWER LIMITED AND SUPERVISED

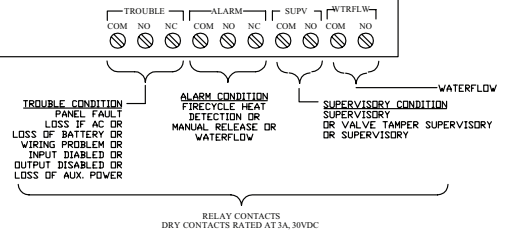
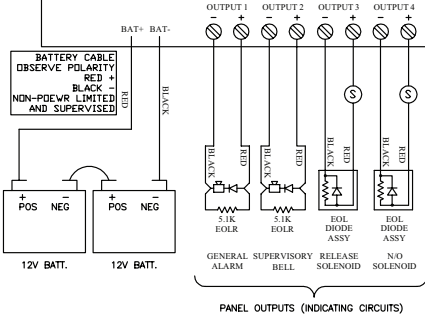
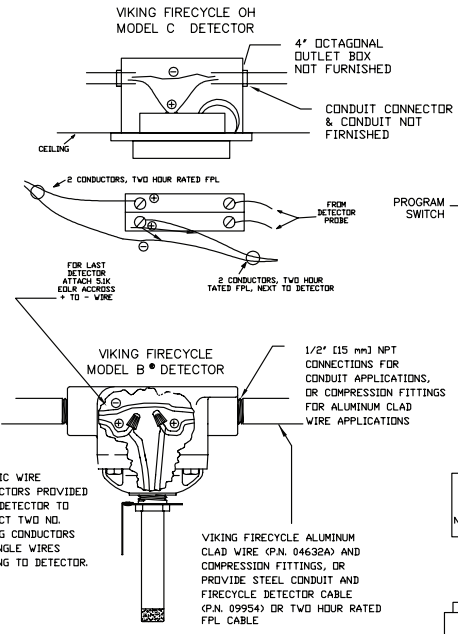
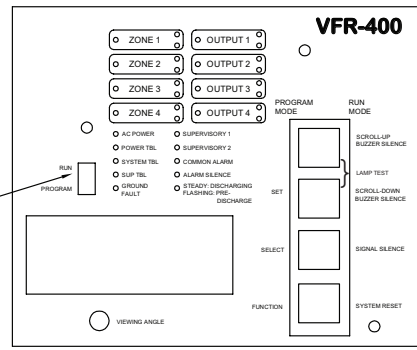
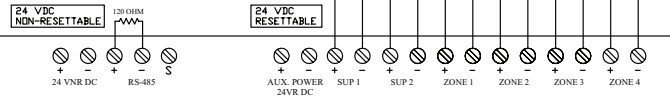
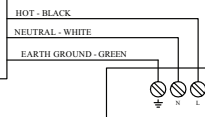

DWG# 14172 VKG PRGM9

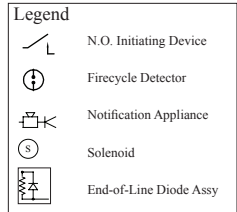

1. Run field wiring and ensure connections are proper by metering wires. Resistance reading should be 5.1K ohms with end-of-line resistor (EOLR) at last device. The end-of-line resistor is located on the mother board. Remove as needed. Leave factory installed EOLR on all unused circuits.
2. Connect one circuit at a time and apply AC power.
3. Connect batteries to the panel.
4. Once last connection is made, move Program switch down.
5. Press the FUNCTION (bottom) button until the display reads "PASSWORD = 000".
6. To enter a password, press the SELECT button until the proper number is displayed above the ^ symbol, then press the SET button to move to the next digit. After entering the third number the display will change. (All panels are shipped with a 000 password.)
7. Press the FUNCTION (bottom) button until the display reads "PROGRAM #9".
8. Press the SELECT button until the display reads "PROGRAM #9".
9. Press the SET button.
10. The panel is completely programmed except for the custom banner and zone messages. Move the program switch back up.

<b>PROGRAM #10</b>						
For One Sprinkler System- SUREFIRE Single Interlock						
Viking Sprinkler System Types	Release Zone and Manual Release Zone	1. SUREFIRE Single Interlocked Preaction System				
		2. SUREFIRE Single Interlocked Preaction System - NYC Special				
		3. SUREFIRE Single Interlocked Preprimed Preaction System				
		4. SUREFIRE Single Interlocked Preprimed Preaction System - NYC Special				
OUTPUTS (Indicating Circuits)	ZONES (Initiating Circuits)					
	SUP 1	SUP 2	#1	#2	#3	#4
	Valve Tamper Supervisory Zone	Low Air Supervisory Zone	Conventional Detection Zone	Low Air Alarm Zone	Waterflow Zone	Manual Release Zone
#1 General Alarm			X		X	X
#2 Supervisory Bell	X	X		X		
#3 Release Solenoid			X			X
#4 N/O Solenoid				X		
OPERATION DESCRIPTION						
Inputs:	1 Conventional Detection zone, 1 Waterflow zone, 1 Low Air Alarm zone, 1 Manual Release zone, 2 Supervisory zones					
Outputs:	1 General Alarm, 1 N/O Solenoid, 1 Release Solenoid, 1 Supervisory Bell					
Operation:	Activation of Conventional Detection zone #1 will activate output #3 (Release Solenoid) and output #1 (General Alarm)					
	Activation of Low Air Alarm zone #2 will activate output #2 (Supervisory Bell) and output #4 (N/O Solenoid)					
	Activation of Waterflow zone #3 will activate output #1 (General Alarm)					
	Activation of Manual Release zone #4 will activate output #3 (Release Solenoid) and output #1 (General Alarm)					
	Activation of Valve Tamper Supervisory zone #1 or Low Air Supervisory zone #2 will activate output#2 (Supervisory Bell)					
	A trouble condition will prevent output #4 (N/O Solenoid) from activating					

**NOTES:**

1. Connect EOL Diode assembly IN SERIES as shown with Solenoid on output #3 (Release Solenoid) and output #4 (Release Solenoid). Black wire to negative terminal on panel and Red wire through Solenoid to positive terminal on panel.
2. Polarity is shown on indicating circuits in an activated (in alarm) condition.
3. Leave EOLR (provided) on all unused circuits.
4. See the instruction manual for circuit information, panel limits, and battery sizing.
5. For wire routing instructions through the releasing panel, see Note 3 on page 17 of the instruction manual.
6. See instruction manual for proper programming.
7. See instruction manual for list of compatible smoke detectors.
8. See specific system type data page for proper pressure switch settings.
9. Loss of DC power below 20 volt causes output #3 (Release Solenoid) and output #4 (N/O Solenoid) to drop out.
10. See Viking technical data sheet F\_051604 for Surefire single interlock operation.



**PROGRAM #10**

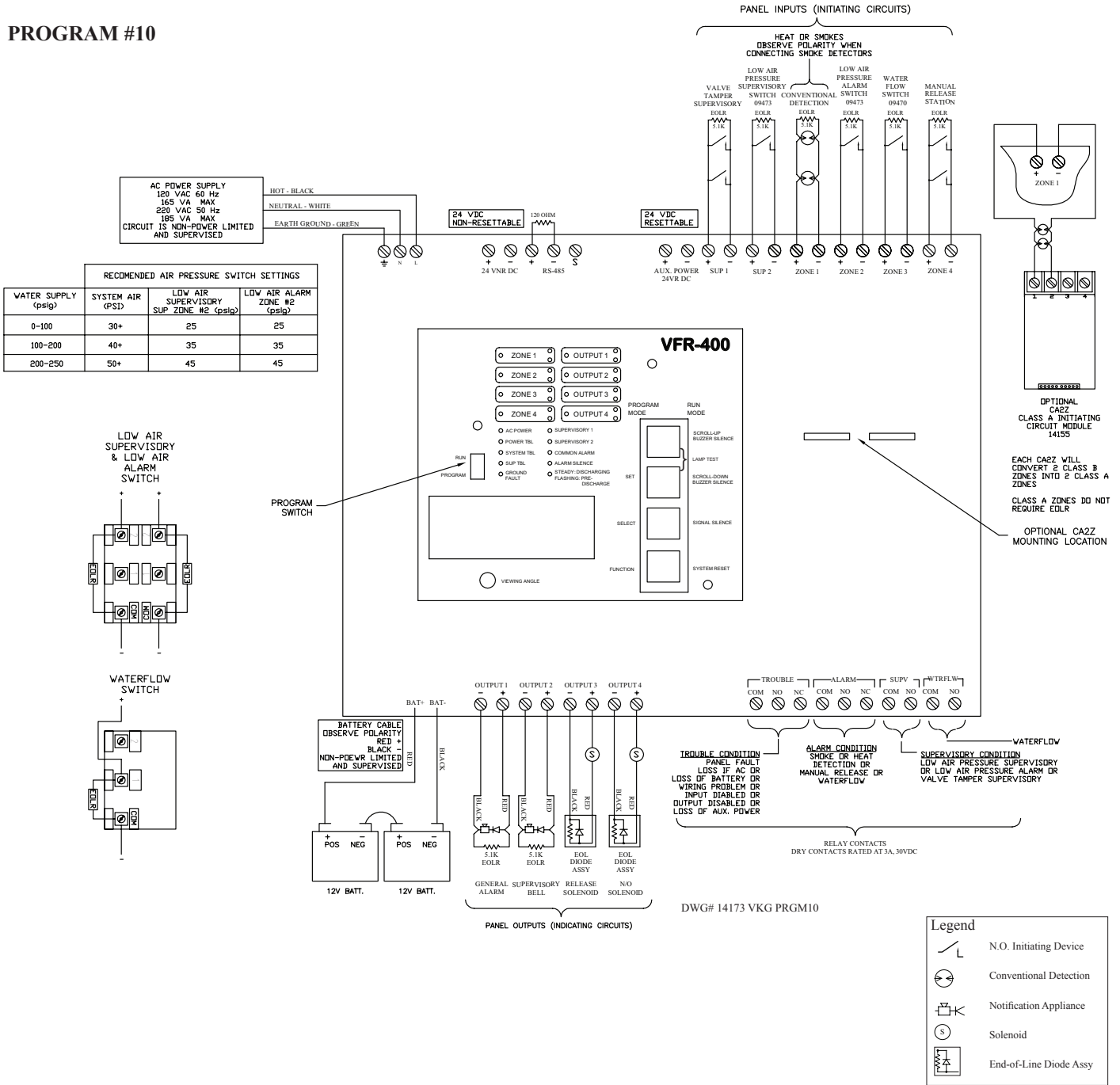

1. Run field wiring and ensure connections are proper by metering wires. Resistance reading should be 5.1K ohms with end-of-line resistor (EOLR) at last device. The end-of-line resistor is located on the mother board. Remove as needed. Leave factory installed EOLR on all unused circuits.
2. Connect one circuit at a time and apply AC power.
3. Connect batteries to the panel.
4. Once last connection is made, move Program switch down.
5. Press the FUNCTION (bottom) button until the display reads "PASSWORD = 000".
6. To enter a password, press the SELECT button until the proper number is displayed above the ^ symbol, then press the SET button to move to the next digit. After entering the third number the display will change. (All panels are shipped with a 000 password.)
7. Press the FUNCTION (bottom) button until the display reads "PROGRAM #10".
8. Press the SELECT button until the display reads "PROGRAM #10".
9. Press the SET button.
10. The panel is completely programmed except for the custom banner and zone messages. Move the program switch back up.

<b>PROGRAM #11</b>						
For One Sprinkler System						
Viking Sprinkler System Types	2 Cross Release Zones and Manual Release Zone	1. SUREFIRE Double Interlocked Preaction System				
		2. SUREFIRE Double Interlocked Preaction System - NYC Special				
		3. SUREFIRE Double Interlocked Preprimed Preaction System				
		4. SUREFIRE Double Interlocked Preprimed Preaction System - NYC Special				
OUTPUTS (Indicating Circuits)	ZONES (Initiating Circuits)					
	SUP 1	SUP 2	#1	#2	#3	#4
	Valve Tamper Supervisory Zone	Low Air Supervisory Zone	Conventional Detection Zone	Low Air Alarm Zone	Waterflow Zone	Manual Release Zone
#1 General Alarm			X		X	X
#2 Supervisory Bell	X	X		X		
#3 Release Solenoid			X X	X X		X
#4 N/O Solenoid				X		
OPERATION DESCRIPTION						
Inputs:	1 Conventional Detection zone, 1 Low Air Alarm zone, 1 Waterflow zone, 1 Manual Release zone, 2 Supervisory zones					
Outputs:	1 General Alarm, 1 Supervisory Bell, 1 Release Solenoid, 1 N/O Solenoid					
Operation:	Simultaneous activation of both the Conventional Detection zone #1 and the Low Air Alarm zone #2 will activate output #3 (Release Solenoid), output #1 (General Alarm), and output #4 (N/O Solenoid)					
	Activation of Conventional Detection zone #1 will activate output #1 (General Alarm)					
	Activation of Low Air Alarm zone #2 will activate output #2 (Supervisory Bell) and output #4 (N/O Solenoid)					
	Activation of Waterflow zone #3 will activate output #1 (General Alarm)					
	Activation of Valve Tamper Supervisory zone #1 or Low Air Supervisory zone #2 will activate output #2 (Supervisory Bell)					
	Activation of Manual Release zone #4 will activate output #3 (Release Solenoid) and output #1 (General Alarm)					
A trouble condition will prevent output #4 (N/O Solenoid) from activating						

XX = Cross-Zoned

**NOTES:**

1. Connect EOL Diode assembly IN SERIES as shown with Solenoid on output #3 (Release Solenoid) and output #4 (Release Solenoid). Black wire to negative terminal on panel and Red wire through Solenoid to positive terminal on panel.
2. Polarity is shown on indicating circuits in an activated (in alarm) condition.
3. Leave EOLR (provided) on all unused circuits.
4. See the instruction manual for circuit information, panel limits, and battery sizing.
5. For wire routing instructions through the releasing panel, see Note 3 on page 17 of the instruction manual.
6. See instruction manual for proper programming.
7. See instruction manual for list of compatible smoke detectors.
8. See specific system type data page for proper pressure switch settings.
9. Loss of DC power below 20 volt causes output #3 (Release Solenoid) and output #4 (N/O Solenoid) to drop out.
10. See Viking technical data sheet F\_051704 for Surefire double interlock operation.

**PROGRAM #11**

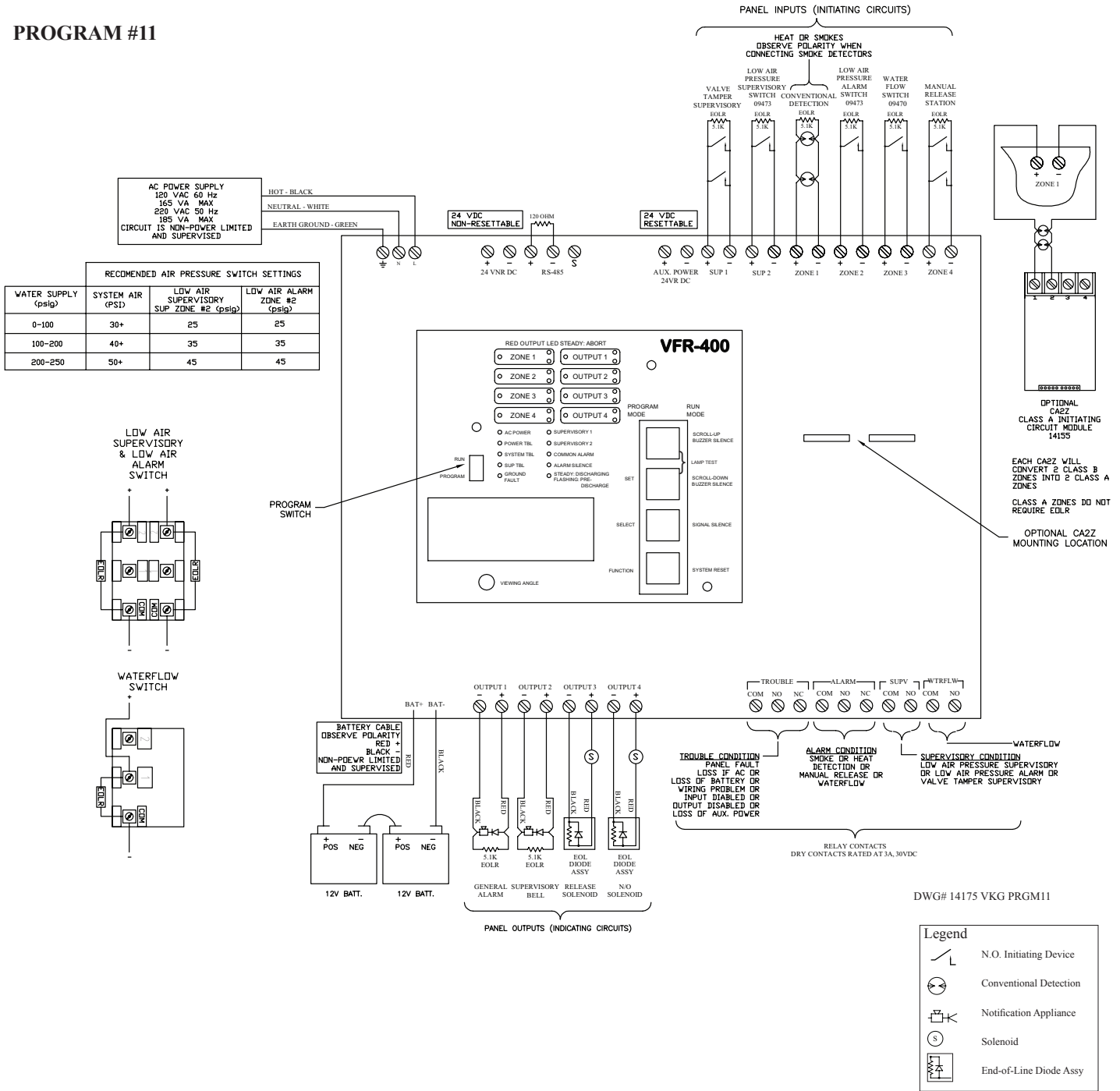

1. Run field wiring and ensure connections are proper by metering wires. Resistance reading should be 5.1K ohms with end-of-line resistor (EOLR) at last device. The end-of-line resistor is located on the mother board. Remove as needed. Leave factory installed EOLR on all unused circuits.
2. Connect one circuit at a time and apply AC power.
3. Connect batteries to the panel.
4. Once last connection is made, move Program switch down.
5. Press the FUNCTION (bottom) button until the display reads "PASSWORD = 000".
6. To enter a password, press the SELECT button until the proper number is displayed above the ^ symbol, then press the SET button to move to the next digit. After entering the third number the display will change. (All panels are shipped with a 000 password.)
7. Press the FUNCTION (bottom) button until the display reads "PROGRAM #11".
8. Press the SELECT button until the display reads "PROGRAM #11".
9. Press the SET button.
10. The panel is completely programmed except for the custom banner and zone messages. Move the program switch back up.

<b>PROGRAM #12</b>						
For One Sprinkler System						
Viking Sprinkler System Types	2 Cross Release Zones, Waterflow Zone, and Manual Release Zone	1. Single Interlocked Preaction System with Electric Release				
		2. Deluge System with Electric Release				
		3. Non-Interlocked Preaction system with Electric Release				
		4. Double Interlocked Preaction System with Electric/Pneu-Lectric Release				
OUTPUTS (Indicating Circuits)	ZONES (Initiating Circuits)					
	SUP 1	SUP 2	#1	#2	#3	#4
	Valve Tamper Supervisory Zone	Low Air Supervisory Zone	Conventional Detection Zone	Conventional Detection Zone	Waterflow Zone	Manual Release Zone
#1 General Alarm			X	X	X	X
#2 Waterflow					X	
#3 Release Solenoid			X X	X X		X
#4 Supervisory Bell	X	X				
OPERATION DESCRIPTION						
Inputs:	2 Conventional Detection zones, 1 Waterflow zone, 1 Manual Release zone, 2 Supervisory zones					
Outputs:	1 General Alarm, 1 Waterflow, 1 Release Solenoid, 1 Supervisory Bell					
Operation:	Simultaneous activation of both the Conventional Detection zone #1 and the Conventional Detector zone #2 will activate output #3 (Release Solenoid) and output #1 (General Alarm)					
	Activation of Conventional Detection zone #1 will activate output #1 (General Alarm)					
	Activation of Conventional Detection zone #2 will activate output #1 (General Alarm)					
	Activation of Waterflow zone #3 will activate output #2 (Waterflow) and output #1 (General Alarm)					
	Activation of Manual Release zone #4 will activate output #3 (Release Solenoid) and output #1 (General Alarm)					
	Activation of Valve Tamper Supervisory zone #1 or Low Air Supervisory zone #2 will activate output #4 (Supervisory Bell)					

XX = Cross-Zoned

**NOTES:**

1. Connect EOL Diode assembly IN SERIES as shown with Solenoid on output #3 (Release Solenoid) and output #4 (Release Solenoid). Black wire to negative terminal on panel and Red wire through Solenoid to positive terminal on panel.
2. Polarity is shown on indicating circuits in an activated (in alarm) condition.
3. Leave EOLR (provided) on all unused circuits.
4. See the instruction manual for circuit information, panel limits, and battery sizing.
5. For wire routing instructions through the releasing panel, see Note 3 on page 17 of the instruction manual.
6. See instruction manual for proper programming.
7. See instruction manual for list of compatible smoke detectors.
8. See specific system type data page for proper pressure switch settings.

**PROGRAM #12**

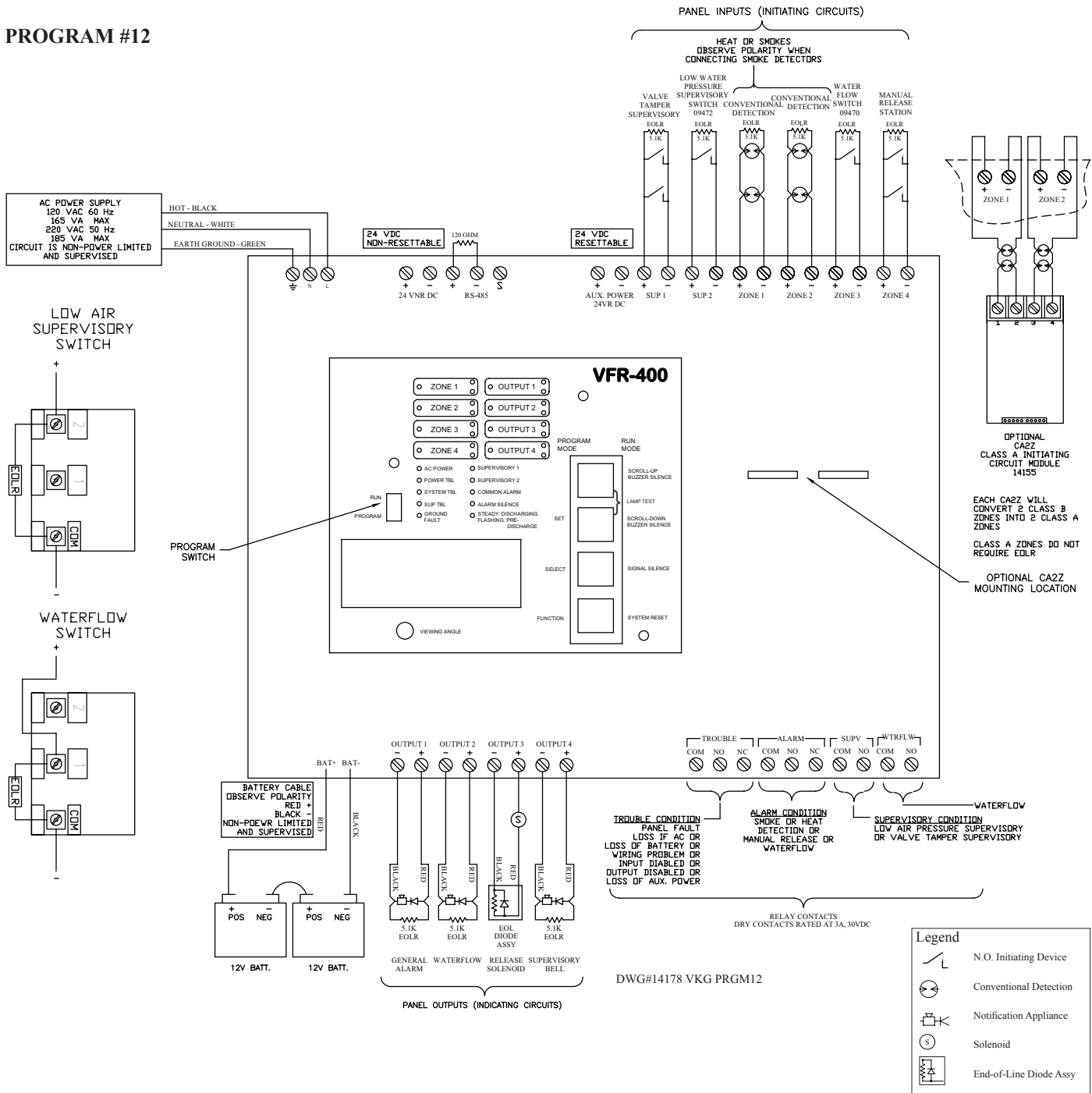

1. Run field wiring and ensure connections are proper by metering wires. Resistance reading should be 5.1K ohms with end-of-line resistor (EOLR) at last device. The end-of-line resistor is located on the mother board. Remove as needed. Leave factory installed EOLR on all unused circuits.
2. Connect one circuit at a time and apply AC power.
3. Connect batteries to the panel.
4. Once last connection is made, move Program switch down.
5. Press the FUNCTION (bottom) button until the display reads "PASSWORD = 000".
6. To enter a password, press the SELECT button until the proper number is displayed above the ^ symbol, then press the SET button to move to the next digit. After entering the third number the display will change. (All panels are shipped with a 000 password.)
7. Press the FUNCTION (bottom) button until the display reads "PROGRAM #12".
8. Press the SELECT button until the display reads "PROGRAM #12".
9. Press the SET button.
10. The panel is completely programmed except for the custom banner and zone messages. Move the program switch back up.

<b>PROGRAM #13</b>						
For One Sprinkler System						
Viking Sprinkler System Types (UK only)	2 Release Zones, Waterflow Zone, and Manual Release Zone	E-1 Single-interlocked preaction system with Electric-Pneumatic release				
OUTPUTS (Indicating Circuits)	ZONES (Initiating Circuits)					
	SUP 1	SUP 2	#1	#2	#3	#4
	Valve Tamper Supervisory Zone	Low Air Supervisory Zone	Conventional Detection Zone	Waterflow Zone	Manual Release Zone	Conventional Detection Zone
#1 General Alarm			X	X	X	X
#2 Low air/Tamper	X	X				
#3 Release Solenoid #1			X		X	X
#4 Release Solenoid #2			X		X	X
OPERATION DESCRIPTION						
Inputs:	2 Conventional Detection zones, 1 Waterflow zone, 1 Manual Release zone, 2 Supervisory zones					
Outputs:	1 General Alarm, 1 Low Air/Tamper, 2 Release Solenoids					
Operation:	Activation of Conventional Detection zone #1 or #4 or manual release zone #3 will activate outputs #3 and #4 (release solenoids) and output #1 (General Alarm)					
	Activation of Waterflow zone #2 will activate output #1 (General Alarm)					
	Activation of Valve Tamper supervisory zone #1 or Low air supervisory zone #2 will activate output #2 (Low Air/Tamper)					

**NOTES:**

1. Connect EOL Diode assembly IN SERIES as shown with solenoids on outputs #3 and #4. Black wire to negative terminal on panel. Red wire through solenoid to positive terminal on panel.
2. Polarity is shown on indicating circuits in an activated (in alarm) condition.
3. Leave EOLR (provided) on all unused circuits.
4. See the instruction manual for circuit information, panel limits, and battery sizing.
5. For wire routing instructions through the releasing panel, see Note 3 on page 17 of the instruction manual.
6. See instruction manual for proper programming.
7. See instruction manual for list of compatible smoke detectors and solenoids.
8. See specific system type data page for proper pressure switch settings.

**PROGRAM #13**

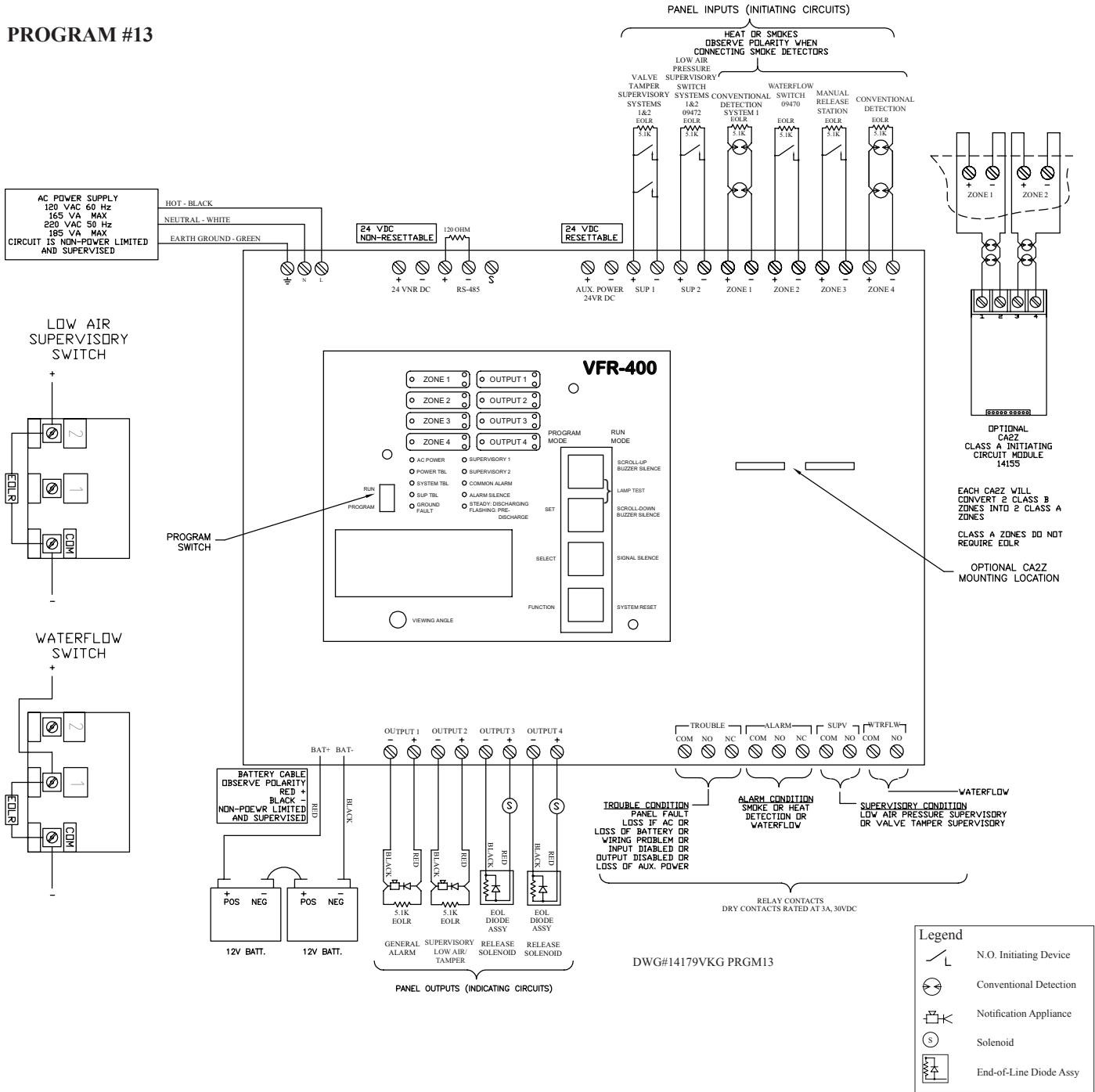

1. Run field wiring and ensure connections are proper by metering wires. Resistance reading should be 5.1K ohms with end-of-line resistor (EOLR) at last device. The end-of-line resistor is located on the mother board. Remove as needed. Leave factory installed EOLR on all unused circuits.
2. Connect one circuit at a time and apply AC power.
3. Connect batteries to the panel.
4. Once last connection is made, move Program switch down.
5. Press the FUNCTION (bottom) button until the display reads "PASSWORD = 000".
6. To enter a password, press the SELECT button until the proper number is displayed above the ^ symbol, then press the SET button to move to the next digit. After entering the third number the display will change. (All panels are shipped with a 000 password.)
7. Press the FUNCTION (bottom) button until the display reads "PROGRAM #X".
8. Press the SELECT button until the display reads "PROGRAM #13".
9. Press the SET button.
10. The panel is completely programmed except for the custom banner and zone messages. Move the program switch back up.

<b>PROGRAM #14</b>						
For One Sprinkler System						
Viking Sprinkler System Types (UK only)	2 Cross Release Zones, Waterflow Zone, and Manual Release Zone	E-1 Single-interlocked preaction system with Electric - Pneumatic release				
OUTPUTS (Indicating Circuits)	ZONES (Initiating Circuits)					
	SUP 1	SUP 2	#1	#2	#3	#4
	Valve Tamper Supervisory Zone	Low Air Supervisory Zone	Conventional Detection Zone	Conventional Detection Zone	Waterflow Zone	Manual Release Zone
#1 General Alarm			X	X	X	X
#2 Low air/Tamper	X	X				
#3 Release Solenoid #1			XX	XX		X
#4 Release Solenoid #2			XX	XX		X
OPERATION DESCRIPTION						
Inputs:	2 Conventional Detection zones, 1 Waterflow zone, 1 Manual Release zone, 2 Supervisory zones					
Outputs:	1 General Alarm, 1 Low Air/Tamper, 2 Release Solenoids					
Operation:	Activation of both Conventional Detection zone #1 and #2 or manual release zone #4 will activate outputs #3 and #4 (release solenoids) and output #1 (General Alarm)					
	Activation of Waterflow zone #3 will activate output #1 (General Alarm)					
	Activation of Valve Tamper supervisory zone #1 or Low air supervisory zone #2 will activate output #2 (Low Air/Tamper)					

**NOTES:**

1. Connect EOL Diode assembly IN SERIES as shown with solenoids on outputs #3 and #4. Black wire to negative terminal on panel. Red wire through solenoid to positive terminal on panel.
2. Polarity is shown on indicating circuits in an activated (in alarm) condition.
3. Leave EOLR (provided) on all unused circuits.
4. See the instruction manual for circuit information, panel limits, and battery sizing.
5. For wire routing instructions through the releasing panel, see Note 3 on page 17 of the instruction manual.
6. See instruction manual for proper programming.
7. See instruction manual for list of compatible smoke detectors and solenoids.
8. See specific system type data page for proper pressure switch settings.



**PROGRAM #14**

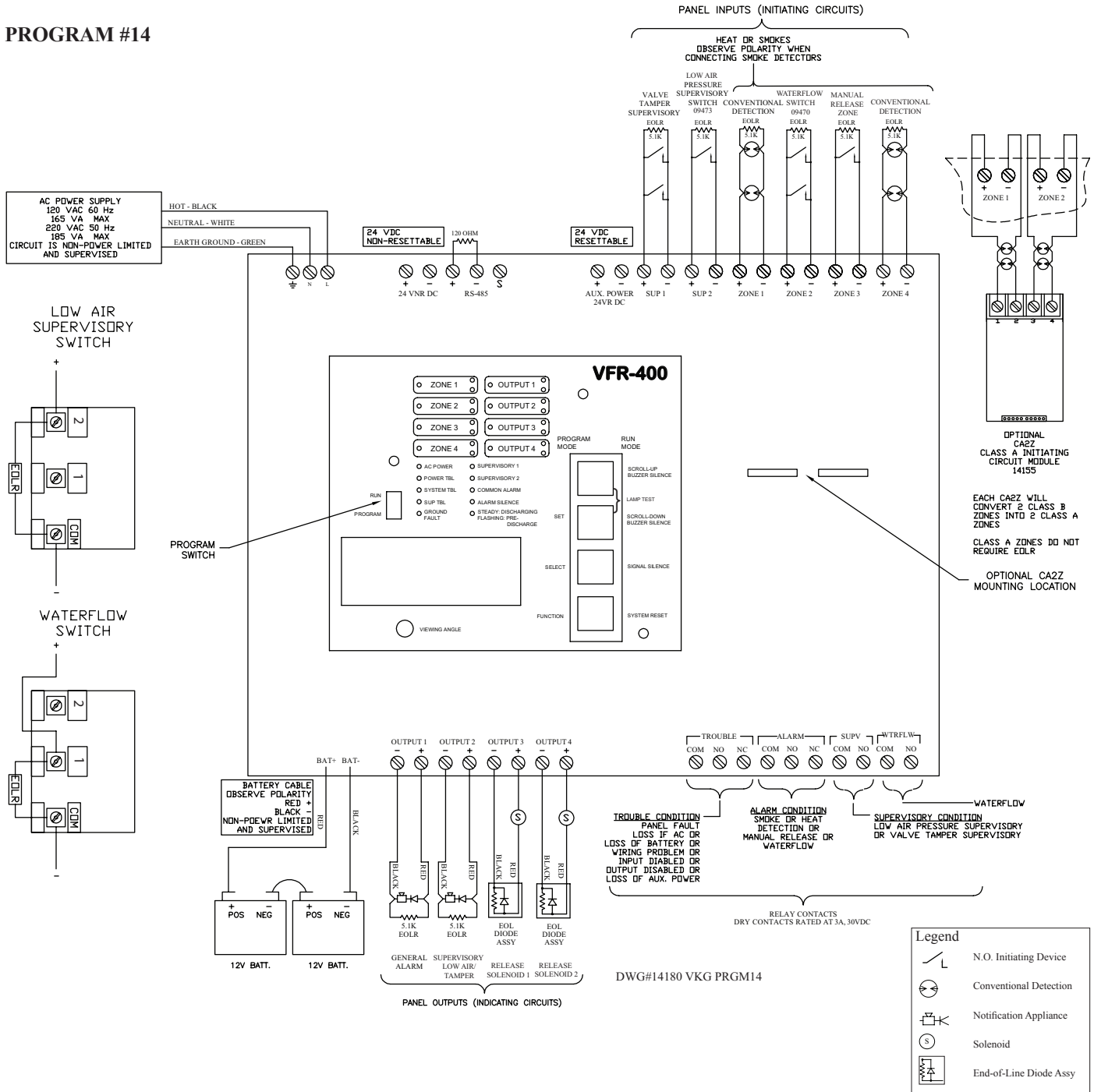

1. Run field wiring and ensure connections are proper by metering wires. Resistance reading should be 5.1K ohms with end-of-line resistor (EOLR) at last device. The end-of-line resistor is located on the mother board. Remove as needed. Leave factory installed EOLR on all unused circuits.
2. Connect one circuit at a time and apply AC power.
3. Connect batteries to the panel.
4. Once last connection is made, move Program switch down.
5. Press the FUNCTION (bottom) button until the display reads "PASSWORD = 000".
6. To enter a password, press the SELECT button until the proper number is displayed above the ^ symbol, then press the SET button to move to the next digit. After entering the third number the display will change. (All panels are shipped with a 000 password.)
7. Press the FUNCTION (bottom) button until the display reads "PROGRAM #X".
8. Press the SELECT button until the display reads "PROGRAM #14".
9. Press the SET button.
10. The panel is completely programmed except for the custom banner and zone messages. Move the program switch back up.

<b>PROGRAM #15</b>						
For One Sprinkler System						
Viking Sprinkler System Types (UK only)	2 Release Zones, Waterflow Zone, and Manual Release Zone	E-1 Single-interlocked Surefire preaction system with Electric-Pneumatic release				
OUTPUTS (Indicating Circuits)	ZONES (Initiating Circuits)					
	SUP 1	SUP 2	#1	#2	#3	#4
	Valve Tamper Supervisory Zone	Low Air Supervisory Zone	Conventional Detection Zone	Low Air Alarm Zone	Waterflow Zone	Manual Release Zone
#1 General Alarm			X		X	X
#2 Low air/Tamper	X	X		X		
#3 Release Solenoids #1 & #2			X			X
#4 N/O Solenoid				X		
OPERATION DESCRIPTION						
Inputs:	1 Conventional Detection zone, 1 Low air alarm zone, 1 Waterflow zone, 1 Manual Release zone, 2 Supervisory zones					
Outputs:	1 General Alarm, 1 Low Air/Tamper, 2 Release Solenoids (single output from panel), 1 N/O solenoid					
Operation:	Activation of Conventional Detection zone #1 or manual release zone #3 will activate output #3 (release solenoids) and output #1 (General Alarm)					
	Activation of Low Air Alarm zone #2 will activate output #2 Low air/tamper and output #4 (N/O solenoid)					
	Activation of Waterflow zone #3 will activate output #1 (General Alarm)					
	Activation of Valve Tamper supervisory zone #1, Low air supervisory zone #2, or Low Air alarm zone #2 will activate output #2 (Low Air/Tamper)					
	A trouble condition will prevent output #4 (N/O) from activating					

**NOTES:**

1. Connect EOL Diode assembly IN SERIES as shown with solenoids on outputs #3 and #4. Black wire to negative terminal on panel. Red wire through solenoid to positive terminal on panel. Output #3 has 2 solenoids. These must be connected in parallel and the EOL diode is connected in series with the parallel solenoids.
2. Polarity is shown on indicating/release circuits in an activated (in alarm) condition.
3. Leave EOLR (provided) on all unused circuits.
4. See the instruction manual for circuit information, panel limits, and battery sizing.
5. For wire routing instructions through the releasing panel, see Note 3 on page 17 of the instruction manual.
6. See instruction manual for proper programming.
7. See instruction manual for list of compatible smoke detectors and solenoids.
8. See specific system type data page for proper pressure switch settings.
9. Loss of power below 20 volts causes output #3 (release solenoids) and output #4 (N/O solenoid) to drop out.
10. See Viking technical data sheet F\_051604 for Surefire single interlock operation.

**PROGRAM #15**

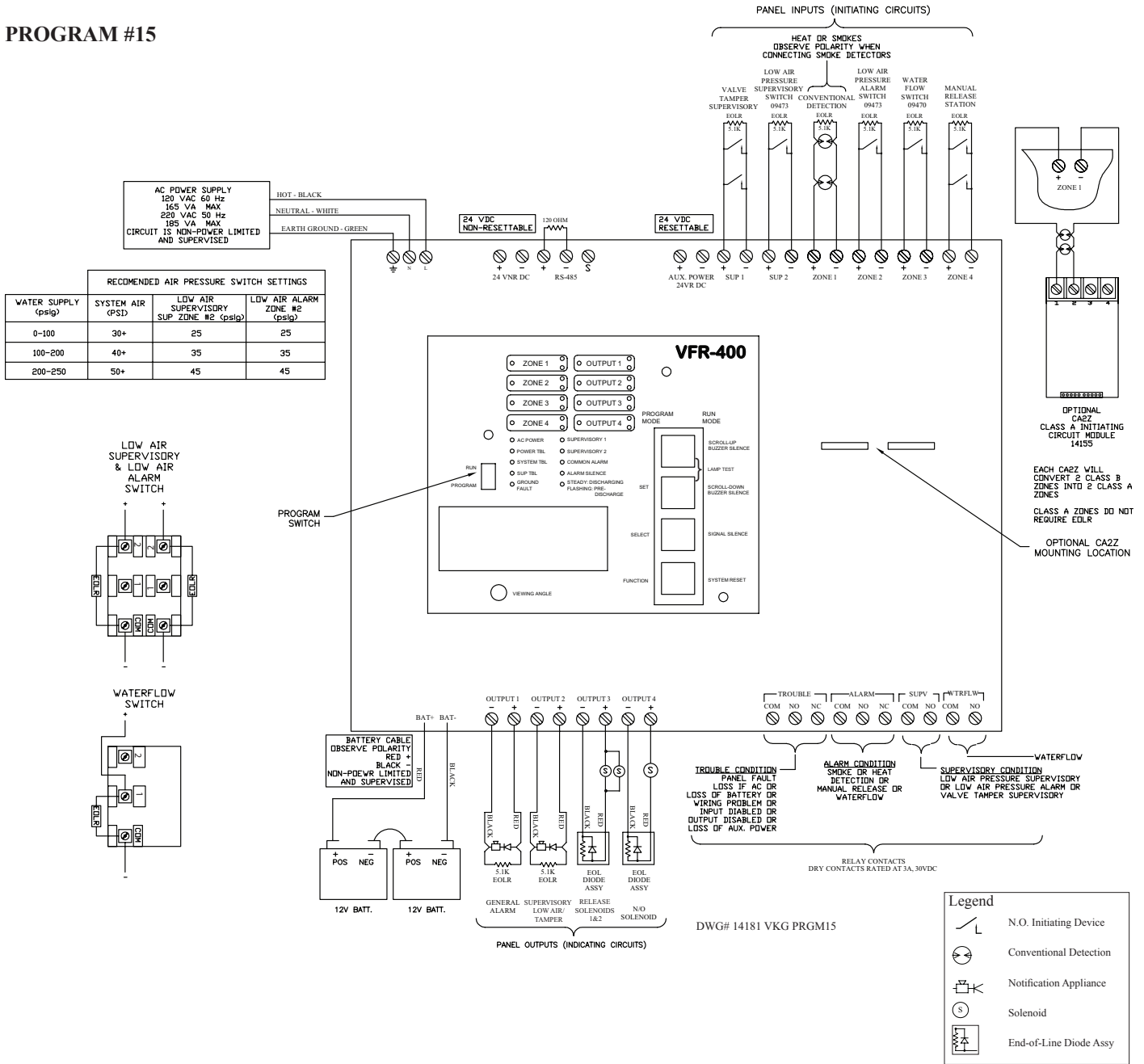

1. Run field wiring and ensure connections are proper by metering wires. Resistance reading should be 5.1K ohms with end-of-line resistor (EOLR) at last device. The end-of-line resistor is located on the mother board. Remove as needed. Leave factory installed EOLR on all unused circuits.
2. Connect one circuit at a time and apply AC power.
3. Connect batteries to the panel.
4. Once last connection is made, move Program switch down.
5. Press the FUNCTION (bottom) button until the display reads "PASSWORD = 000".
6. To enter a password, press the SELECT button until the proper number is displayed above the ^ symbol, then press the SET button to move to the next digit. After entering the third number the display will change. (All panels are shipped with a 000 password.)
7. Press the FUNCTION (bottom) button until the display reads "PROGRAM #X".
8. Press the SELECT button until the display reads "PROGRAM #15".
9. Press the SET button.
10. The panel is completely programmed except for the custom banner and zone messages. Move the program switch back up.

Note: Release solenoids #1 and #2 shall be wired in parallel and connected to output #3. the wiring shall be in conduit or otherwise protected. Any connections shall be made in a junction box. This may not conform to the monitoring for integrity requirements for NFPA 72.

<b>PROGRAM #16</b>						
For One Sprinkler System						
Viking Sprinkler System Types (UK only)	2 Release Zones, Waterflow Zone, and Manual Release Zone	E-1 Single-interlocked Firecycle III preaction system with Electric-Pneumatic release				
OUTPUTS (Indicating Circuits)	ZONES (Initiating Circuits)					
	SUP 1	SUP 2	#1	#2	#3	#4
	Valve Tamper Supervisory Zone	Low Air Supervisory Zone	Firecycle Detection Zone	Low Air Alarm Zone	Waterflow Zone	Manual Release Zone
#1 General Alarm			X		X	X
#2 Low air/Tamper	X	X		X		
#3 Release Solenoids #1 & #2			X			X
#4 N/O Solenoid			X	X	X	
OPERATION DESCRIPTION						
Inputs:	1 Firecycle Detection zone, 1 Low air alarm zone, 1 Waterflow zone, 1 Manual Release zone, 2 Supervisory zones					
Outputs:	1 General Alarm, 1 Low Air/Tamper, 2 Release Solenoids (single output from panel), 1 N/O solenoid					
Operation:	Activation of Firecycle Detection zone #1 will activate output #3 (release solenoids), output #1 (General Alarm), and output #4 (N/O solenoid)					
	Activation of Low air alarm zone #2 will activate output #2 (Low air/Tamper) and output #4 (N/O solenoid)					
	Activation of Waterflow Zone #3 will activate output #1 (General Alarm) and output #4 (N/O solenoid)					
	Activation of manual release zone #4 will activate output #3 (release solenoids) and output #1 (General Alarm)					
	Deactivation of the Firecycle Detector Zone #1 will start soak timer. When timer cycle is complete, output #3 (release solenoids) is deactivated.					
	Activation of Valve Tamper supervisory zone #1, Low air supervisory zone #2, or Low air alarm #2 will operate output #2 (Low air/Tamper)					

**NOTES:**

1. Connect EOL Diode assembly IN SERIES as shown with solenoids on outputs #3 and #4. Black wire to negative terminal on panel. Red wire through solenoid to positive terminal on panel. Output #3 has 2 solenoids. These must be connected in parallel and the EOL diode is connected in series with the parallel solenoids.
2. Polarity is shown on indicating/release circuits in an activated (in alarm) condition.
3. Leave EOLR (provided) on all unused circuits.
4. See the instruction manual for circuit information, panel limits, and battery sizing.
5. For wire routing instructions through the releasing panel, see Note 3 on page 17 of the instruction manual.
6. See instruction manual for proper programming.
7. See instruction manual for list of compatible smoke detectors and solenoids.
8. See specific system type data page for proper pressure switch settings.
9. Connect EOL resistor in SERIES after LAST Firecycle detector on return line to common terminal in Firecycle detector zone #1.
10. Set the soak timer to desired duration period. Factory setting is continuous. Recommended time is 60 seconds, minimum.
11. Loss of power below 20 volts causes output #3 (release solenoids) and output #4 (N/O solenoid) to drop out.
12. See Viking technical data sheet F\_051404 for Firecycle deluge multi-cycle system.

**PROGRAM #16**

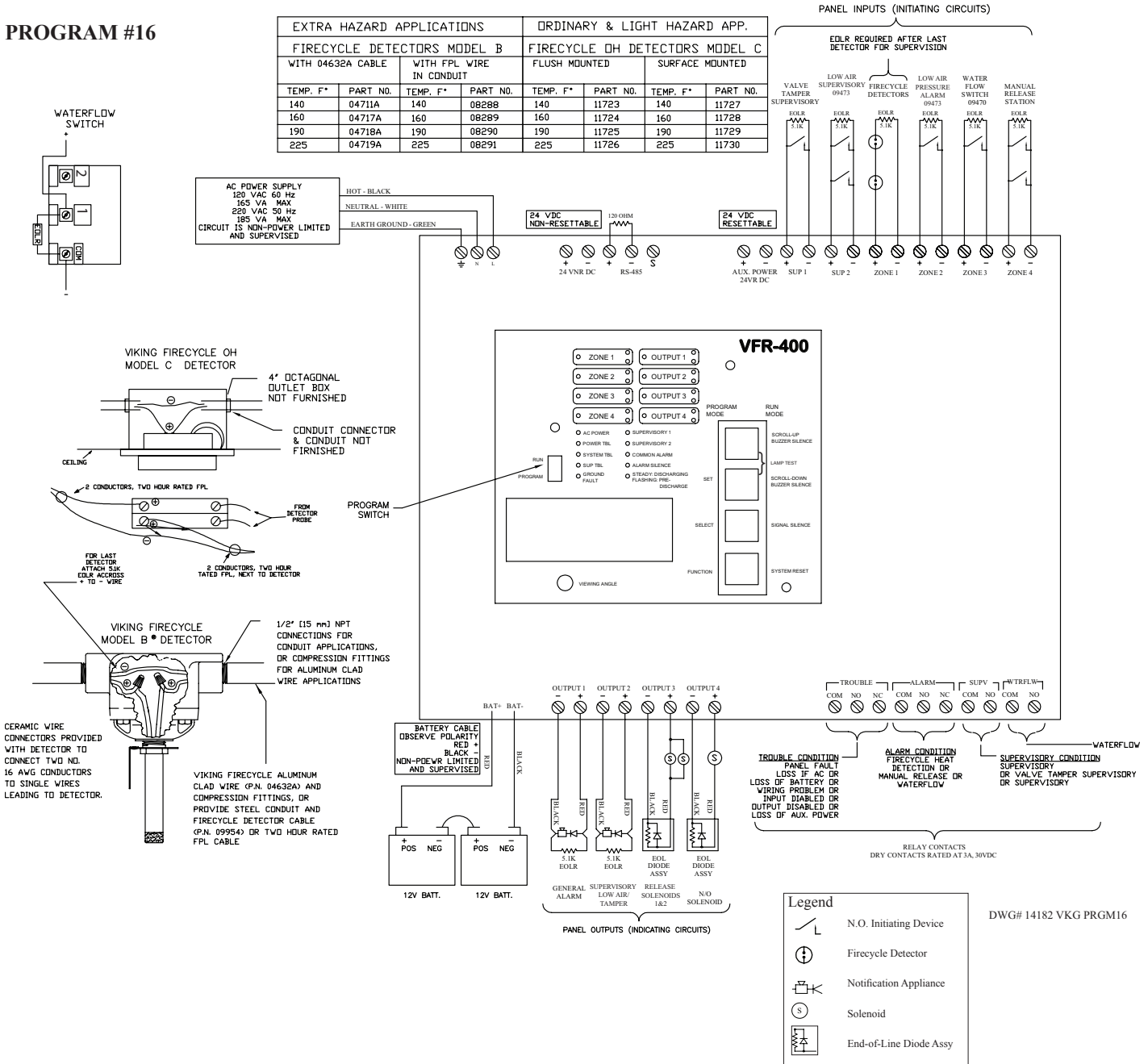

1. Run field wiring and ensure connections are proper by metering wires. Resistance reading should be 5.1K ohms with end-of-line resistor (EOLR) at last device. The end-of-line resistor is located on the mother board. Remove as needed. Leave factory installed EOLR on all unused circuits.
2. Connect one circuit at a time and apply AC power.
3. Connect batteries to the panel.
4. Once last connection is made, move Program switch down.
5. Press the FUNCTION (bottom) button until the display reads "PASSWORD = 000".
6. To enter a password, press the SELECT button until the proper number is displayed above the ^ symbol, then press the SET button to move to the next digit. After entering the third number the display will change. (All panels are shipped with a 000 password.)
7. Press the FUNCTION (bottom) button until the display reads "PROGRAM #X".
8. Press the SELECT button until the display reads "PROGRAM #16".
9. Press the SET button.
10. The panel is completely programmed except for the custom banner and zone messages. Move the program switch back up.

Note: Release solenoids #1 and #2 shall be wired in parallel and connected to output #3. the wiring shall be in conduit or otherwise protected. Any connections shall be made in a junction box. This may not conform to the monitoring for integrity requirements for NFPA 72.

**NOTICE**

The following programs are for chemical or gas extinguishing systems. Selecting the CHEMICAL mode allows the use of a pre-discharge timer and an abort circuit. The timer defaults to 60 seconds for all alarm zones programmed as other than MANUAL RELEASE. The MANUAL RELEASE default timer is 30 seconds. The system offers the programmer the ability to change the default timers to shorter times.

Systems intended for the release of Halon 1301 as described in NFPA 12A, or clean agents as described in NFPA 2001, shall have provision for a pre-discharge notification circuit. If this signal is required to be separate and/or distinct from the evacuation signal, two notification circuits are required. One shall be programmed as FIRST ALARM. It will provide a steady output upon activation of any initiating zone programmed as an alarm zone. This is the evacuation signal. If a temporal signal is required, notification appliances such as Potter H-1224 Select-A-Horn® or others that can produce a temporal tone shall be used. This allows the use of strobes and horns on the same circuit. The other notification circuit shall be programmed as SECOND ALARM. It will provide a steady output upon activation of a second initiating zone programmed as an alarm zone. This is when the pre-discharge timer would start and would be the pre-discharge signal. If a temporal signal is required, notification appliances such as Potter H-1224 Select-A-Horn® or others that can produce a temporal tone shall be used. This allows the use of strobes and horns on the same circuit. If a separate signal for discharge were required, a third notification circuit would be used that would be programmed to operate whenever the release circuit is activated.

Zones programmed as MANUAL RELEASE will activate outputs programmed as SECOND ALARM, even if the MANUAL RELEASE zone is the first alarm zone activated. SECOND ALARM is intended to be used as a pre-discharge signal for cross zone applications.



ZONES PROGRAMMED AS MANUAL RELEASE CANNOT BE ABORTED. IF IT IS NECESSARY TO ABORT A MANUAL RELEASE ZONE, THAT ZONE MUST BE PROGRAMMED AS DETECTION. IF THE PRE-DISCHARGE TIMER IS SET AT 0, THE ABORT CIRCUIT WILL NOT STOP THE RELEASE. NFPA 12 prohibits the use of abort circuits on suppression systems deploying carbon dioxide. Systems designed and installed in accordance with NFPA 2001 shall be provided with a mechanical manual release system.

**NOTE:**

On programs 20-24, the SUP 1/Abort zone defaults to Abort.

THIS PAGE INTENTIONALLY LEFT BLANK.

PROGRAM #20					
	ZONES				
	SUPERVISORY 2	#1	#2	#3	#4
OUTPUTS	Supervisory	Detection	Detection	Detection	Detection
#1 ALARM INDICATING		X	X		
#2 RELEASE		XX	XX		
#3 ALARM INDICATING				X	X
#4 RELEASE				XX	XX

OPERATION DESCRIPTION	
Description	Dual Hazard, 2 detection zones cross-zoned to 1 release circuit and 2 other detection zones cross zoned to another release circuit
Inputs	1 supervisory zone, 4 detection zones, 1 abort circuit
Outputs	2 general alarm, 2 release circuit
Operation	<p>Activation of either detection zones 1 and 2 will activate the alarm output #1                      Activation of both detection circuits at the same time will start the pre-discharge timer for release circuit output #2 as well as activate the alarm output #1                      Activation of either detection zones 3 and 4 will activate the alarm output #3                      Activation of both detection circuits at the same time will start the pre-discharge timer for release circuit output #4 as well as activate the alarm output #3</p> <p>When either zone 1 or 2 is in alarm, output 1 will operate                      When both zones 1 and 2 are in alarm at the same time, the pre-discharge timer for output #2 will operate                      When either zone 3 or 4 is in alarm, output 3 will operate                      When both zones 3 and 4 are in alarm at the same time, the pre-discharge timer for output #4 will operate</p>

**Program #20 Mode**

1. Apply power to panel.
2. Move the program switch down.
3. Press the FUNCTION (bottom) button until the display reads “PASSWORD = 000”.
4. To enter a password, press the SELECT button until the proper number is displayed above the ^ symbol, then press the SET button to move to the next digit. After entering the third number the display will change.  
(All panels are shipped with a 000 password.)
5. Press the FUNCTION (bottom) button until the display reads “PROGRAM #0”.
6. Press the SELECT button until the display reads “PROGRAM #20”.
7. Press the SET button.
8. Press the SELECT button to change the pre-discharge time.
9. Press the SET button to enter the pre-discharge time displayed.
10. Press the SELECT button to change the abort mode. See page 77 for abort mode selections.
11. Press the SET button to enter the abort mode displayed.
12. The panel is completely programmed except for the custom banner and zone messages Move the program switch back up.



# Wiring Diagram Program #20

Dual Hazard, 2 Detection Zones Cross-Zoned to 1 Release Circuit, 2 Other Detection Zones Cross-Zoned to A Separate Release Circuit, 1 Supervisory Zone, 1 Abort Circuit

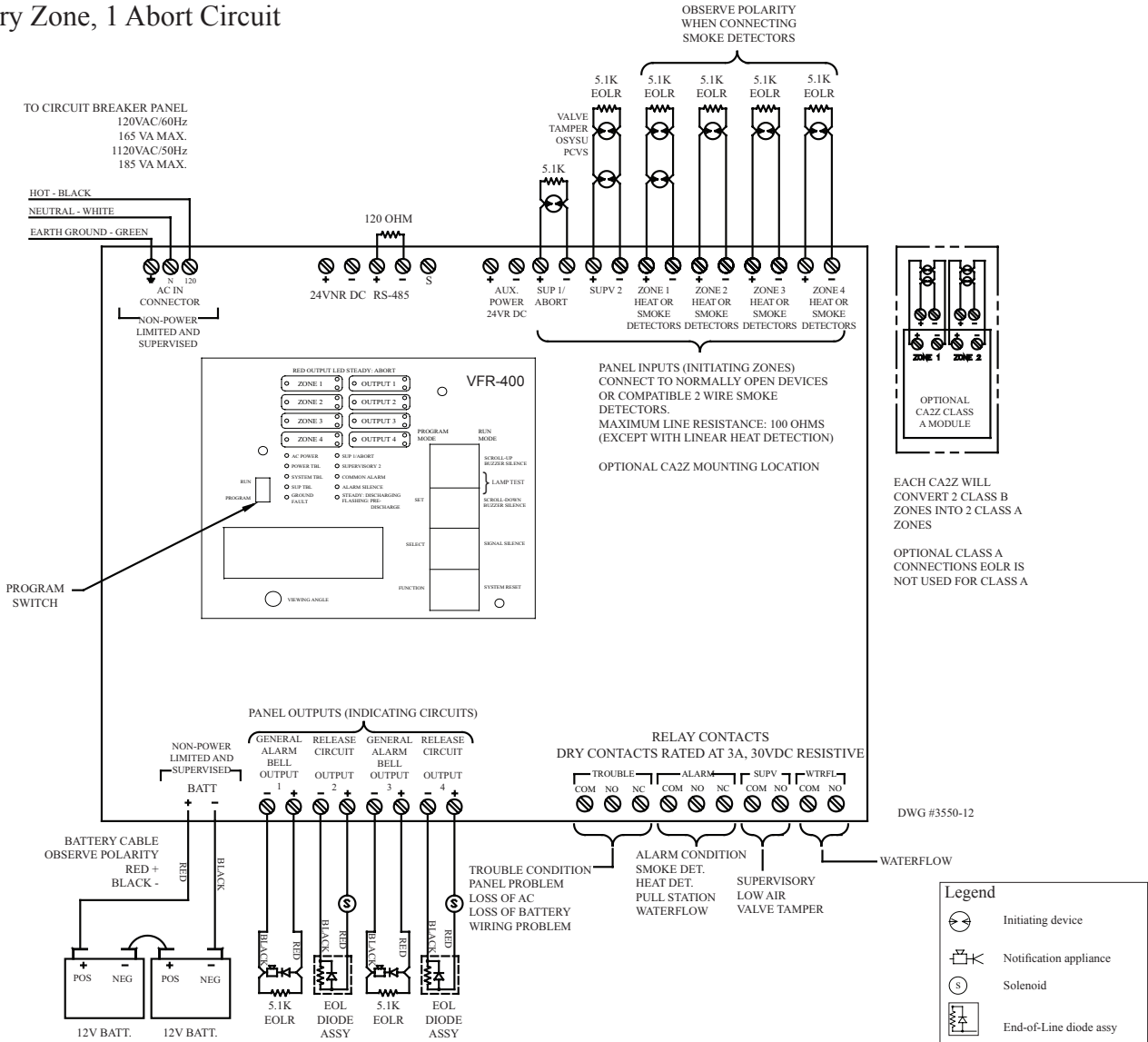

**NOTES:**

1. Connect only UL Listed 24VDC devices to indicating circuits.
  2. Connect EOL Diode assembly IN SERIES with solenoid on release circuit
  3. Leave EOLR (provided) on all unused circuits.
  4. Polarity is shown on indicating circuits in an activated (off-normal) condition.
  5. Polarity reverses when output is normal.
  6. Maximum current per output is 1 Amp. Maximum voltage is 33VDC.
  7. Maximum current for all four outputs combined is 2-1/2 Amps. All outputs are special application 24VDC.
  8. All initiating and NAC/Release circuits are supervised and power limited. See note 3 on page 17 for power limited wire routing instructions. All frequencies are continuous.
  9. Refer to pages 12-20 for installation, test and maintenance information.
  10. Maximum resistance on outputs is 10 ohms. Maximum resistance on outputs programmed as releasing, is 1 divided by current requirements of solenoid.
  11. Notification outputs do not provide synchronization. If synchronization is needed, refer to the NAC table on page 82. Synchronization is only on one circuit and not between circuits. The maximum cannot exceed 1 amp or whatever the maximum that the sync' module can support, whichever is lower.
- See page 80 or label inside panel door for smoke detector compatibility data.
- See pages 14-16 for battery information.

PROGRAM #21					
	ZONES				
	SUPERVISORY 2	#1	#2	#3	#4
OUTPUTS	Supervisory	Detection	Detection	Detection	Detection
#1 ALARM INDICATING		X	X		
#2 RELEASE		X	X		
#3 ALARM INDICATING				X	X
#4 RELEASE				X	X

SUP 1 defaults to abort

OPERATION DESCRIPTION	
Description	Dual Hazard, 2 detection zones mapped to 1 release circuit and 2 other detection zones mapped to another release circuit
Inputs	1 supervisory zone, 4 detection zones, 1 abort circuit
Outputs	2 general alarm, 2 release circuit
Operation	<p>Activation of either detection zone 1 or 2 will activate the alarm output #1 and start the pre-discharge timer for the release circuit output #2</p> <p>Activation of either detection zone 3 or 4 will activate the alarm output #3 and start the pre-discharge timer for the release circuit output #2</p> <p>When either zone 1 or 2 is in alarm, outputs 1 &amp; 2 will operate</p> <p>When either zone 3 or 4 is in alarm, outputs 3 &amp; 4 will operate</p>

**Program #21 Mode**

1. Apply power to panel.
2. Move the program switch down.
3. Press the FUNCTION (bottom) button until the display reads “PASSWORD = 000”.
4. To enter a password, press the SELECT button until the proper number is displayed above the ^ symbol, then press the SET button to move to the next digit. After entering the third number the display will change.  
(All panels are shipped with a 000 password.)
5. Press the FUNCTION (bottom) button until the display reads “PROGRAM #0”.
6. Press the SELECT button until the display reads “PROGRAM #21”.
7. Press the SET button.
8. Press the SELECT button to change the pre-discharge time.
9. Press the SET button to enter the pre-discharge time displayed.
10. Press the SELECT button to change the abort mode. See page 77 for abort mode selections.
11. Press the SET button to enter the abort mode displayed.
12. The panel is completely programmed except for the custom banner and zone messages. Move the program switch back up.

# Wiring Diagram Program #21

## Dual Hazard, 2 Detection Zones Mapped to 1 Release Circuit and 2 Other Detection Zones Mapped to A Separate Circuit, 1 Abort Circuit, and 1 Supervisory Circuit

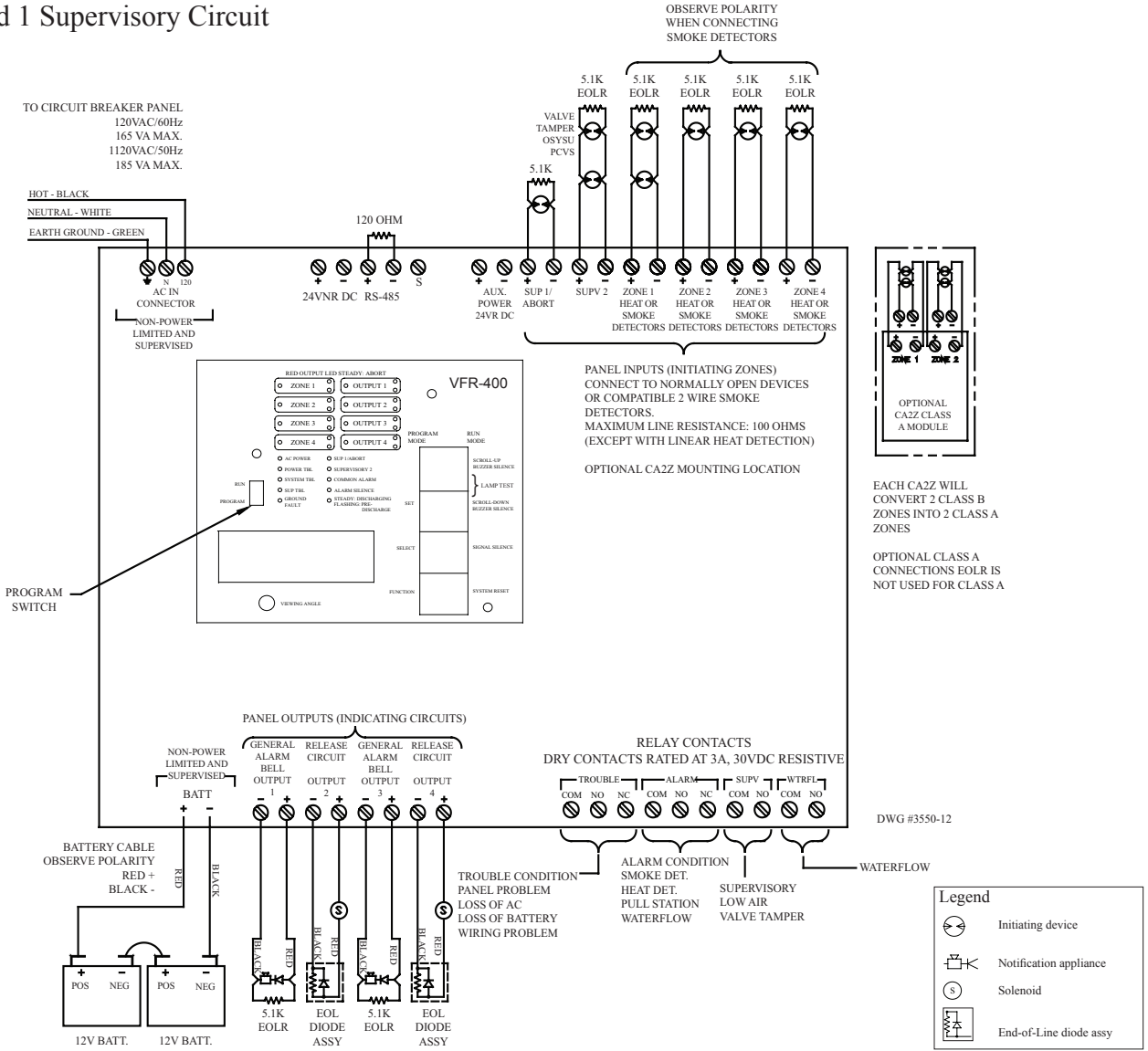

**NOTES:**

1. Connect only UL Listed 24VDC devices to indicating circuits.
  2. Connect EOL Diode assembly IN SERIES with solenoid on release circuit
  3. Leave EOLR (provided) on all unused circuits.
  4. Polarity is shown on indicating circuits in an activated (off-normal) condition.
  5. Polarity reverses when output is normal.
  6. Maximum current per output is 1 Amp. Maximum voltage is 33VDC.
  7. Maximum current for all four outputs combined is 2-1/2 Amps. All outputs are special application 24VDC.
  8. All initiating and NAC/Release circuits are supervised and power limited. See note 3 on page 79 for power limited wire routing instructions. All frequencies are continuous.
  9. Refer to pages 12-20 for installation, test and maintenance information.
  10. Maximum resistance on outputs is 10 ohms. Maximum resistance on outputs programmed as releasing, is 1 divided by current requirements of solenoid.
  11. Notification outputs do not provide synchronization. If synchronization is needed, refer to the NAC table on page 82. Synchronization is only on one circuit and not between circuits. The maximum cannot exceed 1 amp or whatever the maximum that the sync' module can support, whichever is lower.
- See page 80 or label inside panel door for smoke detector compatibility data.
- See pages 14-16 for battery information.

PROGRAM #22					
	ZONES				
	SUPERVISORY 2	#1	#2	#3	#4
OUTPUTS	Supervisory	Detection	Detection	Manual Release	Detection
#1 FIRST ALARM		X	X		
#2 SECOND ALARM		X	X	X	
#3 RELEASE		XX	XX	X	
#4 ALARM INDICATING					X

SUP 1 defaults to abort  
XX = Cross-Zoned

OPERATION DESCRIPTION	
Description	Single Hazard, 2 detection zones cross-zoned to 1 release circuit. A manual station zone and a discharge confirmation zone. Also first and second alarm notification circuits.
Inputs	1 supervisory zone, 3 detection zones, 1 manual station zone, 1 abort circuit
Outputs	3 general alarm, 1 release circuit
Operation	<p>Activation of either detection zones 1 or 2 will activate the alarm output #1                      Activation of both detection circuits at the same time will activate the alarm outputs #1, #2 and start the pre-discharge timer for the release circuit output #3                      Activation of the manual release zone #3 will activate the alarm output #2 and start the manual release pre-discharge timer for release circuit output #3                      Activation of zone 4 will operate output #4</p> <p>When either zone 1 or 2 is in alarm, output 1 will operate                      When both zones 1 and 2 are in alarm at the same time, outputs #1,2 will operate and the pre-discharge timer for output #3 will start                      When zone 3 is in alarm, output 2 will operate and the manual release pre-discharge timer for output #3 will start                      When zone 4 is in alarm, output #4 will operate</p>

**Program #22 Mode**

1. Apply power to panel.
2. Move the program switch down.
3. Press the FUNCTION (bottom) button until the display reads “PASSWORD = 000”.
4. To enter a password, press the SELECT button until the proper number is displayed above the ^ symbol, then press the SET button to move to the next digit. After entering the third number the display will change.  
(All panels are shipped with a 000 password.)
5. Press the FUNCTION (bottom) button until the display reads “PROGRAM #0”.
6. Press the SELECT button until the display reads “PROGRAM #22”.
7. Press the SET button.
8. Press the SELECT button to change the pre-discharge time.
9. Press the SET button to enter the pre-discharge time displayed.
10. Preset the SELECT button to change the manual release pre-discharge time. See page 77 for abort mode selections.
11. Press the SET button to enter the manual release pre-discharge time displayed.
12. Press the SELECT button to change the abort mode.
13. Press the SET button to enter the abort mode displayed.
14. The panel is completely programmed except for the custom banner and zone messages. Move the program switch back up.

# Wiring Diagram Program #22

## Single Hazard, 2 Detection Zones Cross-zoned to 1 Release Circuit, 1 Manual Station and A Discharge Confirmation Zone

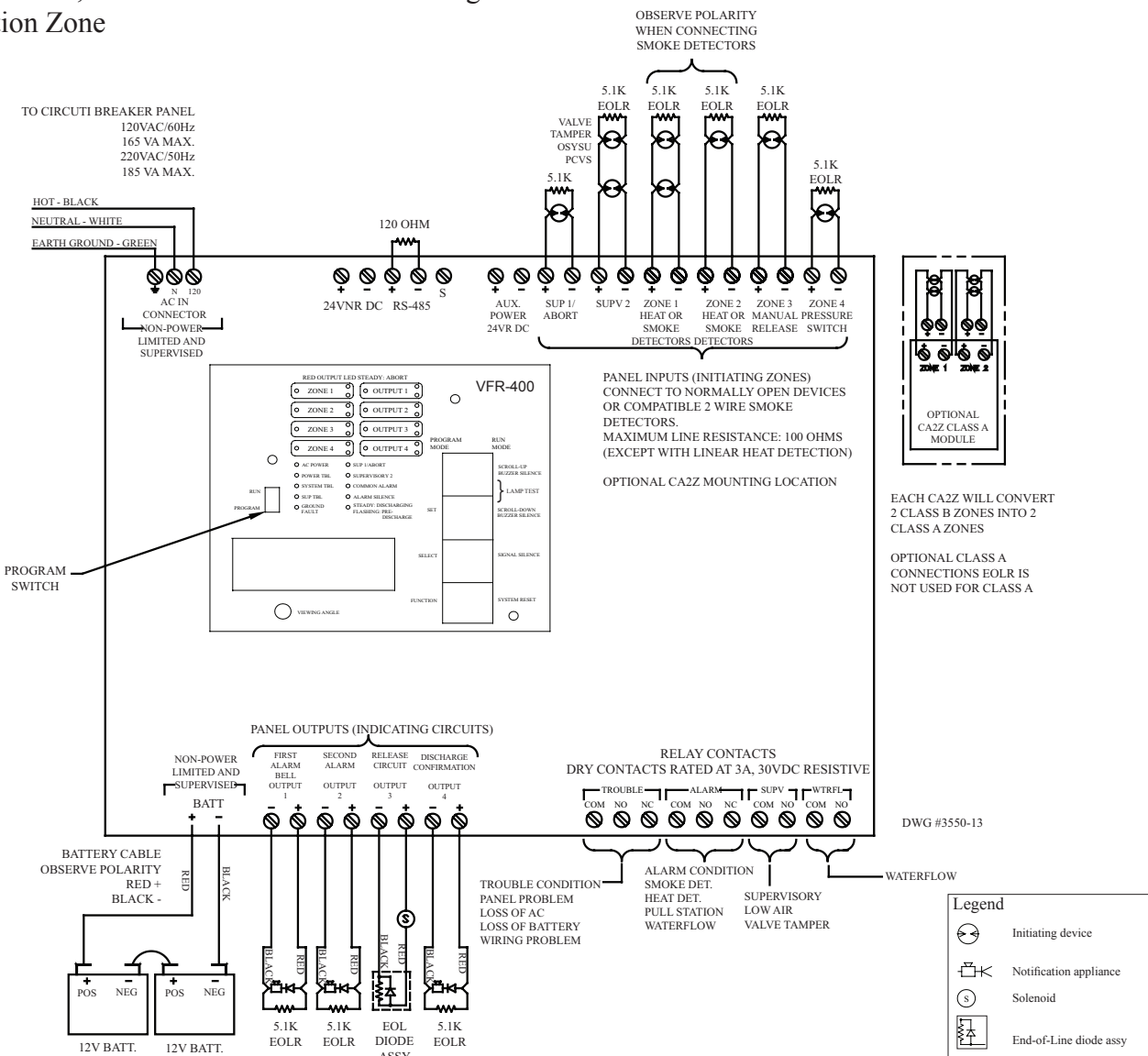

**NOTES:**

1. Connect only UL Listed 24VDC devices to indicating circuits.
  2. Connect EOL Diode assembly IN SERIES with solenoid on release circuit
  3. Leave EOLR (provided) on all unused circuits.
  4. Polarity is shown on indicating circuits in an activated (off-normal) condition.
  5. Polarity reverses when output is normal.
  6. Maximum current per output is 1 Amp. Maximum voltage is 33VDC.
  7. Maximum current for all four outputs combined is 2-1/2 Amps. All outputs are special application 24VDC.
  8. All initiating and NAC/Release circuits are supervised and power limited. See note 3 on page 17 for power limited wire routing instructions. All frequencies are continuous.
  9. Refer to pages 12-20 for installation, test and maintenance information.
  10. Maximum resistance on outputs is 10 ohms. Maximum resistance on outputs programmed as releasing, is 1 divided by current requirements of solenoid.
  11. Notification outputs do not provide synchronization. If synchronization is needed, refer to the NAC table on page 82. Synchronization is only on one circuit and not between circuits. The maximum cannot exceed 1 amp or whatever the maximum that the sync' module can support, whichever is lower.
- See page 80 or label inside panel door for smoke detector compatibility data.
- See pages 14-16 for battery information.

PROGRAM #23					
	ZONES				
	SUPERVISORY 2	#1	#2	#3	#4
OUTPUTS	Supervisory	Detection	Detection	Detection	Detection
#1 ALARM INDICATING		X	X	X	X
#2 TROUBLE					
#3 SUPERVISORY	X				
#4 RELEASE		X	X	X	X

SUP 1 defaults to abort

OPERATION DESCRIPTION	
Description	Single Hazard, 4 detection zones mapped to 1 release
Inputs	1 supervisory zone, 4 detection zones, 1 abort circuit
Outputs	1 general alarm, 1 trouble, 1 supervisory, 1 release circuit
Operation	<p>Activation of any detection zone will activate the alarm output #1 and start the pre-discharge timer for the release circuit output #4.</p> <p>Activation of the supervisory zone will operate the supervisory bell.</p> <p>A trouble condition (low battery, wire problem, etc.) will operate the trouble bell.</p> <p>When either zone 1, 2, 3, or 4 is in alarm, outputs 1 &amp; 4 will operate</p> <p>When the supervisory zone is activated - output #3 (supervisory bell) will operate.</p> <p>When the panel is in a trouble condition - output #2 (trouble bell) will operate.</p>

**Program #23 Mode**

1. Apply power to panel.
2. Move the program switch down.
3. Press the FUNCTION (bottom) button until the display reads “PASSWORD = 000”
4. To enter a password, press the SELECT button until the proper number is displayed above the ^ symbol, then press the SET button to move to the next digit. After entering the third number the display will change.  
(All panels are shipped with a 000 password.)
5. Press the FUNCTION (bottom) button until the display reads “PROGRAM #0”.
6. Press the SELECT button until the display reads “PROGRAM #23”.
7. Press the SET button.
8. Press the SELECT button to change the pre-discharge time.
9. Press the SET button to enter the pre-discharge time displayed.
10. Press the SELECT button to change the abort mode. See page 77 for abort selections.
11. Press the SET button to enter the abort mode displayed.
12. The panel is completely programmed except for the custom banner and zone messages. Move the program switch back up.

# Wiring Diagram Program #23

## Single Hazard, 4 Detection Zones Mapped to 1 Release Circuit, 1 Supervisory Zone, 1 Abort Circuit

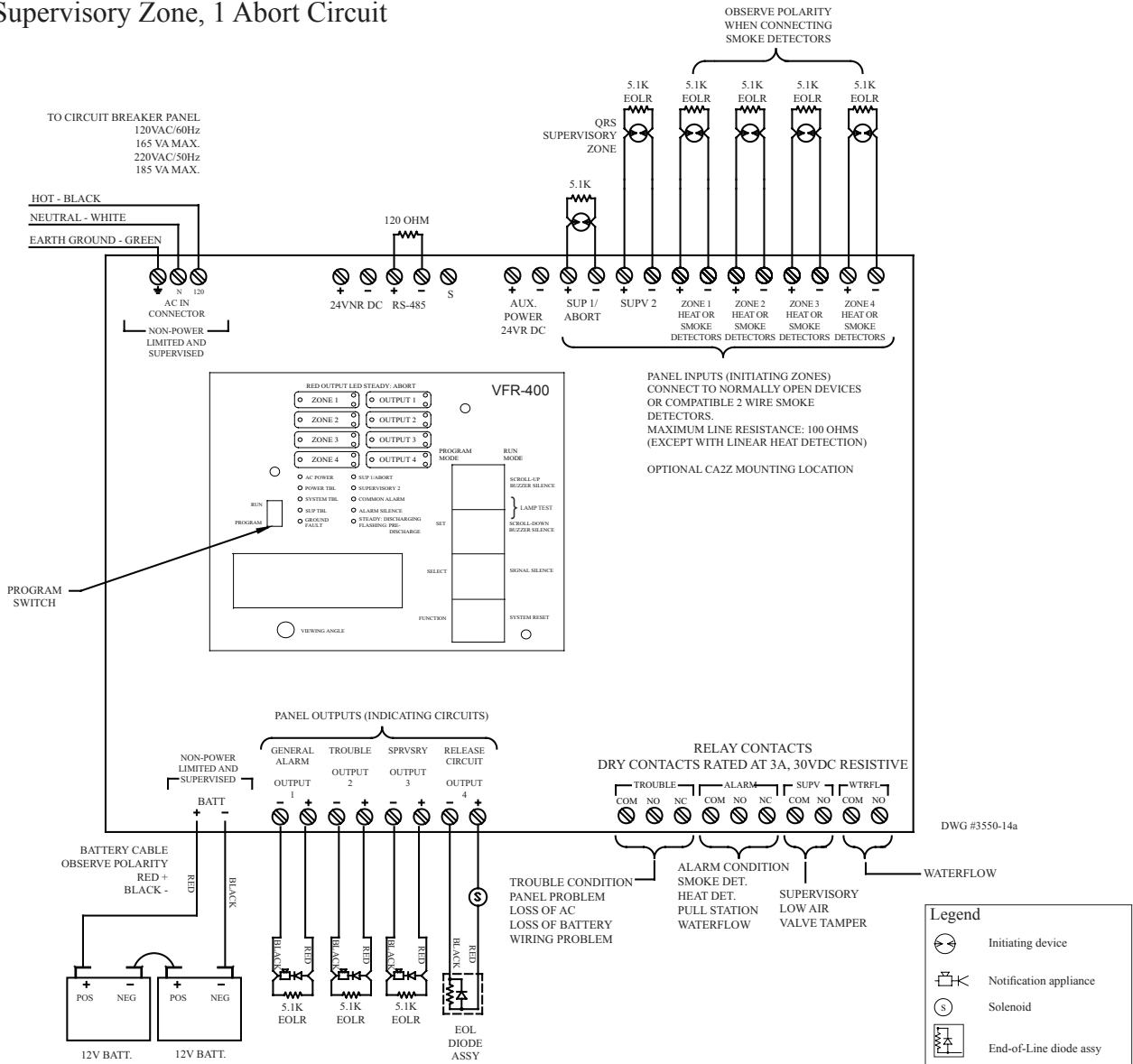

**NOTES:**

1. Connect only UL Listed 24VDC devices to indicating circuits.
  2. Connect EOL Diode assembly IN SERIES with solenoid on release circuit
  3. Leave EOLR (provided) on all unused circuits.
  4. Polarity is shown on indicating circuits in an activated (off-normal) condition.
  5. Polarity reverses when output is normal.
  6. Maximum current per output is 1 Amp. Maximum voltage is 33VDC.
  7. Maximum current for all four outputs combined is 2-1/2 Amps. All outputs are special application 24VDC.
  8. All initiating and NAC/Release circuits are supervised and power limited. See note 3 on page 17 for power limited wire routing instructions. All frequencies are continuous.
  9. Refer to pages 12-20 for installation, test and maintenance information.
  10. Maximum resistance on outputs is 10 ohms. Maximum resistance on outputs programmed as releasing, is 1 divided by current requirements of solenoid.
  11. Notification outputs do not provide synchronization. If synchronization is needed, refer to the NAC table on page 82. Synchronization is only on one circuit and not between circuits. The maximum cannot exceed 1 amp or whatever the maximum that the sync' module can support, whichever is lower.
- See page 80 or label inside panel door for smoke detector compatibility data.
- See pages 14-16 for battery information.

PROGRAM #24					
	ZONES				
	SUPERVISORY 2	#1	#2	#3	#4
OUTPUTS	Supervisory	Detection	Detection	Manual Release	Low Air
#1 ALARM INDICATING		X	X		
#2 ALARM INDICATING				X	
#3 RELEASE		X	X	X	
#4 SUPERVISORY	X				X

SUP 1 defaults to abort

OPERATION DESCRIPTION	
Description	Single Hazard, 2 detection zones, a manual station zone and a discharge confirmation zone.
Inputs	1 supervisory zone, 1 low air zone, 2 detection zones, 1 manual station zone, 1 abort circuit
Outputs	2 general alarm, 1 release circuit, 1 supervisory
Operation	<p>Activation of either detection zones 1 or 2 will activate the alarm output #1 and start the pre-discharge timer for the release circuit output #3                      Activation of the manual release zone #3 will activate the alarm output #2 and start the manual release pre-discharge timer for release circuit output #3                      Activation of zone 4 will operate output #4</p> <p>When either zone 1 or 2 is in alarm, output 1 will operate and the pre-discharge timer for output #3 will start                      When zone 3 is in alarm, output 2 will operate and the manual release pre-discharge timer for output #3 will start.                      When zone 4 is activated, output #4 will operate</p>

**Program #24 Mode**

1. Apply power to panel.
2. Move the program switch down.
3. Press the FUNCTION (bottom) button until the display reads “PASSWORD = 000”.
4. To enter a password, press the SELECT button until the proper number is displayed above the ^ symbol, then press the SET button to move to the next digit. After entering the third number the display will change.  
(All panels are shipped with a 000 password.)
5. Press the FUNCTION (bottom) button until the display reads “PROGRAM #0”.
6. Press the SELECT button until the display reads “PROGRAM #24”.
7. Press the SET button.
8. Press the SELECT button to change the pre-discharge time.
9. Press the SET button to enter the pre-discharge time displayed.
10. Press the SELECT button to change the manual release pre-discharge time. See page 77 for abort selections.
11. Press the SET button to enter the manual release pre-discharge time selected.
12. Press the SELECT button to change the abort mode.
13. Press the SET button to enter the abort mode displayed.
14. The panel is completely programmed except for the custom banner and zone messages. Move the program switch back up.



# Wiring Diagram Program #24 Single Hazard, 2 Detection Zones 1 Manual Station Zone and A Discharge Confirmation Zone

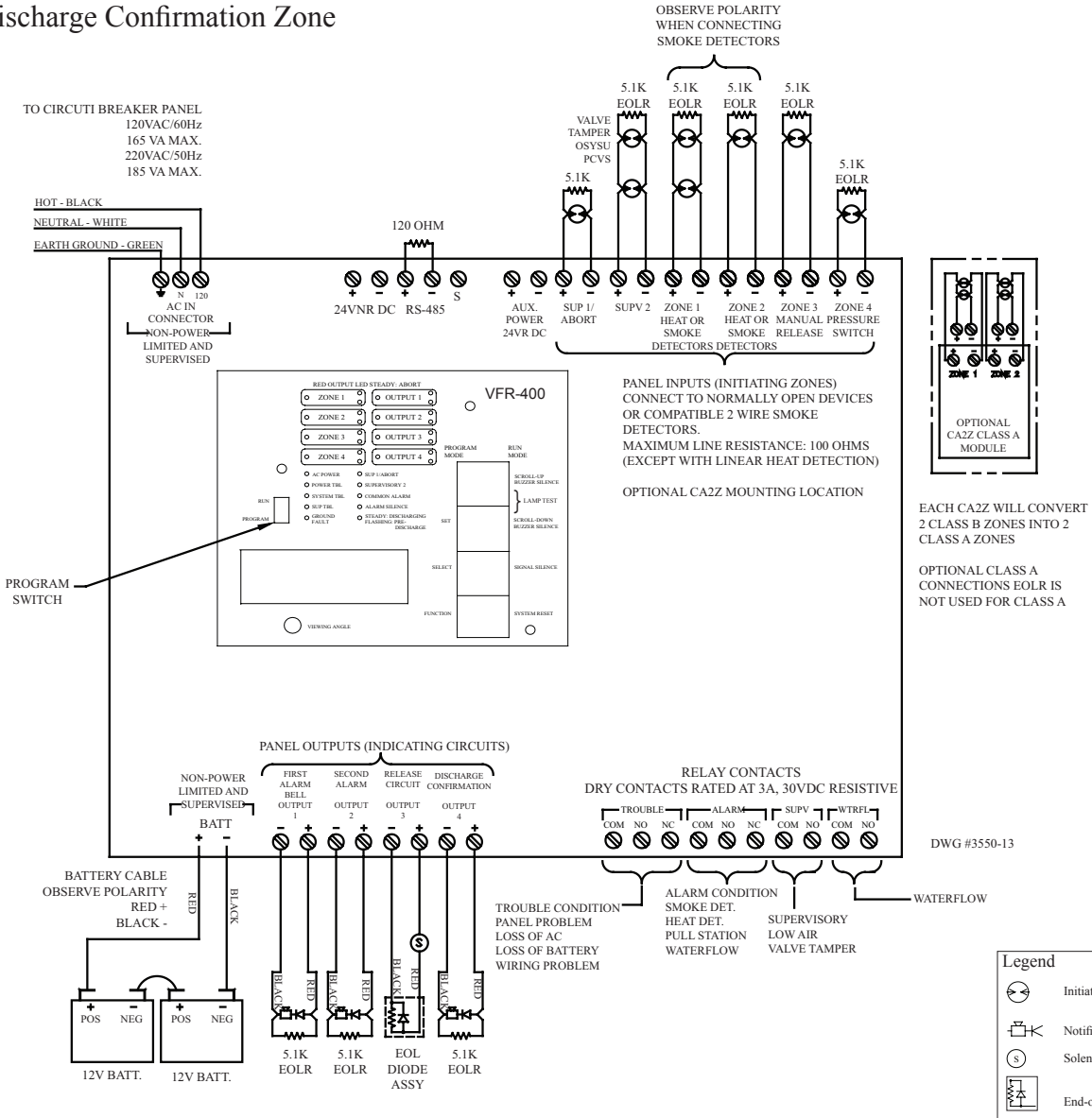

**NOTES:**

1. Connect only UL Listed 24VDC devices to indicating circuits.
2. Connect EOL Diode assembly IN SERIES with solenoid on release circuit
3. Leave EOLR (provided) on all unused circuits.
4. Polarity is shown on indicating circuits in an activated (off-normal) condition.
5. Polarity reverses when output is normal.
6. Maximum current per output is 1 Amp. Maximum voltage is 33VDC.
7. Maximum current for all four outputs combined is 2-1/2 Amps. All outputs are special application 24VDC.
8. All initiating and NAC/Release circuits are supervised and power limited. See note 3 on page 17 for power limited wire routing instructions. All frequencies are continuous.
9. Refer to pages 12-20 for installation, test and maintenance information.
10. Maximum resistance on outputs is 10 ohms. Maximum resistance on outputs programmed as releasing, is 1 divided by current requirements of solenoid.
11. Notification outputs do not provide synchronization. If synchronization is needed, refer to the NAC table on page 82. Synchronization is only on one circuit and not between circuits. The maximum cannot exceed 1 amp or whatever the maximum that the sync' module can support, whichever is lower.

See page 80 or label inside panel door for smoke detector compatibility data.

See pages 14-16 for battery information.

CUSTOM PROGRAM						
OUTPUTS	ZONES					
	SUP 1	SUP 2	#1	#2	#3	#4
#1						
#2						
#3						
#4						

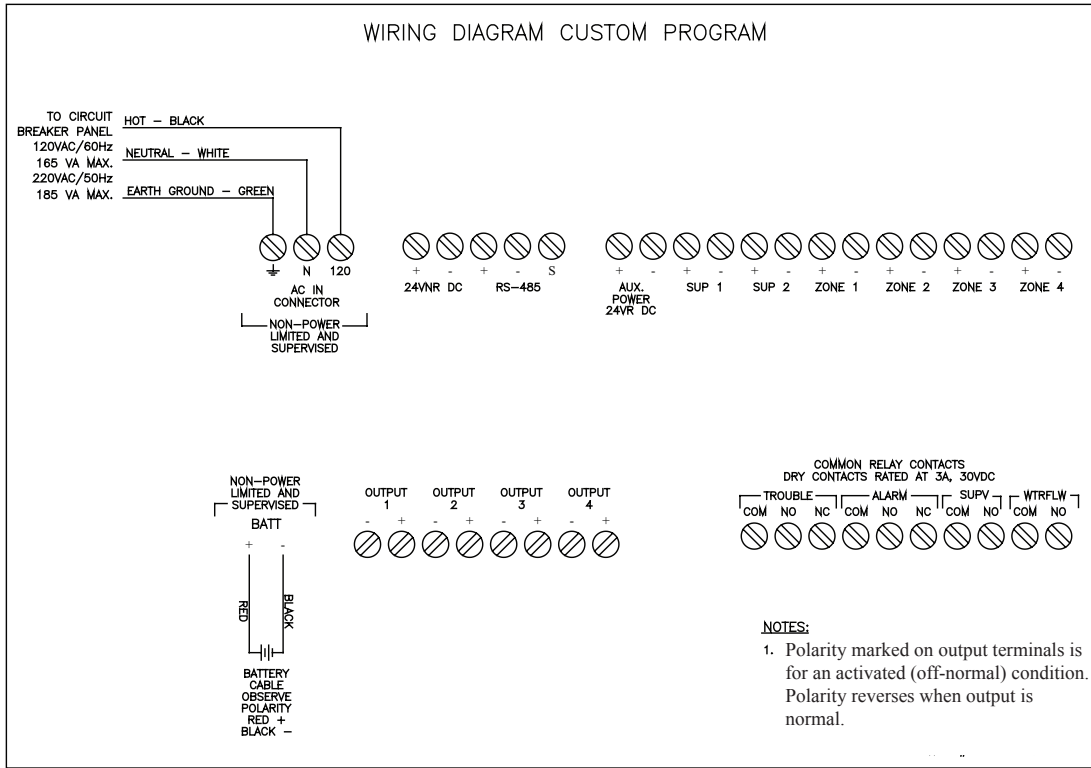

**Custom Program (#0 only)**

- Describe Initiating Zones 1 - 4

<b>Alarm Zones</b>	<b>Supervisory Zones</b>
Detection	Supervisory
Waterflow	Tamper
Linear Heat Detection	Low Air
Manual Release	High Air
Firecycle (Zone 1 only)	Low Air Alarm

- Describe Initiating dedicated Supervisory Zone (Sup 1 & Sup 2)

Supervisory
Tamper
Low Air
High Air

- Select Soak Timer

- Describe Output Zones

- Alarm Indicating
- Releasing
- Supervisory Bell
- Trouble Bell

- 1) Releasing circuits: normal/cross-zoned
- 2) Discharge time: 7, 8, 9, 10, 20 minutes or continuous

- Map Alarm Inputs to Outputs

- Put in Banner Message

- Put in Banner Message Bottom Line

- Put Zone Description for Each Initiating Zone

- Change Password

- Finished

### VFR-400 Custom Program Information For *Water Based Extinguishing Systems*

If the user has selected program # 0 for a custom configuration of the panel the following will appear in the display window.

P	R	O	G	R	A	M		T	Y	P	E	:			
W	A	T	E	R		B	A	S	E	D					

This display allows the user to select functions for either water or chemical based extinguishing systems. This window is for water based, to toggle from water based to chemical based or visa versa, press the SELECT (middle) button.

**SET**  Press the SET button to set the description displayed into the panels program

**SELECT**  Press the SELECT button to change the description displayed into the panels program

**FUNCTION**  Press the bottom button to skip to the next function

I	N	I	T		Z	O	N	E		#	1				
D	E	T	E	C	T	I	O	N							

#### Initiating Zone Description

This allows the user to describe the initiating zones. Ten different descriptions are available. They are:

1. FIRECYCLE - Used only with Normally Closed Firecycle® heat detectors. Automatic restoration of the Firecycle® heat detector will automatically start the Soak Timer.
2. DETECTION - These include smoke detectors, pull stations, heat detectors and other devices put on a conventional zone.
3. WATERFLOW - Alarms from waterflow zones are non-silenceable
4. LINEAR HEAT DETECTION - These use a special wire with a fuseable insulation
5. MANUAL RELEASE - Used to override cross zoning and cause instant release
6. LOW AIR ALARM – This is for a low air switch used in a double interlock system. Usually cross zoned with a smoke or heat detector. Activation of this zone creates a supervisory condition on the panel but can still operate the release circuit.
7. SUPERVISORY - For monitoring any supervisory function as assigned
8. TAMPER - For control valve monitoring
9. LOW AIR - Used to detect low air pressure
10. HIGH AIR - Used to detect high air pressure

The first five descriptions (FIRECYCLE, DETECTION, WATERFLOW, LINEAR HEAT DETECTION, and MANUAL RELEASE) are Alarm Zones. When activated, they will put the panel into alarm and operate the appropriate output as well as operating the alarm relay.

The 6<sup>th</sup> description (LOW AIR ALARM) creates a supervisory condition on the panel but can be used to activate the release circuit. This activates the Supervisory relay not the Alarm relay.

The last four descriptions (SUPERVISORY, TAMPER, LOW AIR and HIGH AIR) are Supervisory Zones. When activated, they will put the panel in a supervisory condition and activate any output described as “SUPERVISORY BELL”. They cannot activate the release circuit.

The 1st description (FIRECYCLE) is an automatically resettable alarm zone. The status of the zone follows the status of the FIRECYCLE heat detector. When the detector restores, the zone restores and initiates the soak timer.

**NOTE:** When FIRECYCLE is selected for zone 1, only outputs #3 and #4 can be mapped as releasing circuits.

If zone 1 is programmed as the FIRECYCLE, the following will appear in the display:

S	O	A	K		T	I	M	E	R						
C	O	N	T	I	N	U	O	U	S						

**Soak Timer Description**

This allows the user to select the amount of time the release circuit on output #3 will stay activated after the Firecycle zone restores to normal. The available times are 30, 60, 90 seconds, 2-20 minutes in 1 minute increments, or continuous.

After describing all initiating zones or skipping to the next function, the following will appear in the display window:

S	U	P	E	R	V	S	R	Y		1		Z	O	N	E
S	U	P	E	R	V	I	S	R	Y						

**SET**  Press the SET button to set the description displayed.

**SELECT**  Press the SELECT button to scroll through the five descriptions.  
(Supervisory, Valve Tamper, Low Air, High Air)

**FUNCTION**  Press the bottom button to skip to the next function.

After Selecting SUP 1, the following will appear in the display window.

S	U	P	E	R	V	S	R	Y		2		Z	O	N	E
S	U	P	E	R	V	I	S	R	Y						

**SET**  Press the SET button to set the description displayed.

**SELECT**  Press the SELECT button to scroll through the four supervisory descriptions.  
(Supervisory, Valve Tamper, Low Air, High Air)

**FUNCTION**  Press the bottom button to skip to the next function.

After describing what the supervisory zone is to be or skipping to the next function, the following will appear in the display window:

O	U	T	P	U	T		#	1							
I	N	D	I	C	A	T	I	N	G						

**Output Description**

This allows the user to describe the functions of the output circuits. Four descriptions are available:

- 1) ALARM INDICATING - Notification appliances include bells, horns, strobes and other appliances used to indicate an alarm.
- 2) RELEASING - Releasing appliances include solenoids and other electrically compatible devices.
- 3) SUPERVISORY BELL - Appliances on this circuit are used to indicate the presence of a supervisory condition. Any zone programmed as LOW AIR ALARM, SUPERVISORY, TAMPER, HI AIR or LOW AIR is automatically mapped to this output.
- 4) TROUBLE BELL - Appliances on this circuit are used to indicate the presence of a trouble condition.

The user should describe each output circuit in the same manner as the initiating circuit was described by pressing the SELECT button to select and the SET button to set the desired function.

**SET**  Press the SET button to set the description displayed.

**SELECT**  Press the SELECT button to scroll through the descriptions.

**FUNCTION**  Press the bottom button to skip to the next function.

After selecting all four outputs or pressing FUNCTION, the following will be displayed if any outputs have been described as RELEASING:

O	U	T	P	U	T		#	<	A	>				
N	O	R	M	A	L									

Where “<A>” is the number of the releasing circuit output.

**Normal/Cross-Zoning**

Each releasing circuit can be set up for the normal or cross zoned operation. In NORMAL operation, any alarm initiating zone including LOW AIR ALARM mapped to a releasing output must be in alarm before the output is activated. In cross zoned operation ALL initiating zones mapped to the releasing circuit must be in alarm before the output is activated. An initiating zone previously described as “MANUAL RELEASE” will override the cross zoning feature.

**SET**  Press the SET button to set the operation displayed.

**SELECT**  Press the SELECT button to toggle between NORMAL and CROSS ZONED.

**FUNCTION**  Press the bottom button to skip to the next function.

Z	O	N	E		1				V						
O	U	T	P	U	T	S	:		1		2		3		4

This display is where the outputs are mapped to the initiating zones. Any output that was previously described as “RELEASING” or “ALARM INDICATING” can be mapped to any initiating zones that were described as alarm zones, including zones programmed as “LOW AIR ALARM”.

Any initiating zone that was described as supervisory will automatically be mapped to outputs described as “SUPERVISORY BELL”, including zones programmed as “LOW AIR ALARM”. The “V” is pointing to the first available output for the zone indicated on the display. If the output number is displayed, it is turned on for that zone. If the number is not displayed, it is turned off. If an output is not available for that zone, i.e. “SUPERVISORY BELL”, the “V” will skip to the next available output.

**SET**  Press the SET button to set the output to the zone displayed and move to the next available output.

**SELECT**  Press the SELECT button to turn the output either on or off (the output number will be displayed when turned on).

**FUNCTION**  Press the bottom button to skip to the next function.

After all available outputs for the zone displayed are mapped, the display will automatically change to the next zone. After mapping the last zone or skipping to the next function, the following will appear in the display window:

B	A	N	N	E	R		M	E	S	S	A	G	E	?

**Custom Message**

To change the banner message, press the SELECT button. If you don't want to change the banner message press the bottom button.

**SET**

**SELECT**  Press the SELECT button to change banner message.

**FUNCTION**  Press the bottom button to skip to the next function.

If the SELECT button was pressed, the following will appear in the display window:

^															

The “^” is pointing to the first character on the top line. Press the SET button to scroll one direction through the character set, or press the SELECT button to scroll the other direction. The entire alphabet, numbers and punctuation are included.

**SET**  Press the SET button to scroll through the character set in one direction.

**SELECT**  Press the SELECT button to scroll in the opposite direction.

**FUNCTION**  Press the bottom button to enter the character displayed and to move to the next position.

After programming the top line (maximum 10 characters), continue this process for the bottom line and the initiating zones. To keep the initiating zones as “ZONE 1”, etc., press the bottom button when they are displayed. When finished with the last zone, the following will appear in the display window:

N	E	W		P	A	S	S	W	O	R	D	=	0	0	0
													^		

This allows the user to change the password. All panels are shipped from the factory with a password of 000.

**SET**  Press the SET button to set the displayed number and move to the next space.

**SELECT**  Press the SELECT button to scroll through the numbers.

**FUNCTION**  Press the bottom button to skip this function.

When finished with this section, the following will appear in the display window:

P	U	S	H		P	R	O	G	R	A	M	M	I	N	G
S	W	I	T	C	H		B	A	C	K		U	P		

**VFR400 Custom Program Information For Chemical Based Extinguishing Systems**

If the user has selected program # 0 for a custom configuration of the panel the following will appear in the display window.

P	R	O	G	R	A	M		T	Y	P	E	:			
W	A	T	E	R		B	A	S	E	D					

This display allows the user to select functions for either water or chemical based extinguishing systems. This window is for water based, to toggle from water based to chemical based or visa versa, press the SELECT (middle) button

**SET**  Press the top button to set the description displayed into the panels program

**SELECT**  Press the middle button to scroll between water or chemical based modes

**FUNCTION**  Press the bottom button to skip to the next function

After setting the CHEMICAL BASED mode or pressing FUNCTION, the following will appear in the display:

I	N	I	T		Z	O	N	E		#	1				
D	E	T	E	C	T	I	O	N							

**Initiating Zone Description**

This allows the user to describe the initiating zones. Nine different descriptions are available. They are:

- 1) DETECTION - These include smoke detectors, pull stations, heat detectors and other devices put on a conventional zone.
- 2) WATERFLOW - Alarms from waterflow zones are non-silenceable
- 3) LINEAR HEAT DETECTION - These use a special wire with a fuseable insulation
- 4) MANUAL RELEASE - Used to override cross zoning and cause instant release
- 5) LOW AIR ALARM – This is for a low air switch used in a double interlock system. Usually cross zoned with a smoke or heat detector. Activation of this zone creates a supervisory condition on the panel but can still operate the release circuit.
- 6) SUPERVISORY - For monitoring any supervisory function as assigned
- 7) TAMPER - For control valve monitoring
- 8) LOW AIR - Used to detect low air pressure
- 9) HIGH AIR - Used to detect high air pressure

The first four descriptions (DETECTION, WATERFLOW, LINEAR HEAT DETECTION and MANUAL RELEASE) are Alarm Zones. When activated, they will put the panel into alarm and operate the appropriate output as well as operating the alarm relay.

The 5<sup>th</sup> description (LOW AIR ALARM) creates a supervisory condition on the panel but can be used to activate the release circuit, this activates the Supervisory relay not the Alarm relay.

The last four descriptions (SUPERVISORY, TAMPER, LOW AIR and HIGH AIR) are Supervisory Zones. When activated, they will put the panel in a supervisory condition and activate any output described as “SUPERVISORY BELL”. They cannot activate the release circuit

**SET**  Press the SET button to set the description displayed.

**SELECT**  Press the SELECT button to scroll through the nine descriptions.

**FUNCTION**  Press the bottom button to skip to the next function.

After describing all initiating zones or skipping to the next function, the following will appear in the display window:

S	U	P	E	R	V	S	R	Y						Z	O	N	E
A	B	O	R	T													

Zone 5 is a supervisory or abort zone and can only be described as SUPERVISORY, TAMPER, LOW AIR or HIGH AIR, or ABORT.

**SET**  Press the SET button to set the description displayed.

**SELECT**  Press the SELECT button to scroll through the four supervisory and abort descriptions.

**FUNCTION**  Press the bottom button to skip to the next function.

S	U	P	E	R	V	S	R	Y		2		Z	O	N	E
S	U	P	E	R	V	I	S	R	Y						

Zone 6 is a supervisory zone and can only be described as SUPERVISORY, TAMPER, LOW AIR or HIGH AIR.

**SET**  Press the SET button to set the description displayed.

**SELECT**  Press the SELECT button to scroll through the four supervisory and abort descriptions.

**FUNCTION**  Press the bottom button to skip to the next function.

After describing what the supervisory zone is to be or skipping to the next function, the following will appear in the display window:

O	U	T	P	U	T		#	1							
I	N	D	I	C	A	T	I	N	G						

**Output Description**

This allows the user to describe the functions of the output circuits and whether they indicate first or second alarm, or release activated. Four descriptions are available:

- 1) ALARM INDICATING - Indicating appliances include bells, horns, strobes and other appliances used to indicate an alarm. These outputs are also programmable as first or second alarm when in chemical mode. The outputs programmed as first alarm will activate continuously upon activation of any alarm zone mapped to that output. Outputs programmed as second alarm will continue to operate in a continuous mode.
- 2) RELEASING - Releasing appliances include solenoids and other electrically compatible devices.
- 3) SUPERVISORY BELL - Appliances on this circuit are used to indicate the presence of a supervisory condition. Any zone programmed as LOW AIR ALARM, SUPERVISORY, TAMPER, HIGH AIR or LOW AIR is automatically mapped to this output.
- 4) TROUBLE BELL - Appliances on this circuit are used to indicate the presence of a trouble condition. The user should describe each output circuit in the same manner as the initiating circuit was described by pressing the middle button to select and the top button to set the desired function.

**SET**  Press the SET button to set the description displayed.

**SELECT**  Press the SELECT button to scroll through the descriptions.

**FUNCTION**  Press the bottom button to skip to the next function.



After selecting an output as INDICATING, a display similar to the following will appear:

O	U	T	P	U	T		#	<	a	>		I	N	D	
N	O	R	M	A	L										

Where “<a>” is the number of the indicating circuit output.

**First Or Second Alarm**

Each output programmed as INDICATING can be designated to operate on first or second alarm. First alarm is identified as NORMAL, second alarm is identified as 2ND ALARM. Any outputs programmed as INDICATING & NORMAL will operate when the zone they are mapped to is activated. Any output programmed as INDICATING & 2<sup>ND</sup> ALARM will operate when two or more zones mapped to it are activated. These outputs will operate in a continuous pattern even after the release circuit activates.

Zones programmed as MANUAL RELEASE will activate outputs programmed as SECOND ALARM, even if the MANUAL RELEASE zone is the first alarm zone activated. SECOND ALARM is intended to be used as a pre-discharge signal for cross zone applications. Refer to page 57 for a complete description of first and second alarm requirements and operation.

 <b>CAUTION</b>
An output programmed as INDICATING & 2nd ALARM that has only one initiating zone mapped to it will never operate. Likewise, if multiple zones are mapped to that output and only one zone activates, that output will not operate until another zone mapped to it activates.

**SET**  Press the SET button to set the description displayed.

**SELECT**  Press the SELECT button to scroll between NORMAL & 2ND ALARM

**FUNCTION**  Press the bottom button to skip to the next function.

After selecting all four outputs or pressing FUNCTION, the following will be displayed if any outputs have been described as RELEASING:

O	U	T	P	U	T		#	<	a	>					
N	O	R	M	A	L										

Where “<a>” is the number of the releasing circuit output.

**Normal/Cross-Zoning**

Each releasing circuit can be set up for the normal or cross zoned operation. In NORMAL operation, any alarm initiating zone including LOW AIR ALARM mapped to a releasing output must be in alarm before the output is activated. In cross zoned operation ALL initiating zones mapped to the releasing circuit must be in alarm before the output is activated. An initiating zone previously described as “MANUAL RELEASE” will override the cross zoning feature.

**SET**  Press the SET button to set the operation displayed.

**SELECT**  Press the SELECT button to toggle between NORMAL and CROSS ZONED.

**FUNCTION**  Press the bottom button to skip to the next function.

After selecting normal or cross zone operation the next function will be displayed as follows:

A	L		P	R	E	-	D	I	S	C	H	A	R	G	E
	0		S	E	C	O	N	D	S						

**Pre-discharge Timer for Alarm Zones**

A time delay of 0-60 seconds can be entered to delay the activation of the release circuit. The pre-discharge timer starts when all of the zones necessary for the operation of the release circuit have been activated. Pressing the middle button increases the time delay by one second. Pressing the middle button after 60 seconds is displayed will start the timer over at 0.

**SET**  Press the SET button to set the time displayed.

**SELECT**  Press the SELECT button to increase the time by one second.

**FUNCTION**  Press the bottom button to skip to the next function.

If a zone has not been programmed as MANUAL RELEASE, skip to the next programming step.

If a zone has been programmed as MANUAL RELEASE, the following will appear in the display window after choosing an alarm zone pre-discharge time:

M	R		P	R	E	-	D	I	S	C	H	A	R	G	E
	1		S	E	C	O	N	D	S						

**Pre-Discharge timer for MANUAL RELEASE zones**

A time delay of 0-30 seconds can be entered to delay the activation of the release circuit. The pre-discharge timer starts when the manual release zone has been activated. Pressing the middle button increases the time delay by one second. Pressing the middle button after 30 seconds is displayed will start the timer over at 0.

**SET**  Press the SET button to set the time displayed.

**SELECT**  Press the SELECT button to increase the time by one second.

**FUNCTION**  Press the bottom button to skip to the next function.

After choosing an alarm zone pre-discharge time, the following will appear in the display window:

A	B	O	R	T		T	Y	P	E	:					
U	L	I													

**Abort Modes**

The abort function is used to stop the release circuit from activating. Activation of the abort circuit will create a trouble condition.

- URI – Activation of the abort circuit stops the pre-discharge timer at 10 seconds. If there is less than 10 seconds remaining, the timer goes back to 10 seconds. Releasing the abort button restarts the timer at 10 seconds. Activate again to repeat.
- IRI – This mode, only functions if the release circuit is cross zoned. The IRI mode has the same functions as the ULI mode except the abort button must be pressed and held before the second zone necessary for the activation of the release circuit goes into alarm. Activation of the abort after the second alarm is received will have no effect. If the release circuit is not cross zoned, operation of the abort circuit in the IRI mode will not stop the release circuit.
- NYC – This mode is not UL listed. This is a one shot function. Activation of the abort circuit will add 90 seconds to the original pre-discharge time. The countdown with the additional 90 seconds will begin when the abort button is released. Pressing the abort button again will have no effect.
- 30-Second Abort – Activation of the abort circuit will stop the pre-discharge timer at 30 seconds. If there is less than 30 seconds remaining, the timer goes back to 30 seconds. Releasing the abort button re-starts the timer. Activate again to repeat.

## **WARNING**

- \*The abort zone is a non-latching zone. In order for the abort function to operate, the abort button must be pressed and held continuously. Releasing the abort button will continue the pre-discharge timer.
- \*The abort function will not prevent the activation of the release circuit if a zone programmed as MANUAL RELEASE has been activated. MANUAL RELEASE always overrides the abort function.
- \*The abort function will not prevent the activation of the release circuit if there is no pre-discharge time set or if the pre-discharge time is 1 second or less when the abort button is pressed.

The next function will be displayed as follows:

D	I	S	C	H	A	R	G	E		T	I	M	E		
C	O	N	T	I	N	U	O	U	S						

### Releasing Output Time

This allows the user to determine how long the releasing circuit is energized upon alarm. The available times are 7, 8, 9, 10, 20 minutes and continuous. Use the middle button to scroll through the possible options and the top button to set that option. Press the bottom button to skip to the next function.

**SET**  Press the SET button to set the time displayed.

**SELECT**  Press the SELECT button to scroll through the available time.

**FUNCTION**  Press the bottom button to skip to the next function.

After a discharge time is entered, a display similar to the following will appear:

Z	O	N	E		1			V							
O	U	T	P	U	T	S	:		1		2		3		4

This display is where the outputs are mapped to the initiating zones. Any output that was previously described as “RELEASING” or “ALARM INDICATING” can be mapped to any initiating zones that were described as alarm zones, including zones programmed as LOW AIR ALARM. Any initiating zone that was described as supervisory will automatically be mapped to outputs described as “SUPERVISORY BELL”, including zones programmed as LOW AIR ALARM. The “v” is pointing to the first available output for the zone indicated on the display. If the output number is displayed, it is turned on for that zone. If the number is not displayed, it is turned off. If an output is not available for that zone, i.e. “SUPERVISORY BELL”, the “v” will skip to the next available output.

**SET**  Press the SET button to set the output to the zone displayed and move to the next available output.

**SELECT**  Press the SELECT button to turn the output either on or off (the output number will be displayed when turned on).

**FUNCTION**  Press the bottom button to skip to the next function.

After all available outputs for the zone displayed are mapped, the display will automatically change to the next zone. After mapping the last zone or skipping to the next function, the following will appear in the display window:

B	A	N	N	E	R		M	E	S	S	A	G	E	?	
C	U	S	T	O	M		M	E	S	S	A	G	E		

To change the banner message, press the SET or SELECT buttons. If you don't want to change the banner message press the bottom button.

If the SET or SELECT button was pressed, the following will appear in the display window:

^																			

The “^” is pointing to the first character on the top line. Press the top button to scroll one direction through the character set, or press the middle button to scroll the other direction. The entire alphabet, numbers and punctuation are included.

**SET**  Press the SET button to scroll through the character set in one direction.

**SELECT**  Press the SELECT button to scroll in the opposite direction.

**FUNCTION**  Press the bottom button to enter the character displayed and to move to the next position.

After programming the top line (maximum 10 characters), continue this process for the bottom line and the initiating zones. To keep the initiating zones as “ZONE 1”, etc., press the bottom button when they are displayed.

When finished with the last zone, the following will appear in the display window:

N	E	W		P	A	S	S	W	O	R	D	=	0	0	0
													^		

This allows the user to change the password. All panels are shipped from the factory with a password of 000.

**SET**  Press the SET button to set the displayed number and move to the next space.

**SELECT**  Press the SELECT button to scroll through the numbers.

**FUNCTION**  Press the bottom button to skip this function.

When finished with this section, the following will appear in the display window:

P	U	S	H		P	R	O	G	R	A	M	M	I	N	G
S	W	I	T	C	H		B	A	C	K		U	P		

Quit by returning the programming switch to the left position. The panel is now ready for operation.

**Programming Summary**

- Examine History Buffer
- Set Time
- Enter Password
- Enable/Disable Initiating Zones
- Enable/Disable Output Zones
- System Mode - Normal/One Man Walktest
- Select Program - #0 thru #24

**2-WIRE SMOKE DETECTOR AND SYNCHRONIZATION MODULE COMPATIBILITY DATA**  
**Smoke Detector Compatibility Identifier “A”**

**System Sensor (Brk) (Max. No. Of Detectors Per Zone Is 20)**

Det. Model	Identifier	Base Model	Identifier
1400*	A	N/A	N/A
2400*	A	N/A	N/A
2400TH*	A	N/A	N/A
2W-B	A	N/A	N/A
2WT-B	A	N/A	N/A
2WTR-B	A	N/A	N/A

**Detection Systems (Max. No. Of Detectors Per Zone Is 25)**

Det. Model	Identifier	Base Model	Identifier
DS250	A	MB2W/MB2WL	A
DS250TH	A	MB2W/MB2WL	A
DS250HD	A	MB2W/MB2WL	A

**ESL (Max. No. Of Detectors Per Zone Is 25)**

Det. Model	Identifier	Base Model	Identifier
611U	S10	601U	S00
611UD	S10	601U	S00
611UT	S10	601U	S00
612U	S10	601U	S00
612UD	S10	601U	S00
613U5	S10	601U	S00
611UD	S10	609U10	S00
612UD	S10	609U10	S00
425C	S10	N/A	N/A
425CT	S10	N/A	N/A

**Hochiki (Max. No. Of Detectors Per Zone Is 25)**

Det. Model	Identifier	Base Model	Identifier
SLR-24*	HD-3	HSC-221R	HB-71
		HSB-221	HB-54
		HSB-221N	HB-54
		NS6-221	
		NS4-221	
SLR-24H*	HD-3	HSC-221R	HB-71
		HSB-221	HB-54
		HSB-221N	HB-54
		NS6-221	
		NS4-221	
SIJ-24*	HD-3	HSC-221R	HB-71
		HSB-221	HB-54
		HSB-221N	HB-54
		NS6-221	
		NS4-221	

**Fenwal (Max. No. Of Detectors Per Zone Is 25)**

Det. Model	Identifier	Base Model	Identifier
CPD-7051*	I51FE1	2-WIRE	FE51A
PSD-7155*	P55FE1	2WRLT	FE52A
PSD-7156*	P56FE1	2WRB	FE55A

All of the above Fenwal detectors and bases can be used in any combination

Retrofit Base Adaptor 70-501000-003, Identifier MAFE1 (for series 70-201000 Bases, Models -001, -002, -003 and -005)

Duct Housing with Detector Base DH-51, Identifier DH22FE5 (for CPD-7051 and PSD-7155 detectors only)

**Potter (Max. No. Of Detectors Per Zone Is 25)**

Det. Model	Identifier	Base Model	Identifier
PS-24*	HD-3(HOCHIKI)	SB-46	HB-71(HOCHIKI) HB-54(HOCHIKI)
PS-24H	HD-3(HOCHIKI)	SB-46	HB-71(HOCHIKI) HB-54(HOCHIKI)
IS-24*	HD-3(HOCHIKI)	SB-46	HB-71(HOCHIKI) HB-54(HOCHIKI)

**NOTICE**

Only one detector can be supported in alarm per zone.  
 \*UL and ULC Listed

If using a mix of System Sensor and other smoke detectors, a maximum of 20 detectors shall be permitted.

Sync Modules: Amseco - SMD10-3A      Gentex - AVSM      System Sensor - MDL      Wheelock - DSM 12/24

**4-WIRE HEAT DETECTOR COMPATIBILITY IDENTIFIER “A”**

Viking Firecycle normally closed heat detectors

**RELEASING DEVICE COMPATIBILITY**

Automatic Water Control Valves Compatibility Data
(One solenoid per circuit)
Viking:
11591 Normally closed
11601 Normally closed
11602 Normally closed, explosion-proof
11595 Normally open
11596 Normally open, explosion-proof
E-1

**AGENT RELEASING SYSTEMS COMPATIBILITY**

Manufacturer	Actuator	Voltage
MiniMax	MX1230 and MX200 with Minimax actuator 887667 and 889323	24VDC
Viking	VK1230 and VK200 with actuator 16360	24VDC

**NAC COMPATIBILITY CHART**

Manufacturer	Model #	Type Of Device	Maximum Devices Per Circuit*
Potter/Amseco All devices compatible with SMD10-3A	SL24W-1530	Strobe	7 to 11
	SH24W-1530	Horn/Strobe	6 to 9
	MBA 24-6	Bell	16
	MBA 24-8	Bell	16
	MBA 24-10	Bell	16
	MH-12/24	Mini-Horn	66
	HP-25T	Mini-Horn	60
	CSL24W	Strobe	7 to 12 (Not for Evacuation)
	CSL24C	Strobe	4 to 8 (Not for Evacuation)
	CSH24W	Horn/Strobe	6 to 9 (Not for Evacuation)
	CSH24C	Horn/Strobe	3 to 7 (Not for Evacuation)
	H24W	Horn	14
	CM24W	Chime	22
	CSHB24	Horn/Strobe	5 (Not for Evacuation)
	CSLB24	Strobe	6 (Not for Evacuation)
	SMD10-3A	Sync Module	1
Gentex All devices Compatible with AVSM	GEH	Horn	35
	GEC3	Horn/Strobe	3 to 10
	AVSM	Sync Module	1
System Sensor All devices compatible with the MDL	H SERIES	Horn	14
	S SERIES	Strobe	3 to 15
	MH Series	Mini-Horn	12
	SSM24-6	Bell	18
	SSM24-8	Bell	18
	SSM24-10	Bell	18
	MDL	Sync Module	1
Wheelock All device are compatible with the DSM	RSS/RSSP	Strobe	11
	AS-241575	Horn/Strobe	6
	AS-24MCW	Horn/Strobe	3 to 11
	AS-24MCWH	Horn/Strobe	2
	NS-24MCW	Horn/Strobe	4 to 15
	NS-241575	Horn/Strobe	9
	NS-24MCC/ MCCH	Horn/Strobe	2 to 14
	MT-241575	Horn/Strobe	3 to 11
	MT-24MCW	Horn/Strobe	3 to 11
	AMT-241575	Horn/Strobe	4 to 9
	AMT-24MCW	Horn/Strobe	3 to 12
	AMT 12/24	Horn	8 to 17
	NH-12/24	Horn	22 to 55
	HS-24	Horn	37
	HS4-241575	Horn/Strobe	5 to 8
	HS4-24MCW	Horn/Strobe	3 to 11
	HS4-24MCC	Horn/Strobe	2 to 10
	MT-12/24	Horn	16 to 66
	AH-24	Horn	12 to 47
	MIZ	Mini-Horn	38
	ASWP	Horn/Strobe	6
	DSM	Sync Module	1

\* Number of devices per circuit will depend on the field selectable candela and audible settings of the device.

**4-WIRE SMOKE DETECTORS/DEVICES**

<b>Smoke Detector</b>	<b>Detector Type</b>	<b>Standby Current (mA)</b>	<b>Alarm Current (mA)</b>
Potter PS-24*	Photoelectric	.045	150
Potter PS-24H*	Photoelectric/Heat	.045	150
Potter IS-24*	Ionization	.040	150
DSD-P	Photoelectric Duct	.390	8
Hochiki SLR-835*	Photoelectric	.055	150
Hochiki SLR-835H	Photoelectric/Heat	.045	150
Hochiki SLR-24V*	Photoelectric	.045	150
Hochiki SLR-24VN*	Photoelectric	.045	150
Hochiki SIJ-24*	Ionization	.040	150
Hochiki DCD-135/190	Heat	.040	150
Hochiki DH-98	Photoelectric Duct	.390	8
Hochiki SPB-24	Beam	.25	**
Fenwal CPD-7021 (w/70-201000-005 base)	Ionization	0.10	**
Fenwal PSD-7125	Photoelectric	0.10	**
Fenwal PSD-7126 (w/70-201000-005 base)	Photoelectric	0.10	**
Gentex 824	Photoelectric	0.50	**
Gentex 824T	Photoelectric	0.50	**
Gentex 824CP	Photoelectric	0.50	**
Gentex 824CPT	Photoelectric	0.50	**
System Sensor B112LP	Base	0.12	36
System Sensor B114LP	Base	**	**
System Sensor B404B	Base	**	**
System Sensor DH100ACDC	Photoelectric	0.15	0.70
System Sensor DH100ACDCLP	Photoelectric	0.15	0.70
System Sensor DH100ACDCLWP	Photoelectric	0.15	0.70
System Sensor DH400ACDCI	Ionization Duct	25	95
System Sensor DH400ACDCP	Photoelectric Duct	25	95
System Sensor 1112/24/D	Ionization	0.05	50
System Sensor 1424	Ionization	0.10	41
System Sensor 1451 (w/B402B base)	Ionization	0.10	39
System Sensor 2112/24ATR	Photoelectric	0.50	60/70
System Sensor 2112/24AITR	Photoelectric	0.50	60/70
System Sensor 2112/24/D	Photoelectric	0.05	50
System Sensor 2112/24R	Photoelectric	0.50	60/70
System Sensor 2112/24TR	Photoelectric	0.50	60/70
System Sensor 2112/24T/D	Photoelectric w/135° thermal	0.05	50
System Sensor 2112/24TSRB	Photoelectric w/135° thermal	15	45
System Sensor 2312/24TB	Photoelectric	0.12	50
System Sensor 2424	Photoelectric	0.10	41



System Sensor 2424TH	Photoelectric	0.10	41
System Sensor 2451	Photoelectric	0.10	39
System Sensor 2451TH (w/B402B base)	Photoelectric	0.10	39
System Sensor 2W-MOD	Loop test/maint. mod.	30	50
System Sensor 4W-B (12/24V)	Photoelectric	.05	23
System Sensor 4WT-B (12/24V)	Photoelectric I w/therm	.05	23
System Sensor 4WTA-B (12/24V)	I Photo w/therm/sounder	.05	35
System Sensor 4WTR-B (12/24V)	I Photo w/therm/relay	.05	35
System Sensor 4WTAR-B (12/24V)	I Photo w/therm/sounder/relay	.05	50
System Sensor 4WITAR-B (12/24V)	I Photo w/isolated therm/sounder/relay	.05	50
System Sensor 2WMOD2	I Loop test/maint. mod.	.05	**
System Sensor RRS-MOD	I Reversing relay/sync module	.05	**
System Sensor 6424	Projected beam	10	28.4
System Sensor Beam 1224(S)	Projected beam	17	38.5

\* Using Hochiki base HSC-4R

\*\*NOTE: Contact manufacturer for current draws

**APPENDIX A: PRODUCT DATASHEETS OF OPTIONAL EQUIPMENT**



**CA2Z**  
**CLASS A INITIATING**  
**DEVICE MODULE**

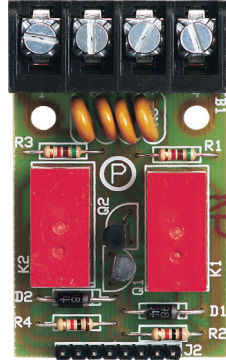

**UL Listed:** Option for use with the PFC-4410RC Series  
**Transient Protected**  
**Built In 5.1k End Of Line Resistor**  
**PC Board Assembly:** Mounts to PFC-4410RC Panel stand-offs  
**Stock No.** 3006013

The Model CA2Z Class A Module is designed to be used with the PFC-4410RC Fire Control Releasing Panel to convert from two (Class B) initiating device circuits to two (Class A) circuits.

The module is to be mounted in the upper right hand corner of the panel. Connection to the panel is made via the 8 pin header mounted on the back side of the CA2Z.

**Mounting**

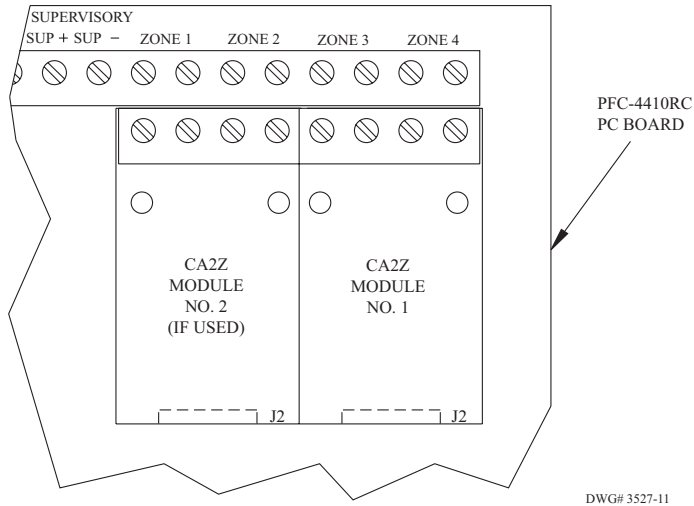

**Typical Wiring**

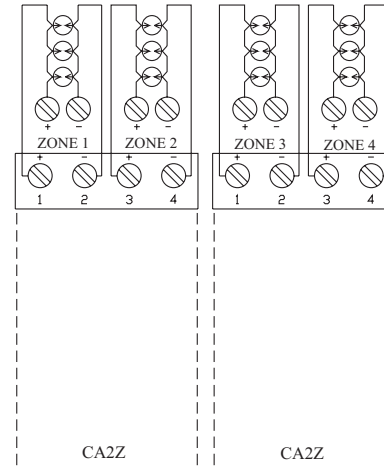



## CAM CLASS A INDICATING APPLIANCE CIRCUIT MODULE

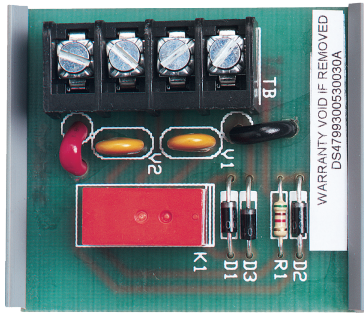

**UL Listed:** Option for use with the PFC-4410RC Series

**Transient protected**

**Power Requirements in Alarm:**

Approximately 25 mA at 24VDC from control panel indicating appliance circuit.

**Built in, polarized, 5.1k end of line resistor**

Stock number: 3005300

The Model CAM Class A Module is designed to be used with the PFC-4410RC Fire Control Releasing Panel to convert a single (Class B) indicating appliance circuit to a (Class A) circuit (one module is required for each indicating appliance circuit). After installing the

CAM, the indicating circuit should be activated to ensure proper operation and connections.

The module is provided with double sided foam tape and should be mounted in the area below the main circuit module so that the terminals are accessible.

### Mounting

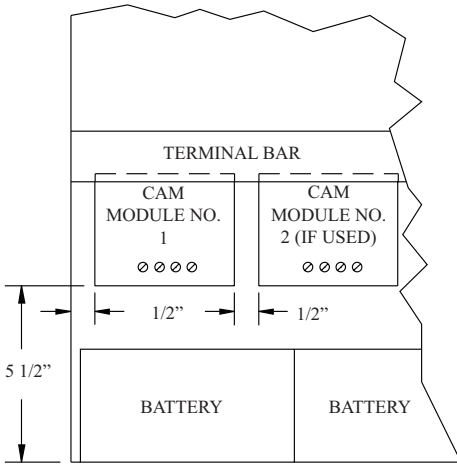

### Typical Wiring

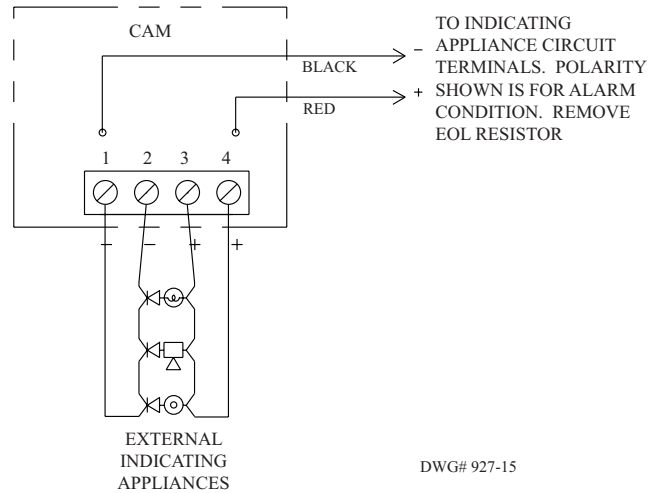



## ARM-2 AUXILIARY RELAY MODULE

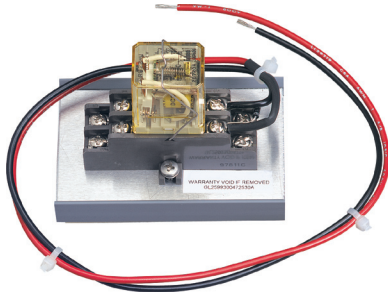

**UL Listed:** For use with the PFC-4410RC Series  
**Dimensions:** 2 1/4" x 3 1/2" x 3"  
**Weight:** .315 lb.  
**Assembly:** Socketed relay in plastic mounting track  
**Power Requirements:** 40mA at 24VDC  
**Contact Ratings:**  
 Each relay has DPDT contacts,  
 Rated at 7.5 amps resistive,  
 120VAC, 30VDC

**Stock number:** 3004725

The ARM-2 Auxiliary Relay Module is a UL listed option when factory installed in the Potter PFC-4410RC Series.  
 When the ARM-2 is used the additional power required for this relay module must be subtracted from the total circuit current available. See PFC-4410RC Manual #5403550. The ARM-2 Auxiliary Relay Module is a non-supervised DPDT Relay designed to be activated

by 24VDC Indicating and/or Releasing, polarity reversing circuits. The module can be used for fan shutdown, door release, elevator recall, etc.  
*Note: One to four ARM-2 modules in the PFC-4410RC series may be utilized to provide multiple auxiliary functions.*

### Wiring

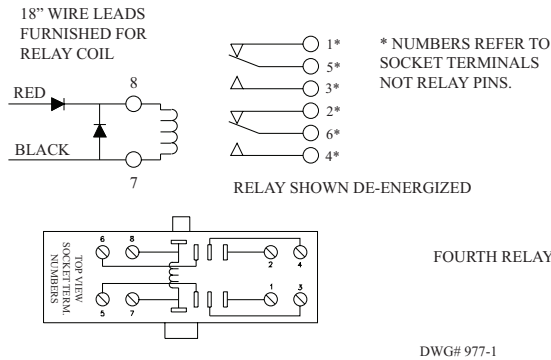

### Placement In PFC-4410RC Series Control Unit

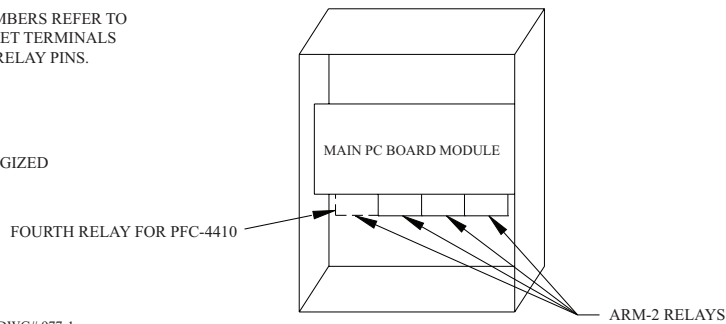

### ARM-2/PFC-4410RC Installation Hook-Up Diagram

All relays shown in non-activated condition

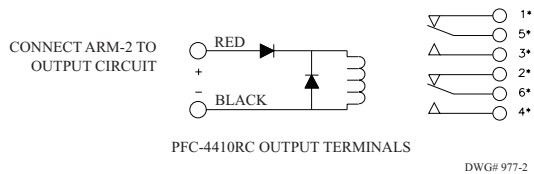

### Notes:

- \* Numbers refer to socket terminals not relay pins.
- Auxiliary relay operation is determined by programming of the PFC-4410RC Series panel. Consult the appropriate manual for further information.



## ARM-1 AUXILIARY RELAY MODULE

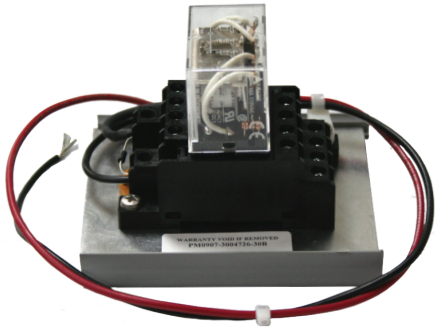

**UL Listed:** For use with the PFC-4410RC Series  
**Dimensions:** 3 1/4" X 3 1/4" X 4"  
**Weight:** .315 lb.  
**Assembly:** Socketed relay in plastic mounting track  
**Power Requirements:** 40mA at 24VDC  
**Contact Ratings:**  
 Each relay has 4PDT contacts,  
 Rated at 10 amps resistive,  
 24VDC

**Stock number:** 3004726

When the ARM-1 is used the additional power required for this relay module must be subtracted from the total circuit current available. The ARM-1 Auxiliary Relay Module is a non-supervised 4PDT Relay

designed to be activated by 24VDC Indicating and/or Releasing, polarity reversing circuits. The module can be used for fan shutdown, door release, elevator recall, etc.

### Wiring

18" WIRE LEADS  
 FURNISHED FOR  
 RELAY COIL

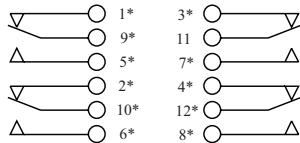
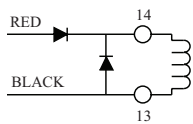

\* NUMBERS REFER TO  
 SOCKET TERMINALS  
 NOT RELAY PINS.

RELAY SHOWN DE-ENERGIZED

DWG# 1134-1

### Placement In PFC-4410RC Series Control Unit

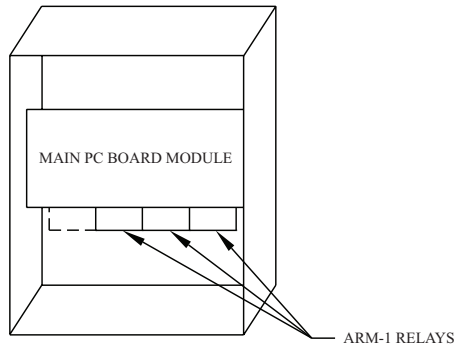

### ARM-1/PFC-4410RC Installation Hook-Up Diagram

All relays shown in non-activated condition

CONNECT ARM-1 TO  
 OUTPUT CIRCUIT

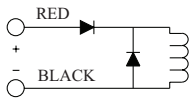

PFC-4410RC OUTPUT TERMINALS

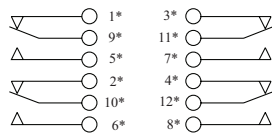

DWG# 1134-2

### Notes:

1. \* Numbers refer to socket terminals not relay pins.
2. Auxiliary relay operation is determined by programming of the PFC-4410RC panel. Consult the appropriate manual for further information.





