

	<h1 style="margin: 0;">TECHNICAL DATA</h1>	<h2 style="margin: 0;">FIRECYCLE® MULTI-CYCLE DETECTOR MODEL B</h2>
---	--	---

The Viking Corporation, 210 N Industrial Park Drive, Hastings MI 49058

Telephone: 269-945-9501 Technical Services: 877-384-5464 Fax: 269-818-1680 Email: techsvcs@vikingcorp.com

1. DESCRIPTION

The Viking Firecycle® Multi-Cycle Detector is a heat sensitive, normally closed, electrical detector, that operates at a fixed temperature. It is rate compensating and features automatic recycling. The detection units are connected with fire-resistant detector cable in series from and to the Firecycle® Multi-Cycle Control Panel. When a detector is heated to the temperature set point, a mechanical switch opens and breaks the series circuit interrupting the flow of current. When the temperature drops below the set point, the circuit is re-established.

A. Features

1. The detector trip temperature is factory set and is not adjustable in the field.
2. The detector includes a 300 °F (149 °C) indicating label. If the indicating label turns black, the detector must be replaced.
3. The conduit box is equipped with two (2) tabs, each with a 5/16" hole for mounting.
4. Maximum area coverage per detector is 1,600 square feet (149 sq. m) 40' x 40' (12.2 m x 12.2 m) spacing under optimum conditions. Refer to specific installation instructions Firecycle® III.

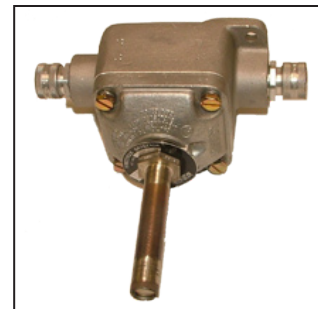

2. LISTINGS AND APPROVALS

UL Listed - VLTR
 FM Approved - On-Off Multi Cycle Systems
 California State Fire Marshal Listed - 7270-0533:103

Viking Technical Data may be found on The Viking Corporation's Web site at <http://www.vikinggroupinc.com>. The Web site may include a more recent edition of this Technical Data Page.

3. TECHNICAL DATA

Specifications

Weight: 32 oz. (.11 kg)
 Electrical Rating: 4 Amps at 125 V. AC or DC
 Resistance drop across closed detector: 0.03 Ohms
 Connections: ½" Threaded conduit (2) 5/16" mounting lugs

Material Standards

Heat Probe: Stainless Steel
 Name Plate: Aluminum
 Conduit Box: Copper free Aluminum

Ordering Information

Refer to Table 1.

Table 1 - Ordering Information		
Description	Temperature	Part Number
Use with Cable Part No. 16472 (data page 419a-b)		
Includes:	140 °F/60 °C	04711A
- Mounting box	160 °F/71 °C*	04717A
- Ceramic wire nuts	190 °F/88 °C*	04718A
- Aluminum compression cable fittings	225 °F/107 °C*	04719A
Use with Cable Part Nos. 09954 or 11988 (data page 419d-f)		
Includes:	140 °F/60 °C	08288
- Mounting box	160 °F/71 °C*	08289
- Ceramic wire nuts	190 °F/88 °C*	08290

4. INSTALLATION

NOTE: VIKING MODEL B FIRECYCLE DETECTORS SHOULD NOT BE INSTALLED IN OUTDOOR APPLICATIONS WHERE THEY ARE SUBJECT TO EXPOSURE TO MOISTURE. OUTDOOR APPLICATIONS WHERE MEASURES HAVE BEEN TAKEN TO PREVENT EXPOSURE TO MOISTURE ARE ACCEPTABLE. PRECAUTIONS MUST BE TAKEN WITHIN INDOOR APPLICATIONS WITH A HIGH HUMIDITY. HUMID ENVIRONMENTS CAN CAUSE MOISTURE TO BUILD UP WITHIN THE DETECTOR BACK BOX. IF MOISTURE IS ALLOWED TO ACCUMULATE WITHIN THE DETECTOR BACK BOX A GROUND FAULT CAN OCCUR ON THE CIRCUIT.

1. The detector must be mounted as shown in Figure 2 on page.
2. The temperature rating of the detector should be lower than the temperature rating of adjacent sprinklers.
3. Locate detectors between 12 inches (304.8 mm) and 18" (457.2 mm) of a sprinkler. (Refer to Paragraph E below for exceptions to this requirement.)
4. For installation of detectors, refer to NFPA 72. Do not exceed recommended spacing between detectors. Refer to Spacing Chart on page 417d. The minimum spacing from any wall or partition must not exceed one-half the maximum spacing allowed by NFPA 72.
5. A minimum of two detectors should be installed in every compartment for Firecycle® III Multi-Cycle installations. This reduces the possibility of short cycling caused from direct wetting of actuated detectors by operating sprinklers. Exceptions to this requirement include:
 - a. Light and Ordinary Hazard occupancy compartments (rooms) of 400 square feet (37.16 square meters) or less require only one detector. Also refer to c, d, and e on page 417 b.
 - b. Extra-Hazard occupancy compartments (rooms) of 256 square feet (23.78 square meters) or less require only one detector. Also refer to c, d, and e below.

**TECHNICAL DATA****FIRECYCLE® MULTI-CYCLE
DETECTOR
MODEL B**

The Viking Corporation, 210 N Industrial Park Drive, Hastings MI 49058

Telephone: 269-945-9501 Technical Services: 877-384-5464 Fax: 269-818-1680 Email: techsvcs@vikingcorp.com

- c. All areas protected by only one sprinkler require only one detector.
 - d. In compartments having only one sprinkler, locate the detector as remote as practical from the sprinkler, but not less than 4" (102 mm) from the sidewall.
 - e. In compartments described in a and b above, having two or more sprinklers, locate the detector approximately midway between the sprinklers.
6. The detector set point will be affected if the probe is dented or bent. Extreme care should be taken during installation to prevent any mechanical damage.
 7. The detector must be screwed into box cover. Do not use a wrench or pliers on shell. Use wrench only on 1" (25 mm) hex on base of detector. Connect detector leads to detector cable using porcelain wire connectors.
 8. The detector should be supported by suitable building structures such as beams, bar joist, joist roof deck, or member that is not easily affected by a fire of minor intensity.
 9. 1/4" bolts, rods, U-bolts, or standard Killark UL fixture hangers should be used for mounting.
 10. The detector probe should be kept out of contact with other material, such as ceiling tile, metal framing, etc., because such material may dissipate, heat and slow the operation of the detector.
 11. Detectors must be mounted in such a way that the sensing shell will not be damaged and that the ability of the detector to absorb heat is not impaired. Refer to Figure 2.
 12. Detector Cable must be installed in accordance with the system listings and approvals. Refer to appropriate Technical Data Page(s) for additional information regarding detectors.

5. OPERATION

The Viking Firecycle® Multi-Cycle Detector is a mechanical switch that is closed at normal room temperature. When the ambient temperature increases to the set point, the contacts open. When the ambient temperature drops below the set point, the contacts close.

6. INSPECTIONS, TESTS AND MAINTENANCE

The detector should be kept clean and tested for operation annually. Detectors may be tested by the use of a heat gun directed at the shell of the detector or by immersing the probe in a container of heated water. Care should be taken to not allow water to enter the back box as this could cause a fault. When the detector operates, an Ohm-meter connected across the detector leads will indicate an open circuit.

The detector set point will be affected if the probe is dented or bent. If a detector is subject to a temperature of 300 °F (149 °C), the indicating label will turn black, and the detector must be replaced.

7. AVAILABILITY

The Viking Firecycle® Multi-Cycle Detector is available through a network of domestic and international distributors. See the Viking Corp. Web site for closest distributor or contact The Viking Corporation.

8. GUARANTEE

For details of warranty, refer to Viking's current list price schedule or contact Viking directly.



TECHNICAL DATA

FIRECYCLE® MULTI-CYCLE DETECTOR MODEL B

The Viking Corporation, 210 N Industrial Park Drive, Hastings MI 49058

Telephone: 269-945-9501 Technical Services: 877-384-5464 Fax: 269-818-1680 Email: techsvcs@vikingcorp.com

Figure 1 - Firecycle® Wiring Diagram

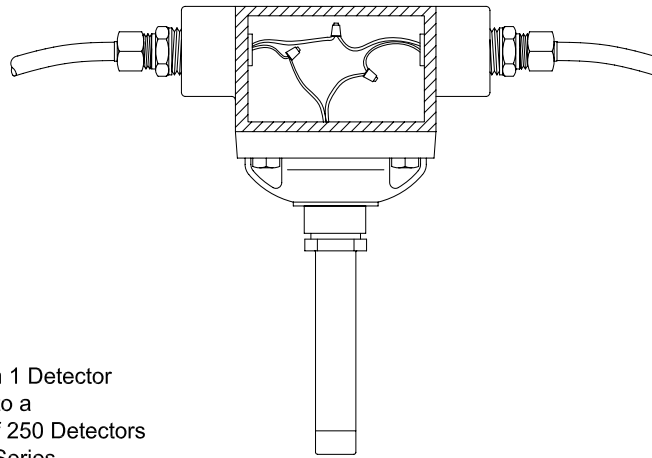

Minimum 1 Detector
to a
Maximum of 250 Detectors
in Series

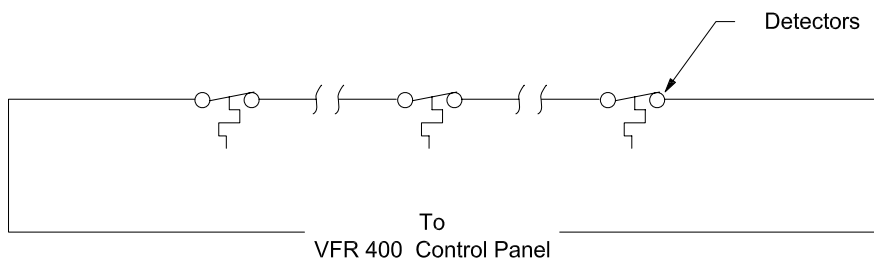
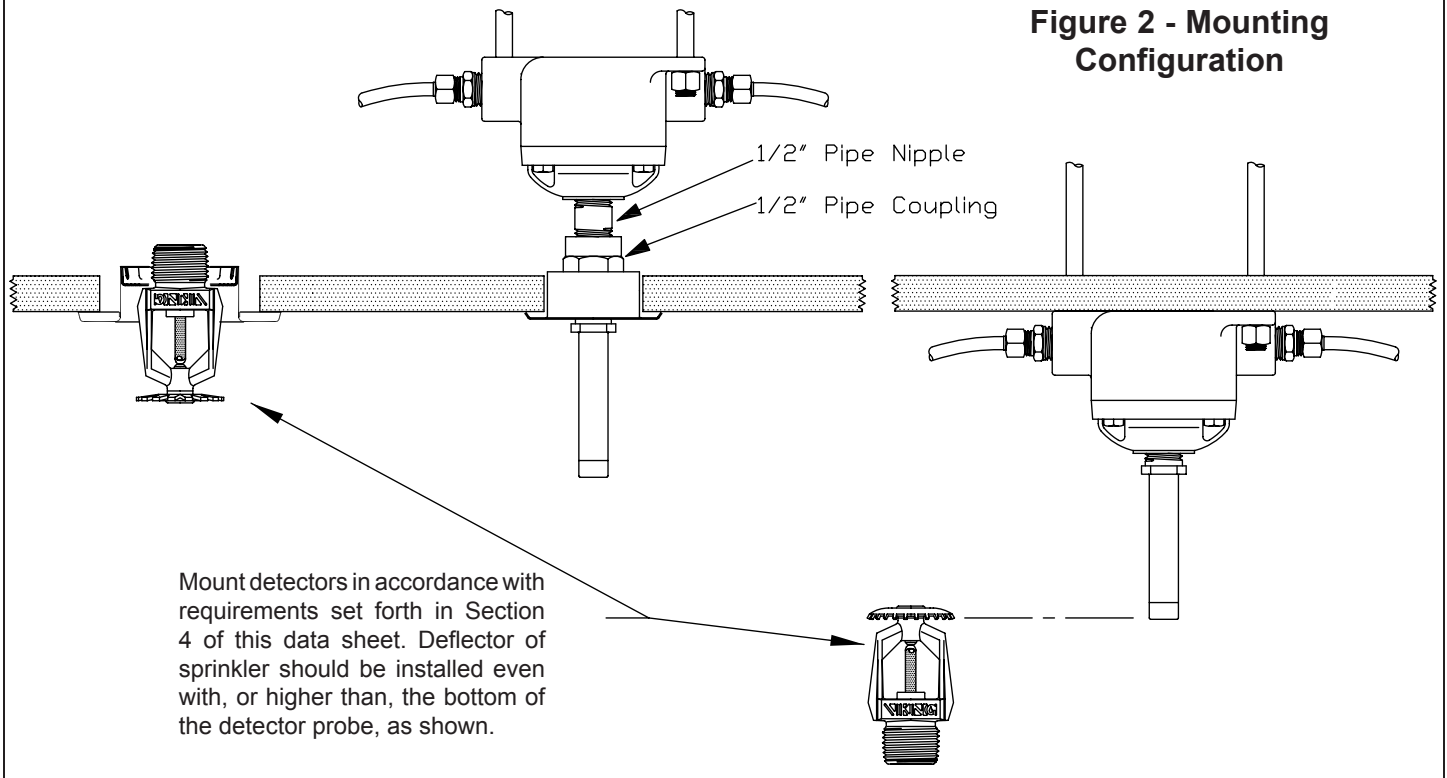

Figure 2 - Mounting Configuration





TECHNICAL DATA

**FIRECYCLE® MULTI-CYCLE
DETECTOR
MODEL B**

The Viking Corporation, 210 N Industrial Park Drive, Hastings MI 49058

Telephone: 269-945-9501 Technical Services: 877-384-5464 Fax: 269-818-1680 Email: techsvcs@vikingcorp.com

**Table 2 - Recommended Maximum Detector Spacing
for Firecycle® II or Firecycle® III Installations
When Detector is used with Standard Response Sprinklers***

Detector Temperature Rating	Sprinkler Temperature Rating			
	155 °F (68 °C)	175 °F (79 °C)	200 °F (93 °C)	286 °F (141 °C)
140 °F (60 °C)	40' x 40'	40' x 40'	40' x 40'	40' x 40'
	(12 m x 12 m)	(12 m x 12 m)	(12 m x 12 m)	(12 m x 12 m)
160 °F (71 °C)	NOT USED	25' x 25'	25' x 25'	25' x 25'
		(7.6 m x 7.6 m)	(7.6 m x 7.6 m)	(7.6 m x 7.6 m)
190 °F (88 °C)	NOT USED	NOT USED	25' x 25'	25' x 25'
			(7.6 m x 7.6 m)	(7.6 m x 7.6 m)
225 °F (107 °C)	NOT USED	NOT USED	NOT USED	25' x 25'
				(7.6 m x 7.6 m)

*For detector spacing for Firecycle® installations with other sprinklers, refer to NFPA 72.

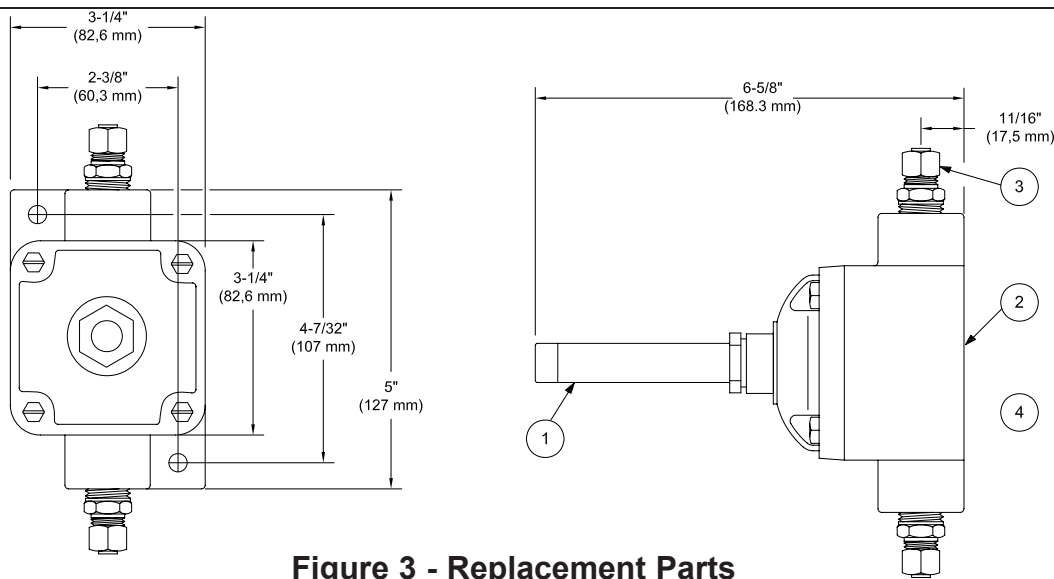

Figure 3 - Replacement Parts

ITEM NO.	PART NUMBER	DESCRIPTION	MATERIAL	NO. REQ'D
1	04625B	140°F (60°C) Probe	Stainless Steel	1
	04626B	160°F (71°C) Probe	Stainless Steel	
	04627B	190°F (88°C) Probe	Stainless Steel	
	04628B	225°F (107°C) Probe	Stainless Steel	
2	04629A	Box and Cover	Aluminum	1
3	04016A	Cable Fitting**	Aluminum Buna H	2
4	04631A	Wire Connector	Porcelain	2

**Not included or required with detector for use with wire in conduit.