

	<h1 style="margin: 0;">TECHNICAL DATA</h1>	<p><b>FLOW CONTROL VALVE</b>  <b>MODEL J-1</b>  <b>1-1/2" &amp; 2" (DN40 &amp; DN50)</b></p>
---	--	--

**The Viking Corporation, 210 N Industrial Park Drive, Hastings MI 49058**

**Telephone: 269-945-9501 Technical Services: 877-384-5464 Fax: 269-818-1680 Email: techsvcs@vikingcorp.com**

**1. DESCRIPTION**

The Viking Flow Control Valve is a quick opening, differential diaphragm flood valve with a spring loaded floating clapper. The Flow Control Valve can be used to facilitate manual or automatic on/off control. It can also be used to control water pressure or flow rates. As an on/off control valve it is used on Deluge Systems, Sprinkler Systems or to automatically fill tanks or reservoirs.

**Features**

- Field replaceable Diaphragm and Seat Rubbers
- Designed for installation in the horizontal or vertical position
- Compatible with Hydraulic (See Figure 2), Pneumatic, and/or Electric Detection Systems
- Designed to be reset without opening the valve
- Can be trimmed to automatically reset electrically or manually



**2. LISTINGS AND APPROVALS:**

U.L. Listed - Guide No. VLFT & VLLA  
 C-UL Listed  
 FM Approved - On-Off Multi Cycle Sprinkler Systems  
 ABS Certificate number: 04-CH557068-X  
 NYC Department of Buildings - MEA 89-92-E Vol. XXXI

**3. TECHNICAL DATA**

**Specifications:**

Style: Straight through pattern  
 Connections available: Refer to Table 1  
 Pressure Rating: Maximum 250 PSI (17.2 bar) Working Water Pressure  
 Hydrostatically tested: to 500 PSI (34.5 bar) at factory  
 Priming Chamber supply restriction (required): 0.125" (3.1 mm)  
 Color: Red  
 Friction Loss: Refer to Table 1.  
 C<sub>v</sub> Factor: Refer to Table 1.

**Material Standards:**

Refer to Figure 3.

**Ordering Information:**

Refer to Table 1 for part numbers and shipping weights.

Viking Technical Data may be found on The Viking Corporation's Web site at <http://www.vikinggroupinc.com>. The Web site may include a more recent edition of this Technical Data Page.

$$Q = C_v \sqrt{\frac{\Delta P}{S}}$$

Q = Flow  
 C<sub>v</sub> = Flow Factor (GPM/1 PSI ΔP)  
 ΔP = Pressure Loss through Valve  
 S = Specific Gravity of Fluid

**Table 1: Valve Part Numbers and Specifications**

DESCRIPTION	NOMINAL SIZE	PART NUMBER	FRICTION LOSS*	CV FACTOR	SHIPPING WEIGHT
<b>Threaded</b>					
<u>Pipe O.D.</u>					
NPT 48 mm	1½"	12130	7	66	37 lbs. (16.8 kg)
NPT 60 mm	2"	12063	13	93	37.5 lbs. (17 kg)
BSP 48 mm	DN40	12684	7	66	37 lbs. (16.8 kg)
BSP 48 mm	DN50	12688	13	93	37.5 lbs. (17 kg)
<b>Groove/Groove</b>					
<u>Pipe O.D.</u>					
48 mm	1½" / DN40	12129	7	66	36 lbs. (16.3 kg)
60 mm	2" / DN50	12061	13	93	36.5 lbs. (16.6 kg)

\* Expressed in equivalent length of Schedule 40 pipe based on Hazen & Williams formula C = 120



# TECHNICAL DATA

## FLOW CONTROL VALVE MODEL J-1 1-1/2" & 2" (DN40 & DN50)

The Viking Corporation, 210 N Industrial Park Drive, Hastings MI 49058

Telephone: 269-945-9501 Technical Services: 877-384-5464 Fax: 269-818-1680 Email: techsvcs@vikingcorp.com

### Accessories:

- A Conventional Trim package for use with the Model J Flow Control Valve. The trim package includes all required trim components and all fittings and nipples shown on the Viking Model J Flow Control Valve Conventional Trim Chart for the valve used. Trim Charts are provided in trim packages and the *Viking Engineering and Design Data* book.
- For optional pre-assembled trim packages, refer to the Viking list price schedule or contact the manufacturer.
- Auxiliary Components are required for specific valve functions. For complete operating trim requirements refer to System Data for the system used. System Data is provided in the *Viking Engineering and Design Data* book.

**NOTE: FOR PART NUMBERS OF ACCESSORIES, REFER TO VIKING LIST PRICE SCHEDULE.**

## 4. INSTALLATION (Refer to Figure 1 for identification of trim components.)

### A. General Instruction

1. Viking 1-1/2" (DN40) and 2" (DN50) Flow Control Valves may be installed in the horizontal or vertical position.

**NOTE: FOR POSITIONS OTHER THAN VERTICAL, MINOR MODIFICATION OF TRIM MAY BE REQUIRED TO FACILITATE DRAINAGE FROM OUTLET CHAMBER OF THE FLOW CONTROL VALVE (CONSULT MANUFACTURER).**

2. The valve must be installed in an area not subject to freezing temperatures or physical damage.
3. The valve must be trimmed according to current Viking Model J Conventional Trim Charts and appropriate instructions for the system used. Trim Charts are printed in the *Viking Engineering and Design Data* book, and are provided with trim packages. For additional trim connections, refer to technical data describing the system being installed.
4. The priming line must be connected upstream of the system water supply main control valve or to a constant source of water at a pressure equal to the system water supply.
5. After the Flow Control Valve is set, operation of the Flow Control Valve requires the release of priming water from the priming chamber. This may be by automatic or manual operation of the release system. Viking Flow Control Valves are compatible with hydraulic, pneumatic, and electric release systems. For specific Trim arrangements, refer to Trim Charts, Technical Data, and System Data describing the system being installed. Trim Charts are printed in the *Viking Engineering and Design Data* book and are provided with trim packages. Technical Data and System Data sheets are printed in the *Viking Engineering and Design Data* book.
  - a. Hydraulic Release Systems: See Figure 2 for the maximum allowable elevation of hydraulic release piping above the Flow Control Valve. If the maximum height of hydraulic release piping exceeds the limit shown in Figure 2 for the valve used, use a Pneumatic or Electric Release System.
  - b. Pneumatic Release Systems: A Viking Pneumatic Actuator is required between the release system connection provided on flow Control Trim and pneumatic release system piping.

**CAUTION: WHEN RELEASING DEVICES CAPABLE OF AUTOMATICALLY RESETTING ARE USED ON THE PNEUMATIC RELEASE SYSTEM OF A FLOW CONTROL VALVE, VIKING MODEL F DELUGE VALVE CONVENTIONAL TRIM, COMPLETE WITH PORV, IS REQUIRED. THIS ARRANGEMENT WILL NOT ALLOW THE FLOW CONTROL VALVE TO AUTOMATICALLY RESET.**

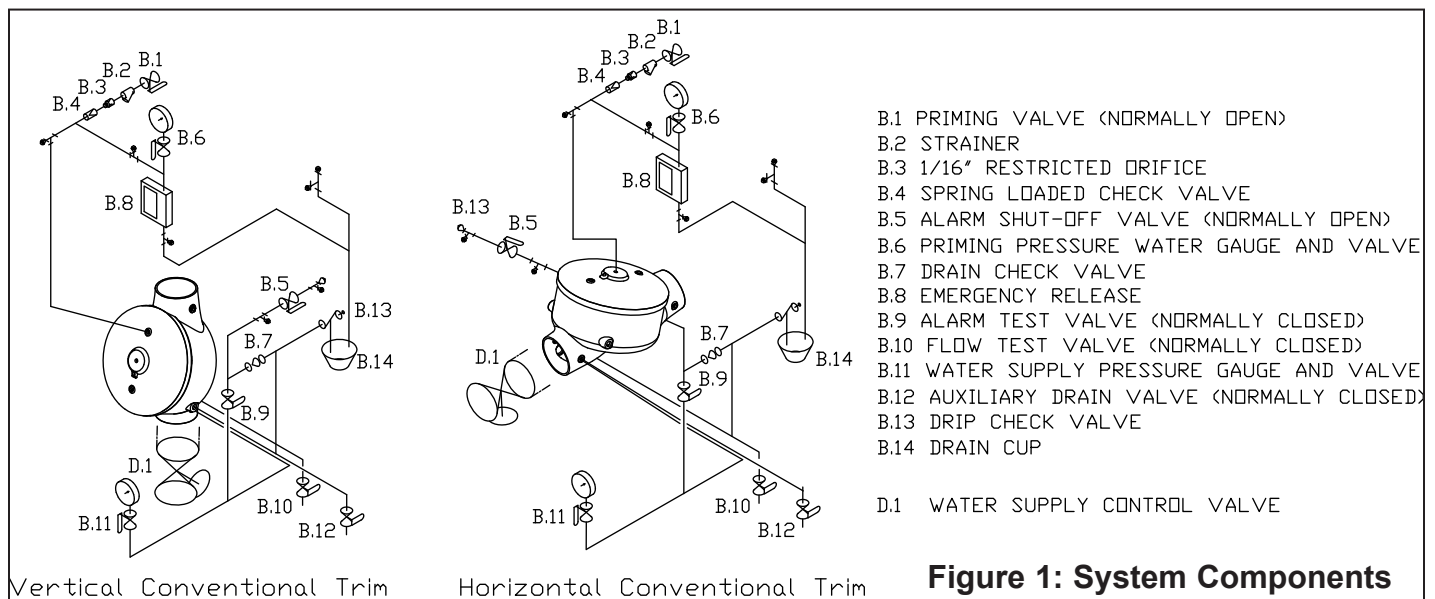

**Figure 1: System Components**

	<h1 style="margin: 0;">TECHNICAL DATA</h1>	<p><b>FLOW CONTROL VALVE</b>  <b>MODEL J-1</b>  <b>1-1/2" &amp; 2" (DN40 &amp; DN50)</b></p>
---	--	--

**The Viking Corporation, 210 N Industrial Park Drive, Hastings MI 49058**

**Telephone: 269-945-9501 Technical Services: 877-384-5464 Fax: 269-818-1680 Email: techsvcs@vikingcorp.com**

c. Electric Release Systems: Solenoid Valves, Release Control Panels, and Electrical Detectors must be compatible. Consult appropriate listing and/or approval guides.

6. The Viking Flow Control Valve can be trimmed to automatically reset electrically or manually. For specific Trim arrangements refer to System Data describing the system being installed.

**NOTE: DO NOT INSTALL ANY RELEASING DEVICE, OR VALVE USED TO AUTOMATICALLY RESET THE FLOW CONTROL VALVE, ON PNEUMATIC RELEASE PIPING.**

For pneumatic release systems, any releasing valve or device used to automatically reset the Flow Control Valve must be installed in the trim piping between the Pneumatic Actuator and the priming chamber outlet.

**CAUTION: OPERATION OF VIKING FLOW CONTROL VALVES BY PRESSURIZING THE PRIMING CHAMBER WITH AIR OR ANY OTHER PRESSURIZED GAS IS NOT RECOMMENDED OR APPROVED.**

**B. Placing the Valve in Service** Refer to Figure 1 and/or appropriate Trim Charts and System Data for the system used.

1. Verify:

- a. The system Main Water Supply Control Valve (D.1) is closed and the Flow Control Valve is trimmed according to current Viking Trim Charts and schematic drawings for the system used.
- b. The system has been properly drained.
- c. Auxiliary Drain (B.12) is open.
- d. The Emergency Release (B.8) is closed.
- e. The system water supply piping is pressurized up to the closed Main Water Supply Control Valve (D.1) and the priming line is pressurized up to the closed Priming Valve (B.1).

**Maximum Allowable Pilot Heights for Select Equivalent Lengths of Hydraulic Release Piping  
 Model J-1 Flow Control Valves with 1/8" (3.2 mm) Restricted Orifice**

Graph is based on 1/2" (15 mm) pilot sprinklers installed on 1/2" (15 mm) schedule 40 galvanized release system piping.

If the maximum height of hydraulic release piping exceeds the limits shown on the graph, use Pneumatic or Electric Release System.

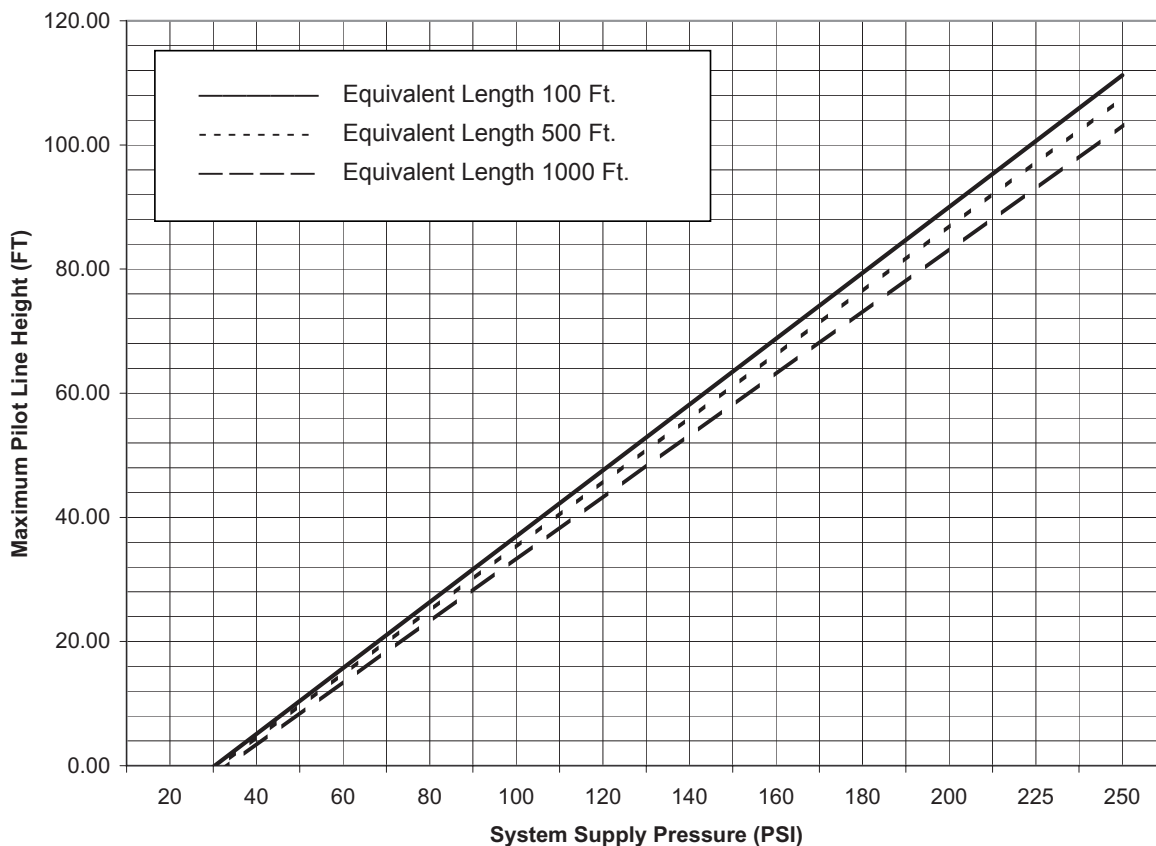

**Figure 2: 1-1/2" & 2" Valves**



The Viking Corporation, 210 N Industrial Park Drive, Hastings MI 49058

Telephone: 269-945-9501 Technical Services: 877-384-5464 Fax: 269-818-1680 Email: techsvcs@vikingcorp.com

2. For Systems equipped with:
  - a. Hydraulic Release Systems:
    - i. Verify that all releasing devices are set and that any Inspector's Test Valve and/or auxiliary drain valves are closed.
    - ii. Open Priming Valve (B.1). Proceed to step 3.
  - b. Pneumatic Release Systems:
    - i. Set the release system.
    - ii. Open Priming Valve (B.1). Proceed to step 3.
  - c. Electric Release Systems:
    - i. Open Priming Valve (B.1).
    - ii. Set the electric release system. Proceed to step 3.
3. Open Flow Test Valve (B.10).
4. Partially open Main Water Supply Control Valve (D.1).
5. When full flow develops from the Flow Test Valve (B.10), close the Flow Test Valve. Verify that there is no flow from the open Auxiliary Drain (B.12).
6. Close Auxiliary Drain (B.12).
7. Fully open and secure the Main Water Supply Control Valve (D.1).
8. Verify that the Alarm Shut-off Valve (B.5) is open and that all other valves are in their normal\* operating position.
9. Depress the plunger of Drip Check (B.13). No water should flow from the Drip Check when the plunger is pushed.
10. Check for and repair all leaks.
11. On new installations, those systems that have been placed out of service or where new equipment has been installed, trip test the system to verify that all equipment functions properly. Refer to MAINTENANCE paragraph 6-B. ANNUAL maintenance instructions.

**CAUTION: PERFORMING A TRIP TEST RESULTS IN OPERATION OF THE FLOW CONTROL VALVE. WATER WILL FLOW INTO THE SPRINKLER PIPING. TAKE NECESSARY PRECAUTIONS TO PREVENT DAMAGE.**

12. After completing a trip test, perform SEMI-ANNUAL maintenance.

#### **C. Automatic Resetting**

Refer to Figure 1 for identification of trim components.

To automatically reset the Flow Control Valve after it has operated:

1. DO NOT close the water supply main control valve (D.1). The priming valve (B.1) must be OPEN.
2. Automatically or manually reset any open devices on the hydraulic release system to stop all flow of water out of the priming chamber.

**CAUTION: RESETTING OR CLOSING RELEASING DEVICES OR VALVES ON PNEUMATIC RELEASE PIPING WILL NOT AUTOMATICALLY CAUSE THE FLOW CONTROL VALVE TO RESET.**

DO NOT install any releasing device or valve, used to automatically reset the Flow Control Valve, on pneumatic release piping.

3. System supply pressure will enter the priming chamber through the restricted priming line connected to the priming chamber inlet.
4. When the combined force of spring pressure and system supply pressure entering the priming chamber overcomes the velocity pressure of water flowing through the valve, the clapper will close.
5. Flow through the valve will stop.
6. To reactivate the system, open a releasing device. Priming water will escape from the priming chamber faster than it is replaced through the restricted priming line, allowing the Flow Control Valve to open.

#### **D. Valve Removed From Service**

**NOTE: WHEN A VALVE HAS BEEN REMOVED FROM SERVICE AND IS SUBJECT TO FREEZING OR WILL BE OUT OF SERVICE FOR AN EXTENDED PERIOD OF TIME, ALL WATER MUST BE REMOVED FROM THE PRIMING CHAMBER, TRIM PIPING, WATER SUPPLY PIPING AND OTHER TRAPPED AREAS.**

### **5. OPERATION** (Refer to Figure 3.)

The Model J-1 Flow Control valve has an inlet chamber, an outlet chamber, and a priming chamber. The inlet chamber and outlet chamber are separated from the priming chamber by the clapper (5) and diaphragm (6).

System pressure enters the priming chamber through a restricted priming line (trim) equipped with a check valve.

#### **In the SET position:**

System pressure is trapped in the priming chamber to hold clapper (5) on seat (2) due to area differential of the clapper, and spring (13) pressure. Clapper (5) separates the inlet from the outlet, keeping the system piping dry.

	<h1>TECHNICAL DATA</h1>	<p><b>FLOW CONTROL VALVE MODEL J-1 1-1/2" &amp; 2" (DN40 &amp; DN50)</b></p>
---	-------------------------	--

The Viking Corporation, 210 N Industrial Park Drive, Hastings MI 49058

Telephone: 269-945-9501 Technical Services: 877-384-5464 Fax: 269-818-1680 Email: techsvcs@vikingcorp.com

### In fire conditions:

When the release system operates, pressure is released from the priming chamber faster than it is supplied through the restricted priming line. Water supply pressure in the inlet chamber forces the clapper (5) off from seat (2) allowing water to flow through the outlet and into the system piping and alarm devices.

To automatically reset, flow of water out of the priming chamber is stopped. This can be done manually (by closing a valve in the hydraulic release piping), or electrically (by closing a solenoid valve in the hydraulic release piping). When the combined force of spring (13) pressure and system supply pressure entering the priming chamber overcomes the velocity pressure of water flowing through the valve, the clapper (5) will close. Flow through the valve will stop.

## 6. INSPECTIONS, TESTS AND MAINTENANCE (Refer to Figure 1 for identification of trim components.)

### Inspection

It is imperative that the system is inspected and tested on a regular basis. The frequency of the inspections may vary due to contaminated water supplies, corrosive water supplies or corrosive atmospheres. Also, the alarm devices, detection systems or other connected trim may require a more frequent schedule. For minimum maintenance and inspection requirements, refer to NFPA 25. In addition, the Authority Having Jurisdiction may have additional maintenance, testing, and inspection requirements that must be followed. The following recommendations are minimum requirements. (For additional information, refer to Viking Trim Charts and System Data describing systems with the release system used.)

### Weekly:

Weekly visual inspection of the Viking Flow Control Valve is recommended.

1. Verify that the Main Water Supply Control Valve (D.1) is open and that all other valves are in their normal\* operating position and appropriately secured.
2. Check for signs of mechanical damage, leakage, and/or corrosive activity. If detected, perform maintenance as required. If necessary, replace the device.
3. Verify that the valve and trim are adequately heated and protected from freezing and physical damage.

### Tests

#### A. Quarterly:

Quarterly testing of water flow alarms and performance of a Main Drain Test is recommended and may be required by the Authority Having Jurisdiction.

#### I. Water Flow Alarm Test

1. Notify the Authority Having Jurisdiction and those in the area affected by the test.
2. To test the local electric alarm (if provided) and/or mechanical water motor alarm (if provided), OPEN the alarm test valve (B.9) in the Flow Control Valve trim.
  - a. Electric alarm pressure switches (if provided) should activate.
  - b. Electric local alarms should be audible.
  - c. The local water motor gong should be audible.
  - d. If equipped with remote station alarm signaling devices, verify that alarm signals were received.
3. When testing is complete, CLOSE the alarm test valve (B.9).
4. Verify:
  - a. All local alarms stop sounding and alarm panels (if provided) reset.
  - b. All remote station alarms reset.
  - c. Supply piping to water motor alarm properly drains.
5. Verify that the alarm shut-off valve (B.5) is OPEN, and the alarm test valve (B.9) is CLOSED.
6. Verify that the outlet chamber is free of water. No water should flow from the drip check (B.13) when the plunger is pushed.
7. Notify the Authority Having Jurisdiction and those in the affected area that testing is complete.

#### II. Main Drain Test

1. Notify the Authority Having Jurisdiction and those in the area affected by the test.
2. Record pressure reading from the water supply pressure gauge (B.11).
3. Verify that the outlet chamber of the Flow Control Valve is free of water. No water should flow from the drip check (B.13) when the plunger is pushed.
4. Fully OPEN the Flow Test Valve (B.10).
5. When a full flow is developed from the Flow Test Valve (B.10), record the residual pressure from the water supply pressure gauge (B.11).
6. When the test is complete, SLOWLY CLOSE the Flow Test Valve (B.10).
7. Compare test results with previous flow information. If deterioration of the water supply is detected, take appropriate steps to restore adequate water supply.

	<h1>TECHNICAL DATA</h1>	<p><b>FLOW CONTROL VALVE MODEL J-1 1-1/2" &amp; 2" (DN40 &amp; DN50)</b></p>
---	-------------------------	--

The Viking Corporation, 210 N Industrial Park Drive, Hastings MI 49058

Telephone: 269-945-9501 Technical Services: 877-384-5464 Fax: 269-818-1680 Email: techsvcs@vikingcorp.com

8. Verify:
  - a. Normal water supply pressure has been restored to the inlet chamber, the priming chamber, and the release system. The pressure on the priming chamber water pressure gauge should equal the system water supply pressure.
  - b. All alarm devices, and valves are secured in normal operating position.
9. Notify the Authority Having Jurisdiction that the test is complete. Record and/or provide notification of test results as required by the Authority Having Jurisdiction.

## B. Annual

Annual Trip Tests are recommended.

**CAUTION! PERFORMING THIS TEST RESULTS IN OPERATION OF THE FLOW CONTROL VALVE. WATER WILL FLOW INTO THE SPRINKLER PIPING AND FROM ANY OPEN SPRINKLERS AND/OR NOZZLES. TAKE NECESSARY PRECAUTIONS TO PREVENT DAMAGE.**

1. Notify the Authority Having Jurisdiction and those in the area affected by the test.
2. Fully open the Flow Test Valve (B.10) to flush away any accumulation of foreign material.
3. Close the Flow Test Valve (B.10).
4. Trip the system by operating the release system. Allow a full flow to pass through the Flow Control Valve. Water flow alarms should operate.

When test is complete:

5. For Flow Control Valves equipped with:
  - a. Hydraulic or Electric Release:
    - i. Re-set the Release System. Pressure in the priming chamber should gradually be restored. Flow through the Flow Control Valve should stop.
    - ii. Proceed to step 6.
  - b. Pneumatic Release Systems:
    - i. Close the Main Water Supply Control Valve (D.1) and Priming Valve (B.1).
    - ii. Open Auxiliary Drain Valve (B.12).
    - iii. Open all system main drains and auxiliary drains. Allow the system to drain completely. Proceed to step 6.
6. Perform SEMI-ANNUAL maintenance. Refer to paragraph 6.C.2, SEMI-ANNUAL MAINTENANCE
7. Place the system in service. Refer to Item 4.B, INSTALLATION: PLACING THE VALVE IN SERVICE.

**NOTE: VALVES SUPPLIED BY BRACKISH WATER, SALT WATER, FOAM, FOAM/WATER SOLUTION, OR ANY OTHER CORROSIVE WATER SUPPLY, SHOULD BE FLUSHED WITH GOOD QUALITY FRESH WATER BEFORE BEING RETURNED TO SERVICE.**

8. Notify the Authority Having Jurisdiction that the test is complete. Record and/or provide notification of test results as required by the Authority Having Jurisdiction.

## C. Maintenance (Refer to Figure 1 for identification of trim components.)

**NOTICE: THE OWNER IS RESPONSIBLE FOR MAINTAINING THE FIRE PROTECTION SYSTEM AND DEVICES IN PROPER OPERATING CONDITION. THE FLOW CONTROL VALVE MUST BE KEPT FROM FREEZING CONDITIONS AND PHYSICAL DAMAGE THAT COULD IMPAIR ITS OPERATION.**

Where difficulty in performance is experienced, the valve manufacturer or authorized representative shall be contacted if any field adjustment is to be made.

**WARNING: ANY SYSTEM MAINTENANCE THAT INVOLVES PLACING A CONTROL VALVE OR DETECTION SYSTEM OUT OF SERVICE MAY ELIMINATE THE FIRE PROTECTION CAPABILITIES OF THAT SYSTEM. PRIOR TO PROCEEDING, NOTIFY ALL AUTHORITIES HAVING JURISDICTION. CONSIDERATION SHOULD BE GIVEN TO EMPLOYMENT OF A FIRE PATROL IN THE AFFECTED AREAS.**

### 1. After Each Operation:

- a. Sprinkler systems that have been subjected to a fire must be returned to service as soon as possible. The entire system must be inspected for damage, and repaired or replaced as necessary.
- b. Flow Control Valves and trim that have been subjected to brackish water, salt water, foam, foam/water solution, or any other corrosive water supply, should be flushed with good quality fresh water before being returned to service.
- c. Perform SEMI-ANNUAL maintenance after every operation.

### 2. Semi-Annual Maintenance:

- a. Remove the system from service. (See release system description and technical data for additional information.)
  - i. Close the Main Water Supply Control Valve (D.1) and Priming Valve (B.1).
  - ii. Open the Auxiliary Drain Valve (B.12). Allow the outlet chamber of the Flow Control Valve to drain completely.
  - iii. Release the pressure in the priming chamber by opening the Emergency Release Valve (B.8).

	<h1 style="margin: 0;">TECHNICAL DATA</h1>	<p><b>FLOW CONTROL VALVE</b>  <b>MODEL J-1</b>  <b>1-1/2" &amp; 2" (DN40 &amp; DN50)</b></p>
---	--	--

The Viking Corporation, 210 N Industrial Park Drive, Hastings MI 49058

Telephone: 269-945-9501 Technical Services: 877-384-5464 Fax: 269-818-1680 Email: techsvcs@vikingcorp.com

- b. Inspect all trim for signs of corrosion and/or blockage. Clean and/or replace as required.
- c. Clean and/or replace all strainer screens.
- d. Refer to Item 4.B, INSTALLATION: PLACING THE VALVE IN SERVICE.

## 2. Every Fifth Year

- a. Internal inspection of Flow Control Valves is recommended every five years unless inspections and tests indicate more frequent internal inspections are required. Refer to DISASSEMBLY instructions provided below.
- b. Internal inspection of strainers and restricted orifices is recommended every five years unless inspections and tests indicate more frequent internal inspections are required.
- c. Record and provide notification of inspection results as required by the Authority Having Jurisdiction.

## 3. Valve Disassembly

- a. Remove the valve from service
  - i. Close the main water supply control valve (D.1) and priming valve (B.1).
  - ii. Open the auxiliary drain valve (B.12).
  - iii. Release the pressure in the priming chamber by opening the emergency release valve (B.8).
- b. Disconnect and remove trim from the cover (4).
- c. **Remove the cover (4):** Remove each of the cap screws (9). (Note: It is recommended to remove a top and bottom screw after removing the other screws first.) For 1-1/2" and 2" valves, use a socket wrench with a 9/16" socket.
- d. Lift the cover (4) from the body (1) and the spring (13) from the clapper (5).

## 4. Installing Replacement Parts and Valve Reassembly (Refer to Figure 2.)

- a. To replace the spring (13) only:
  - i. It can be difficult to hold the Spring (13) in place while replacing the Cover (4). A method to make this easier is to take the Cover (4) and place a screwdriver through the Cover (4) and place the Spring (13) onto the screwdriver, and re-install the Cover (4).
- b. To replace the entire clapper assembly (3, 5, 6, 7, & 10), which is ordered preassembled:
  - i. Remove the existing clapper assembly (3, 5, 6, 7, & 10) by placing a flat head screwdriver between the body of the valve (1) and the upper diaphragm (6) and then lifting the clapper assembly from the valve body (1).
  - ii. Inspect the seat (2). If replacement is necessary, see step h below.

**NOTE: Prior to reassembly, flush the valve of all foreign matter. The valve seat (2) must be clean and free from all marks and scratches.**

- iii. Install the new clapper assembly kit (3, 5, 6, 7, & 10) into the valve body (1).

If the entire clapper assembly does not need to be replaced, each of the parts of the clapper assembly kit are offered individually for replacement.

- c. First, remove the circle of screws (10). For 1-1/2" and 2" valves, use a Phillips head screwdriver.
  - d. To replace the clamp ring (3):
    - i. Place the Clamp Ring (3) on the Clapper (5), line up the holes and replace the screws (10) using a Phillips head screwdriver.
  - e. To replace the upper diaphragm (6):
    - i. Remove the existing clamp ring (3) (step d above).
    - ii. Remove the existing upper diaphragm (6). Note: The raised edge of the upper diaphragm (6) faces down toward the grooved seat of the clapper (5).
    - iii. Install the new upper diaphragm (6) and reinstall the clamp ring (3).
    - iv. Line up the holes and replace the screws (10) using a Phillips head screwdriver.
  - f. To replace the rubber seat assembly (7):
    - i. The clapper assembly (3, 5, 6, 7, & 10) must be removed from the valve (step b above).
    - ii. Turn the clapper (5) over and remove the circle of screws (10). For 1-1/2" and 2" valves, use a Phillips head screwdriver.
    - iii. The raised edge on the center of the rubber seat faces down into the grooved seat of the clapper (5).
    - iv. Line up the holes and replace the screws (10) using a Phillips head screwdriver.
  - g. To replace the clapper (5):
    - i. Remove the clamp ring (3), the upper diaphragm (6), and the rubber seat assembly (7) from the existing clapper (5) and install them onto the new clapper (5).
    - ii. Line up the holes and replace the screws (10) using a Phillips head screwdriver.
- To replace the seat (2):
- h. Remove the screws (11). For 1-1/2" and 2" valves, use a Phillips head screwdriver.
  - i. Remove the existing seat (2) from the body of the valve (1).
  - j. Note: The O-ring (12) is installed into the groove of the seat (2). Apply lubricant (included in the Seat Replacement Kit) to the groove of the seat (2). Install the O-ring (12) into the groove of the seat (2).



The Viking Corporation, 210 N Industrial Park Drive, Hastings MI 49058

Telephone: 269-945-9501 Technical Services: 877-384-5464 Fax: 269-818-1680 Email: techsvcs@vikingcorp.com

- k. Install the new seat (2).
- l. Line up the holes and tighten the new screws (11) in a star-shaped pattern with a Phillips head screwdriver. Use a torque wrench and tighten to 48 in-lbs. for 1-1/2" and 2" valves.
- m. To re-install the cover (4), hand tighten the cap screws (9) and then tighten the screws in a star-shaped pattern.  
Note: Tighten a top and bottom screw first. For 1-1/2" and 2" valves, use a socket wrench with a 9/16" socket.

## 7. AVAILABILITY

The Viking Flow Control Valve is available through a network of domestic and international distributors. See the Viking Corp. Web site for closest distributor or contact The Viking Corporation.

## 8. GUARANTEES

For details of warranty, refer to Viking's current list price schedule or contact Viking directly.

	<h1 style="margin: 0;">TECHNICAL DATA</h1>	<p><b>FLOW CONTROL VALVE</b>  <b>MODEL J-1</b>  <b>1-1/2" &amp; 2" (DN40 &amp; DN50)</b></p>
---	--	--

The Viking Corporation, 210 N Industrial Park Drive, Hastings MI 49058  
 Telephone: 269-945-9501 Technical Services: 877-384-5464 Fax: 269-818-1680 Email: techsvcs@vikingcorp.com

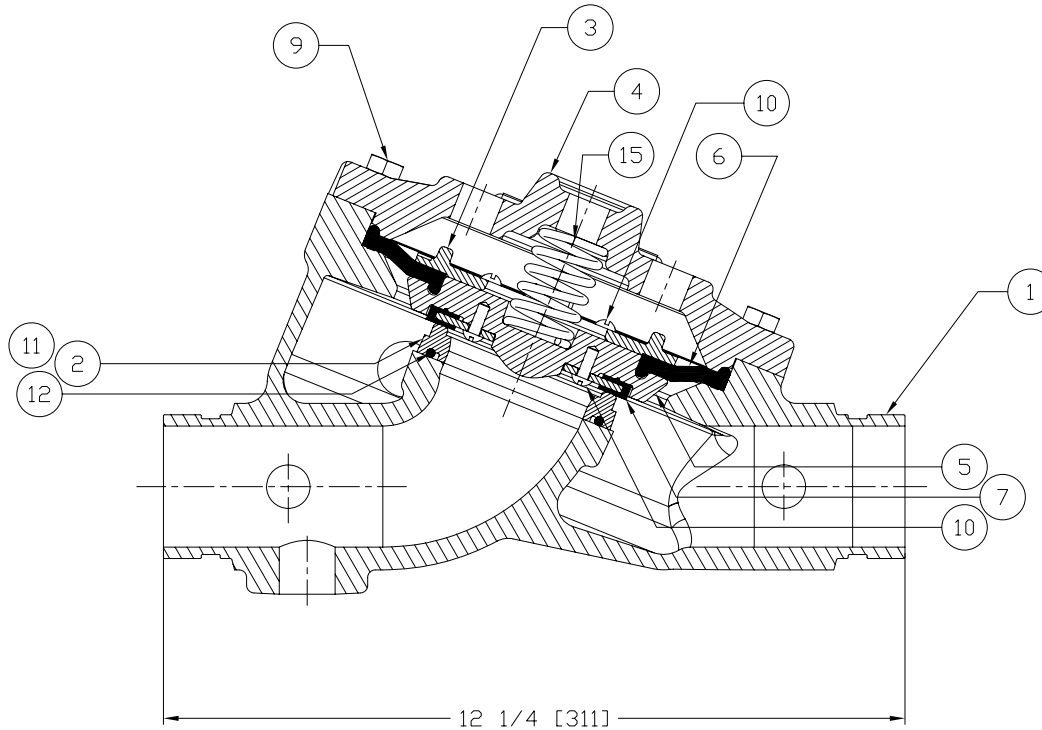

**Figure 3: Replacement Parts**

ITEM NO.	PART NUMBER	DESCRIPTION	MATERIAL	NO. REQ'D
1	--	Body	Ductile Iron Grade 65-45-12	1
2	*	Seat	Brass UNS-C84400	1
3	04224B	Ring Clamp, Upper Diaphragm	Brass UNS-C84400	1
4	--	Cover	Ductile Iron Grade 65-45-12	1
5	07046BN	Clapper	Brass UNS-C84400	1
6	12055	Upper Diaphragm	EPDM - ASTM D-2000	1
7	04225B	Rubber Seat Assembly	EPDM - ASTM D-2000/Stainless Steel UNS-S30400	1
8	--	Data Plate	Aluminum Etched	1
9	05855A	Screw, H.H.C., 3/8-16 x 1-1/8 (29 mm)	Steel SAE-Grade 5, ASTM A449	8
10	02494A	Screw, R.H., 10-24 x 1/2 (12.7 mm)	Stainless Steel UNS-S30200	8
11	*	Screw, R.H., 10-24 x 5/8 (16 mm)	Stainless Steel UNS-S30200	4
12	*	O-Ring	EPDM	1
13	01905A	Spring	Stainless Steel UNS-S30200	1
-- Indicates replacement part not available				
* Indicates part available only in sub-assembly listed below				
<b>SUB-ASSEMBLY</b>				
3, 5-7, 9, 10	13498	Clapper Assembly Kit		
2, 11-12	14711-2	Seat Replacement Kit*		
*Note: Includes O-ring lubricant to be added to ring groove in seat.				