



TECHNICAL DATA

FLOW CONTROL VALVE MODEL J-2 HALAR® COATED 2-1/2" - 8" (DN65 - DN200)

The Viking Corporation, 210 N Industrial Park Drive, Hastings MI 49058

Telephone: 269-945-9501 Technical Services: 877-384-5464 Fax: 269-818-1680 Email: techsvcs@vikingcorp.com

1. DESCRIPTION

The Viking Flow Control Valve is a quick opening, differential diaphragm flood valve with a spring loaded floating clapper.

The Flow Control Valve can be used to facilitate manual or automatic on/off control. It can also be used to control water pressure or flow rates. As an on/off control valve, it is used on Deluge Systems, Sprinkler Systems or to automatically fill tanks or reservoirs. The Flow Control Valve can be used as a pressure reducing valve to limit or conserve water flow. The valve is an integral part of the Viking Firecycle® System.

Features

I. VALVE:

1. Field replaceable Diaphragm and Seat Rubbers
2. Designed for installation in the horizontal or vertical position
3. Compatible with Hydraulic, (see Figures 3-6) Pneumatic, and/or Electric Detection Systems
4. Designed to be reset without opening the valve.
5. Can be trimmed to automatically reset electrically or manually.

II. HALAR COATING:

1. Exceeds performance of Epoxy Coating or Kynar Coating
2. Mechanical strength and toughness
3. High thermal stability
4. High dielectric strength
5. Resistant to most chemicals and solvents
6. Resistant to cobalt 60 radiation
7. All wetted surfaces are coated including pipe threads



DESCRIPTION	NOMINAL SIZE	PART NUMBER	FRICTION LOSS*	CV FACTOR	SHIPPING WEIGHT
Threaded					
NPT 65mm	2½"	12406Q/B	12 ft. (3.6 m)	155	66 lbs. (30 kg)
Flange/Flange					
Flange Drilling					
ANSI	3"	12017Q/B	22 ft. (6.7 m)	198	81 lbs. (37 kg)
ANSI	4"	11977Q/B	21 ft. (6.4 m)	416	125 lbs. (57 kg)
ANSI	6"	11979Q/B	39 ft. (11.9 m)	884	235 lbs. (107 kg)
ANSI	8"	11994Q/B	57 ft. (17.4 m)	1500	405 lbs. (184 kg)
PN10/16	DN80	12029Q/B	22 ft. (6.7 m)	198	81 lbs. (37 kg)
PN10/16	DN100	11982Q/B	21 ft. (6.4 m)	416	125 lbs. (57 kg)
PN10/16	DN150	11980Q/B	39 ft. (11.9 m)	884	235 lbs. (107 kg)
PN10	DN200	11998Q/B	57 ft. (17.4 m)	1500	405 lbs. (184 kg)
PN16	DN200	12002Q/B	57 ft. (17.4 m)	1500	405 lbs. (184 kg)
Flange/Groove					
Flange Drilling / Pipe O.D.					
ANSI / 89 mm	3"	12021Q/B	22 ft. (6.7 m)	198	73 lbs. (33 kg)
ANSI / 114 mm	4"	11976Q/B	21 ft. (6.4 m)	416	125 lbs. (57 kg)
ANSI / 168 mm	6"	11978Q/B			
PN10/16 / 89 mm	DN80	12646Q/B	22 ft. (6.7 m)	198	73 lbs. (33 kg)
PN10/16 / 114 mm	DN100	12647Q/B	21 ft. (6.4 m)	416	125 lbs. (57 kg)
PN10/16 / 165 mm	DN150	12643Q/B	39 ft. (11.9 m)	884	235 lbs. (107 kg)
PN10/16 / 168 mm	DN150	11978Q/B	39 ft. (11.9 m)	884	235 lbs. (107 kg)
Groove/Groove					
Pipe O.D.					
73 mm	2½" / 65mm	12408Q/B	12 ft. (3.6 m)	155	66 lbs. (30 kg)
76 mm	DN80	12732Q/B	12 ft. (3.6 m)	155	66 lbs. (30 kg)
89 mm	3" / DN80	12025Q/B	22 ft. (6.7 m)	198	65 lbs. (29 kg)
114 mm	4" / DN100	11517Q/B	21 ft. (6.4 m)	416	125 lbs. (57 kg)
165 mm	DN150	11913Q/B	39 ft. (11.9 m)	884	235 lbs. (107 kg)
168 mm	6" / DN150	11528Q/B	39 ft. (11.9 m)	884	235 lbs. (107 kg)
219 mm	8" / DN200	11119Q/B	57 ft. (17.4 m)	1500	405 lbs. (184 kg)

$$Q = C_v \sqrt{\frac{\Delta P}{S}}$$

Q= Flow
 Cv= Flow Factor (GPM/1 PSI ΔP)
 ΔP= Pressure Loss through Valve
 S= Specific Gravity of Fluid

* Expressed in equivalent length of pipe based on Hazen & Williams Formula C = 120.

Table 1 - Valve Part Numbers and Specifications



TECHNICAL DATA

FLOW CONTROL VALVE MODEL J-2 HALAR® COATED 2-1/2" - 8" (DN65 - DN200)

The Viking Corporation, 210 N Industrial Park Drive, Hastings MI 49058

Telephone: 269-945-9501 Technical Services: 877-384-5464 Fax: 269-818-1680 Email: techsvcs@vikingcorp.com

2. LISTINGS AND APPROVALS:

UL Listed - Guide No. VLFT & VLLA
C-UL Listed
FM Approved - On-Off Multi Cycle Sprinkler Systems
NYC Department of Buildings Approved - MEA 89-92-E Vol. XXXI
ABS Certificate number: 04-CH557068-X

3. TECHNICAL DATA

Specifications:

Style: Straight through pattern
Connections available: See Table 1.
Hydrostatically tested to 500 PSI (34.5 bar) at factory
Priming Chamber supply restriction (required): 0.125" (3.1 mm).
Color: Black
Friction Loss: See Table 1.
Cv Factor: See Table 1.

Material Standards:

Refer to Figure 7.
Halar® Coating Specification (SPF-2-Q06): See Figure 2
Electroless Nickel and Tin Plating Specifications (SPF02-J07): See Figure 2.
Teflon Coating Specification (SPF02-N05): See Figure 2.

Ordering Information:

See Table 1.
Available Since 2002

Accessories:

- A Conventional Trim package for use with the Model J-2 Flow Control Valve. The trim package includes all required trim components and all fittings and nipples shown on the Viking Model J Flow Control Valve Conventional Trim Chart for the valve used. Trim Charts are provided in trim packages and the *Viking Engineering and Design Data* book. For optional pre-assembled "modular" trim packages, refer to the Viking list price schedule or contact the manufacturer.
- Auxiliary Components are required for specific valve functions. For complete operating trim requirements refer to System Data for the system used. System Data is provided in the *Viking Engineering and Design Data* book.

NOTE: FOR PART NUMBERS OF ACCESSORIES, REFER TO VIKING LIST PRICE SCHEDULE.

Systems with water working pressures above 175 PSI (1 207 kPa) may require extra-heavy pattern fittings. Viking Model H-2 Flow Control Valve flanges are Ductile Iron ANSI B16.42 Class 150 with a maximum water working pressure of 250 PSI. ANSI B16.42 Class 150 flanges are NOT compatible with ANSI Class 250 or Class 300 flanges. To mate the Model H-2 Flow Control Valve with ANSI Class 250 or Class 300 flanges, use the grooved-outlet style valve, installed with listed grooved/flange adapters of the appropriate pressure rating. For piping with grooved connections, the grooved-outlet style valve may be installed with listed grooved couplings of the appropriate pressure rating.

Viking Technical Data may be found on
The Viking Corporation's Web site at
<http://www.vikinggroupinc.com>.
The Web site may include a more recent
edition of this Technical Data Page.

4. INSTALLATION

A. General Instruction

1. Viking Flow Control Valves may be installed in the horizontal or vertical position.

NOTE: FOR POSITIONS OTHER THAN VERTICAL, MINOR MODIFICATION OF TRIM MAY BE REQUIRED TO FACILITATE DRAINAGE FROM OUTLET CHAMBER OF THE FLOW CONTROL VALVE (CONSULT MANUFACTURER).

2. The valve must be installed in an area not subject to freezing temperatures or physical damage.
3. The valve must be trimmed according to current Viking Model J Conventional Trim Charts and appropriate instructions for the system used. Trim Charts are printed in the *Viking Engineering and Design Data* book, and are provided with trim packages. For additional trim connections, refer to technical data describing the system being installed.
4. The priming line must be connected upstream of the system water supply main control valve or to a constant source of water at a pressure equal to the system water supply.
5. After the Flow Control Valve is set, operation of the Flow Control Valve requires the release of priming water from the priming chamber. This may be by automatic or manual operation of the release system. Viking Flow Control Valves are compatible with hydraulic, pneumatic, and electric release systems. For specific Trim arrangements, refer to Trim Charts, Technical Data, and System Data describing the system being installed. Trim Charts are printed in the *Viking Engineering and Design Data* book and are provided with trim packages. Technical Data and System Data sheets are printed in the *Viking Engineering and Design Data* book.
 - a. Hydraulic Release Systems: See Figures 3-6 for the maximum allowable elevation of hydraulic release piping above the Flow Control Valve. If the maximum height of hydraulic release piping exceeds the limit shown in Figures 3-6 for the valve used, use a Pneumatic or Electric Release System.
 - b. Pneumatic Release Systems: A Viking Pneumatic Actuator is required between the release system connection provided on flow Control Trim and pneumatic release system piping.



TECHNICAL DATA

**FLOW CONTROL VALVE
MODEL J-2 HALAR® COATED
2-1/2" - 8" (DN65 - DN200)**

The Viking Corporation, 210 N Industrial Park Drive, Hastings MI 49058

Telephone: 269-945-9501 Technical Services: 877-384-5464 Fax: 269-818-1680 Email: techsvcs@vikingcorp.com

CAUTION: WHEN RELEASING DEVICES CAPABLE OF AUTOMATICALLY RESETTING ARE USED ON THE PNEUMATIC RELEASE SYSTEM OF A FLOW CONTROL VALVE, VIKING MODEL F DELUGE VALVE CONVENTIONAL TRIM, COMPLETE WITH PORV, IS REQUIRED. THIS ARRANGEMENT WILL NOT ALLOW THE FLOW CONTROL VALVE TO AUTOMATICALLY RESET.

- c. Electric Release: Solenoid Valves, Release Control Panels, and Electrical Detectors must be compatible. Consult appropriate listing and/or approval guides.
6. The Viking Flow Control Valve can be trimmed to automatically reset electrically or manually. For specific Trim arrangements refer to System Data describing the system being installed.

NOTE: DO NOT INSTALL ANY RELEASING DEVICE, OR VALVE USED TO AUTOMATICALLY RESET THE FLOW CONTROL VALVE, ON PNEUMATIC RELEASE PIPING.

For pneumatic release systems, any releasing valve or device used to automatically reset the Flow Control Valve must be installed in the trim piping between the Pneumatic Actuator and the priming chamber outlet.

CAUTION: OPERATION OF VIKING FLOW CONTROL VALVES BY PRESSURIZING THE PRIMING CHAMBER WITH AIR OR ANY OTHER PRESSURIZED GAS IS NOT RECOMMENDED OR APPROVED.

B. Placing the Valve in Service

1. Verify:
 - a. The system Main Water Supply Control Valve (D.1) is closed and the Halar® Coated Flow Control Valve is trimmed according to current Viking Trim Charts and schematic drawings for the system used.
 - b. The system has been properly drained.
 - c. Auxiliary Drain Valve (B.12) is open.
 - d. The Emergency Release (B.8) is closed.
 - e. The system water supply piping is pressurized up to the closed Main Water Supply Control Valve (D.1) and the priming line is pressurized up to the closed Priming Valve (B.1).
2. For Systems equipped with:
 - a. Hydraulic Release Systems:
 - i. Verify that all releasing devices are set and that any Inspector's Test Valve and/or auxiliary drain valves are closed.
 - ii. Open Priming Valve (B.1).
 - iii. Proceed to step 3.
 - b. Pneumatic Release Systems:
 - i. Set the release system.
 - ii. Open Priming Valve (B.1).
 - iii. Proceed to step 3.
 - c. Electric Release Systems:
 - i. Open Priming Valve (B.1).
 - ii. Set the electric release system.
 - iii. Proceed to step 3.
3. Open Flow Test Valve (B.10).
4. Partially open Main Water Supply Control Valve (D.1).
5. When full flow develops from the Flow Test Valve (B.10), close the Flow Test Valve (B.10). Verify that there is no flow from the open Auxiliary Drain Valve (B.12).
6. Close Auxiliary Drain Valve (B.12).
7. Fully open and secure the Main Water Supply Control Valve (D.1).
8. Verify that the Alarm Shut-off Valve is open and that all other valves are in their normal operating position.
9. Depress the plunger of Drip Check (B.13). No water should flow from the Drip Check (B.13) when the plunger is pushed.
10. Check for, and repair all leaks.
11. On new installations, those systems that have been placed out of service or where new equipment has been installed, trip test the system to verify that all equipment functions properly. Refer to INSPECTION, TESTS AND MAINTENANCE, paragraph 6.B Annual Tests instructions.

CAUTION: PERFORMING A TRIP TEST RESULTS IN OPERATION OF THE FLOW CONTROL VALVE. WATER WILL FLOW INTO THE SPRINKLER PIPING. TAKE NECESSARY PRECAUTIONS TO PREVENT DAMAGE.

12. After completing a trip test, perform SEMI-ANNUAL maintenance.

C. Automatic Resetting

To automatically reset the Flow Control Valve after it has operated:

1. DO NOT close the water supply main control valve. The Priming Valve (B.1) must be OPEN.
2. Automatically or manually reset any open devices on the hydraulic release system to stop all flow of water out of the priming chamber.



TECHNICAL DATA

**FLOW CONTROL VALVE
MODEL J-2 HALAR® COATED
2-1/2" - 8" (DN65 - DN200)**

The Viking Corporation, 210 N Industrial Park Drive, Hastings MI 49058

Telephone: 269-945-9501 Technical Services: 877-384-5464 Fax: 269-818-1680 Email: techsvcs@vikingcorp.com

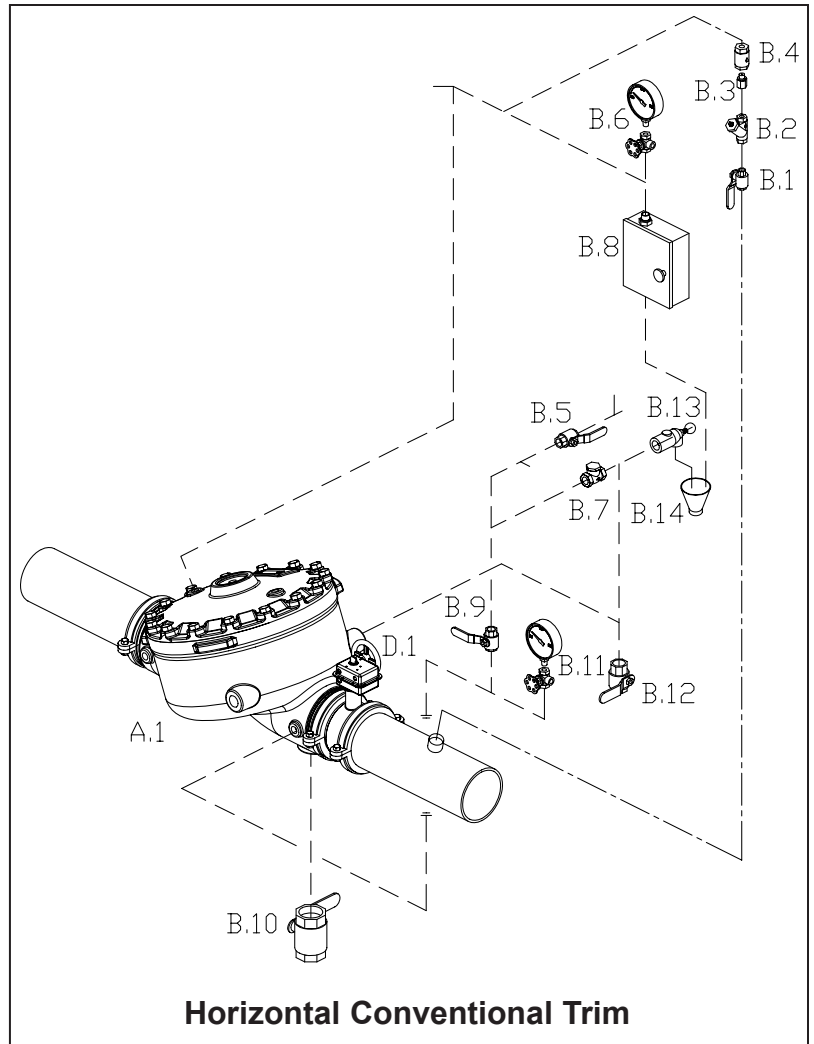
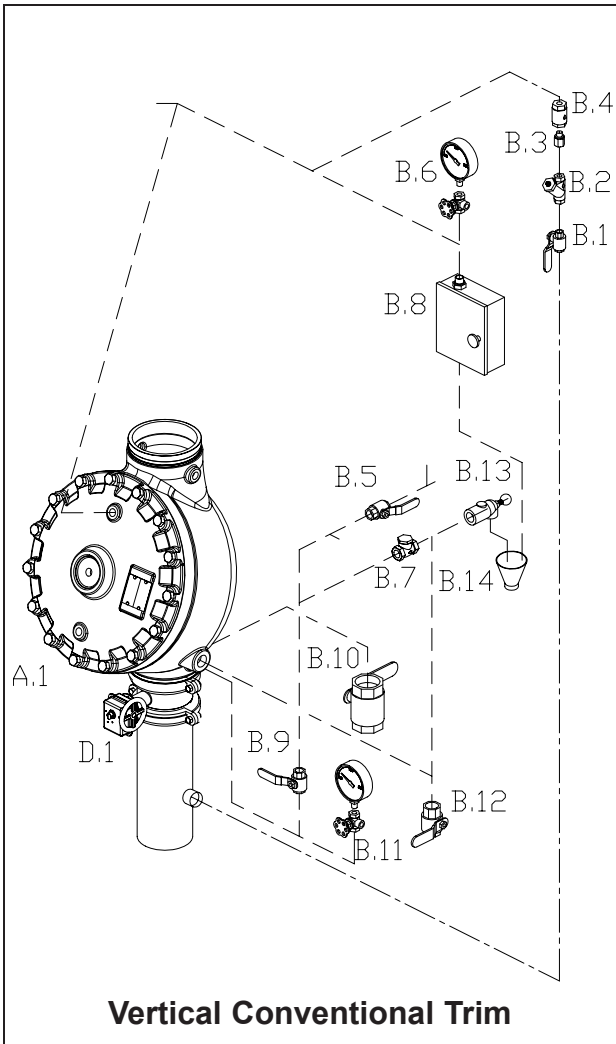

----- Dashed lines indicate Nipples and Fittings included with Trim
 - - - - - Phantom lines indicate Piping required but not included with Trim

Figure 1 - Trim Components

- | | | | |
|-----|--|------|---|
| A.1 | Flow Control Valve | B.8 | Emergency Release |
| B.1 | Priming Valve (Normally Open) | B.9 | Alarm Test Valve (Normally Closed) |
| B.2 | Strainer | B.10 | Flow Test Valve (Normally Closed) |
| B.3 | 1/16" Restricted Orifice | B.11 | Water Supply Pressure Water Gauge and Valve |
| B.4 | Spring Loaded Check Valve | B.12 | Auxiliary Drain Valve (Normally Closed) |
| B.5 | Alarm Shut-Off Valve (Normally Open) | B.13 | Drip Check Valve |
| B.6 | Priming Pressure Water Gauge and Valve | B.14 | Drain Cup |
| B.7 | Drain Check Valve | D.1 | Water Supply Control Valve |



TECHNICAL DATA

**FLOW CONTROL VALVE
MODEL J-2 HALAR® COATED
2-1/2" - 8" (DN65 - DN200)**

The Viking Corporation, 210 N Industrial Park Drive, Hastings MI 49058

Telephone: 269-945-9501 Technical Services: 877-384-5464 Fax: 269-818-1680 Email: techsvcs@vikingcorp.com

CAUTION: RESETTING OR CLOSING RELEASING DEVICES OR VALVES ON PNEUMATIC RELEASE PIPING WILL NOT AUTOMATICALLY CAUSE THE FLOW CONTROL VALVE TO RESET.

DO NOT install any releasing device or valve, used to automatically reset the Flow Control Valve, on pneumatic release piping.

3. System supply pressure will enter the priming chamber through the restricted priming line connected to the priming chamber inlet.
4. When the combined force of spring pressure and system supply pressure entering the priming chamber overcomes the velocity pressure of water flowing through the valve, the clapper will close.
5. Flow through the valve will stop.
6. To reactivate the system, open a releasing device. Priming water will escape from the priming chamber faster than it is replaced through the restricted priming line, allowing the Flow Control Valve to open.

D. Valve Removed From Service

NOTE: WHEN A VALVE HAS BEEN REMOVED FROM SERVICE AND IS SUBJECT TO FREEZING OR WILL BE OUT OF SERVICE FOR AN EXTENDED PERIOD OF TIME, ALL WATER MUST BE REMOVED FROM THE PRIMING CHAMBER, TRIM PIPING, WATER SUPPLY PIPING AND OTHER TRAPPED AREAS.

5. OPERATION (Refer to Figure 7.)

The Model J-2 Flow Control valve has an inlet chamber, an outlet chamber, and a priming chamber. The inlet chamber and outlet chamber are separated from the priming chamber by the clapper (5) and diaphragm (6). System pressure enters the priming chamber through a restricted priming line (trim) equipped with a check valve.

In the SET position:

System pressure is trapped in the priming chamber to hold clapper (5) on seat (2) due to area differential of the clapper, and spring (15) pressure. Clapper (5) separates the inlet from the outlet, keeping the system piping dry.

In fire conditions:

When the release system operates, pressure is released from the priming chamber faster than it is supplied through the restricted priming line. Water supply pressure in the inlet chamber forces the clapper (5) off from seat (2) allowing water to flow through the outlet and into the system piping and alarm devices.

To automatically reset, flow of water out of the priming chamber is stopped. This can be done manually (by closing a valve in the hydraulic release piping), or electrically (by closing a solenoid valve in the hydraulic release piping). When the combined force of spring (15) pressure and system supply pressure entering the priming chamber overcomes the velocity pressure of water flowing through the valve, the clapper (5) will close. Flow through the valve will stop.

6. INSPECTIONS, TESTS AND MAINTENANCE

A. Inspection

It is imperative that the system be inspected and tested on a regular basis. The frequency of the inspections may vary due to contaminated water supplies, corrosive water supplies or corrosive atmospheres. Also, the alarm devices, detection systems or other connected trim may require a more frequent schedule. For minimum maintenance and inspection requirements, refer to NFPA 25. In addition, the Authority Having Jurisdiction may have additional maintenance, testing, and inspection requirements that must be followed. The following recommendations are minimum requirements. (For additional information, refer to Viking Trim Charts and System Data describing systems with the release system used.)

Weekly - Weekly visual inspection of the Viking Flow Control Valve is recommended.

1. Verify that the Main Water Supply Control Valve (D.1) is open and that all other valves are in their normal operating position and appropriately secured.
2. Check for signs of mechanical damage, leakage, and/or corrosive activity. If detected, perform maintenance as required. If necessary, replace the device.
3. Verify that the valve and trim are adequately heated and protected from freezing and physical damage.

B. Tests

Quarterly - Quarterly testing of water flow alarms and performance of a Main Drain Test is recommended and may be required by the Authority Having Jurisdiction.

I. Water Flow Alarm Test

1. Notify the Authority Having Jurisdiction and those in the area affected by the test.
2. To test the local electric alarm (if provided) and/or mechanical water motor alarm (if provided), OPEN the alarm test valve in the Flow Control Valve trim.
 - a. Electric alarm pressure switches (if provided) should activate.
 - b. Electric local alarms should be audible.
 - c. The local water motor gong should be audible.



TECHNICAL DATA

**FLOW CONTROL VALVE
MODEL J-2 HALAR® COATED
2-1/2" - 8" (DN65 - DN200)**

The Viking Corporation, 210 N Industrial Park Drive, Hastings MI 49058

Telephone: 269-945-9501 Technical Services: 877-384-5464 Fax: 269-818-1680 Email: techsvcs@vikingcorp.com

- d. If equipped with remote station alarm signaling devices, verify that alarm signals were received.
3. When testing is complete, CLOSE the alarm test valve.
4. Verify:
 - a. All local alarms stop sounding and alarm panels (if provided) reset.
 - b. All remote station alarms reset.
 - c. Supply piping to water motor alarm properly drains.
5. Verify that the alarm shut-off valve is OPEN, and the alarm test valve is CLOSED.
6. Verify that the outlet chamber is free of water. No water should flow from the Drip Check (B.13) when the plunger is pushed.
7. Notify the Authority Having Jurisdiction and those in the affected area that testing is complete.

II. Main Drain Test

1. Notify the Authority Having Jurisdiction and those in the area affected by the test.
2. Record pressure reading from the water supply pressure gauge.
3. Verify that the outlet chamber of the Flow Control Valve is free of water. No water should flow from the Drip Check (B.13) when the plunger is pushed.
4. Fully OPEN the Flow Test Valve (B.10).
5. When a full flow is developed from the Flow Test Valve (B.10), record the residual pressure from the water supply pressure gauge.
6. When the test is complete, SLOWLY CLOSE the Flow Test Valve (B.10).
7. Compare test results with previous flow information. If deterioration of the water supply is detected, take appropriate steps to restore adequate water supply.
8. Verify:
 - a. Normal water supply pressure has been restored to the inlet chamber, the priming chamber, and the release system. The pressure on the priming chamber water pressure gauge should equal the system water supply pressure.
 - b. All alarm devices, and valves are secured in normal operating position.
9. Notify the Authority Having Jurisdiction that the test is complete. Record and/or provide notification of test results as required by the Authority Having Jurisdiction.

Annual - Annual Trip Tests are recommended.

CAUTION: PERFORMING THIS TEST RESULTS IN OPERATION OF THE FLOW CONTROL VALVE. WATER WILL FLOW INTO THE SPRINKLER PIPING AND FROM ANY OPEN SPRINKLERS AND/OR NOZZLES. TAKE NECESSARY PRECAUTIONS TO PREVENT DAMAGE.

1. Notify the Authority Having Jurisdiction and those in the area affected by the test.
2. Fully open the Flow Test Valve (B.10) to flush away any accumulation of foreign material.
3. Close the Flow Test Valve (B.10).
4. Trip the system by operating the release system. Allow a full flow to pass through the Flow Control Valve. Water flow alarms should operate.

When test is complete:

5. For Flow Control Valves equipped with:
 - a. Hydraulic or Electric Release:
 - i. Re-set the Release System. Pressure in the priming chamber should gradually be restored. Flow through the Flow Control Valve should stop.
 - ii. Proceed to step 6.
 - b. Pneumatic Release Systems:
 - i. Close the Main Water Supply Control Valve (D.1) and Priming Valve (B.1).
 - ii. Open Auxiliary Drain Valve (B.12).
 - iii. Open all system main drains and auxiliary drains. Allow the system to drain completely. Proceed to step 6.
6. Perform SEMI-ANNUAL maintenance. Refer to paragraph 6.B.II - Semi-Annual Maintenance.
7. Place the system in service. Refer to Item 4.B, INSTALLATION: PLACING THE VALVE IN SERVICE.

NOTE: VALVES SUPPLIED BY BRACKISH WATER, SALT WATER, FOAM, FOAM/WATER SOLUTION, OR ANY OTHER CORROSIVE WATER SUPPLY, SHOULD BE FLUSHED WITH GOOD QUALITY FRESH WATER BEFORE BEING RETURNED TO SERVICE.

8. Notify the Authority Having Jurisdiction that the test is complete. Record and/or provide notification of test results as required by the Authority Having Jurisdiction.



TECHNICAL DATA

**FLOW CONTROL VALVE
MODEL J-2 HALAR® COATED
2-1/2" - 8" (DN65 - DN200)**

The Viking Corporation, 210 N Industrial Park Drive, Hastings MI 49058

Telephone: 269-945-9501 Technical Services: 877-384-5464 Fax: 269-818-1680 Email: techsvcs@vikingcorp.com

B. Maintenance

NOTICE: THE OWNER IS RESPONSIBLE FOR MAINTAINING THE FIRE PROTECTION SYSTEM AND DEVICES IN PROPER OPERATING CONDITION. THE FLOW CONTROL VALVE MUST BE KEPT FROM FREEZING CONDITIONS AND PHYSICAL DAMAGE THAT COULD IMPAIR ITS OPERATION.

Where difficulty in performance is experienced, the valve manufacturer or his authorized representative shall be contacted if any field adjustment is to be made.

WARNING: ANY SYSTEM MAINTENANCE WHICH INVOLVES PLACING A CONTROL VALVE OR DETECTION SYSTEM OUT OF SERVICE MAY ELIMINATE THE FIRE PROTECTION CAPABILITIES OF THAT SYSTEM. PRIOR TO PROCEEDING, NOTIFY ALL AUTHORITIES HAVING JURISDICTION. CONSIDERATION SHOULD BE GIVEN TO EMPLOYMENT OF A FIRE PATROL IN THE AFFECTED AREAS.

I. After Each Operation:

1. Sprinkler systems that have been subjected to a fire must be returned to service as soon as possible. The entire system must be inspected for damage, and repaired or replaced as necessary.
2. Flow Control Valves and trim that have been subjected to brackish water, salt water, foam, foam/water solution, or any other corrosive water supply, should be flushed with good quality fresh water before being returned to service.
3. Perform SEMI-ANNUAL maintenance after every operation.

II. Semi-Annual Maintenance:

1. Remove the system from service. (See release system description and technical data for additional information.)
 - a. Close the Main Water Supply Control Valve (D.1) and Priming Valve (B.1).
 - b. Open the Auxiliary Drain Valve (B.12). Allow the outlet chamber of the Flow Control Valve to drain completely.
 - c. Release the pressure in the priming chamber by opening the Emergency Release (B.8) Valve.
2. Inspect all trim for signs of corrosion and/or blockage. Clean and/or replace as required.
3. Clean and/or replace all strainer screens.
4. Refer to Item 4.B, INSTALLATION: PLACING THE VALVE IN SERVICE.

III. Every Fifth Year

1. Internal inspection of Flow Control Valves is recommended every five years unless inspections and tests indicate more frequent internal inspections are required. Refer to DISASSEMBLY instructions provided below.
2. Internal inspection of strainers and restricted orifices is recommended every five years unless inspections and tests indicate more frequent internal inspections are required.
3. Record and provide notification of inspection results as required by the Authority Having Jurisdiction.

IV. Halar® Coating Repair

If the Halar® coating becomes chipped, immediately repair the damaged area to inhibit the potential for corrosion. Follow instructions below:

1. Wipe clean and prepare the area to be repaired.
2. Using a handheld torch, gently heat the Halar® coating around the area needing repair to the melting point of the Halar®. (Caution: Wear protective air filter mask)
3. Allow the heated Halar® to flow together.
4. Allow the coating to cool.

V. Valve Disassembly (Refer to Figure 7.)

1. Remove the valve from service
 - a. Close the Main Water Supply Control Valve (D.1) and Priming Valve (B.1).
 - b. Open the Auxiliary Drain Valve (B.12).
 - c. Release the pressure in the priming chamber by opening the Emergency Release (B.8) Valve.
 - d. Disconnect and remove trim from the cover (4).
 - e. Remove the cover (4): Remove each of the cap screws (9). (Note: It is recommended to remove a top and bottom screw after removing the other screws first.)
 - i. For 2-1/2" - 4" valves, use a socket wrench with a 3/4" socket.
 - ii. For 6" and 8" valves, use a socket wrench with a 15/16" socket.
 - f. Lift the cover (4) from the body (1) and the spring (13) from the clapper (5).

VI. Installing Replacement Parts and Valve Reassembly (Refer to Figure 7.)

- a. To replace the spring (13) only:
 - i. It can be difficult to hold the Spring (13) in place while replacing the Cover (4). A method to make this easier is to take the Cover (4) and place a screwdriver through the Cover (4) and place the Spring (13) onto the screwdriver, and re-install the Cover (4).



TECHNICAL DATA

**FLOW CONTROL VALVE
MODEL J-2 HALAR® COATED
2-1/2" - 8" (DN65 - DN200)**

The Viking Corporation, 210 N Industrial Park Drive, Hastings MI 49058

Telephone: 269-945-9501 Technical Services: 877-384-5464 Fax: 269-818-1680 Email: techsvcs@vikingcorp.com

- b. To replace the entire clapper assembly (3, 5, 6, 7, & 10), which is ordered preassembled:
 - i. Remove the existing clapper assembly (3, 5, 6, 7, & 10) by placing a flat head screwdriver between the body of the valve (1) and the upper diaphragm (6) and then lifting the clapper assembly from the valve body (1).
 - ii. Inspect the seat (2). If replacement is necessary, see step h below.

NOTE: Prior to reassembly, flush the valve of all foreign matter. The valve seat (2) must be clean and free from all marks and scratches.

- iii. Install the new clapper assembly kit (3, 5, 6, 7, & 10) into the valve body (1).

If the entire clapper assembly does not need to be replaced, each of the parts of the clapper assembly kit are offered individually for replacement.

- c. First, remove the circle of screws (10):
 - i. For 2-1/2" and 3" valves, use a Phillips head screwdriver.
 - ii. For 4" valves, use a socket wrench with a 1/2" socket.
 - iii. For 6" valves, use a socket wrench with a 9/16" socket.
 - iv. For 8" valves, use a 5/16" Allen wrench.
- d. To replace the clamp ring (3):
 - i. For 3" valves only, fit the grooved seat of the new clamp ring (3) into the grooved seat of the upper diaphragm (6). For all other valve sizes, place the clamp ring (3) on the clapper (5).
 - ii. Line up the holes and replace the screws (10) using the tools indicated in step c above.
- e. To replace the upper diaphragm (6):
 - i. Remove the existing clamp ring (3) (step d above).
 - ii. Remove the existing upper diaphragm (6). Note: For 3" valves only, the raised edge of the upper diaphragm (6) fits into the grooved seat of the clamp ring (3). For all other valve sizes, the raised edge of the upper diaphragm (6) faces down toward the grooved seat of the clapper (5).
 - iii. Install the new upper diaphragm (6) and reinstall the clamp ring (3).
 - iv. Line up the holes and replace the screws (10) using the tools indicated in step d above.
- f. To replace the rubber seat assembly (7):
 - i. The clapper clapper assembly (3, 5, 6, 7, & 10) must be removed from the valve (step b above).
 - ii. Turn the clapper (5) over and remove the circle of screws (10) using the tools indicated in step c above.
 - iii. The raised edge on the center of the rubber seat faces down into the grooved seat of the clapper (5).
 - iv. Line up the holes and replace the screws (10) using the tools indicated in step c above.
- g. To replace the clapper (5):
 - i. Remove the clamp ring (3), the upper diaphragm (6), and the rubber seat assembly (7) from the existing clapper (5) and install them onto the new clapper (5).
 - ii. Line up the holes and replace the screws (10) using the tools indicated in step c above.
- h. To replace the seat (2):
 - i. Remove the screws (11):
 - i. For 2-1/2" and 3" valves, use a Phillips head screwdriver.
 - ii. For 4" valves, use a 5/32" Allen wrench.
 - iii. For 6" and 8" valves, use a 3/16" Allen wrench.
 - j. Remove the existing seat (2) from the body of the valve (1).
 - k. Note: The O-ring (12) is installed into the groove of the seat (2). Apply lubricant (included in the Seat Replacement Kit) to the groove of the seat (2). Install the O-ring (12) into the groove of the seat (2).
 - l. Install the new seat (2).
- m. Line up the holes and tighten the new screws (11) in a star-shaped pattern with a torque wrench (see step h above), using 48 in-lbs. for 2-1/2" - 4" valves, and 140 in-lbs. for 6" and 8" valves.
- n. To re-install the cover (4), hand tighten the cap screws (9) and then tighten the screws in a star-shaped pattern. Note: Tighten a top and bottom screw first.
 - i. For 2-1/2" - 4" valves, use a socket wrench with a 3/4" socket.
 - iii. For 6" and 8" valves, use a socket wrench with a 15/16" socket.

7. AVAILABILITY

The Viking Flow Control Valve is available through a network of domestic and international distributors. See the Viking Corp. Web site for closest distributor or contact The Viking Corporation.

8. GUARANTEES

For details of warranty, refer to Viking's current list price schedule or contact Viking directly.

	<h1 style="margin: 0;">TECHNICAL DATA</h1>	<p>FLOW CONTROL VALVE MODEL J-2 HALAR® COATED 2-1/2" - 8" (DN65 - DN200)</p>
---	--	---

The Viking Corporation, 210 N Industrial Park Drive, Hastings MI 49058
Telephone: 269-945-9501 Technical Services: 877-384-5464 Fax: 269-818-1680 Email: techsvcs@vikingcorp.com

Figure 2 - Coating and Plating Specifications

Halar® Coating specification: Viking Specification SPF02-Q06 - Ethylene and Chlorotrifluoroethylene (Powder)

Total Thickness: .008"-.010" (.20 mm - .25 mm) applied as follows:

1. Parts are cleaned and sandblasted for proper adhesion and performance
2. Primer base powder and Halar® clear powder coat applied using Electrostatic Spray system
3. Powder is fusion bonded and cured in oven, and allowed to cool

Electroless Nickel Plating Specification: Viking Specification SPF02-J07

Total thickness: .002"-.0025" (.05 mm - .06 mm) applied for corrosion resistance as follows:

1. Parts are cleaned and rinsed for proper adhesion
2. Parts are chemically activated for adhesion of plating
3. Finish plate with .002"-.0025" (.05 mm - .06 mm) Electroless Nickel Phosphorus plating
4. Apply .0002" - .0003" (.005 mm - .007 mm) Tin/Lead plating to seat/rubber contact surface

Teflon® Coating Specification: Viking Specification SPF02-N05 - Teflon® Powder Coating

Total thickness: .002" - .0025" (.05 mm - .06 mm) Teflon® Powder Coating applied as follows:

1. Parts are cleaned and burned off in oven
2. Parts are etched for adhesion by grit blasting
3. Teflon® Powder is electrostatically applied to .002"-.0025" (.05 mm - .06 mm)
4. Powder is fusion bonded and cured in oven, and allowed to cool

Halar® is a registered trademark of Ausimont USA, Inc.

Teflon® is a registered trademark of E.I. Dupont Corp.

Table 2 - Trim Piping Materials Chart	
VALVE CONTROLLING:	TRIM PIPING MATERIAL
Fresh Water Only	Standard - See Note 1.
Sea Water Only AFFF/Sea Water Premix Solution ARC/Sea Water Premix Solution	316 Stainless Steel or 400 Monel. See Note 2 & 4.
AFFF/Fresh Water Premix Solution	Black Steel, Copper, Stainless Steel or 400 Monel. See Notes 3 & 4.
AFFF/Fresh Water Premix Solution	Black Steel, Copper, Stainless Steel or 400 Monel. See Notes 3 & 4.
AFFF Foam Concentrate in pipes 2" (DN50) & larger	Black Steel, Copper, Stainless Steel or 400 Monel. See Notes 3 & 4.
AFFF Foam Concentrate in pipes smaller than 2" (DN50)	Copper 316, Stainless Steel or 400 Monel. See Note 4.
ARC Foam Concentrate	Stainless Steel or 400 Monel. See Notes 4 & 5.

Note 1 - Standard Trim sets available from Viking consist of galvanized nipples and fittings. Includes ACCESSORY PACKAGE.

Note 2 - After operation, the valve & trim should be flushed with good quality fresh water before being returned to service.

Note 3 - Copper trim sets are not available from Viking. They may be manufactured by installer. Refer to Model J Flow Control Valve Trim Charts provided in the *Viking Engineering and Design Data* book for required configuration of trim, sizes and lengths of nipples and components required.

Note 4 - Monel trim sets are not available from Viking. They may be manufactured by installer. Refer to Model J Flow Control Valve Trim Charts provided in the *Viking Engineering and Design Data* book for required configuration of trim, sizes and lengths of nipples and components required.

Note 5 - Do NOT allow ARC Foam Concentrate to enter the priming chamber of the Flow Control Valve. When using the Halar® Coated Flow Control Valve as a Foam Concentrate Control Valve, refer to the *Viking Foam Engineering and Design Data* book for trim charts, technical data and special instructions.



TECHNICAL DATA

**FLOW CONTROL VALVE
MODEL J-2 HALAR® COATED
2-1/2" - 8" (DN65 - DN200)**

The Viking Corporation, 210 N Industrial Park Drive, Hastings MI 49058

Telephone: 269-945-9501 Technical Services: 877-384-5464 Fax: 269-818-1680 Email: techsvcs@vikingcorp.com

Maximum Allowable Pilot Heights for Select Equivalent Lengths of Hydraulic Release Piping

For Model J-1 Flow Control Valves with 1/8" (3.2 mm) Restricted Orifice

Graph is based on 1/2" (15 mm) pilot sprinklers installed on 1/2" (15 mm) schedule 40 galvanized release system piping.

If the maximum height of hydraulic release piping exceeds the limits shown on the graph, use Pneumatic or Electric Release System.

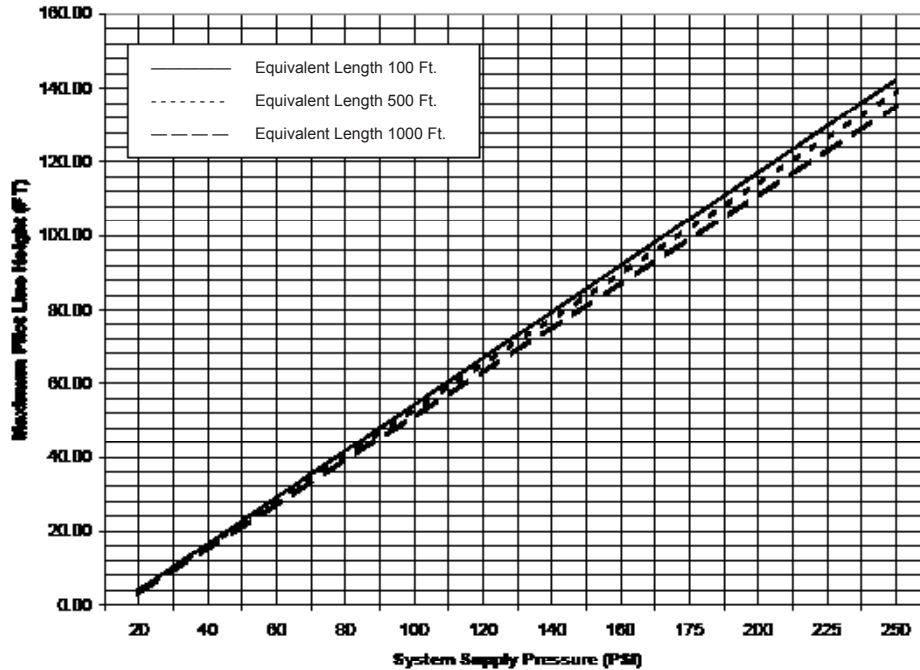

Figure 3: 2-1/2" & 3" Valves

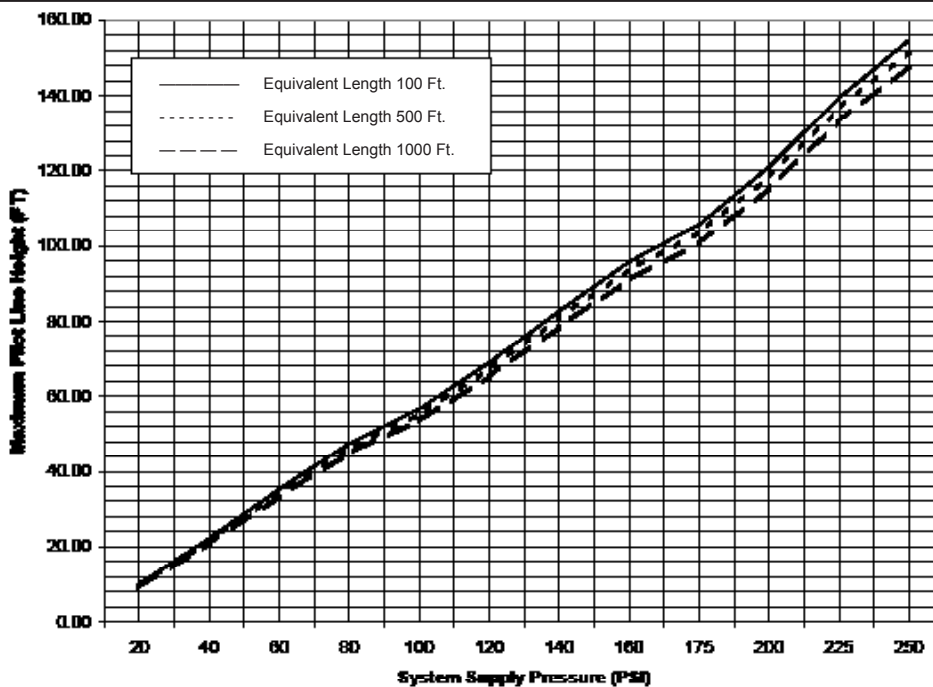

Figure 4: 4" Valves



TECHNICAL DATA

**FLOW CONTROL VALVE
MODEL J-2 HALAR® COATED
2-1/2" - 8" (DN65 - DN200)**

The Viking Corporation, 210 N Industrial Park Drive, Hastings MI 49058

Telephone: 269-945-9501 Technical Services: 877-384-5464 Fax: 269-818-1680 Email: techsvcs@vikingcorp.com

Maximum Allowable Pilot Heights for Select Equivalent Lengths of Hydraulic Release Piping

For Model J-1 Flow Control Valves with 1/8" (3.2 mm) Restricted Orifice

Graph is based on 1/2" (15 mm) pilot sprinklers installed on 1/2" (15 mm) schedule 40 galvanized release system piping.

If the maximum height of hydraulic release piping exceeds the limits shown on the graph, use Pneumatic or Electric Release System.

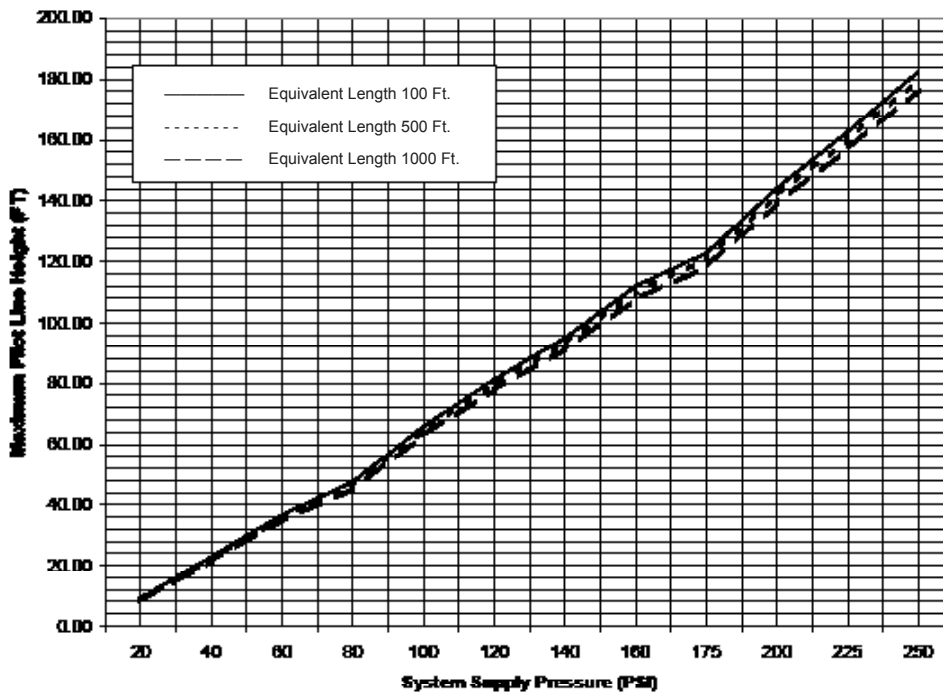

Figure 5: 6" Valves

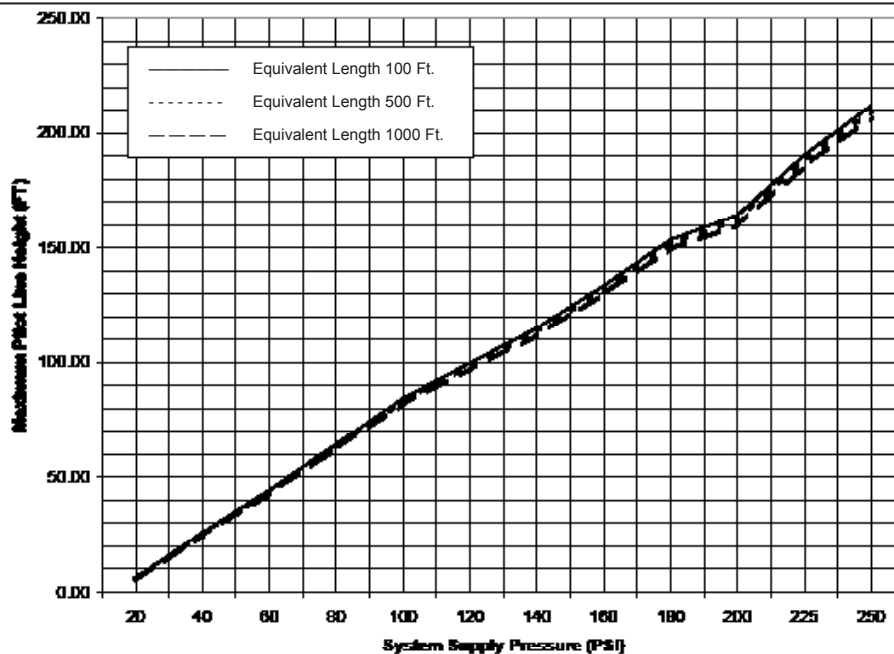

Figure 6: 8" Valves



TECHNICAL DATA

**FLOW CONTROL VALVE
MODEL J-2 HALAR® COATED
2-1/2" - 8" (DN65 - DN200)**

The Viking Corporation, 210 N Industrial Park Drive, Hastings MI 49058
 Telephone: 269-945-9501 Technical Services: 877-384-5464 Fax: 269-818-1680 Email: techsvcs@vikingcorp.com

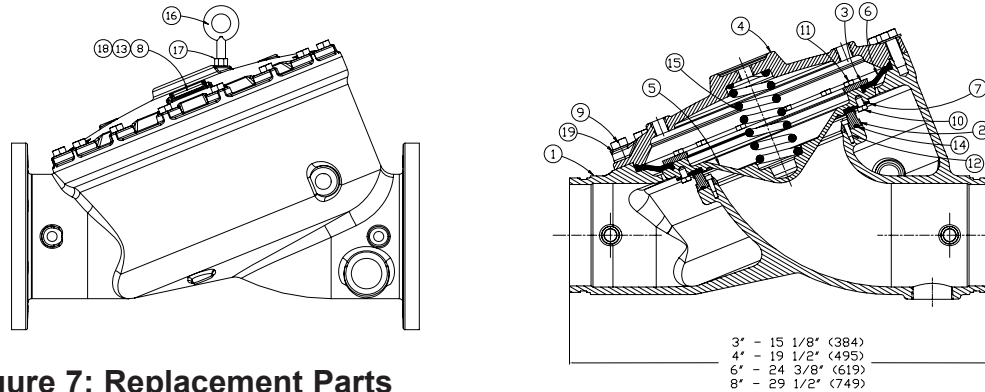

Figure 7: Replacement Parts

ITEM NO.	PART NUMBER				DESCRIPTION	MATERIAL	NO. REQ'D			
	2-1/2" (DN65) & 3" (DN80)	4" (DN100)	6" (DN150)	8" (DN200)			2-1/2" (DN65) & 3" (DN80)	4" (DN100)	6" (DN150)	8" (DN200)
1	--	--	--	--	Body	Ductile Iron, Grade 65-45-12, Halar® Coated	1	1	1	1
2	*	*	*		Seat	Brass, UNS-C84400, Nickel/Tin Plated	1	1	1	
				*	Seat	Brass, UNS-C83600, Nickel/Tin Plated				1
3	02493BN	02378BN	05704BN		Ring Clamp, Upper Diaphragm	Brass, UNS-C84400, Teflon Coated	1	1	1	
				10514N	Ring Clamp, Upper Diaphragm	Brass, UNS-C83600, Teflon Coated				1
4	--	--	--	--	Cover	Ductile Iron, Grade 65-45-12, Halar® Coated	1	1	1	1
5	08846N	08844N	08570N	10518N/B	Clapper	Ductile Iron, Teflon Coated	1	1	1	1
6	12012	11560	11561	10510	Upper Diaphragm	EPDM - ASTM D-2000	1	1	1	1
7	02497B	02382B	02176B	10512	Rubber Seat Assembly	EPDM - ASTM D-2000/ Stainless Steel UNS-S30400	1	1	1	1
8	--	--	--	--	Data Plate	Stainless Steel Etched	1	1	1	1
9	08081				Screw, H.H.C ¹ , 1/2-13 x 1 1/4 (32 mm)	Stainless Steel, UNS-S30400	10			
		08083			Screw, H.H.C ¹ , 1/2-13 x 1 1/2 (38 mm)	Stainless Steel, UNS-S30400		12		
			08085	08085	Screw, H.H.C ¹ , 5/8-11 x 1 3/4 (44 mm)	Stainless Steel, UNS-S30400			15	16
10	08215				Screw, R.H. ³ , 10-24 x 3/8 (9.5 mm)	#400 Monel	6			
		08217			Screw, H.H.C ¹ , 5/16-18 x 1/2 (13 mm)	#400 Monel		8		
			08882		Screw, H.H.C ¹ , 3/8-16 x 1/2 (13 mm)	#400 Monel			12	
				11116	Screw, S.H.C ² , 3/8-16 x 1/2 (13 mm)	#400 Monel				12
11	08214				Screw, R.H. ³ , 10-24 x 1/2 (13 mm)	#400 Monel	6			
		08217			Screw, H.H.C ¹ , 5/16-18 x 1/2 (13 mm)	#400 Monel		8		
			08218		Screw, H.H.C ¹ , 3/8-16 x 5/8 (16 mm)	#400 Monel			12	
				11117	Screw, S.H.C ² , 3/8-16 x 3/4 (19.1 mm)	#400 Monel				12
12	*				Screw, R.H. ³ , 10-24 x 5/8 (16 mm)	#400 Monel	4			
		*			Screw, S.H.C ² , 10-24 x 3/4 (19.1 mm)	#400 Monel		6		
			*	*	Screw, S.H.C ² , 1/4-20 x 3/4 (19.1 mm)	#400 Monel			8	6
13	--	--	--	--	Tack	Tack	2	4	2	4
14	*	*	*	*	O-Ring	EPDM	1	1	1	1
15	05838A	05842A	01920A	10527	Spring	Stainless Steel	1	1	1	1
16				11570	Eye Bolt, 5/8-11-UNC	Carbon Steel				1
17				F01256	Nut, 5/8-11-UNC	Stainless Steel				1
18	--	--	--	--	Plate, PN10 Flange Identifier	Aluminum	1	1	1	1
				--	Plate, PN16 Flange Identifier					
19	08413	08413	08414	08414	Washer	300 Series Stainless Steel	12	1	1	1

-- Indicates no replacement part available

* Indicates part available only in sub-assembly listed below

SUB-ASSEMBLY

3, 5, 6, 7, 9-11, 19	13489	13491	13493	13485	Clapper Assembly
2, 12, 14	14712-3	14712-4	14712-6	14712-8	Seat Replacement Kit*

¹ Hex Head Cap Screw ² Socket Head Cap Screw, (8" Valve - #10 & #11 must be S.H.C. for clearance with seat) ³ Round Head Phillips Drive Screw

*Note: Includes O-ring lubricant to be added to ring groove in seat.