



TECHNICAL DATA

PILOT PRESSURE REGULATING VALVE MODEL C-2

The Viking Corporation, 210 N Industrial Park Drive, Hastings MI 49058

Telephone: 269-945-9501 Technical Services 877-384-5464 Fax: 269-818-1680 Email: techsvcs@vikingcorp.com

1. DESCRIPTION

The Viking Model C-2 Pilot Pressure Regulating Valve is a direct-acting, single-seated, spring-loaded diaphragm valve. When installed as a pilot regulating valve on a Viking Model H or J Flow Control Valve, it automatically reduces higher inlet pressure to a lower delivery pressure, maintaining that pressure within a close limit regardless of fluctuations in the higher pressure inlet line.

The Model H or J Flow Control Valve, equipped with the Model C-2 Pilot Pressure Regulating Valve, is recommended for systems where a reduction of pressure surges or water hammer is desired or where it is desired to maintain a predetermined discharge pressure. This arrangement, with additional ILBP assemblies, can also be used on a bladder tank foam system to provide the pressure differential necessary for proper proportioning. The Viking Model C-2 Pilot Pressure Regulating Valve is also a required component of the Viking Model A and B Pilot Operated Pressure Regulating Valve (refer to Viking technical data for the Pilot Operated Pressure Regulating Valve).

Viking Model C-2 Pilot Pressure Regulating Valve is to be installed in accordance with the applicable NFPA Installation Standards and the Authorities Having Jurisdiction.

Features

1. Three ranges of regulation available.
2. Allows control of system discharge pressure.
3. Allows proper proportioning on foam systems, even at low flows.
4. Accessories
 - a. Modular trim kit for installation on Viking Flow Control Valves equipped with Conventional Trim.



2. LISTINGS AND APPROVALS

See Tables 1 and 2

3. TECHNICAL DATA

Specifications:

Inlet Pressure Rating: to 250 PSIG (17.2 bar) at temperatures below 200 °F (93 °C)

Outlet Pressure: Three spring options (three ranges of regulation) from 25 PSIG (1.7 bar) to 150 PSIG (10.3 bar) (See Tables 1 and 2)

Connections: ½" NPT internal thread connections

Shipping weight: Approx. 8 lbs. (3,63 kg)

Material Specifications:

Refer to Figure 11

Ordering Information:

Order Viking Part Number 10799 - Includes Model C-2 Pilot Pressure Regulating Valve, Part Number 10791, with spring kit Part Number 09200 installed, and spring kit Part Numbers 09198 and 09199 (loose).

Viking Technical Data may be found on
The Viking Corporation's Web site at
<http://www.vikinggroupinc.com>.
The Web site may include a more recent
edition of this Technical Data Page.

4. INSTALLATION

A. General Installation Instructions:

The Viking Flow Control Valve, Pilot Pressure Regulating Valve, and associated trim must be installed in an area not subject to freezing temperatures or physical damage. When corrosive atmospheres and/or contaminated water supplies are present, it is the owner's responsibility to verify compatibility with the Pilot Pressure Regulating Valve and associated equipment.

For deluge systems, to allow the flow required for adjustment of the Pilot Pressure Regulating Valve, consider installing a system isolation valve and test valve with discharge pipe, downstream from the outlet of the Flow Control Valve. See step 5 of paragraph 4.B PLACING SYSTEM IN SERVICE.

Inlet/Outlet Pressures:

When the Pilot Pressure Regulating Valve is used in conjunction with the Viking Model H or J Flow Control Valve, the difference between the water supply pressure and the desired outlet (downstream) pressure should be greater than 20 PSI (1.4 bar) to maintain control of discharge pressure. Refer to Figure 1 for proper operating range of pressure reduction and flow. Locate inlet and outlet pressure on cavitation chart. If the point located falls in the shaded area, cavitation may occur. To accomplish large pressure reductions and avoid cavitation, two Flow Control Valves, arranged in series, should be used to accomplish the reduction in stages.

For supply pressures above 175 PSI, the heavy spring (P/N 09200) must be used.

CAUTION: DUE TO THE FLOW REGULATING CHARACTERISTIC OF THIS DEVICE, ITS IMPACT ON SYSTEM HYDRAULICS SHOULD BE CAREFULLY CONSIDERED, ESPECIALLY WHEN RETROFITTED ONTO EXISTING SYSTEMS.



TECHNICAL DATA

PILOT PRESSURE REGULATING VALVE MODEL C-2

The Viking Corporation, 210 N Industrial Park Drive, Hastings MI 49058

Telephone: 269-945-9501 Technical Services 877-384-5464 Fax: 269-818-1680 Email: techsvcs@vikingcorp.com

Regulating Spring Options:

The Pilot Pressure Regulating Valve is factory assembled and shipped with a regulating spring for use where the desired discharge pressure is 80 to 150 PSI (5.5 bar to 10.3 bar). If the desired discharge pressure is below that range, the factory-installed spring must be removed and the appropriate regulating spring installed. See Figures 2 and 3 for regulating spring pressure range options, part numbers, and identification. To replace the factory installed regulating spring, refer to paragraph 6.B Regulating Spring Replacement.

Sensing Line Connection:

To ensure downstream pressure control and minimize fluctuations due to flow turbulence, it is recommended that the sensing line connection to downstream piping be installed at least five pipe diameters from the Flow Control Valve or any fitting. If necessary, the sensing line may be connected to the 1/2" (15 mm) NPT port provided on the discharge connection of Flow Control Valve, which is provided with the trim piping supplied with valve. However, downstream pressure fluctuations due to flow turbulence may occur.

NEVER locate the sensing line connection to the bowl area of the valve. When connected in this manner, erratic operation may occur due to cavitation of Pilot Valve.

Trim:

All water from the priming chamber of the Flow Control Valve must pass through the Pilot Pressure Regulating Valve for regulation to occur. For this reason, when using the Pilot Valve for pressure regulation of preaction or deluge systems, use electric or pneumatic release systems only. For wet systems, refer to Technical Data describing the Viking Pilot Operated Pressure Control Valve, which is factory assembled and pre-trimmed complete with the Pilot Pressure Regulating Valve.

The Pilot Pressure Regulating Valve may be installed in any position. The inlet, outlet, and direction of flow are clearly identified on the body casting.

For proper operation and approval, the Pilot Pressure Regulating Valve must be installed according to the current Viking Flow Control Valve Trim Chart and Viking schematic drawings for the Pressure Regulating system being installed. These trim charts and schematic drawings are provided in the Pilot Pressure Regulating Valve Package and in the appropriate design section of the Viking Engineering Design Data book.

1. Verify that the Viking Flow Control Valve used is trimmed according to current trim charts (complete with speed control assembly) designed for use with the Viking Pilot Pressure Regulating Valve.
2. Remove plastic thread protectors from the openings of the Pilot Pressure Regulating Valve.
3. Apply a small amount of pipe-joint compound or tape to the external threads of all pipe connections required. Take care not to allow any compound, tape, or other foreign matter inside any of the nipples or openings of the Pilot Pressure Regulating Valve or trim components.
4. Install the Pilot Pressure Regulating Valve and trim piping according to the current Viking Trim Chart provided.

Hydrostatic Test:

CAUTION: WHEN A PRESSURE OPERATED RELIEF VALVE (PORV) IS INSTALLED IN THE FLOW CONTROL VALVE TRIM, DO NOT SUBJECT THE PORV TO A 250 PSI (17.2 BAR) HYDROSTATIC SYSTEM TEST UNLESS THE 1/2" TRIM PIPING CONNECTS THE OUTLET CHAMBER OF THE FLOW CONTROL VALVE TO THE OPERATING (SINGLE-PORTED) END OF THE PORV IS DISCONNECTED AND PLUGGED DURING THE TEST. REMOVE THE PLUGS AND RE-CONNECT THE PIPING BEFORE PLACING THE SYSTEM IN SERVICE.

5. For wet pipe (closed) sprinkler systems, a 1/2" relief valve* is installed downstream of the pilot operated pressure control valve. The pressure relief valve shall be set 10 PSIG higher than Pilot Pressure Regulating Valve. * Larger pressure relief valve may be required. Consult Installation Standards and the Authority Having Jurisdiction

B. PLACING THE SYSTEM IN SERVICE

1. Verify that the Pilot Pressure Regulating Valve is equipped with the regulating spring appropriate for the desired inlet pressure downstream pressure.
2. Place the Viking Flow Control Valve in service according to instructions printed in current Viking Flow Control Valve Technical Data.
3. Adjust Speed Control actuation according to instructions printed in current Technical Data describing the Viking Speed Control Assembly.

CAUTION: ANY AIR IN THE WATER SUPPLY OR AIR TRAPPED IN THE PRIMING CHAMBER OF THE FLOW CONTROL VALVE MAY RESULT IN SEVERE WATER HAMMER AND CYCLING, WHICH CAN CAUSE DAMAGE TO THE VALVE, CONNECTED PIPING AND ASSOCIATED EQUIPMENT.

4. To ensure smooth regulation, all air must be removed from the priming chamber of the Flow Control Valve.
 - a. Temporarily remove the 1/4" plug from the three-way globe valve at the highest water gauge connection in the Flow Control Valve trim or open the bleed-off valve if provided.



TECHNICAL DATA

PILOT PRESSURE REGULATING VALVE MODEL C-2

The Viking Corporation, 210 N Industrial Park Drive, Hastings MI 49058

Telephone: 269-945-9501 Technical Services 877-384-5464 Fax: 269-818-1680 Email: techsvcs@vikingcorp.com

- b. Open the three-way globe valve (water will flow from the opening).
- c. When all air has been removed, close the three-way globe valve and replace the 1/4" plug.

Downstream Pressure Adjustment:

It is recommended that the desired discharge pressure of the system be adjusted with a minimum flow of 25 GPM (95 LPM) or greater flowing through the Flow Control Valve.

For preaction systems and Pressure Regulated Wet Systems, the system main drain valve, located downstream from the clapper of the check valve on the system riser, can be used for this purpose.

For deluge systems, where flow through open sprinklers and/or nozzles is not practical, a test valve with discharge pipe must be provided in the riser between the Flow Control Valve and an isolation valve.

5. For preaction systems and Pressure Regulated Wet Systems, (closed sprinklers), OPEN the main drain located downstream from the check valve in the system riser. For deluge systems and where provided, CLOSE the system isolation valve and OPEN the system test valve
6. Operate the system to open the Flow Control Valve. Establish a minimum flow of 25 GPM (95 LPM) or greater and observe the downstream pressure gauge.
7. If adjustment of the Pilot Pressure Regulating Valve is necessary, use the appropriate wrench to: (Refer to Figure 13)
 - a. Loosen locknut (2).
 - b. Turn adjusting screw (1) clockwise to increase pressure or counter clockwise to decrease pressure.

WARNING: ADJUSTMENT SCREW MUST ENGAGE SPRING TO ENSURE PROPER OPERATION.

- c. After setting to desired pressure, tighten locknut (2) on adjusting screw to secure setting.
8. Proceed as indicated for the system used:
 - a. For Pressure Regulated Wet systems, CLOSE the main drain installed in the Alarm Check Valve.
 - b. For preaction systems (closed sprinklers), CLOSE the Main Water Supply Control Valve. After the sprinkler piping has properly drained, CLOSE the main drain located downstream from the check valve in the system riser.
 - c. For deluge systems (and where provided), CLOSE the Main Water Supply Control Valve. OPEN the system isolation valve and CLOSE the system test valve.

NOTE: THE PRESSURE GAUGE INSTALLED ON OUTLET PIPING FROM THE PILOT PRESSURE REGULATING VALVE MAY INDICATE STATIC PRESSURE APPROXIMATELY 8 TO 10 PSIG HIGHER THAN THE OUTLET "SET" PRESSURE DETERMINED ABOVE. THIS IS DUE TO CHANGES IN FLOW VELOCITY THAT MAY OCCUR WHEN FLOW THROUGH THE SYSTEM IS STOPPED. ZERO FLOW CONDITION MAY RESULT IN A MOMENTARY OUTLET PRESSURE OF 50 PSI MORE THAN THE SET PRESSURE. ACTUAL "SET" PRESSURE SHOULD NOT BE AFFECTED.

9. Record "set" pressure in the space provided on the Regulating Spring Identification Tag provided.
10. Place the system in service according to instructions printed in current Technical Data describing the Viking Flow Control Valve, the release system used, and instructions for the system used.

5. OPERATION

(Refer to Figure 11)

For pressure regulation, the Model C-2 Pilot Pressure Regulating Valve is installed in the hydraulic release trim piping of the Viking Model H or J Flow Control Valve equipped with either an electric or pneumatic release system. Flow through the Pilot Pressure Regulating Valve is controlled by regulating spring (6), which is field adjustable to the desired downstream pressure to be maintained.

When the Flow Control Valve operates, water released from its priming chamber enters the inlet of the Pilot Pressure Regulating Valve. A sensing line connects the system piping, downstream of Flow Control Valve, to the outlet chamber of the Pilot Pressure Regulating Valve. Downstream system pressure, on the control chamber side of diaphragm (9), is applied against regulating spring (6). When downstream pressure rises above the set point of spring (6), flow through the Pilot Pressure Regulating Valve is stopped. When downstream pressure falls below the set point of spring (6), flow through the valve resumes. The regulated flow through the Pilot Pressure Regulating Valve controls the pressure in the priming chamber of the Model H or J Flow Control Valve to open or close the Flow Control Valve clapper as required to regulate downstream system pressure.

Should the inlet pressure fall below the outlet set pressure, the pilot valve will open fully and relieve all pressure from the priming chamber of the control valve. For more specific design information regarding flow rates and available outlet pressure, refer to the control valve technical data page for the friction loss of the control valve and the Hazen-William's formula.

NOTE: FOR A REFERENCE OF THE FLOW RATES AND OUTLET PRESSURES AVAILABLE WHEN THE INLET PRESSURE DROPS BELOW THE OUTLET SET PRESSURE, SEE FIGURES 2 - 10.



TECHNICAL DATA

PILOT PRESSURE REGULATING VALVE MODEL C-2

The Viking Corporation, 210 N Industrial Park Drive, Hastings MI 49058

Telephone: 269-945-9501 Technical Services 877-384-5464 Fax: 269-818-1680 Email: techsvcs@vikingcorp.com

**Table 1 - Discharge Pressure and Flow Ranges When Using
the Viking Model J Straight Through Flow Control Valve**

PILOT VALVE SPRING KIT PART NO.	SPRING IDENTIFICATION			MAX. INLET PRESSURE PSI (bar) ^{4&5}	DISCHARGE PRESSURE RANGE PSI (bar)	VALVE SIZE	FLOW RANGE GPM (LPM) ⁶	VALVE CV 1 PSI ΔP WIDE OPEN ⁷	FRICTION LOSS ⁸ FT. (M)	APPROVALS
	WIRE DIAMETER IN. (MM)	OUTSIDE DIAMETER IN. (MM)	COLOR							
09198 ¹	.207 (5,3)	1.275 (32,4)	Blue	175 (12.1)	25 - 50 (1.7 - 3.5)	1-1/2" (DN40)	25 - 125 (95 - 473)	66 GPM (250 LPM)	7 ft. (2,1 m)	FM
						2" (DN50)	25 - 225 (95 - 852)	93 GPM (352 LPM)	13 ft. (3,9 m)	FM
						2-1/2" ³ (DN60)	100 - 300 (95 - 1 136)	155 GPM (587 LPM)	12 ft. (3,6 m)	--
						3" ³ (DN75)	100 - 450 (379 - 1 703)	201 GPM (760 LPM)	22 ft. (6,7 m)	--
						4" (DN100)	25 - 500 (95 - 1 893)	428 GPM (1 620 LPM)	21 ft. (6,4 m)	FM
						6" (DN150)	25 - 2500 (95 - 9 464)	839 GPM (3 176 LPM)	39 ft. (11,9 m)	FM
						8" (DN200)	25 - 4000 (95 - 15 142)	1577 GPM (5970 LPM)	57 ft. (17,4 m)	FM
09199	.250 (6,4)	1.375 (34,9)	Green	175 (12.1)	50 - 125 (3.4 - 8.6)	1-1/2" (DN40)	25 - 180 (95 - 681)	66 GPM (250 LPM)	7 ft. (2,1 m)	FM
						2" (DN50)	25 - 300 (95 - 1 136)	93 GPM (352 LPM)	13 ft. (3,9 m)	FM
						2-1/2" ³ (DN60)	100 - 450 (95 - 1 703)	155 GPM (587 LPM)	12 ft. (3,6 m)	--
						3" ³ (DN75)	100 - 700 (379 - 2 650)	201 GPM (760 LPM)	22 ft. (6,7 m)	--
						4" (DN100)	25 - 800 (95 - 3 028)	428 GPM (1 620 LPM)	21 ft. (6,4 m)	FM
						6" (DN150)	25 - 2500 (95 - 9 464)	839 GPM (3 176 LPM)	39 ft. (11,9 m)	FM
						8" (DN200)	25 - 4400 (95 - 16 656)	1577 GPM (5970 LPM)	57 ft. (17,4 m)	FM
09200 ²	.286 (7,3)	1.45 (36,8)	Not Painted	250 (17.2)	80 - 150 (5.5 - 10.3)	1-1/2" (DN40)	25 - 200 (95 - 757)	66 GPM (250 LPM)	7 ft. (2,1 m)	FM
						2" (DN50)	25 - 325 (95 - 852)	93 GPM (352 LPM)	13 ft. (3,9 m)	FM
						2-1/2" ³ (DN60)	100 - 550 (95 - 2 082)	155 GPM (587 LPM)	12 ft. (3,6 m)	--
						3" ³ (DN75)	100 - 900 (379 - 3 407)	201 GPM (760 LPM)	22 ft. (6,7 m)	--
						4" (DN100)	25 - 1250 (95 - 4 732)	428 GPM (1 620 LPM)	21 ft. (6,4 m)	FM
						6" (DN150)	25 - 2500 (95 - 9 464)	839 GPM (3 176 LPM)	39 ft. (11,9 m)	FM
						8" (DN200)	25 - 4400 (95 - 16 656)	1577 GPM (5970 LPM)	57 ft. (17,4 m)	FM

¹ For operation with the Pilot Valve Spring Number 09198, the maximum inlet pressure is between 100 PSI and 175 PSI. The maximum inlet pressure can be determined by the following formula: Max. PSI Inlet Pressure = 3 x outlet pressure (PSI) + 25

² Spring Kit Part Number 09200 is shipped installed in Model C-2 Pilot Pressure Regulating Valve

³ 2-1/2" & 3" Models are for open head deluge systems only. Downstream pressure setting must be set to flow 100 GPM minimum. Not listed or approved.

⁴ The Inlet and Outlet Pressure Differential should be greater than 20 PSI (1.4 bar) for 1-1/2", 2", 3" and 4" valves, between 20 PSI and 60 PSI (1.4 and 4.1 bar) for 6" valves and between 20 PSI and 70 PSI (1.4 and 4.8 bar) to maintain accurate control of outlet pressure.

⁵ Minimum recommended inlet pressure is 50 PSI (3.4 bar)

⁶ Maximum flow in worst condition (maximum pressure differential) of each spring of Model C-2 Pilot Pressure Regulating Valve that will regulate discharge pressure within 10% of set pressure flowing at minimum of 25 GPM (95 LPM)

⁷ CV is the flow rate through valve that produces 1 PSIG pressure differential, with the valve in the wide open position.

⁸ Friction Loss shown is expressed in equivalent length of Schedule 40 pipe based on Hazen & Williams formula C = 120, with valve in the wide open position.

	<h1 style="margin:0;">TECHNICAL DATA</h1>	<h2 style="margin:0;">PILOT PRESSURE REGULATING VALVE</h2> <h3 style="margin:0;">MODEL C-2</h3>
---	---	---

The Viking Corporation, 210 N Industrial Park Drive, Hastings MI 49058
 Telephone: 269-945-9501 Technical Services 877-384-5464 Fax: 269-818-1680 Email: techsvcs@vikingcorp.com

Table 2 - Discharge Pressure and Flow Ranges When Using the Viking Model H Angle Style Flow Control Valve

PILOT VALVE SPRING KIT PART NO.	SPRING IDENTIFICATION			MAX. INLET PRESSURE PSI (bar) ^{4&5}	DISCHARGE PRESSURE RANGE PSI (bar)	VALVE SIZE	FLOW RANGE GPM (LPM) ⁶	VALVE CV 1 PSI ΔP WIDE OPEN ⁷	FRICTION LOSS ⁸ FT. (M)	APPROVALS
	WIRE DIAMETER IN. (MM)	OUTSIDE DIAMETER IN. (MM)	COLOR							
09198 ¹	.207 (5,3)	1.275 (32,4)	Blue	175 (12.1)	25 - 50 (1.7 - 3.5)	2" (DN50)	25 - 225 (95 - 852)	93 GPM (352 LPM)	13 ft. (3,9 m)	UL
						3" ³ (DN75)	100 - 450 (379 - 1 703)	201 GPM (760 LPM)	22 ft. (6,7 m)	--
						4" (DN100)	25 - 500 (95 - 1 893)	428 GPM (1 620 LPM)	21 ft. (6,4 m)	UL
						6" (DN150)	25 - 2500 (95 - 9 464)	839 GPM (3 176 LPM)	39 ft. (11,9 m)	UL
09199	.250 (6,4)	1.375 (34,9)	Green	175 (12.1)	50 - 125 (3.4 - 8.6)	2" (DN50)	25 - 300 (95 - 1 136)	93 GPM (352 LPM)	13 ft. (3,9 m)	UL
						3" ³ (DN75)	100 - 700 (379 - 2 650)	201 GPM (760 LPM)	22 ft. (6,7 m)	--
						4" (DN100)	25 - 800 (95 - 3 028)	428 GPM (1 620 LPM)	21 ft. (6,4 m)	UL
						6" (DN150)	25 - 2500 (95 - 9 464)	839 GPM (3 176 LPM)	39 ft. (11,9 m)	UL
09200 ²	.286 (7,3)	1.45 (36,8)	Not Painted	250 (17.2)	80 - 150 (5.5 - 10.3)	2" (DN50)	25 - 325 (95 - 852)	93 GPM (352 LPM)	13 ft. (3,9 m)	UL
						3" ³ (DN75)	100 - 900 (379 - 3 407)	201 GPM (760 LPM)	22 ft. (6,7 m)	--
						4" (DN100)	25 - 1250 (95 - 4 732)	428 GPM (1 620 LPM)	21 ft. (6,4 m)	UL
						6" (DN150)	25 - 2500 (95 - 9 464)	839 GPM (3 176 LPM)	39 ft. (11,9 m)	UL

¹ For operation with the Pilot Valve Spring Number 09198, the maximum inlet pressure is between 100 PSI and 175 PSI. The maximum inlet pressure can be determined by the following formula: Max. PSI Inlet Pressure = 3 x outlet pressure (PSI) + 25

² Spring Kit Part Number 09200 is shipped installed in Model C-2 Pilot Pressure Regulating Valve

³ 3" Models are for open head deluge systems only. Downstream pressure setting must be set to flow 100 GPM minimum. Not listed or approved.

⁴ The Inlet and Outlet Pressure Differential should be greater than 20 PSI (1.4 bar) for 2", 3" and 4" valves and between 20 PSI and 60 PSI (1.4 and 4.1 bar) for 6" valves to maintain accurate control of outlet pressure.

⁵ Minimum recommended inlet pressure is 50 PSI (3.4 bar)

⁶ Maximum flow in worst condition (maximum pressure differential) of each spring of Model C-2 Pilot Pressure Regulating Valve that will regulate discharge pressure within 10% of set pressure flowing at minimum of 25 GPM (95 LPM)

⁷ CV is the flow rate through valve that produces 1 PSIG pressure differential, with the valve in the wide open position.

⁸ Friction Loss shown is expressed in equivalent length of Schedule 40 pipe based on Hazen & Williams formula C = 120, with valve in the wide open position.

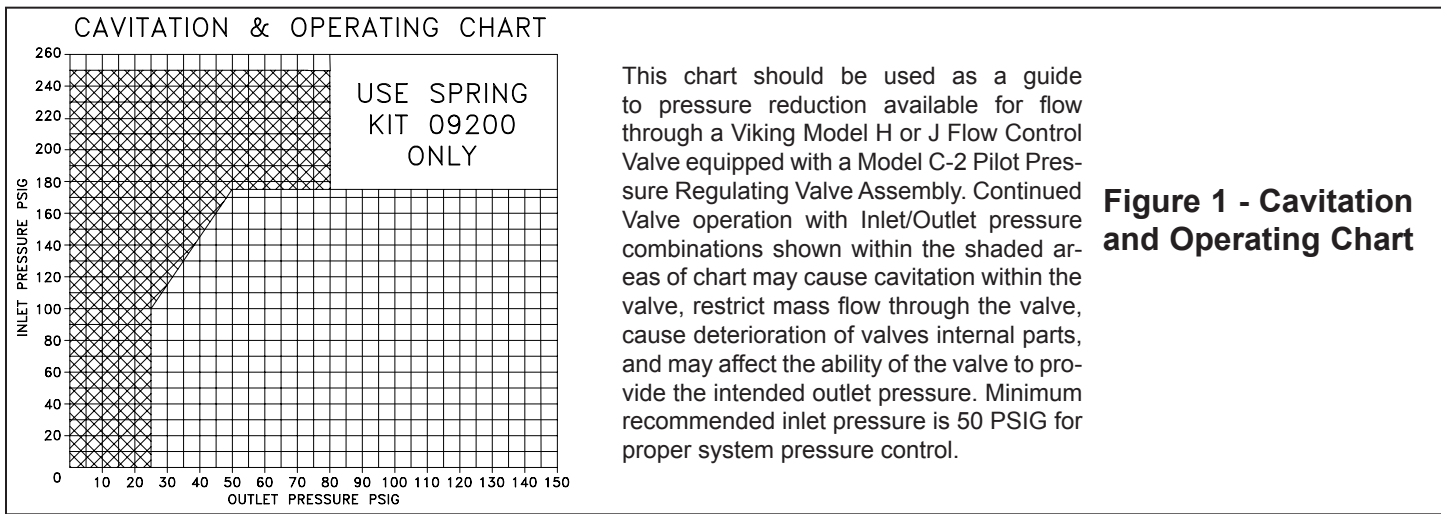



TECHNICAL DATA

PILOT PRESSURE REGULATING VALVE MODEL C-2

The Viking Corporation, 210 N Industrial Park Drive, Hastings MI 49058

Telephone: 269-945-9501 Technical Services 877-384-5464 Fax: 269-818-1680 Email: techsvcs@vikingcorp.com

6. INSPECTIONS, TESTS AND MAINTENANCE

NOTICE: THE OWNER IS RESPONSIBLE FOR MAINTAINING THE FIRE PROTECTION SYSTEM AND DEVICES IN PROPER OPERATING CONDITION. THE PILOT PRESSURE REGULATING VALVE MUST BE KEPT FROM FREEZING CONDITIONS AND PHYSICAL DAMAGE THAT COULD IMPAIR ITS OPERATION.

WARNING: ANY SYSTEM MAINTENANCE THAT INVOLVES PLACING A CONTROL VALVE OR DETECTION SYSTEM OUT OF SERVICE MAY ELIMINATE THE FIRE PROTECTION CAPABILITIES OF THAT SYSTEM. PRIOR TO PROCEEDING, NOTIFY ALL AUTHORITIES HAVING JURISDICTION. CONSIDERATION SHOULD BE GIVEN TO EMPLOYMENT OF A FIRE PATROL IN THE AFFECTED AREAS.

A. Inspection

It is imperative that the system be inspected and tested on a regular basis. The frequency of inspections may vary due to contaminated water supplies, corrosive water supplies or corrosive atmospheres. Also, the alarm devices, detection systems, or other connected trim may require a more frequent inspection schedule. For minimum maintenance and inspection requirements, refer to NFPA 25. In addition, the Authority Having Jurisdiction may have additional maintenance, testing, and inspection requirements that must be followed. The following recommendations are minimum requirements.

After Each Operation

1. Sprinkler systems that have been subjected to a fire must be returned to service as soon as possible. The entire system must be inspected for damage, and repaired or replaced as necessary.
2. Pilot Pressure Regulating Valves and trim that have been subjected to brackish water, salt water, foam, foam/water solution, or any other corrosive water supply, should be flushed with good quality fresh water before being returned to service. Inspect and clean all strainers (see ANNUAL maintenance).
3. Perform ANNUAL maintenance after every operation.

B. Maintenance

Annual Maintenance (See Figure 11)

It is recommended to perform annual maintenance and verify proper operation of the Pressure Regulating Pilot Valve during annual testing of the Flow Control Valve. Refer to instructions in Flow Control Valve Technical Data.

1. Remove the system from service. (Refer to instructions printed in current Technical Data for the Viking Flow Control Valve and release system used.)
2. Use the appropriate wrench to loosen (turn counterclockwise) and remove Brass (2-1/8" hex) Plug Assembly (17) with Gasket (15), Strainer Screen (13), and Piston Spring (16).

CAUTION: THE ASSEMBLY IS UNDER SLIGHT SPRING PRESSURE FROM PISTON SPRING (16).

3. Clean and inspect the Strainer Screen (13).
4. Reverse disassembly step 2 above to re-assemble the unit.
5. Verify proper operation of the Pilot Pressure Regulating Valve. Perform steps 2 and 4 through 10 of paragraph 4.B PLACING THE SYSTEM IN SERVICE.

Regulating Spring Replacement (Refer to Figure 11)

To replace spring:

1. Remove the system from service. (Refer to instructions printed in current Technical Data for the Viking Flow Control Valve, and release system used.)
2. Use the appropriate wrench to:
 - a. Loosen locking hex nut (2) (11/16" wrench required).
 - b. Turn adjusting screw (1) counterclockwise to remove tension from Pressure Spring (6).
 - c. Remove six cover bolts and nuts (9/16" open-end wrench required).
3. Remove Spring Chamber Cover (5), Spring Button (4), and Pressure Spring (6).
4. Install desired Pressure Spring (6). (Refer to Table 1 for regulating Pressure Spring pressure range options, part numbers, and identification.) Position the spring on the boss provided on top surface of Pressure Plate (8) .
5. Re-install Spring Button (4). Position the bossed surface against Spring (6) and the concave screw locating surface away from Spring (6).
6. Re-install Spring Chamber Cover (5) and six cover bolts and nuts. With a 1/2" wrench, cross-tighten hex-head bolts for even compression.
7. Turn adjusting screw clockwise compressing spring approximately 1/4" (6,4 mm).
8. Adjust valve to desired discharge pressure. Perform steps 1 through 10 of paragraph 5.B PLACING THE SYSTEM IN

	<h1 style="margin: 0;">TECHNICAL DATA</h1>	<h2 style="margin: 0;">PILOT PRESSURE REGULATING VALVE</h2> <h3 style="margin: 0;">MODEL C-2</h3>
---	--	---

The Viking Corporation, 210 N Industrial Park Drive, Hastings MI 49058

Telephone: 269-945-9501 Technical Services 877-384-5464 Fax: 269-818-1680 Email: techsvcs@vikingcorp.com
SERVICE.

7. AVAILABILITY

The Viking Pilot Pressure Regulating Valve is available through a network of domestic and international distributors. See the Viking Corp. Web site for closest distributor or contact The Viking Corporation.

8. GUARANTEES

For details of warranty, refer to Viking's current list price schedule or contact Viking directly.

**FIGURE 2 -
2" MODEL A-2 PRESSURE REGULATING VALVE WITH SPRING 09198
POSSIBLE FLOW RATE WHEN THE INLET PRESSURE FALLS BELOW THE OUTLET SET PRESSURE**

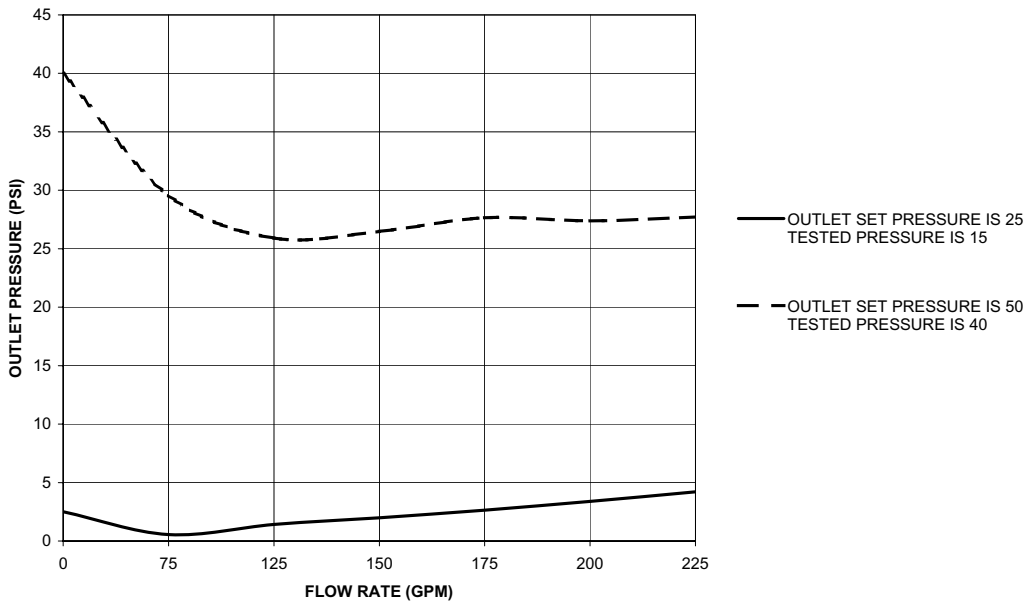

NOTE: This graph is a requirement of UL and should be used as reference only.



TECHNICAL DATA

PILOT PRESSURE REGULATING VALVE MODEL C-2

The Viking Corporation, 210 N Industrial Park Drive, Hastings MI 49058

Telephone: 269-945-9501 Technical Services 877-384-5464 Fax: 269-818-1680 Email: techsvcs@vikingcorp.com

**FIGURE 3 -
2" MODEL A-2 PRESSURE REGULATING VALVE WITH SPRING 09199
POSSIBLE FLOW RATE WHEN THE INLET PRESSURE FALLS BELOW THE OUTLET SET PRESSURE**

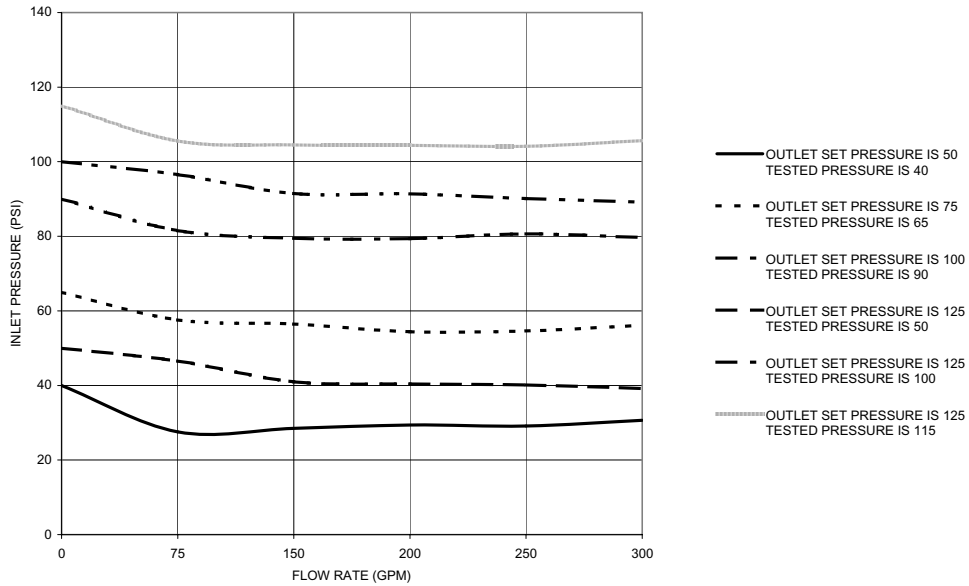

NOTE: This graph is a requirement of UL and should be used for reference only.

**FIGURE 4 -
2" MODEL A-2 PRESSURE REGULATING VALVE WITH SPRING 09200
POSSIBLE FLOW RATE WHEN THE INLET PRESSURE FALLS BELOW THE OUTLET SET PRESSURE**

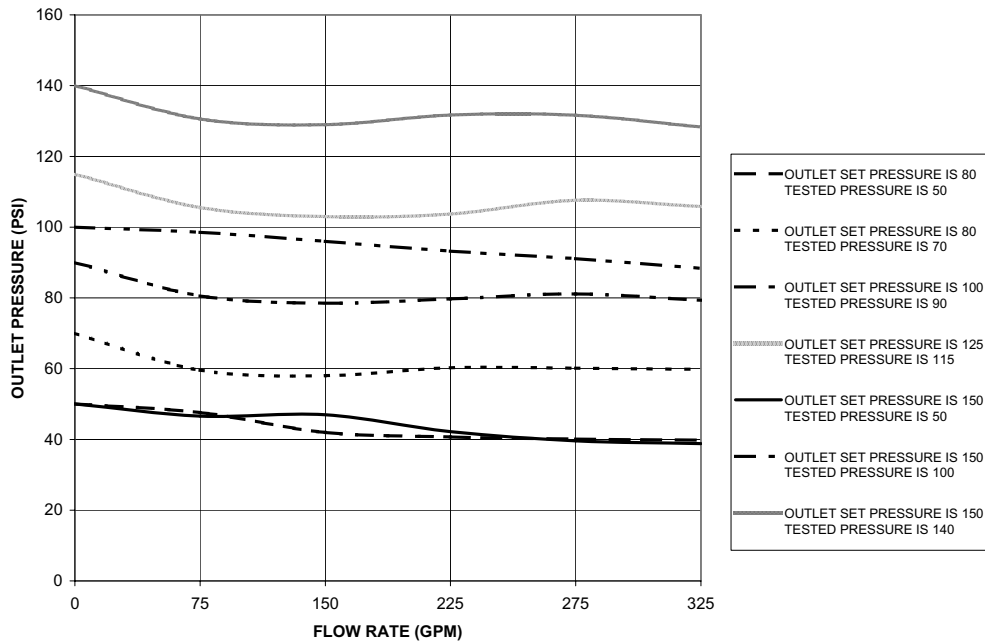

NOTE: This graph is a requirement of UL and should be used as reference only.



TECHNICAL DATA

PILOT PRESSURE REGULATING VALVE MODEL C-2

The Viking Corporation, 210 N Industrial Park Drive, Hastings MI 49058

Telephone: 269-945-9501 Technical Services 877-384-5464 Fax: 269-818-1680 Email: techsvcs@vikingcorp.com

FIGURE 5 -
4" MODEL A-2 PRESSURE REGULATING VALVE WITH SPRING 09198
POSSIBLE FLOW RATE WHEN THE INLET PRESSURE FALLS BELOW THE OUTLET SET PRESSURE

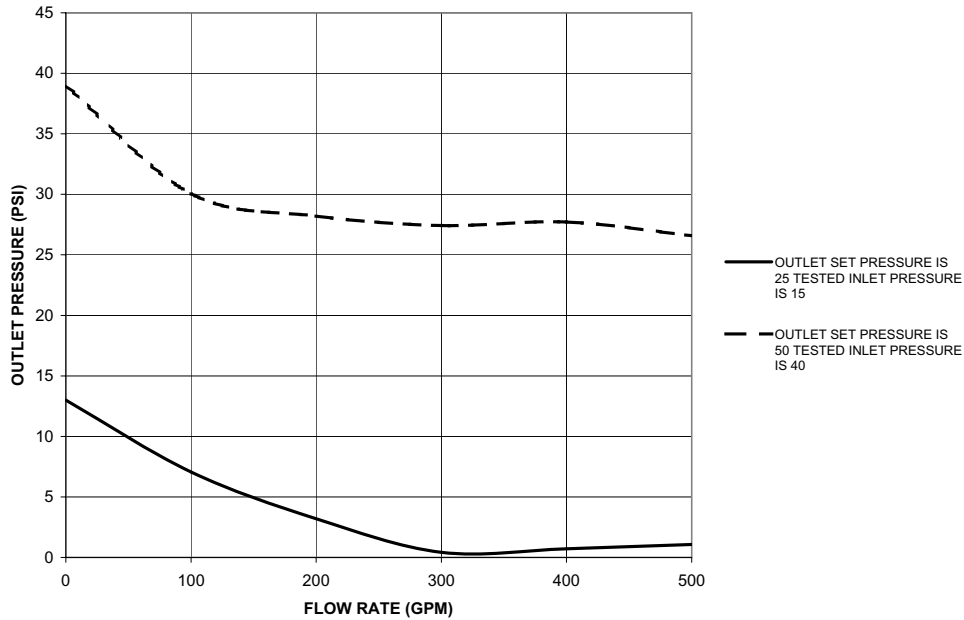

NOTE: This graph is a requirement of UL and should be used as reference only.

FIGURE 6 -
4" MODEL A-2 PRESSURE REGULATING VALVE WITH SPRING 09199
POSSIBLE FLOW RATE WHEN THE INLET PRESSURE FALLS BELOW THE OUTLET SET PRESSURE

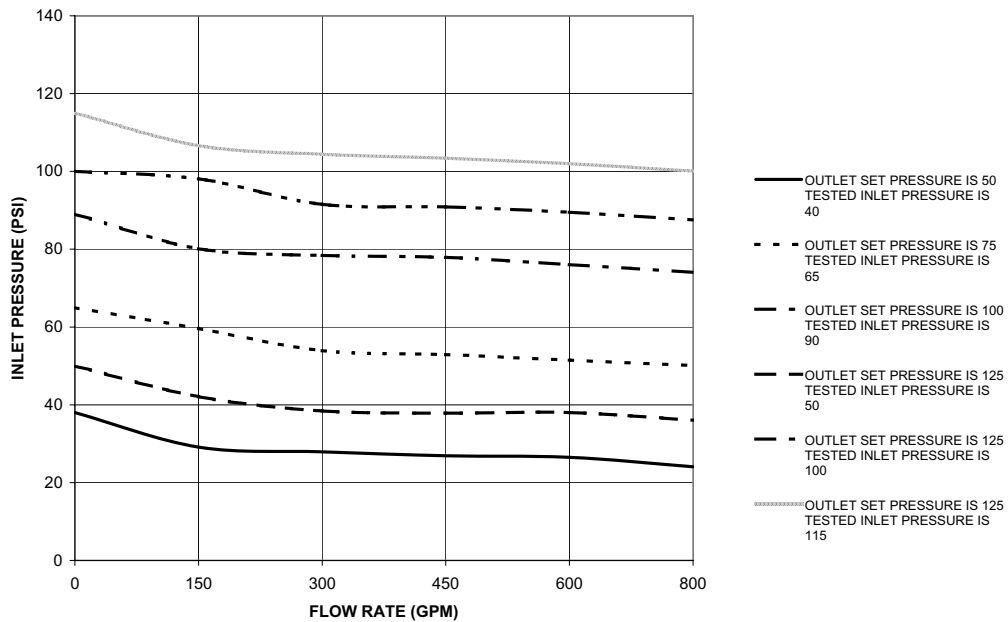

NOTE: This graph is a requirement of UL and should be used as reference only.



TECHNICAL DATA

PILOT PRESSURE REGULATING VALVE MODEL C-2

The Viking Corporation, 210 N Industrial Park Drive, Hastings MI 49058

Telephone: 269-945-9501 Technical Services 877-384-5464 Fax: 269-818-1680 Email: techsvcs@vikingcorp.com

FIGURE 7 -
4" MODEL A-2 PRESSURE REGULATING VALVE WITH SPRING 09200
POSSIBLE FLOW RATE WHEN THE INLET PRESSURE FALLS BELOW THE OUTLET SET PRESSURE

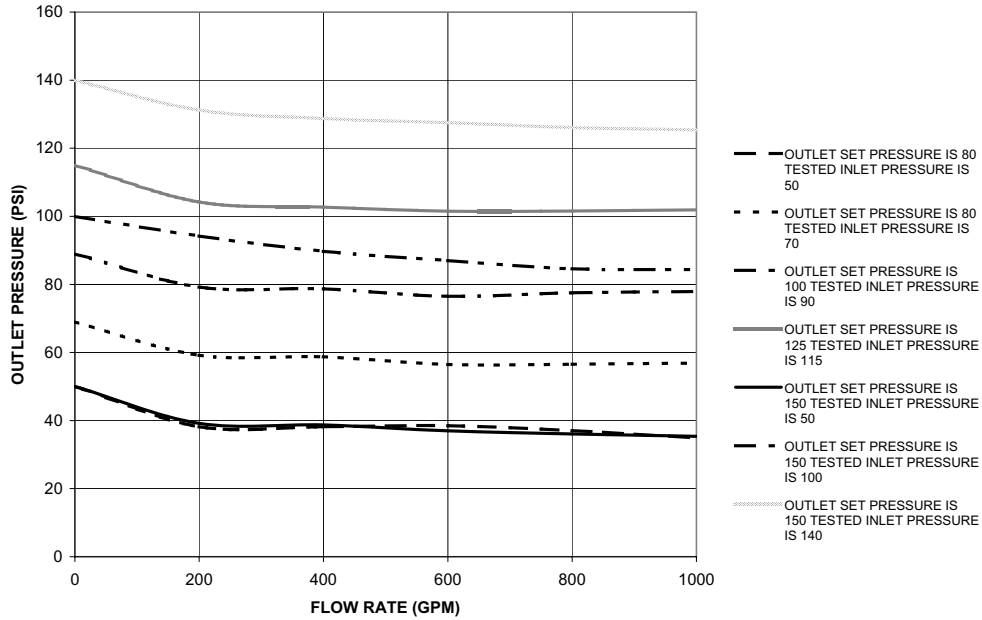

NOTE: This graph is a requirement of UL and should be used as reference only.

FIGURE 8 -
6" MODEL A-2 PRESSURE REGULATING VALVE WITH SPRING 09199
POSSIBLE FLOW RATE WHEN THE INLET PRESSURE IS BELOW THE OUTLET SET PRESSURE

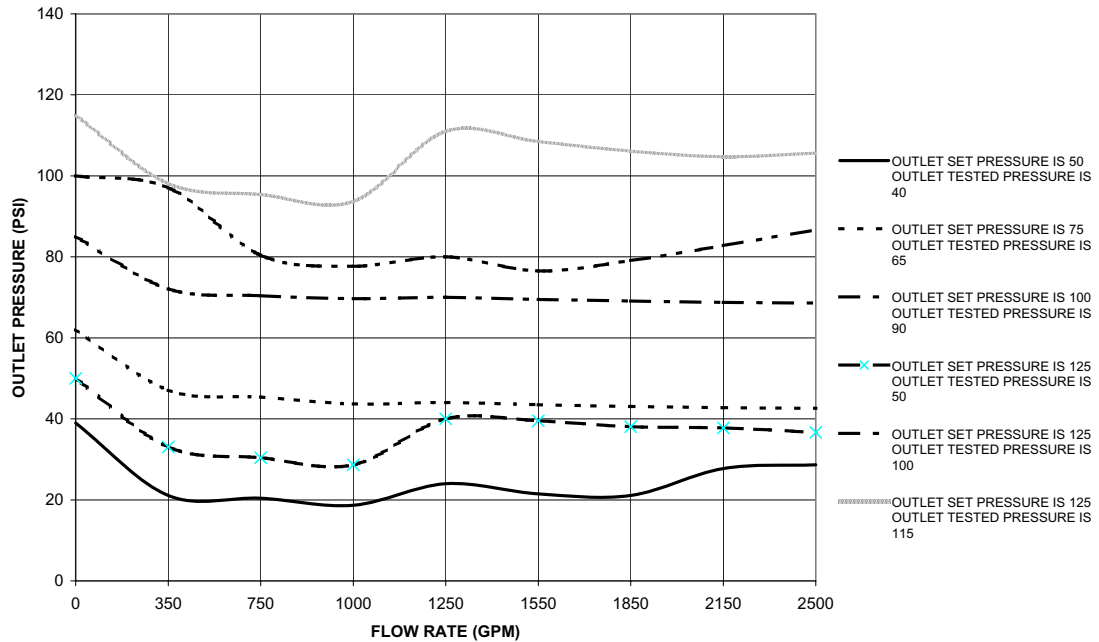

NOTE: This graph is a requirement of UL and should be used as reference only.



TECHNICAL DATA

PILOT PRESSURE REGULATING VALVE MODEL C-2

The Viking Corporation, 210 N Industrial Park Drive, Hastings MI 49058

Telephone: 269-945-9501 Technical Services 877-384-5464 Fax: 269-818-1680 Email: techsvcs@vikingcorp.com

**FIGURE 9 -
6" MODEL A-2 PRESSURE REGULATING VALVE WITH SPRING 09200
POSSIBLE FLOW RATE WHEN THE INLET PRESSURE IS BELOW THE OUTLET SET PRESSURE**

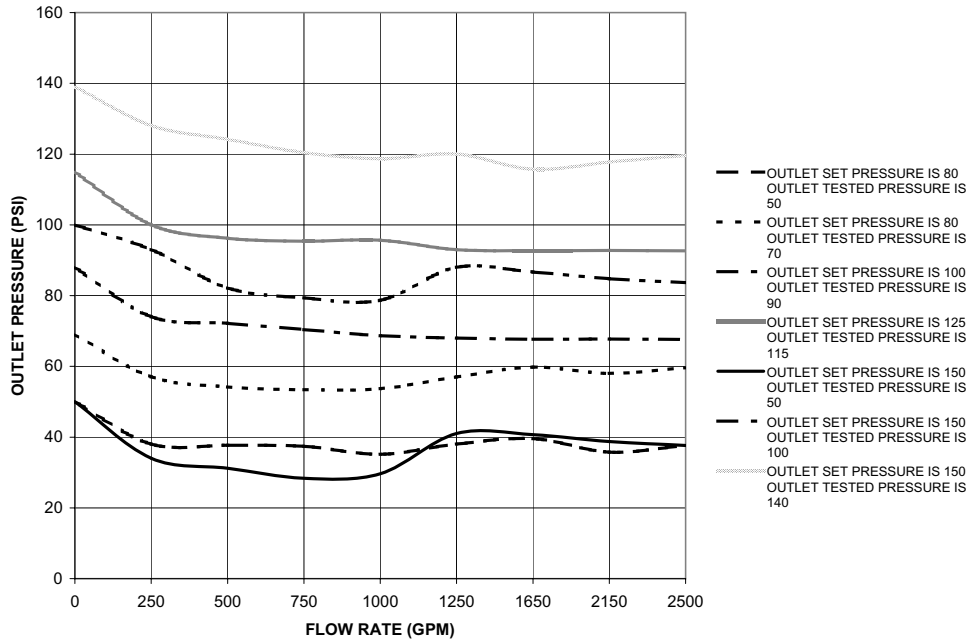

NOTE: This graph is a UL requirement and should be used as reference only.

**FIGURE 10 -
6" MODEL A-2 PRESSURE REGULATING VALVE WITH SPRING 09198
POSSIBLE FLOW RATE WHEN THE INLET PRESSURE FALLS BELOW THE OUTLET SET PRESSURE**

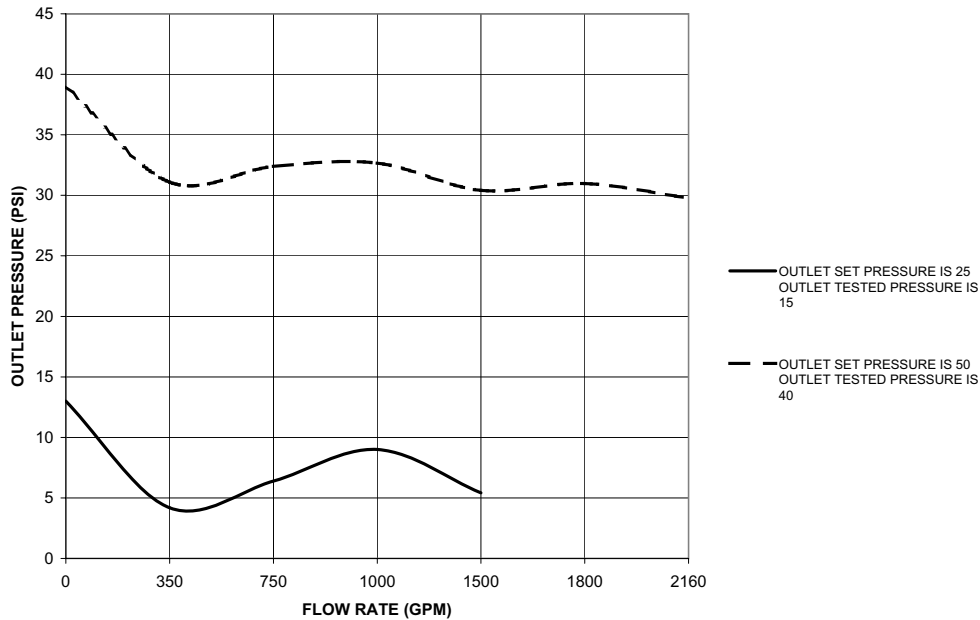

NOTE: This graph is a requirement of UL and should be used as reference only.



TECHNICAL DATA

PILOT PRESSURE REGULATING VALVE MODEL C-2

The Viking Corporation, 210 N Industrial Park Drive, Hastings MI 49058

Telephone: 269-945-9501 Technical Services 877-384-5464 Fax: 269-818-1680 Email: techsvcs@vikingcorp.com

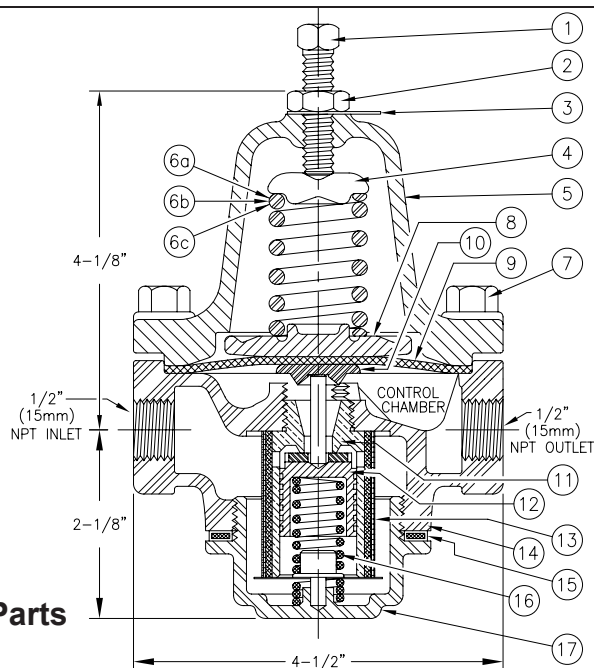

Figure 11 - Replacement Parts

ITEM NO.	PART NUMBER	DESCRIPTION	MATERIAL	NO. REQ'D.
1	--	Pressure Screw	Steel	1
2	--	Lock Nut	Steel	1
3	--	Identification Tag	Aluminum	1
4	--	Spring Button	Iron	1
5	--	Spring Chamber/Cover	Bronze	1
6a	09198	10-50 PSIG Pressure Spring	Steel	1
6b	09199	30-125 PSIG Pressure Spring	Steel	1
6c	09200	50-150 PSIG Pressure Spring	Steel	1
7	--	Assembly Bolts with Nuts	Steel	6
8	--	Pressure Plate	Cast Iron	1
9	*	Diaphragm	Buna-N Nylon	1
10	--	Pusher Post Button	Y-Brass	1
11	*	Cylinder/Seat	Naval Brass	1
12	*	Piston Assembly (Piston, Pusher Post, Composition Seat)	Y-Brass, Buna-N	1
13	*	Strainer Screen	Stainless Steel	1
14	--	Body	Bronze	1
15	*	Bottom Plug Gasket	Copper Covered	1
16	*	Piston Spring	302 Stainless Steel	1
17	--	Bottom Plug Assembly (Bottom Plug, Screen Washer, Screen Washer Spring, Piston Spring Support)	R-Brass, Y-Brass, 302 Stainless Steel	1

--Indicates replacement part not available

*Indicates replacement part only available in Sub-Assembly listed below.

SUB-ASSEMBLY

9, 11-13, 15, 16	12608	Pressure Regulating Pilot Valve Repair Kit		
------------------	-------	--	--	--

C-1 & C-2 parts are interchangeable.