



"Fast Clamp" Sway Brace Attachment

1000

Technical Features

- **Sizes available for bracing pipe (Nominal) :** DN25/1" to DN100/4". To be used together with bracing pipe DN25/1" and DN32/1 1/4".
- **Features :** No threading of bracing pipe required. Can be used as a longitudinal brace or a 4-way riser brace. All steel construction. Steel leaf spring ensures verification of proper installation.
- **Material :** Carbon steel.
- **Finish :** Plain or electrogalvanized.

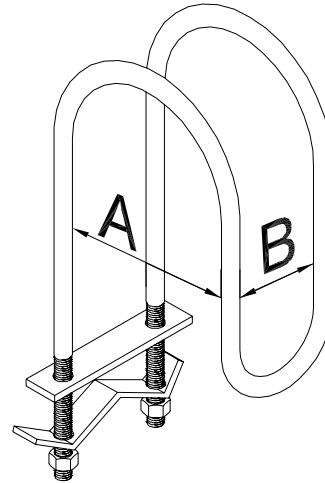
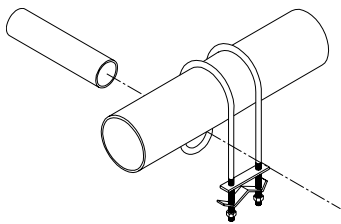

1 - When used with other Tolco® bracing products.



"Fast Clamp" Sway Brace Attachment - 1000

Physical Data

| "A" | | "B" | | Box Quantity | Box Weight (kg / lbs) | Reference | |
|------------------|------------------|-----------------------|------------------|--------------|-----------------------|------------|----------------|
| Nominal (metric) | Pipe Size (inch) | Nom. Bracing (metric) | Pipe Size (inch) | | | Europe | Asia / America |
| DN25 | 1" | DN25 | 1" | 25 | 9 / 20 | 1000100100 | 1000-0100 |
| DN32 | 1 1/4" | DN25 | 1" | 25 | 9 / 20 | 1000125100 | 1000-01250100 |
| DN40 | 1 1/2" | DN25 | 1" | 25 | 9 / 20 | 1000150100 | 1000-01500100 |
| DN50 | 2" | DN25 | 1" | 25 | 9 / 20 | 1000200100 | 1000-02000100 |
| DN65 | 2 1/2" | DN25 | 1" | 20 | 8 / 17 | 1000250100 | 1000-02500100 |
| DN80 | 3" | DN25 | 1" | 20 | 9 / 20 | 1000300100 | 1000-03000100 |
| DN100 | 4" | DN25 | 1" | 20 | 10 / 22 | 1000400100 | 1000-04000100 |
| DN25 | 1" | DN32 | 1 1/4" | 25 | 10 / 22 | 1000100125 | 1000-0100125 |
| DN32 | 1 1/4" | DN32 | 1 1/4" | 25 | 10 / 22 | 1000125125 | 1000-0125 |
| DN40 | 1 1/2" | DN32 | 1 1/4" | 25 | 10 / 22 | 1000150125 | 1000-0150125 |
| DN50 | 2" | DN32 | 1 1/4" | 25 | 10 / 22 | 1000200125 | 1000-0200125 |
| DN65 | 2 1/2" | DN32 | 1 1/4" | 20 | 9 / 20 | 1000250125 | 1000-0250125 |
| DN80 | 3" | DN32 | 1 1/4" | 20 | 9 / 20 | 1000300125 | 1000-0300125 |
| DN100 | 4" | DN32 | 1 1/4" | 20 | 11 / 23 | 1000400125 | 1000-0400125 |

Installation Instructions

Designed, tested, and approved to be used only with other Tolco® bracing products available from Viking SupplyNet.

The "Fast Clamp" Sway Brace Attachment is designed to be used in conjunction with Series 900 sway brace attachments all joined together with bracing pipe and installed according to National Fire Protection Association (NFPA) 13, Edition 1999 for bracing pipe against sway

and seismic disturbance. SPECIAL NOTE: Length of bracing pipe per the National Fire Protection Association (NFPA) 13.

Position Fast Clamp over the pipe to be braced. Slide bracing pipe through both attachment holes so that it extends at least 25mm (1") beyond the Fast Clamp. Tighten down the two bolts until the leaf spring flattens.