



Remote Inspector's Test

3011

Technical Features

- **Sizes Available (Nominal) :** DN25/1".
- **Pressure data :** Relief valve factory set to operate at 12 bar (175 psi).
- **Connections :** Threaded NPT.

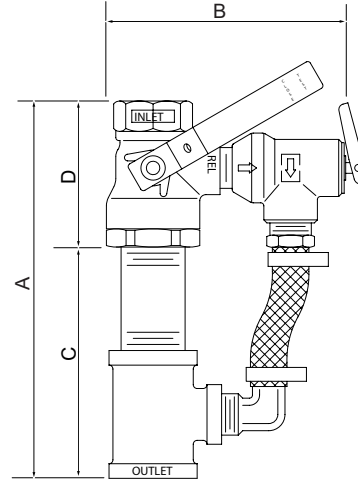

Test & Drain Valves

Remote Inspector's Test -3011

Physical Data

Nominal Size		Dimensions (mm / inch)				Orifice Nominal K-Factor		Reference		Weight (kg / lbs)
Metric	inch	A	B	C	D	Metric	US	Europe	America/Asia	
DN25	1"	201 / 7.9	118 / 4.7	124 / 4.9	75 / 3.1	40	2.8	30110375	30110037	1.5 / 3.3
						57	4.2	30110440	30110440	
						80	5.5	30110500	30110500	
						115	8.0	30110530	30110530	
						161	11.3	3011ELO	30110161	

Remote Inspector's Test -3011

Materials List

Item	Description	Material
1	Handle	Steel
2	Body	Bronze
3	Relief Valve	Bronze
4	Drain Tube	Nylobraid

