



TECHNICAL DATA

QUICK RESPONSE ELO PENDENT SPRINKLER VK377 (STORAGE-DENSITY/AREA)

The Viking Corporation, 210 N Industrial Park Drive, Hastings MI 49058

Telephone: 269-945-9501 Technical Services: 877-384-5464 Fax: 269-818-1680 Email: techsvcs@vikingcorp.com

1. DESCRIPTION

Viking Quick Response Extra-Large Orifice Pendent Sprinkler VK377 is a thermostatic glass bulb spray sprinkler available in several different finishes and temperature ratings to meet design requirements. The special Polyester, PTFE, and Electroless Nickel PTFE (ENT) coatings can be used in decorative applications where colors are desired. In addition, these coatings have been investigated for installation in corrosive atmospheres and are listed/approved as corrosion resistant as indicated in the Approval Charts. (Note: **FM Global approves ENT as corrosion-resistant.** FM Global has no approval classification for PTFE and Polyester coatings as corrosion resistant.)

The extra-large orifice provides greater flows at lower pressures than standard orifice or large orifice sprinklers. This feature allows reduced pipe sizing for hydraulically calculated sprinkler systems, which require high densities of water. Viking Quick Response Extra-Large Orifice Sprinklers may eliminate the need for a fire pump or reduce the size of the pump if it is required. On existing systems, replacing large orifice sprinklers with extra-large orifice sprinklers may provide the higher densities required to allow an increase in the hazard classification of an occupancy.

Viking quick response sprinklers may be ordered and/or used as open sprinklers (glass bulb and pip cap assembly removed) on deluge systems. Refer to Ordering Instructions below.



2. LISTINGS AND APPROVALS

 **cULus Listed:** Category VNIV

 **FM Approved:** Class 2020

 **VdS Approved:** Certificate G413049, G413051

 **LPCB Approved**

NOTE: Sprinkler VK377 is cULus Listed as a Specific Application Sprinkler as indicated in the Design Criteria section on page 70c.

Refer to Approval Chart 1 and Design Criteria on page 70c for cULus Listing requirements, and refer to Approval Chart 2 and Design Criteria on page 70d for FM Approval requirements that must be followed.

Viking Technical Data may be found on
The Viking Corporation's Web site at
<http://www.vikinggroupinc.com>.
The Web site may include a more recent
edition of this Technical Data Page.

3. TECHNICAL DATA

Specifications:

Available since 1993.

Maximum Working Pressure: 175 psi (12 bar). Factory tested hydrostatically to 500 psi (34.5 bar).

Thread size: See Approval Charts

Nominal K-Factor: 11.2 U.S. (161.3 metric*)

*Metric K-factor measurement shown is when pressure is measured in Bar. When pressure is measured in kPa, divide the metric K-factor shown by 10.0.

Glass-bulb fluid temperature rated to -65 °F (-55 °C)

Overall Length: 2-5/16" (58.7 mm)

Material Standards:

Sprinkler Frame: Brass UNS-C84400

Deflector: Brass UNS-C26000

Bulb: Glass, nominal 3 mm diameter

Pip Cap and Insert Assembly: Copper UNS-C11000 and Stainless Steel UNS-S30400

Compression Screw: Brass UNS-C36000

Belleville Spring Sealing Assembly: Nickel Alloy, coated on both sides with PTFE Tape

For PTFE Coated Sprinklers: Belleville Spring-Exposed, Screw-Nickel Plated, Pip Cap-PTFE Coated

For Polyester Coated Sprinklers: Belleville Spring-Exposed

For ENT Coated Sprinklers: Belleville Spring-Exposed, Screw and Pipcap-ENT plated

Ordering Information: (Also refer to the current Viking price list.)

Order Quick Response Extra-Large Orifice Pendent Sprinkler VK377 by first adding the appropriate suffix for the sprinkler finish and then the appropriate suffix for the temperature rating to the sprinkler base part number.

	TECHNICAL DATA	QUICK RESPONSE ELO PENDENT SPRINKLER VK377 (STORAGE-DENSITY/AREA)
---	-----------------------	--

The Viking Corporation, 210 N Industrial Park Drive, Hastings MI 49058

Telephone: 269-945-9501 Technical Services: 877-384-5464 Fax: 269-818-1680 Email: techsvcs@vikingcorp.com

Finish Suffix: Brass = A, Chrome = F, White Polyester = M-/W, Black Polyester = M-/B, Black PTFE = N, and ENT = JN
 Temperature Suffix (°F/°C): 155°/68° = B, 175°/79° = D, 200°/93° = E, 286°/141° = G, OPEN = Z (PTFE only).
 For example, sprinkler VK377 with a Brass finish and a 155 °F/68 °C temperature rating = Part No. 08337AB

Available Finishes And Temperature Ratings: Refer to Table 1

Accessories: (Also refer to the “Sprinkler Accessories” section of the Viking data book.)

Sprinkler Wrenches:

- A. Standard Wrench: Part No. 05118CW/B (available since 1981).
 - B. Wrench for recessed and/or coated sprinklers: Part No. 11663W/B** (available since 2001)
- **A ½” ratchet is required (not available from Viking).

Sprinkler Cabinets:

- A. Six-head capacity: Part No. 01724A (available since 1971)
- B. Twelve-head capacity: Part No. 01725A (available since 1971)

4. INSTALLATION

Refer to appropriate NFPA Installation Standards.

5. OPERATION

During fire conditions, when the temperature around the sprinkler reaches its operating temperature, the heat-sensitive liquid in the glass bulb expands, causing the bulb to shatter, releasing the pip cap and sealing spring assembly. Water flowing through the sprinkler orifice strikes the sprinkler deflector, forming a uniform spray pattern to extinguish or control the fire.

6. INSPECTIONS, TESTS AND MAINTENANCE

Refer to NFPA 25 for Inspection, Testing and Maintenance requirements.

7. AVAILABILITY

Viking Quick Response Extra-Large Orifice Pendent Sprinklers are available through a network of domestic and international distributors. See The Viking Corporation web site for the closest distributor or contact The Viking Corporation.

8. GUARANTEE

For details of warranty, refer to Viking’s current list price schedule or contact Viking directly.

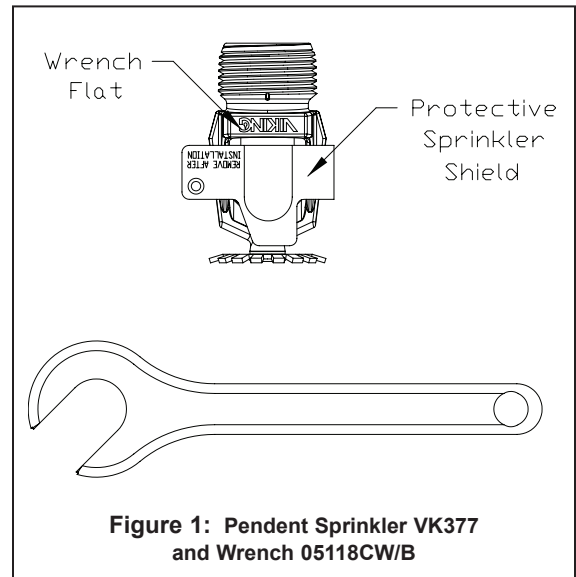

Figure 1: Pendent Sprinkler VK377 and Wrench 05118CW/B

TABLE 1: AVAILABLE SPRINKLER TEMPERATURE RATINGS AND FINISHES

Sprinkler Temperature Classification	Sprinkler Nominal Temperature Rating ¹	Maximum Ambient Ceiling Temperature ²	Bulb Color
Ordinary	155 °F (68 °C)	100 °F (38 °C)	Red
Intermediate	175 °F (79 °C)	150 °F (65 °C)	Yellow
Intermediate	200 °F (93 °C)	150 °F (65 °C)	Green
High	286 °F (141 °C)	225 °F (107 °C)	Blue

Sprinkler Finishes: Brass, Chrome, White Polyester, Black Polyester, Black PTFE, and ENT

Corrosion-Resistant Coatings³: White Polyester, Black Polyester, Black PTFE, and ENT

Footnotes

- ¹ The sprinkler temperature rating is stamped on the deflector.
- ² Based on NFPA-13. Other limits may apply, depending on fire loading, sprinkler location, and other requirements of the Authority Having Jurisdiction. Refer to specific installation standards.
- ³ The corrosion-resistant coatings have passed the standard corrosion test required by the approving agencies indicated in the Approval Charts. These tests cannot and do not represent all possible corrosive environments. Prior to installation, verify through the end-user that the coatings are compatible with or suitable for the proposed environment. For automatic sprinklers, the coatings indicated are applied to the exposed exterior surfaces only. Note that the spring is exposed on sprinklers with Polyester, PTFE, and ENT coatings. For PTFE coated open sprinklers only, the waterway is coated. For all ENT coated sprinklers, the waterway is coated.

	<h2 style="margin: 0;">TECHNICAL DATA</h2>	<p>QUICK RESPONSE ELO PENDENT SPRINKLER VK377 (STORAGE-DENSITY/AREA)</p>
---	--	---

The Viking Corporation, 210 N Industrial Park Drive, Hastings MI 49058
Telephone: 269-945-9501 Technical Services: 877-384-5464 Fax: 269-818-1680 Email: techsvcs@vikingcorp.com

Approval Chart 1 (UL)												
Quick Response Extra-Large Orifice Pendent Sprinkler VK377 Maximum 175 PSI (12 Bar) WWP												
Base Part Number ¹	SIN	Sprinkler Style	Thread Size		Nominal K-Factor		Overall Length		Listings and Approvals ³ (Refer also to Design Criteria below.)			
			NPT	BSP	U.S.	metric ²	Inches	mm	cULus ^{4,5}	NYC	VdS	LPCB
08337	VK377	Pendent	3/4"	20 mm	11.2	161.3	2-5/16	58.7	A1Y, B1Z, B2X, A2W	See Footnote 6.	A1	A1
<p>Approved Temperature Ratings</p> <p>A - 155 °F (68 °C), 175 °F (79 °C), 200 °F (93 °C), and 286 °F (141 °C)</p> <p>B - 155 °F (68 °C), 175 °F (79 °C), and 200 °F (93 °C)</p>			<p>Approved Finishes</p> <p>1 - Brass, Chrome, White Polyester⁷, Black Polyester⁷, and Black PTFE⁷</p> <p>2 - ENT⁷</p>				<p style="text-align: center;">Escutcheons</p> <p>W - Standard surface-mounted escutcheons only</p> <p>X - Standard surface-mounted escutcheons or recessed with the Micromatic Model E-1 Escutcheon.</p> <p>Y - Standard surface-mounted escutcheons or the Microfast® Model F-1 Adjustable Escutcheon</p> <p>Z - Standard surface-mounted escutcheon or the Viking Microfast® Model F-1 Adjustable Escutcheon or recessed with the Viking Micromatic® Model E-1, E-2, or E-3 Recessed Escutcheon</p>					
<p>Footnotes</p> <p>¹ Base part number shown. For complete part number, refer to Viking's current price schedule.</p> <p>² Metric K-factor measurement shown is when pressure is measured in Bar. When pressure is measured in kPa, divide the metric K-factor shown by 10.0.</p> <p>³ This table shows the listings and approvals available at the time of printing. Other approvals may be in process.</p> <p>⁴ Listed by Underwriters Laboratories Inc. for use in the U.S. and Canada.</p> <p>⁵ cULus-Listed only for use in wet pipe sprinkler systems (or preaction systems qualifying as wet systems).</p> <p>⁶ Meets New York City requirements, effective July 1, 2008.</p> <p>⁷ cULus Listed as corrosion-resistant.</p>												

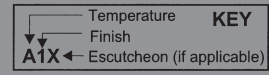

DESIGN CRITERIA - UL
(Also refer to Approval Chart 1 above.)

cULus Listing Requirements:

Quick Response Extra-Large Orifice Pendent Sprinkler VK377 is cULus Listed for installation in accordance with the latest edition of NFPA 13 for standard pendent spray sprinklers:

- Designed for use in hazard occupancies up to and including Ordinary Hazard Group II with a minimum operating pressure of 7 psi (0.5 bar).
- Also cULus Listed for use in High-Piled Storage Occupancies as defined in NFPA 13 with a minimum operating pressure of 7 psi (0.5 bar).
- Listed only for use in wet pipe sprinkler systems (or preaction systems qualifying as wet systems).
- The sprinkler installation and obstruction rules contained in NFPA 13 for standard spray pendent sprinklers must be followed.

Also:

When acceptable to the Authority Having Jurisdiction, Viking Quick Response Extra-Large Orifice Sprinkler VK377 may be used as a specific-application head with a density of .6/2000 ft.² for wet systems (or preaction systems qualifying as wet systems) to protect single-, double-, multiple-row, and portable rack storage of Class I-IV, Group A and B Plastics, cartoned, expanded or unexpanded, as well as exposed unexpanded when the following conditions are met:

- A maximum storage height of 20 ft. (6.1 m).
- A maximum ceiling height of 25 ft. (7.6 m).
- A 36-inch (914 mm) minimum clearance from the deflector to the top of storage.

Otherwise, design to the appropriate density/area requirements.

IMPORTANT: Always refer to Bulletin Form No. F_091699 - Care and Handling of Sprinklers. Also refer to pages QR1-3 for general care, installation, and maintenance information. Viking sprinklers are to be installed in accordance with the latest edition of Viking technical data, the appropriate standards of NFPA, LPCB, APSAD, VdS or other similar organizations, and also with the provisions of governmental codes, ordinances, and standards, whenever applicable.

	TECHNICAL DATA	QUICK RESPONSE ELO PENDENT SPRINKLER VK377 (STORAGE-DENSITY/AREA)
---	-----------------------	--

The Viking Corporation, 210 N Industrial Park Drive, Hastings MI 49058
 Telephone: 269-945-9501 Technical Services: 877-384-5464 Fax: 269-818-1680 Email: techsvcs@vikingcorp.com

Approval Chart 2 (FM)									
Quick Response Extra-Large Orifice Pendent Sprinkler VK377 Maximum 175 PSI (12 Bar) WWP									
Base Part Number ¹	SIN	Sprinkler Style	Thread Size		Nominal K-Factor		Overall Length		FM Approvals ³ (Refer also to Design Criteria below.)
			NPT	BSP	U.S.	metric ²	Inches	mm	
08337	VK377	Pendent	3/4"	20 mm	11.2	161.3	2-5/16	58.7	A1X
Approved Temperature Ratings A - 155 °F (68 °C), 175 °F (79 °C), 200 °F (93 °C), and 286 °F (141 °C)					Approved Finish 1 - Brass and ENT ⁴			Escutcheons X - Standard surface-mounted escutcheons	
Footnotes									
¹ Base part number shown. For complete part number, refer to Viking's current price schedule. ² Metric K-factor measurement shown is when pressure is measured in Bar. When pressure is measured in kPa, divide the metric K-factor shown by 10.0. ³ This table shows the FM Approvals available at the time of printing. Other approvals may be in process. ⁴ FM approved as corrosion resistant.									

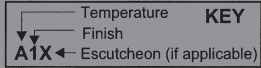

DESIGN CRITERIA - FM
(Also refer to Approval Chart 2 above.)

FM Approval Requirements:

Quick Response Extra-Large Orifice Pendent Sprinkler VK377 is FM Approved as a quick response pendent **Non-Storage** sprinkler, and as a quick response pendent **Storage** sprinkler as indicated in the FM Approval Guide. For specific application and installation requirements, reference the latest applicable FM Loss Prevention Data Sheets (including 2-0 and 8-9). FM Global Loss Prevention Data Sheets contain guidelines relating to, but not limited to: minimum water supply requirements, hydraulic design, ceiling slope and obstructions, minimum and maximum allowable spacing, and deflector distance below the ceiling.

NOTE: The FM installation guidelines may differ from cULus and/or NFPA criteria.

IMPORTANT: Always refer to Bulletin Form No. F_091699 - Care and Handling of Sprinklers. Also refer to pages QR1-3 for general care, installation, and maintenance information. Viking sprinklers are to be installed in accordance with the latest edition of Viking technical data, the appropriate standards of NFPA, FM Global, LPCB, APSAD, VdS or other similar organizations, and also with the provisions of governmental codes, ordinances, and standards, whenever applicable.



TECHNICAL DATA

**QUICK RESPONSE
ELO PENDENT
SPRINKLER VK377
(STORAGE-DENSITY/AREA)**

The Viking Corporation, 210 N Industrial Park Drive, Hastings MI 49058

Telephone: 269-945-9501 Technical Services: 877-384-5464 Fax: 269-818-1680 Email: techsvcs@vikingcorp.com

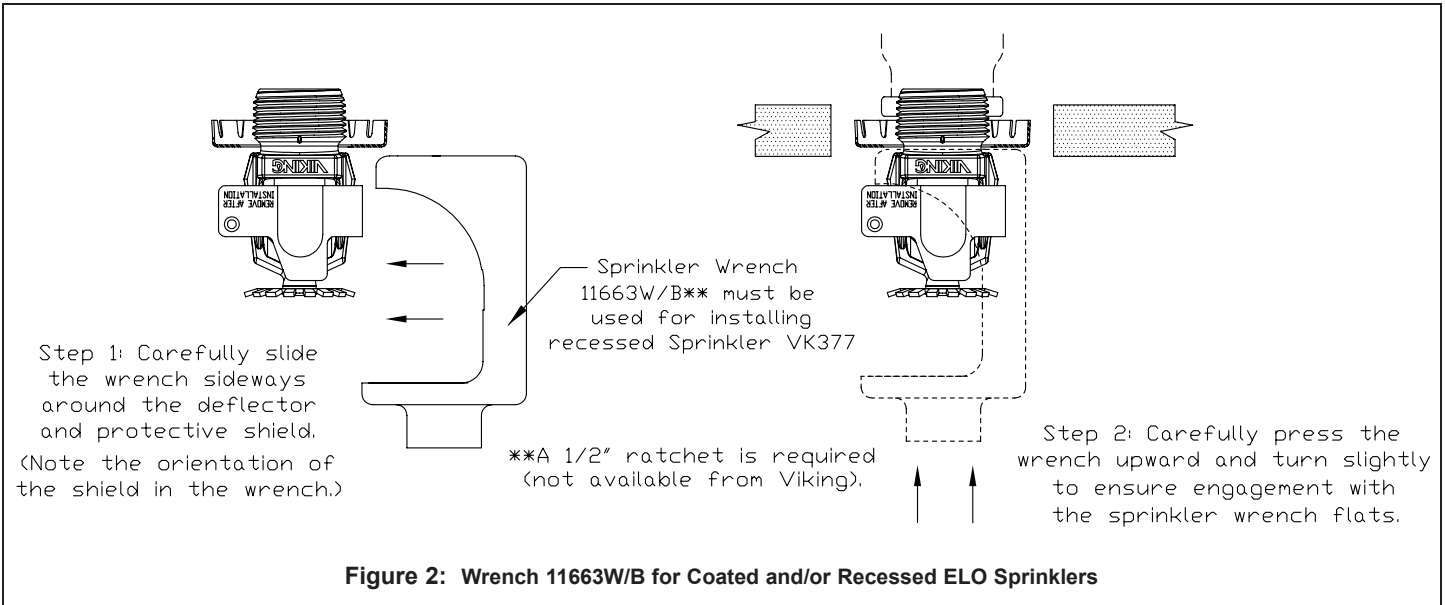

Figure 2: Wrench 11663W/B for Coated and/or Recessed ELO Sprinklers

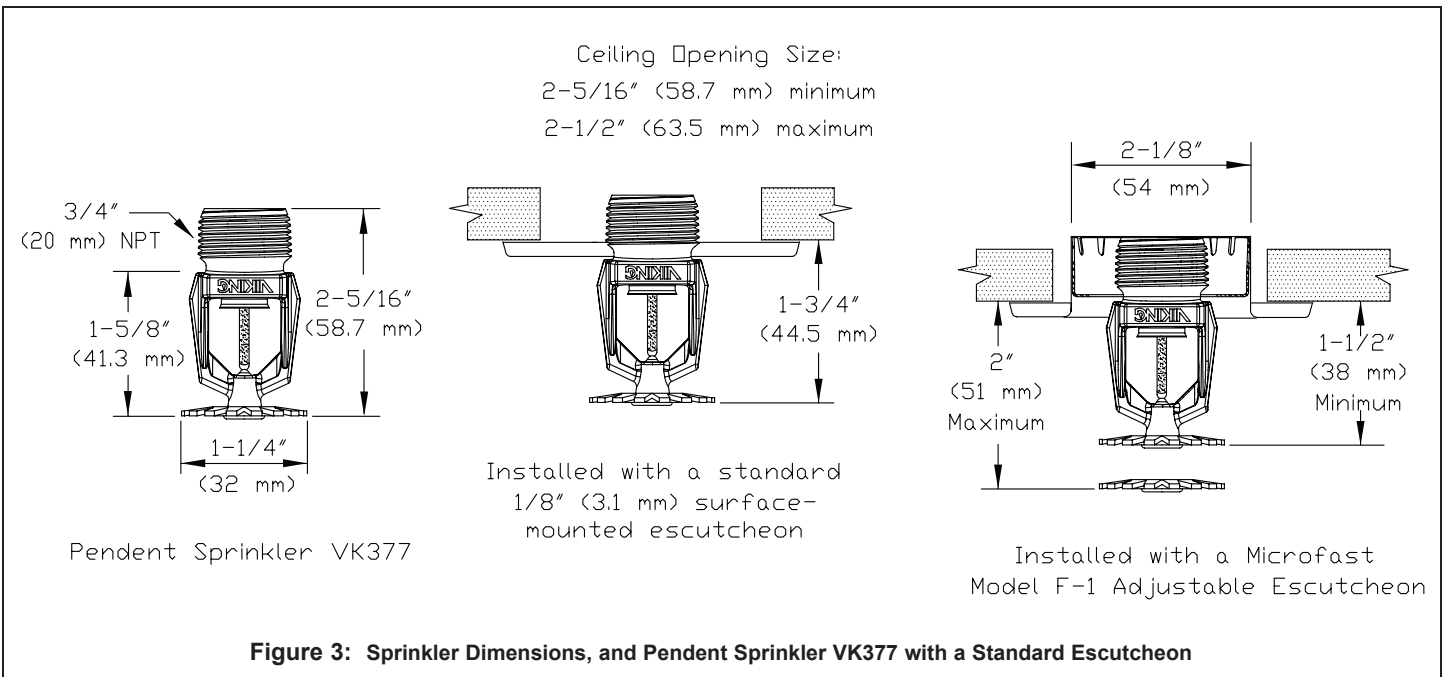

Figure 3: Sprinkler Dimensions, and Pendent Sprinkler VK377 with a Standard Escutcheon



TECHNICAL DATA

**QUICK RESPONSE
ELO PENDENT
SPRINKLER VK377
(STORAGE-DENSITY/AREA)**

The Viking Corporation, 210 N Industrial Park Drive, Hastings MI 49058

Telephone: 269-945-9501 Technical Services: 877-384-5464 Fax: 269-818-1680 Email: techsvcs@vikingcorp.com

