

	<h2 style="margin: 0;">TECHNICAL DATA</h2>	<h3 style="margin: 0;">ESFR DRY PENDENT SPRINKLER VK502 (K14.0)</h3>
---	--	--

The Viking Corporation, 210 N Industrial Park Drive, Hastings MI 49058
Telephone: 269-945-9501 Technical Services: 877-384-5464 Fax: 269-818-1680 Email: techsvcs@vikingcorp.com

1. DESCRIPTION

Viking Early Suppression Fast Response (ESFR) Dry Pendent Sprinkler VK502 is a fast response fusible element type sprinkler designed for use in storage areas subject to freezing and supplied from a wet system in an adjacent heated area. With a 14.0 (202 metric*) nominal K-Factor and special deflector, this sprinkler produces large, high-momentum water droplets in a hemispheric pattern below the deflector. This permits penetration of the fire plume and direct wetting of the burning fuel surface while cooling the atmosphere early in the development of a high-challenge fire.

The dry ESFR sprinkler consists of a fusible element style ESFR sprinkler permanently secured to a special supply nipple. The sprinkler assembly features a sealed brass inlet that's grooved or threaded. Also included with the ESFR dry sprinkler are two insulating boot assemblies (optional) to help seal the clearance space around the dry sprinkler barrel. When properly installed, the seal decreases the potential for leakage of air through the opening in the ceiling and consequent formation of condensate around the sprinkler connection on the system piping. In freezer installations, condensation can lead to ice build-up, which could inhibit sprinkler operation or cause premature sprinkler operation. The dry sprinkler boot assembly is intended to slow the exchange of air between the inside and outside of the freezer (or any dry sprinkler installation) to help prevent humidity and temperature differential in the area around the sprinkler. The rubber seal is designed with a material that will not drip when exposed to open flame. This protects the deflector from acquiring material that would impede its water distribution characteristics.

NOTICE: Viking recommends use of the included insulating boot assemblies in accordance with the installation instructions in this technical data page. Insulating boot assemblies (optional) are recommended to be installed on smooth, flat, and clean surfaces. There are specific situations, such as corrugated ceiling panels, where alternative penetration sealing methods are utilized. For additional information contact Viking Technical Services.

ESFR Dry Sprinkler VK502 requires storage to be arranged single row, double row, or multiple row open rack storage (no open-top containers or solid shelves). In-rack sprinklers are not required. ESFR Dry Sprinkler VK502 shall be located in accordance with Design Criteria on page 122m-n and the latest recognized storage installation rules of NFPA 13.

Viking ESFR Dry Pendent VK502 Sprinklers provide protection of most common storage materials, open-framed rack storage arrangements of Class I, II, III, and IV commodities, and cartoned unexpanded plastic up to 35ft. (10.7m) storage with a 40ft. (12.0m) ceiling height*.

- For specific application and installation requirements, reference the latest applicable FM Loss Prevention Data Sheets (including Data Sheet 2-0 and 8-9).

*Refer the Approval Chart and Design Criteria on page 122n for FM Approval requirements that must be followed.

*Refer to the Approval Chart and Design Criteria on page 122m for UL listing requirements that must be followed.

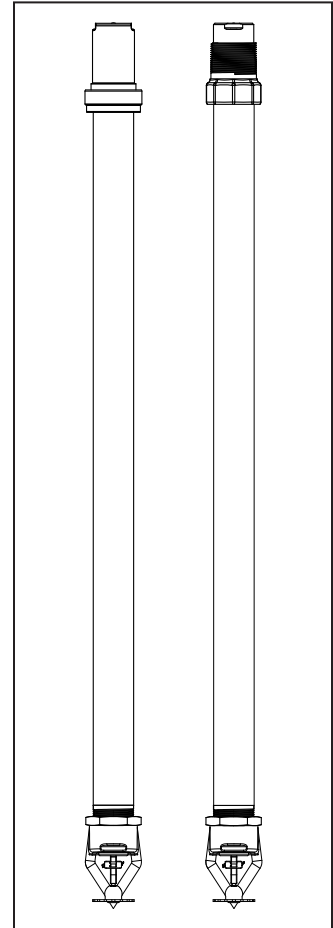

**ESFR Sprinkler VK502
(Grooved and Threaded)**

2. LISTINGS AND APPROVALS

 **UL Listed: Category VNVH**
Refer to the Approval Chart and Design Criteria on page 122m for UL Listing requirements that must be followed.

 **FM Approved: Class 2008**
Refer to the Approval Chart and Design Criteria on page 122n for FM Approval requirements that must be followed.

 **ESFR DRY SPRINKLERS CAN ONLY BE INSTALLED IN WET SYSTEMS! NOT FOR INSTALLATION IN DRY OR PREACTION SYSTEMS.**

3. TECHNICAL DATA

Specifications:
Available since 2012.
Tube diameter: 1-11/16" (43.86 mm)

Viking Technical Data may be found on
The Viking Corporation's Web site at
<http://www.vikinggroupinc.com>.
The Web site may include a more recent
edition of this Technical Data Page.

	TECHNICAL DATA	ESFR DRY PENDENT SPRINKLER VK502 (K14.0)
---	-----------------------	---

The Viking Corporation, 210 N Industrial Park Drive, Hastings MI 49058

Telephone: 269-945-9501 Technical Services: 877-384-5464 Fax: 269-818-1680 Email: techsvcs@vikingcorp.com

Minimum Operating Pressure: Refer to NFPA 13 or FM Loss Prevention Data Sheets 8-9.
 Maximum Working Pressure: 175 psi (12 bar). Factory tested hydrostatically to 500 psi (34.5 bar).

**Connections: 2" grooved (refer to Figures 1 and 2) or
 1-1/2" NPT or BSP Threaded (refer to Figures 3 and 4)**

Nominal K-Factor: 14.0 U.S. (202 metric*)

*Metric K-factor measurement shown is when pressure is measured in bar. When pressure is measured in kPa, divide the metric K-factor shown by 10.0.

Deflector Diameter: 1-13/32" (35.7 mm)
 Overall Length: 18-5/8" (473 mm), 24-5/8" (625 mm), 30-5/8" (778 mm), 36-5/8" (930 mm)

Patent Pending

Insulating Boot Assemblies (2 ea): The boot consists of a rubber foam seal covered with a two-piece ring fastened to the ceiling or deck with two screws.

Outside Diameter: 6" (152 mm)

Depth: 1" (25 mm)

Material Standards:

Sprinkler Frame Casting: Brass UNS-C84400

Deflector: Phosphor Bronze UNS-C51000

Seat: Brass UNS-C36000

Belleville Spring Sealing Assembly: Nickel Alloy, coated on both sides with Polytetrafluoroethylene (PTFE) Tape

Spring Base: Brass UNS-C31400 or UNS-C31600

Back-Up Nut: Brass UNS-C36000

Compression Screw: Stainless Steel UNS-S31603

Trigger and Support: Stainless Steel UNS-S31600

Fusible Element Assembly: Beryllium Nickel, coated with polyurethane

Tube: ERW Steel Tube ASTM A-513, Brass UNS-C36000

Orifice: Brass UNS-C36000

Inlet Casting : Brass UNS-C84400

Support (Internal): Brass UNS-C36000

Barrel: Steel Tube ASTM A-513, Electrodeposited Epoxy Base finish, Brass UNS-C36000

Boot Assemblies:

Seal: Neoprene/EPDM/SBR

Over Seal Ring and Under Seal Ring: Cold Rolled Steel

Finish: White Paint

#10 Screws: Stainless Steel

Ordering Information: (Also refer to the current Viking price list.)

Order ESFR Dry Pendent Sprinkler VK502 by first adding the appropriate suffix for the sprinkler finish, the appropriate suffix for the temperature rating. Note: Sprinkler VK502 is available in four lengths and three different inlet styles, with a different base part number for each length and inlet.

Sprinkler Base Part Numbers:

TABLE 1: SPRINKLER BASE PART NUMBERS							
Sprinkler Description			Part Number	Sprinkler Description			Part Number
Overall Length	Inlet Style	Part Number		Overall Length	Inlet Style	Part Number	
18-5/8" (473 mm)	2" Grooved	18702	30-5/8" (778 mm)	2" Grooved	18710		
18-5/8" (473 mm)	1-1/2" NPT Threaded	18703	30-5/8" (778 mm)	1-1/2" NPT Threaded	18711		
18-5/8" (473 mm)	1-1/2" BSP Threaded	18704	30-5/8" (778 mm)	1-1/2" BSP Threaded	18712		
24-5/8" (625 mm)	2" Grooved	18706	36-5/8" (930 mm)	2" Grooved	18176		
24-5/8" (625 mm)	1-1/2" NPT Threaded	18707	36-5/8" (930 mm)	1-1/2" NPT Threaded	18177		
24-5/8" (625 mm)	1-1/2" BSP Threaded	18708	36-5/8" (930 mm)	1-1/2" BSP Threaded	18178		

	TECHNICAL DATA	ESFR DRY PENDENT SPRINKLER VK502 (K14.0)
---	-----------------------	---

The Viking Corporation, 210 N Industrial Park Drive, Hastings MI 49058
 Telephone: 269-945-9501 Technical Services: 877-384-5464 Fax: 269-818-1680 Email: techsvcs@vikingcorp.com

TABLE 2: AVAILABLE SPRINKLER TEMPERATURE RATINGS AND FINISHES

Sprinkler Temperature Classification	Sprinkler Nominal Temperature Rating ¹	Maximum Ambient Ceiling Temperature ²	Frame Paint Color
Ordinary	165 °F (74 °C)	100 °F (38 °C)	None

Sprinkler Finish: Brass

Footnotes

- ¹ The sprinkler temperature rating is stamped on the deflector.
² Based on NFPA-13. Other limits may apply, depending on fire loading, sprinkler location, and other requirements of the Authority Having Jurisdiction. Refer to specific installation standards.

Finish Suffix: Brass = A
 Temperature Suffix (°F/°C): 165°/74° = C
 For example, sprinkler VK502 with 2" grooved connections, Brass finish and a 165 °F/74 °C temperature rating = Part No. 18176AC (includes 2 insulating boot assemblies).

Available Finishes And Temperature Ratings:

Refer to Table 2.

Accessories: (Also refer to the "Sprinkler Accessories" section of the Viking data book.)

Sprinkler Wrenches:

- A. For Grooved Sprinklers: Use a crescent wrench or socket applied on the grooved coupling
- B. For Threaded Sprinklers: Use a pipe wrench applied on the inlet housing

Replacement Insulating Boot Assemblies:

- A. Base Part No. 19930

4. INSTALLATION



Viking sprinklers are manufactured and tested to meet rigid requirements of the approving agency. The sprinklers are designed to be installed in accordance with recognized installation standards. System design must be based on ESFR design guidelines described in the latest edition of Viking technical data, applicable FM Global Loss Prevention Data Sheets, the latest NFPA Standards, the Authorities Having Jurisdiction, and also with the provisions of governmental codes, ordinances, and standards whenever applicable. Deviation from the standards or any alteration to the sprinkler after it leaves the factory including, but not limited to: painting, plating, coating, or modification, may render the sprinkler inoperative and will automatically nullify the approval and any guarantee made by The Viking Corporation.

Sprinklers must be handled with care. They must be stored in a cool, dry place in their original shipping container. Never install sprinklers that have been dropped or damaged in any way. Such sprinklers should be destroyed immediately. **NOTICE:** Wet pipe systems must be provided with adequate heat.

Viking ESFR Dry Sprinklers are to be installed into the 2" grooved or 1-1/2" threaded run of malleable, ductile iron tee fittings that meet the dimensional requirements of ANSI B16.3 (Class 150), or cast iron threaded tee fittings that meet the dimensional requirements of ANSI B16.4 (Class 125), even at branch line ends.

- **DO NOT** install the dry sprinkler into a threaded elbow, coupling, or any other fitting that could interfere with thread penetration. Such installation would damage the brass seal.
 - **NEVER** try to modify dry sprinklers. They are manufactured for specific dimensions and must NOT be modified.
- A. The sprinklers must be installed after the piping is in place to prevent mechanical damage. Before installing, be sure to have the appropriate sprinkler model and style, with the correct orifice size, temperature rating, and response characteristics.
 - B. For grooved sprinklers, with the sprinkler contained in the plastic protective shield, apply a lube such as Gruvlok Xtreme™. For threaded sprinklers, apply a small amount of pipe-joint compound or tape to the external threads of the barrel only, while taking care not to allow a build-up of compound or tape over the brass inlet and seal.



TECHNICAL DATA

ESFR DRY PENDENT SPRINKLER VK502 (K14.0)

The Viking Corporation, 210 N Industrial Park Drive, Hastings MI 49058

Telephone: 269-945-9501 Technical Services: 877-384-5464 Fax: 269-818-1680 Email: techsvcs@vikingcorp.com

Approval Chart

ESFR Dry Pendent Sprinkler VK502

Maximum 175 PSI (12 bar) WWP

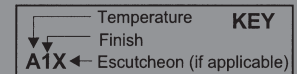

Base Part Number ¹				SIN	Connections	Nominal K-Factor		Listings and Approvals ^{3,4,5} (Refer also to Design Criteria on page 122d.)					
18-5/8" (473 mm)	24-5/8" (625 mm)	30-5/8" (778 mm)	36-5/8" (930 mm)			U.S.	metric ²	UL	FM	VdS	LPCB	CE	⚙
18702	18706	18710	18176	VK502	2" Grooved	14.0	202	A1	A1	--	--	--	--
18703	18707	18711	18177	VK502	1-1/2" NPT Threaded	14.0	202	A1	A1	--	--	--	--
18704	18708	18712	18178	VK502	1-1/2" BSP Threaded	14.0	202	A1	A1	--	--	--	--
Approved Temperature Rating A - 165 °F (74 °C)								Approved Finish 1 - Brass					

Footnotes

- ¹ Base part number shown. For complete part number, refer to the price list.
- ² Metric K-Factor measurement shown is when pressure is measured in bar. When pressure is measured in kPa, divide the metric K-Factor shown by 10.0.
- ³ This chart shows listings and approvals available at the time of printing. Other approvals may be in process.
- ⁴ FM Approved as a quick response pendent **Non-Storage** sprinkler and also FM Approved as a quick response pendent **Storage** sprinkler. Refer to Design Criteria on page 122n.
- ⁵ Refer to the latest standards of NFPA 13.

DESIGN CRITERIA - UL

(Also refer to the Approval Chart above.)

UL Listing Requirements: ESFR Dry Pendent Sprinkler VK502 is UL Listed as indicated in the Approval Chart for installation in accordance with the latest appropriate NFPA standards (including NFPA 13) for ESFR Pendent K14.0 (202) Sprinklers, for protecting cold storage of certain specified materials with rack storage up to 35 ft (10.7 m) high in buildings with 40 ft (12.2 m) high ceilings with NO in-rack sprinklers.

System Type: ESFR DRY SPRINKLERS CAN ONLY BE INSTALLED IN WET SYSTEMS!

Maximum Roof or Ceiling Slope: 2 in 12 (167 mm/m or 9.5 degrees).

Sprinkler Position: Approved for use only in the pendent position. Align the deflector parallel with the ceiling or roof.

Deflector Position: Position the deflector a maximum of 14" (356 mm) and a minimum of 6" (152 mm) below the ceiling.

Clearance Opening Diameter: Refer to Figures 1-4. **NOTICE:** The dry sprinkler boot must seat and seal against the smooth surface of the top of the freezer in order to close the air gap.

Sprinkler Fitting: Install into the 2" grooved or 1-1/2" threaded run of malleable, ductile iron tee fittings that meet the dimensional requirements of ANSI B16.3 (Class 150), or cast iron threaded tee fittings that meet the dimensional requirements of ANSI B16.4 (Class 125) only.

Deflector Distance from Walls: At least 4" (102 mm) from walls, and no more than one-half the allowable distance permitted between sprinklers.

Clearance from Deflector to Top of Storage: At least 36" (914 mm).

Maximum Distance Between Sprinklers: The maximum area of coverage allowed per sprinkler is 100 ft² (9.3 m²)**.

- For buildings over 30 ft (9.1 m) high, spacing between sprinklers and/or branch lines must be from 8 to 10 ft (2.4 to 3.1 m)**.
- For building heights up to 30 ft (9.1 m), the spacing allowed between sprinklers and/or branch lines is 8 to 12 ft (2.4 to 3.7 m), provided the area covered per sprinkler does not exceed the maximum 100 ft² (9.3 m²) allowed**.

**Refer to the Installation Standards for permissible deviations from the maximum sprinkler spacing rules above, to eliminate obstructions created by trusses and bar joists when using ESFR sprinklers.

Minimum Area of Coverage: The minimum area of coverage allowed per sprinkler is 64 ft² (5.8 m²).

IMPORTANT: Always refer to Bulletin Form No. F_091699 - Care and Handling of Sprinklers. Viking ESFR Dry Pendent Sprinklers are to be installed in accordance with the latest edition of Viking technical data, the latest standards of NFPA, and any other Authorities Having Jurisdiction, and also with provisions of governmental codes, ordinances, and standards whenever applicable.



TECHNICAL DATA

ESFR DRY PENDENT SPRINKLER VK502 (K14.0)

The Viking Corporation, 210 N Industrial Park Drive, Hastings MI 49058

Telephone: 269-945-9501 Technical Services: 877-384-5464 Fax: 269-818-1680 Email: techsvcs@vikingcorp.com

DESIGN CRITERIA - FM

(Also refer to the Approval Chart on page 122m.)

FM Approval Requirements:

1. Sprinkler VK502 is FM Approved as a quick response pendent **Storage** sprinkler as indicated in the FM Approval Guide.
 - For specific application and installation requirements, reference the latest applicable FM Loss Prevention Data Sheets (including Data Sheets 2-0 and 8-9).
2. Sprinkler VK502 is also FM Approved as a quick response pendent **Non-Storage** sprinkler as indicated in the FM Approval Guide.
 - For specific application and installation requirements, reference the latest applicable FM Loss Prevention Data Sheets (including Data Sheet 2-0).

FM Global Loss Prevention Data Sheets contain guidelines relating to, but not limited to: minimum water supply requirements, hydraulic design, ceiling slope and obstructions, minimum and maximum allowable spacing, and deflector distance below the ceiling.

NOTICE: The FM installation guidelines may differ from NFPA criteria.

IMPORTANT: Always refer to Bulletin Form No. F_091699 - Care and Handling of Sprinklers. Viking ESFR Dry Pendent Sprinklers are to be installed in accordance with the latest edition of Viking technical data, the latest standards of NFPA, and any other Authorities Having Jurisdiction, and also with provisions of governmental codes, ordinances, and standards whenever applicable.

- C. **For grooved sprinklers, use a crescent wrench or socket applied to a coupling over the sprinkler inlet connection. To install threaded sprinklers, use a pipe wrench applied to the sprinkler inlet housing. With the sprinkler contained in the protective shield, install the sprinkler onto the piping, while taking care not to damage the sprinkler.**
 - DO NOT use any other type of wrench, as this could damage the unit.
 - DO NOT use the sprinkler deflector or fusible element to start or thread the sprinkler into a fitting.
 - Higher levels of torque may distort the sprinkler inlet with consequent leakage or impairment of the sprinkler.
- D. Clean the contact surfaces of the dry sprinkler insulating boot assemblies and the surfaces are recommended to be smooth and flat.
- E. Refer to Figures 1 and 3. Install the dry sprinkler boot assemblies around the dry sprinkler barrel and to the freezer until the seals rest flush against the top of the freezer.
- F. Assemble the rings onto the seals, hold in place, and tighten the screws through the holes provided in the assemblies to secure the insulating ring to the top of the freezer. NOTE: A #29 drill is required for a pilot hole in metallic ceilings.
- G. After installation, the entire sprinkler system must be tested. The test must be conducted to comply with the Installation Standards. Make sure the sprinkler has been properly tightened. If a thread leak occurs, normally the unit must be removed, new pipe-joint compound or tape applied, and then reinstalled. This is due to the fact that when the joint seal is damaged, the sealing compound or tape is washed out of the joint. Air testing the sprinkler piping prior to testing with water may be considered in areas where leakage during testing must be prevented. Refer to the appropriate technical data and the AHJ prior to air testing the sprinkler piping. Immediately replace any damaged units, using the designated wrench only.
- H. **After installation and testing and repairing of all leaks, remove the protective shields from the sprinklers by hand. Do NOT use any type of tool to remove the shield. When removing shields, use care to prevent damaging sprinkler fusible element. THE SHIELDS MUST BE REMOVED FROM SPRINKLERS BEFORE PLACING THE SYSTEM IN SERVICE!**
- I. System design must be based on ESFR design guidelines described in the latest National Fire Protection Association standards, FM loss prevention data sheets, and the Authorities Having Jurisdiction. All requirements of recognized ESFR storage sprinkler system design standards apply to systems utilizing Viking ESFR Dry Pendent Sprinklers.

5. OPERATION

During fire conditions, the heat-sensitive fusible element assembly disengages, releasing the internal parts to open the waterway. Water flowing through the sprinkler orifice strikes the sprinkler deflector, forming a uniform spray pattern to suppress the fire.



TECHNICAL DATA

ESFR DRY PENDENT
SPRINKLER VK502 (K14.0)

The Viking Corporation, 210 N Industrial Park Drive, Hastings MI 49058

Telephone: 269-945-9501 Technical Services: 877-384-5464 Fax: 269-818-1680 Email: techsvcs@vikingcorp.com

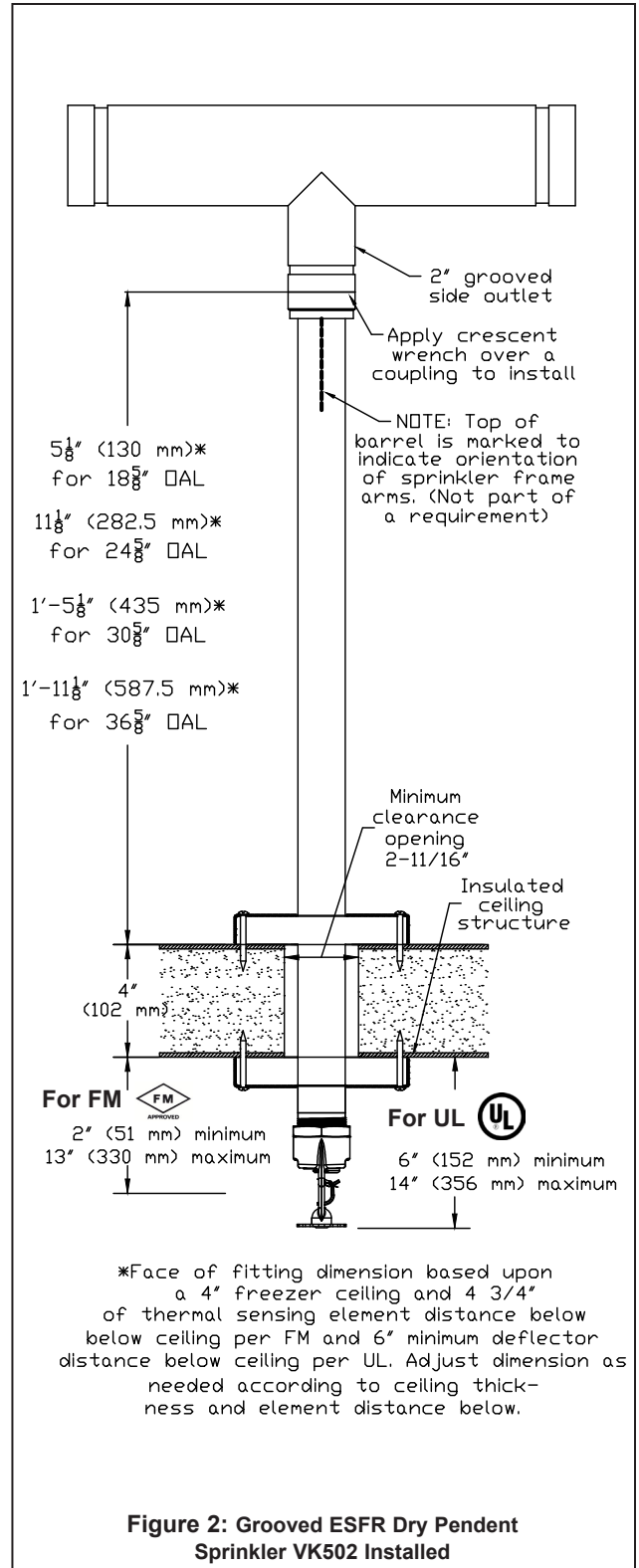
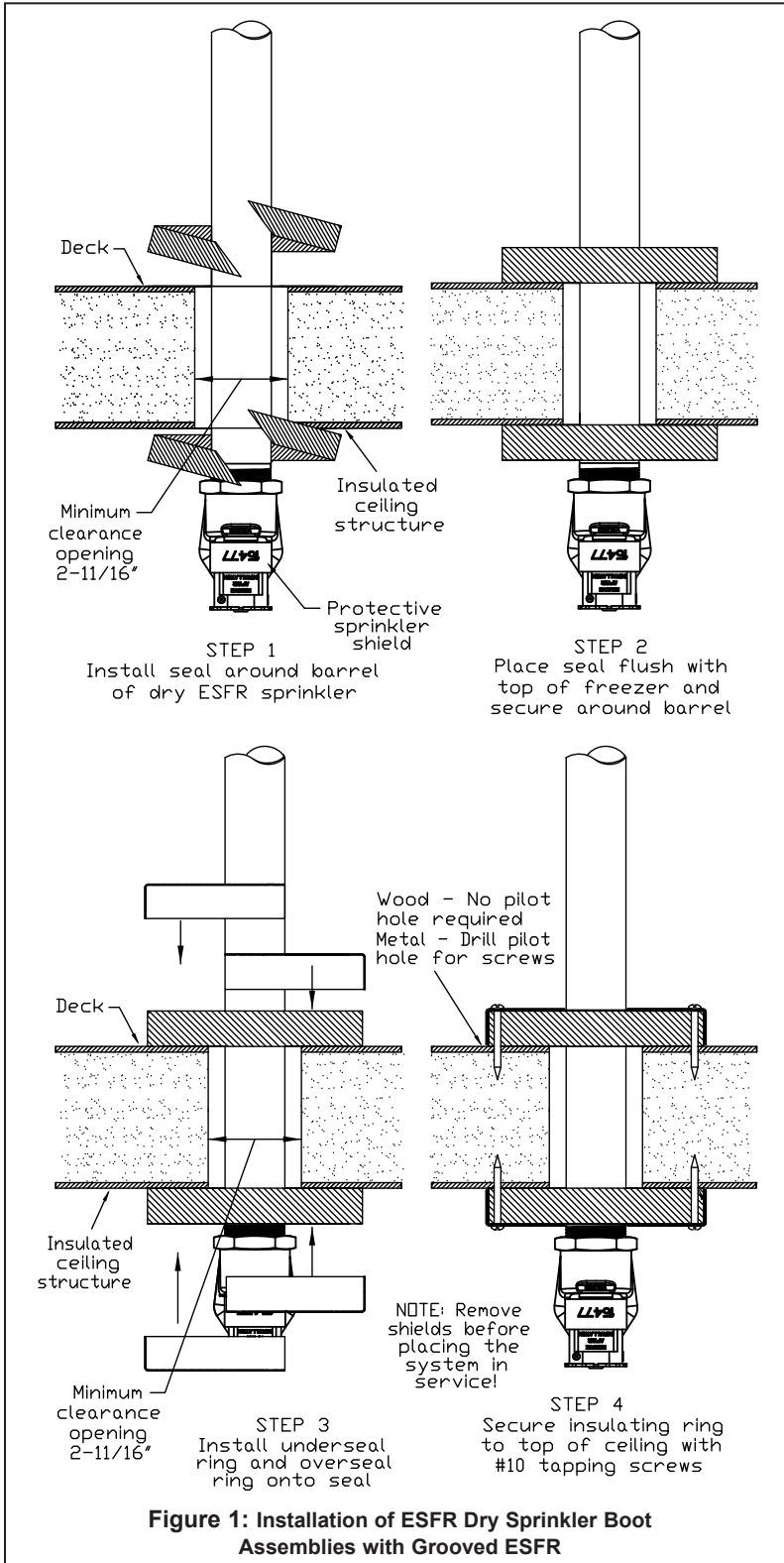



TECHNICAL DATA

**ESFR DRY PENDENT
SPRINKLER VK502 (K14.0)**

The Viking Corporation, 210 N Industrial Park Drive, Hastings MI 49058

Telephone: 269-945-9501 Technical Services: 877-384-5464 Fax: 269-818-1680 Email: techsvcs@vikingcorp.com

6. INSPECTIONS, TESTS AND MAINTENANCE

NOTICE: The owner is responsible for maintaining the fire protection system and devices in proper operating condition. For minimum maintenance and inspection requirements, refer to the NFPA standard that describes care and maintenance of sprinkler systems. In addition, the Authorities Having Jurisdiction may have additional maintenance, testing, and inspection requirements that must be followed.

- A. The sprinklers must be inspected on a regular basis for corrosion, mechanical damage, obstructions, paint, etc. The frequency of inspections may vary due to corrosive atmosphere, water supplies, and activity around the device.
- B. Sprinklers that have been painted or mechanically damaged must be replaced immediately. Sprinklers showing signs of corrosion shall be tested and/or replaced immediately as required. Installation standards require sprinklers to be tested and, if necessary, replaced after a specified term of service. For Viking ESFR Dry Pendent Sprinklers, refer to the Installation Standards (e.g., NFPA 25) and the Authorities Having Jurisdiction for the specified period of time after which testing and/or replacement is required. Sprinklers that have operated cannot be reassembled or reused, but must be replaced. When replacing sprinklers, use only new sprinklers.
- C. The sprinkler discharge pattern is critical for proper fire protection. Therefore, nothing should be hung from, attached to, or otherwise obstruct the discharge pattern. All obstructions must be immediately removed or, if necessary, additional sprinklers installed.
- D. When replacing existing sprinklers, the system must be removed from service. Refer to the appropriate system description and/or valve instructions. Prior to removing the system from service, notify all Authorities Having Jurisdiction. Consideration should be given to employment of a fire patrol in the affected area.
 - 1. Remove the system from service, drain all water, and relieve all pressure on the piping.
 - 2. Remove the ESFR dry sprinkler insulating boot assemblies.
 - 3. Using the designated wrench, remove the old sprinkler and install the new unit. Care must be taken to ensure that the replacement sprinkler is the proper model and style, with the correct orifice size, temperature rating, and response characteristics.
 - 4. Install new ESFR dry sprinkler boot assemblies.
 - 5. Place the system back in service and secure all valves. Check the replaced sprinklers and repair all leaks.
- E. Sprinkler systems that have been subject to a fire must be returned to service as soon as possible. The entire system must be inspected for damage and repaired or replaced as necessary. Sprinklers that have been exposed to corrosive products of combustion, but have not operated, should be replaced. Refer to the Authorities Having Jurisdiction for minimum replacement requirements.

7. AVAILABILITY

The Viking Model VK502 Sprinkler is available through a network of domestic and international distributors. See The Viking Corporation web site for the closest distributor or contact The Viking Corporation.

8. GUARANTEE

For details of warranty, refer to Viking's current list price schedule or contact Viking directly.

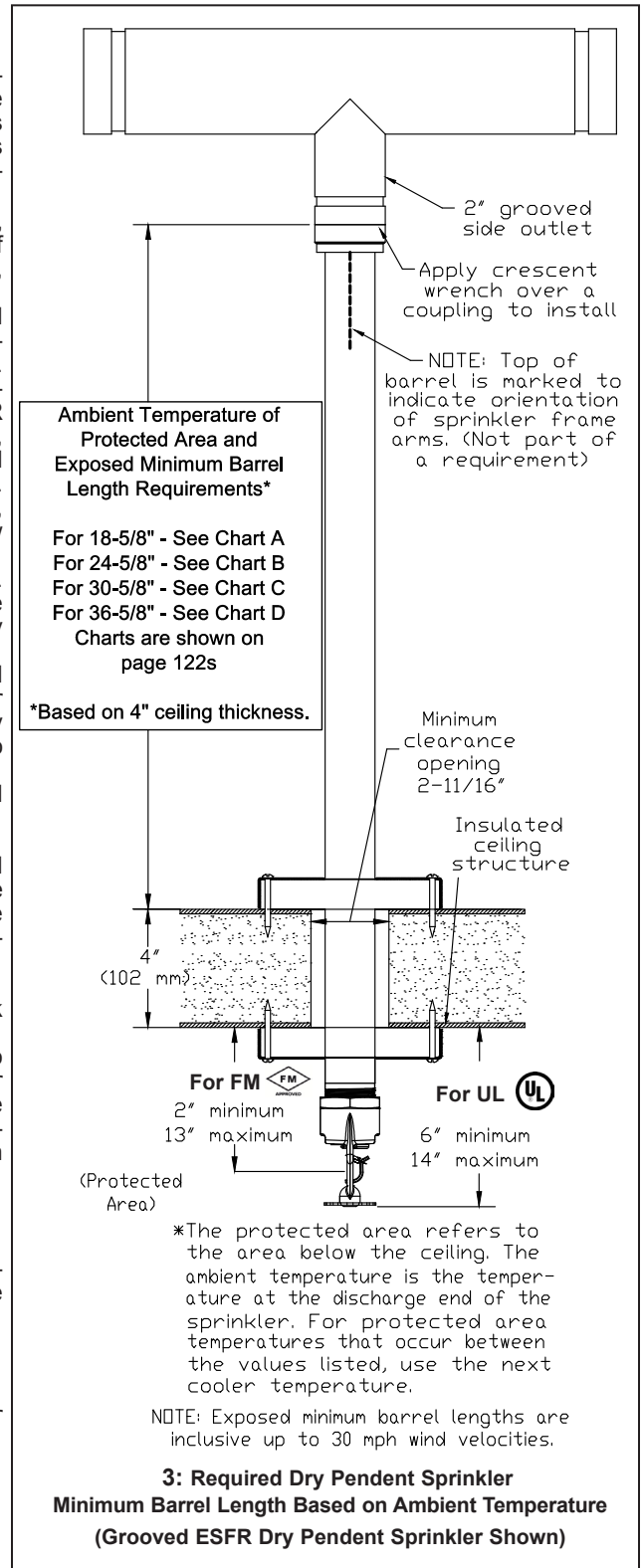



TECHNICAL DATA

ESFR DRY PENDENT
SPRINKLER VK502 (K14.0)

The Viking Corporation, 210 N Industrial Park Drive, Hastings MI 49058
 Telephone: 269-945-9501 Technical Services: 877-384-5464 Fax: 269-818-1680 Email: techsvcs@vikingcorp.com

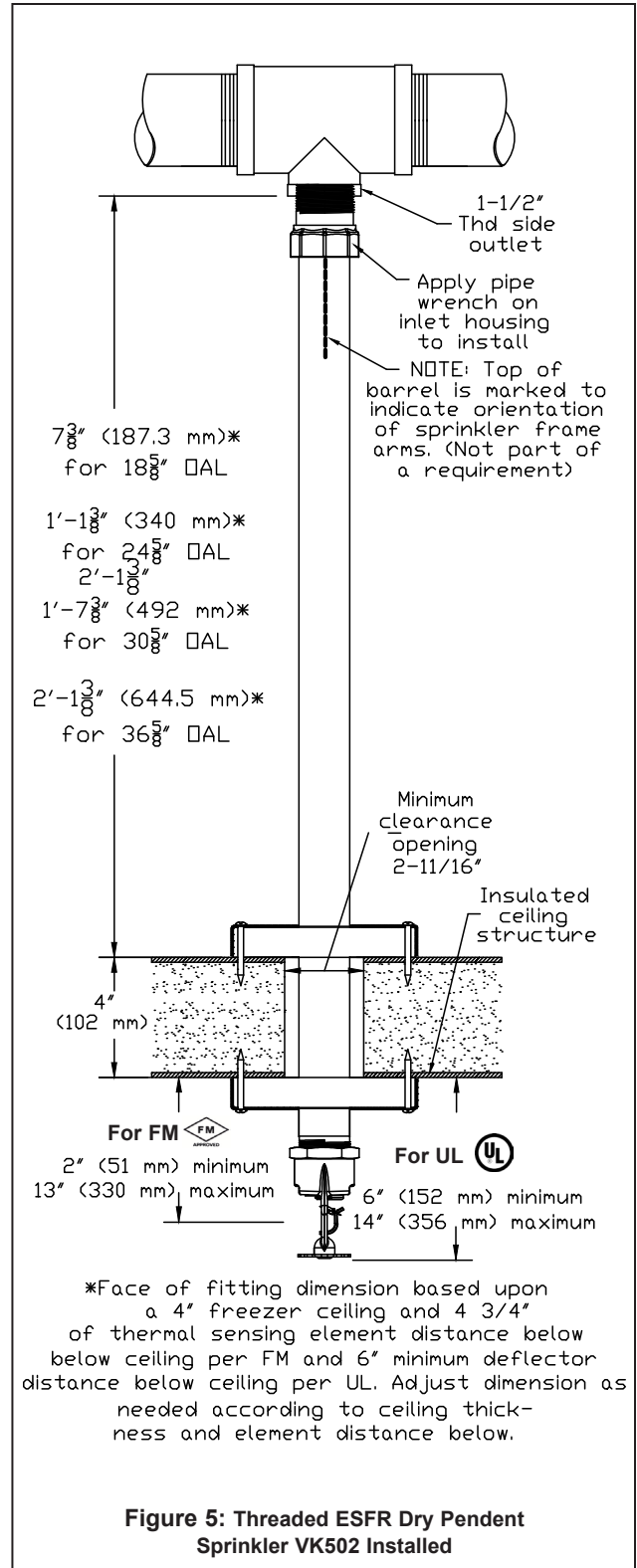
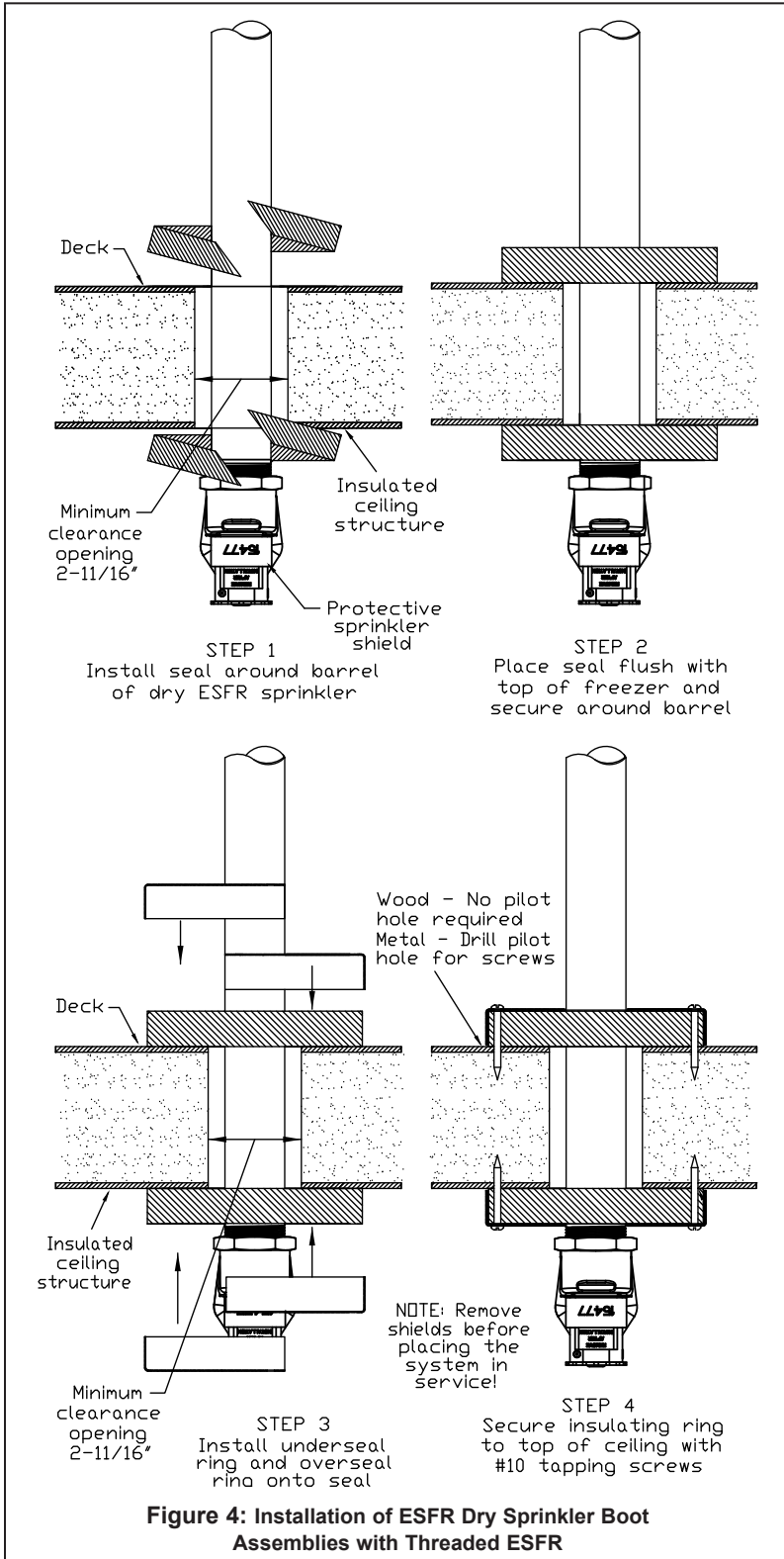



TECHNICAL DATA

**ESFR DRY PENDENT
SPRINKLER VK502 (K14.0)**

The Viking Corporation, 210 N Industrial Park Drive, Hastings MI 49058
 Telephone: 269-945-9501 Technical Services: 877-384-5464 Fax: 269-818-1680 Email: techsvcs@vikingcorp.com

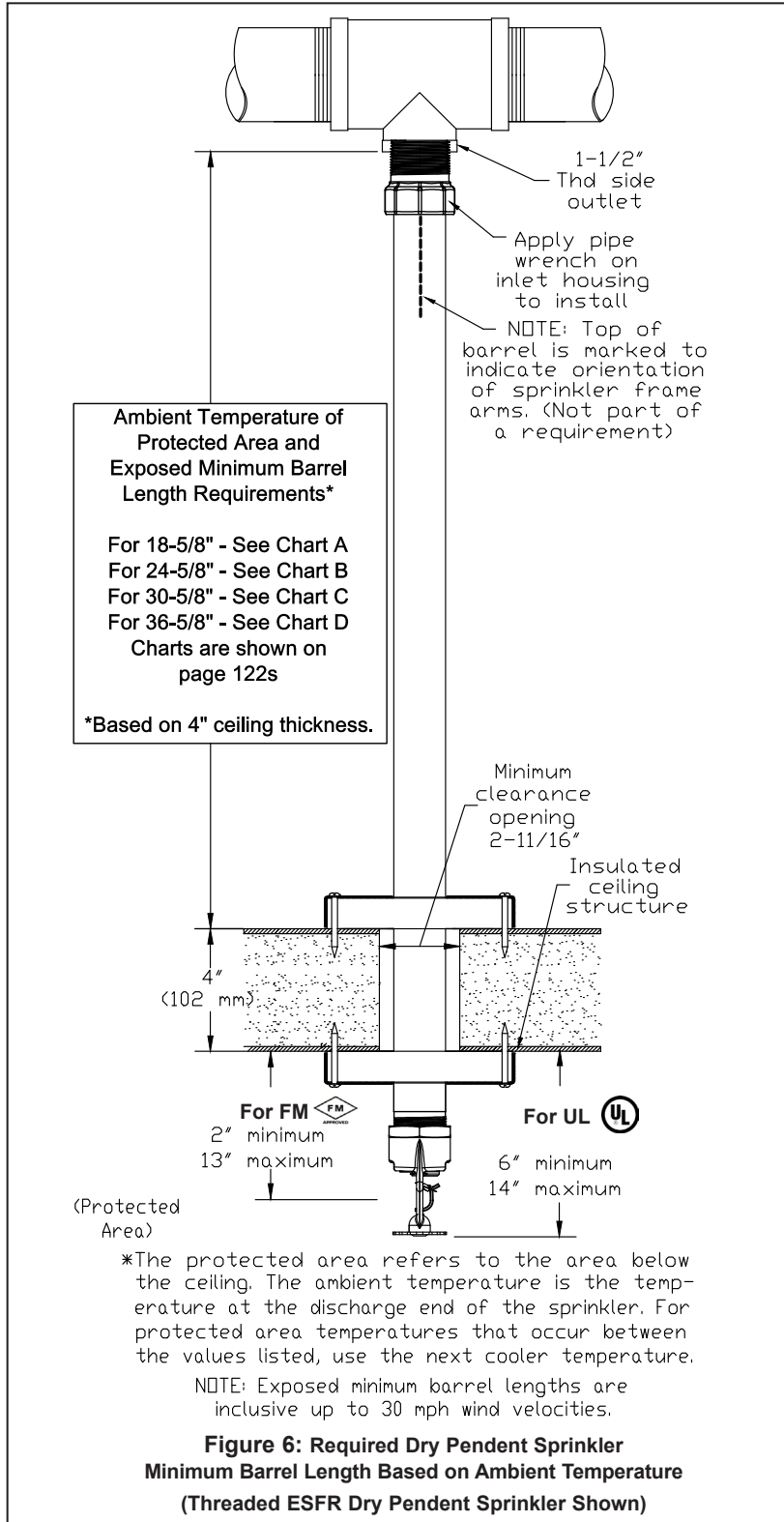

	TECHNICAL DATA	ESFR DRY PENDENT SPRINKLER VK502 (K14.0)
---	-----------------------	---

The Viking Corporation, 210 N Industrial Park Drive, Hastings MI 49058
 Telephone: 269-945-9501 Technical Services: 877-384-5464 Fax: 269-818-1680 Email: techsvcs@vikingcorp.com

INSTALLATION CHARTS FOR MAXIMUM DEFLECTOR CLEARANCE

Chart A - 18-5/8" ESFR Dry Pendant

Ambient Temperature of the Protected Area* at the Discharge End of the Sprinkler	Exposed Barrel Ambient Temp.		
	40°F (4°C)	50°F (10°C)	60°F (16°C)
	Exposed Minimum Barrel Length Face of Tee to Top of Ceiling		
	In. (mm)	In. (mm)	In. (mm)
40°F (4°C)	0	0	0
30°F (-1°C)	0	0	0
Less than 30°F (-1°C)	*Not Applicable		

Chart B - 24-5/8" ESFR Dry Pendant

Ambient Temperature of the Protected Area* at the Discharge End of the Sprinkler	Exposed Barrel Ambient Temp.		
	40°F (4°C)	50°F (10°C)	60°F (16°C)
	Exposed Minimum Barrel Length Face of Tee to Top of Ceiling		
	In. (mm)	In. (mm)	In. (mm)
40°F (4°C)	0	0	0
30°F (-1°C)	0	0	0
20°F (-7°C)	4(100)	0	0
Less than 20°F (-7°C)	*Not Applicable		

Chart C - 30-5/8" ESFR Dry Pendant

Ambient Temperature of the Protected Area* at the Discharge End of the Sprinkler	Exposed Barrel Ambient Temp.		
	40°F (4°C)	50°F (10°C)	60°F (16°C)
	Exposed Minimum Barrel Length Face of Tee to Top of Ceiling		
	In. (mm)	In. (mm)	In. (mm)
40°F (4°C)	0	0	0
30°F (-1°C)	0	0	0
20°F (-7°C)	4(100)	0	0
10°F (-12°C)	8(203)	1(25.4)	0
0°F (-18°C)	12(305)	3(76)	0
Less than 0°F (-18°C)	*Not Applicable		

Chart D - 36-5/8" ESFR Dry Pendant

Ambient Temperature of the Protected Area* at the Discharge End of the Sprinkler	Exposed Barrel Ambient Temp.		
	40°F (4°C)	50°F (10°C)	60°F (16°C)
	Exposed Minimum Barrel Length Face of Tee to Top of Ceiling		
	In. (mm)	In. (mm)	In. (mm)
40°F (4°C)	0	0	0
30°F (-1°C)	0	0	0
20°F (-7°C)	4(100)	0	0
10°F (-12°C)	8(203)	1(25.4)	0
0°F (-18°C)	12(305)	3(76)	0
-10°F (-23°C)	14(356)	4(100)	1(25.4)
-20°F (-29°C)	14(356)	6(152)	3(76)
-30°F (-34°C)	16(406)	8(203)	4(102)
-40°F (-40°C)	18(457)	8(203)	4(102)
Less than -40°F (-40°C)	*Not Applicable		