



TECHNICAL DATA

STANDARD RESPONSE HIGH CHALLENGE® UPRIGHT LARGE DROP SPRINKLER (CONTROL MODE SPECIFIC APPLICATION)

The Viking Corporation, 210 N Industrial Park Drive, Hastings MI 49058

Telephone: 269-945-9501 Technical Services: 877-384-5464 Fax: 269-818-1680 Email: techsvcs@vikingcorp.com

1. DESCRIPTION

The Viking Standard Response High Challenge® Upright Large-Drop Sprinkler VK540 is a thermosensitive, glass-bulb sprinkler intended for use in protecting high piled storage occupancies in accordance with NFPA 13 rules for Large Drop Sprinklers and FM Global criteria for non-storage and storage sprinklers.

The sprinkler produces large water droplets through the use of an extra-large orifice and a special double deflector. The large water droplets provide the required mass to penetrate the fire plume of severe fires. This characteristic permits direct wetting of the burning fuel while cooling the atmosphere and can eliminate the requirement for in-rack sprinklers in certain cases.

Viking VK540 Upright Large Drop Sprinklers are primarily intended to protect the following types of storage, which tend to produce severe-challenge fires: palletized and solid pile storage and single, double, multiple row, and portable open rack storage (no open-top containers or solid shelves).

Viking High Challenge® Upright Large-Drop Sprinkler VK540 provides protection of most common storage materials, including:

- Class I, II, III, and IV commodities*.
- Cartoned or exposed unexpanded plastics*.
- Cartoned or exposed expanded plastics*.

* Refer the Approval Charts and Design Criteria on pages 113c-e for cULus Listing and FM Approval requirements that must be followed.

In addition, some storage arrangements of idle wood pallets, rolled paper, aerosols, and rubber tires may be protected by Viking Upright Large Drop Sprinkler VK540.

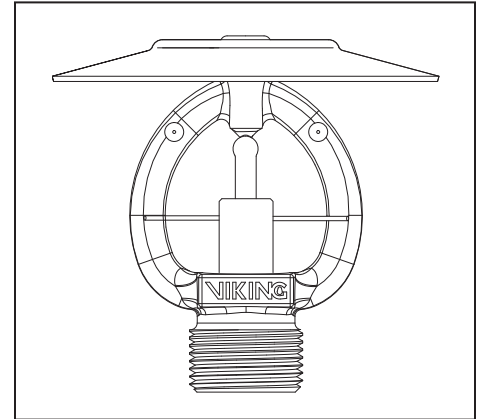

2. LISTINGS AND APPROVALS



cULus Listed: Category VNIV



FM Approved: Class 2007

NYC Approved: MEA 89-92-E, Volume 19

NOTE: Other International approval certificates are available upon request.

Refer to Approval Chart 1 and Design Criteria on pages 113c-d for cULus Listing requirements, and refer to Approval Chart 2 and Design Criteria on page 113e for FM Approval requirements that must be followed.

3. TECHNICAL DATA

Specifications:

Available since 1996.

Minimum Operating Pressure: Refer to Design Criteria on pages 113c-d.

Rated to 175 psi (12 bar) water working pressure. Factory tested hydrostatically to 500 psi (34.5 bar).

Thread size: 1/2" (15 mm) NPT or 3/4" (20 mm) NPT

Nominal K-Factor: 11.2 U.S. (161.3 metric*)

* Metric K-factor measurement shown is when pressure is measured in Bar. When pressure is measured in kPa, divide the metric K-factor shown by 10.0.

Glass-bulb fluid temperature rated to -65 °F (-55 °C)

Overall Length: 3-5/16" (84 mm)

Deflector Diameter: 3-5/8" (92 mm)

Deflector: U.S.A. Patent No. 1,118,710

Material Standards:

Frame Casting: Brass UNS-C84400

Screw: Brass UNS-C36000

Pip Cap: Leaded Bronze UNS-C31600 or UNS-C31400

Belleville Spring Sealing Assembly: Nickel Alloy, coated on both sides with Teflon Tape

Deflector: Brass UNS-C26000

Ejector Spring: 17-7 Stainless Steel

Bulb: Glass, nominal 5 mm diameter

Viking Technical Data may be found on
The Viking Corporation's Web site at
<http://www.vikinggroupinc.com>.
The Web site may include a more recent
edition of this Technical Data Page.

	<h2 style="margin: 0;">TECHNICAL DATA</h2>	<p>STANDARD RESPONSE HIGH CHALLENGE® UPRIGHT LARGE DROP SPRINKLER (CONTROL MODE SPECIFIC APPLICATION)</p>
---	--	--

The Viking Corporation, 210 N Industrial Park Drive, Hastings MI 49058

Telephone: 269-945-9501 Technical Services: 877-384-5464 Fax: 269-818-1680 Email: techsvcs@vikingcorp.com

Ordering Information: (Also refer to the current Viking price list.)

Order Standard Response High Challenge® Upright Large-Drop Sprinkler VK540 by first adding the appropriate suffix for the sprinkler finish and then the appropriate suffix for the temperature rating to the sprinkler base part number.

Finish Suffix: Brass = A

Temperature Suffix: 155 °F (68 °C) = B, 200 °F (93 °C) = E, and 286 °F (141 °C) = G

For example, sprinkler VK540 with a 3/4" thread, a Brass finish, and a 155 °F (68 °C) temperature rating = Part No. 13167AB.

Available Finishes And Temperature Ratings: Refer to Table 1.

Accessories: (Also refer to the "Sprinkler Accessories" section of the Viking data book.)

Sprinkler Wrench:

Part No. 05118CW/B, fits both 1/2" NPT and 3/4" NPT Sprinklers (available since 1981)

Sprinkler Cabinet:

Six-head capacity: Part No. 03985A (available since 1977)

TABLE 1: AVAILABLE SPRINKLER TEMPERATURE RATINGS AND FINISHES

Sprinkler Temperature Classification	Sprinkler Nominal Temperature Rating ¹	Maximum Ambient Ceiling Temperature ²	Frame Paint Color	Bulb Color
Ordinary	155 °F (68 °C)	100 °F (38 °C)	None	Red
Intermediate	200 °F (93 °C)	150 °F (65 °C)	White	Green
High	286 °F (141 °C)	225 °F (107 °C)	Blue	Blue

Sprinkler Finish: Brass

Footnotes

¹ The sprinkler temperature rating is stamped on the deflector.

² Based on NFPA-13. Other limits may apply, depending on fire loading, sprinkler location, and other requirements of the Authority Having Jurisdiction. Refer to specific installation standards.

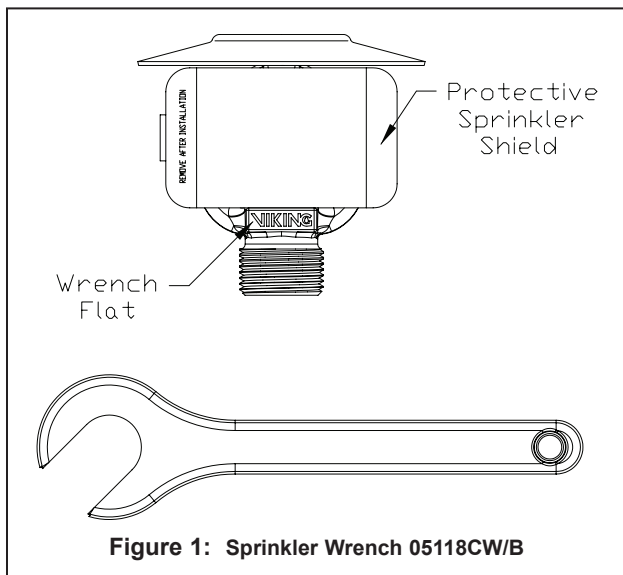

Figure 1: Sprinkler Wrench 05118CW/B

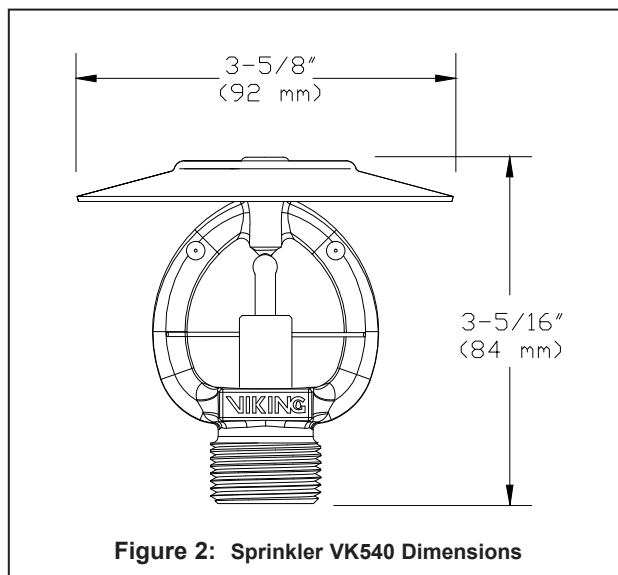



Figure 2: Sprinkler VK540 Dimensions

	<h2 style="margin: 0;">TECHNICAL DATA</h2>	<p>STANDARD RESPONSE HIGH CHALLENGE® UPRIGHT LARGE DROP SPRINKLER (CONTROL MODE SPECIFIC APPLICATION)</p>
---	--	--

The Viking Corporation, 210 N Industrial Park Drive, Hastings MI 49058
Telephone: 269-945-9501 Technical Services: 877-384-5464 Fax: 269-818-1680 Email: techsvcs@vikingcorp.com

Approval Chart 1 (UL) Standard Response High Challenge® Upright Large Drop Sprinklers (Control Mode Specific Application) Maximum 175 PSI (12 bar) WWP													
Base Part Number ¹	SIN	NPT Thread Size		Nominal K-Factor		Overall Length		Listings and Approvals ³ (Refer also to Design Criteria on page 113d.)					
		Inches	mm	U.S.	metric ²	Inches	mm	cULus ⁴	NYC ⁵	VdS	LPCB	CE	
13166	VK540	1/2"	15 mm	11.2	161.3	2-5/16	84	A1 ⁶	A1 ⁶	--	--	--	--
13167	VK540	3/4"	20 mm	11.2	161.3	2-5/16	84	A1	A1	--	--	--	--
Approved Temperature Ratings A - 155 °F (68 °C), 200 °F (93 °C) and 286 °F (141 °C)							Approved Finish 1 - Brass						
Footnotes													
¹ Base part number shown. For complete part number, refer to the price list.													
² Metric K-factor shown is for use when pressure is measured in bar. When pressure is measured in kPa, divide the metric K-factor shown by 10.0.													
³ This chart shows listings and approvals available at the time of printing. Other approvals may be in process.													
⁴ Listed by Underwriters Laboratories Inc. for use in the U.S. and Canada.													
⁵ Accepted for use, City of New York Department of Buildings, MEA 89-92-E, Vol. 19.													
⁶ The 1/2" NPT Extra-Large Orifice Sprinkler is Listed and Approved for retrofit use only.													

4. INSTALLATION

WARNING: Viking sprinklers are manufactured and tested to meet rigid requirements of the approving agency. The sprinklers are designed to be installed in accordance with recognized installation standards. Viking High Challenge® Sprinkler VK540 must be installed in accordance with NFPA 13 Large Drop Sprinkler rules and FM Global criteria for Control Mode Specific Application (CMSA) and Large Drop Sprinklers. Deviation from the standards or any alteration to the sprinkler after it leaves the factory including, but not limited to: painting, plating, coating, or modification, may render the sprinkler inoperative and will automatically nullify the approval and any guarantee made by The Viking Corporation.

- A. Sprinklers must be handled with care. They must be stored in a cool, dry place in their original shipping container. Never install sprinklers that have been dropped or damaged in any way or exposed to temperatures exceeding the maximum ambient temperature allowed (refer to Table 1). Never install any glass-bulb sprinkler if the bulb is cracked or if there is a loss of liquid from the bulb. A small air bubble should be present in the glass bulb. Any sprinkler with a loss of liquid from the glass bulb should be destroyed immediately.
- B. Wet pipe systems must be provided with adequate heat. Sprinklers supplied from dry systems in areas subject to freezing must be listed dry sprinklers, or upright or horizontal sidewall sprinklers installed so that water is not trapped.
- C. Use care when locating sprinklers near fixtures that can generate heat. DO NOT install sprinklers where they could be exposed to temperatures exceeding the maximum recommended ambient temperature for the temperature rating used.
- D. The sprinklers must be installed after the piping is in place to prevent mechanical damage. Before installing, be sure to have the appropriate sprinkler model and style, with the correct orifice size, temperature rating, and response characteristics.
- E. With the sprinkler contained in the plastic protective shield, apply a small amount of pipe-joint compound or tape to the male threads only, while taking care not to allow a build-up of compound in the sprinkler orifice.
- F. Install the sprinkler on the piping using special sprinkler wrench 05118CW/B only, while taking care not to damage the sprinkler operating parts. (Any other type of wrench may damage the unit.) DO NOT use the sprinkler deflector to start or thread the sprinkler into a fitting.
- G. After installation, the entire sprinkler system must be tested. The test must be conducted to comply with the Installation Standards. Make sure the sprinkler has been properly tightened. If a thread leak occurs, normally the unit must be removed, new pipe-joint compound or tape applied, and then reinstalled. This is due to the fact that when the joint seal is damaged, the sealing compound or tape is washed out of the joint. Immediately replace any damaged units, using the special sprinkler wrench only.



TECHNICAL DATA

STANDARD RESPONSE HIGH CHALLENGE® UPRIGHT LARGE DROP SPRINKLER (CONTROL MODE SPECIFIC APPLICATION)

The Viking Corporation, 210 N Industrial Park Drive, Hastings MI 49058

Telephone: 269-945-9501 Technical Services: 877-384-5464 Fax: 269-818-1680 Email: techsvcs@vikingcorp.com

DESIGN CRITERIA - UL

(Also refer to Approval Chart 1 on page 113c.)

General Guidelines:

Maximum Roof or Ceiling Slope: 2 in 12 (167 mm/m or 9.5 degrees).

Sprinkler Position: Approved for use only in the upright position. Align the deflector parallel with the ceiling or roof.

System Type: Wet systems, dry systems, or preaction systems.

NOTE: The use of internally galvanized steel pipe or copper pipe for dry systems and preaction systems using Large Drop Sprinklers is required by some Installation Standards.

Deflector Distance from Walls: At least 4" (102 mm) from walls, and no more than one-half the allowable distance permitted between sprinklers.

Clearance from Deflector to Top of Storage: At least 36" (914 mm).

Minimum Area of Coverage Allowed per Sprinkler: 80 ft² (7.4 m²).

Minimum Distance Between Sprinklers: 8 ft. (2.4 m).

Hydraulic Calculation Note: To determine the number of sprinklers to calculate per branch line:

- Determine sprinkler spacing. (Refer to the appropriate Installation Standard and the Authority Having Jurisdiction.)
- Determine size of the remote area by multiplying the area of coverage per sprinkler by the number of sprinklers to be calculated (refer to the appropriate Installation Standard and the Authority Having Jurisdiction).
- Multiply the square root of the remote area determined in the step above by at least 1.2 and divide the product by the distance between sprinklers on the branch lines. The quotient determines the number of sprinklers to calculate per branch line. Any fractional sprinkler shall be carried to the next higher whole sprinkler.

NOTE: If the ceiling is beam and girder or panel construction, locate sprinklers in the bays rather than under the beams.

cULus Listing Requirements:

Standard Response High Challenge® Upright Large-Drop Sprinkler VK540 is cULus Listed as indicated in Approval Chart 1 for installation in accordance with the latest appropriate NFPA standards (including NFPA 13) for Large Drop Sprinklers.

Deflector Position:

- **Under Unobstructed Construction:** Position the deflector between 6" and 8" (152 mm to 203 mm) below the ceiling.
- **Under Obstructed Construction,** locate in accordance with one of the following:
 - 1) Position the deflectors between of 6" and 12" (152 mm to 305 mm) below the ceiling.
 - 2) Install with the deflectors within the horizontal planes 1" to 6" (25.4 mm to 152 mm) below wood joist or composite wood joist construction, to a maximum distance of 22" (559 mm) below the ceiling/roof or deck.
 - 3) Install with the deflectors of sprinklers under concrete tee construction with stems spaces less than 7-1/2 ft. (2.3 m) but more than 3 ft. (0.9 m) on centers, regardless of the depth of the tee, located at or above a horizontal plane 1" (25.4 mm) below the bottom of the stems of the tees and shall comply with the obstruction rules in NFPA 13 for avoiding obstructions to discharge (Table 8.11.5.1.2 in the 2010 edition of NFPA 13).

Maximum Distance Between Sprinklers:

- Under unobstructed and obstructed noncombustible construction and unobstructed combustible construction, the distance between sprinklers shall be limited to not more than 12 ft. (3.7 m) between sprinklers, with the area of coverage per sprinkler limited to 130 ft² (12.1 m²).
- Under obstructed combustible construction and in rack storage applications, the distance between sprinklers shall be limited to not more than 10 ft. (3.1 m) between sprinklers, with the area of coverage per sprinkler limited to 100 ft² (9.3 m²).

The sprinkler installation and obstruction rules contained in NFPA 13 for Large Drop sprinklers must be followed.

IMPORTANT: Always refer to Bulletin Form No. F_091699 - Care and Handling of Sprinklers. Viking High Challenge® Upright Large-Drop Sprinklers are to be installed in accordance with the latest edition of Viking technical data, the latest standards of NFPA, and any other Authorities Having Jurisdiction, and also with provisions of governmental codes, ordinances, and standards whenever applicable.



TECHNICAL DATA

STANDARD RESPONSE HIGH CHALLENGE® UPRIGHT LARGE DROP SPRINKLER (CONTROL MODE SPECIFIC APPLICATION)

The Viking Corporation, 210 N Industrial Park Drive, Hastings MI 49058

Telephone: 269-945-9501 Technical Services: 877-384-5464 Fax: 269-818-1680 Email: techsvcs@vikingcorp.com

Approval Chart 2 (FM)

Standard Response Upright Sprinkler VK540
Maximum 175 PSI (12 bar) WWP

KEY	
Temperature	→
Finish	→
Escutcheon (if applicable)	→
A1X	←

Base Part Number ¹	SIN	NPT Thread Size		Nominal K-Factor		Overall Length		FM Approvals ^{3,4} (Refer also to Design Criteria below.)	
		Inches	mm	U.S.	metric ²	Inches	mm		
13166	VK540	1/2"	15 mm	11.2	161.3	2-5/16	84	A1 ⁵	
13167	VK540	3/4"	20 mm	11.2	161.3	2-5/16	84	A1	
Approved Temperature Ratings A - 155 °F (68 °C), 200 °F (93 °C) and 286 °F (141 °C)							Approved Finish 1 - Brass		

Footnotes

- ¹ Base part number shown. For complete part number, refer to the price list.
- ² Metric K-factor shown is for use when pressure is measured in bar. When pressure is measured in kPa, divide the metric K-factor shown by 10.0.
- ³ This chart shows the FM Approvals available at the time of printing. Other approvals may be in process.
- ⁴ FM Approved as a standard response upright **Non-Storage** sprinkler and also FM Approved as a standard response upright **Storage** sprinkler. Refer to Design Criteria below.
- ⁵ The 1/2" NPT Extra-Large Orifice Sprinkler is FM Approved for retrofit use only.

DESIGN CRITERIA - FM

(Also refer to Approval Chart 2 above.)

FM Approval Requirements:

- Sprinkler VK540 is FM Approved as a standard response upright **Storage** sprinkler as indicated in the FM Approval Guide.
 - For specific application and installation requirements, reference the latest applicable FM Loss Prevention Data Sheets (including Data Sheets 2-0 and 8-9).
 - Sprinkler VK540 is also FM Approved as a standard response upright **Non-Storage** sprinkler as indicated in the FM Approval Guide.
 - For specific application and installation requirements, reference the latest applicable FM Loss Prevention Data Sheets (including Data Sheet 2-0).
- FM Global Loss Prevention Data Sheets contain guidelines relating to, but not limited to: minimum water supply requirements, hydraulic design, ceiling slope and obstructions, minimum and maximum allowable spacing, and deflector distance below the ceiling.

NOTE: The FM installation guidelines may differ from cULus and/or NFPA criteria.

IMPORTANT: Always refer to Bulletin Form No. F_091699 - Care and Handling of Sprinklers. Viking sprinklers are to be installed in accordance with the latest edition of Viking technical data, the appropriate standards of NFPA, FM Global, and any other Authorities Having Jurisdiction, and also with provisions of governmental codes, ordinances, and standards whenever applicable.

**TECHNICAL DATA****STANDARD RESPONSE HIGH
CHALLENGE® UPRIGHT LARGE
DROP SPRINKLER (CONTROL
MODE SPECIFIC APPLICATION)**

The Viking Corporation, 210 N Industrial Park Drive, Hastings MI 49058

Telephone: 269-945-9501 Technical Services: 877-384-5464 Fax: 269-818-1680 Email: techsvcs@vikingcorp.com

H. After installation and testing and repairing of all leaks, remove the protective shields from the sprinklers. To remove the shield, simply pull the ends of the shield apart where it is snapped together. THE SHIELDS MUST BE REMOVED FROM SPRINKLERS BEFORE PLACING THE SYSTEM IN SERVICE!

5. OPERATION

During fire conditions, the heat-sensitive liquid in the glass bulb expands, causing the glass to shatter, releasing the pip cap and sealing spring assembly. Water flowing through the sprinkler orifice strikes the sprinkler deflector, forming a uniform spray pattern to extinguish or control the fire.

6. INSPECTIONS, TESTS AND MAINTENANCE

NOTICE: The owner is responsible for maintaining the fire protection system and devices in proper operating condition. For minimum maintenance and inspection requirements, refer to the NFPA standard that describes care and maintenance of sprinkler systems. In addition, the Authorities Having Jurisdiction may have additional maintenance, testing, and inspection requirements that must be followed.

- A. The sprinklers must be inspected on a regular basis for corrosion, mechanical damage, obstructions, paint, etc. The frequency of inspections may vary due to corrosive atmosphere, water supplies, and activity around the device.
- B. Sprinklers that have been painted or mechanically damaged must be replaced immediately. Sprinklers showing signs of corrosion shall be tested and/or replaced immediately as required. Installation standards require sprinklers to be tested and, if necessary, replaced after a specified term of service. Refer to the Installation Standards (e.g., NFPA 25) and the Authorities Having Jurisdiction for the specified period of time after which testing and/or replacement is required. Sprinklers that have operated cannot be reassembled or reused, but must be replaced. When replacing sprinklers, use only new sprinklers.
- C. The sprinkler discharge pattern is critical for proper fire protection. Therefore, nothing should be hung from, attached to, or otherwise obstruct the discharge pattern. All obstructions must be immediately removed or, if necessary, additional sprinklers installed.
- D. When replacing existing sprinklers, the system must be removed from service. Refer to the appropriate system description and/or valve instructions. Prior to removing the system from service, notify all Authorities Having Jurisdiction. Consideration should be given to employment of a fire patrol in the affected area.
 1. Remove the system from service, drain all water, and relieve all pressure on the piping.
 2. Using the special sprinkler wrench 05118CW/B, remove the old sprinkler and install the new unit. Care must be taken to ensure that the replacement sprinkler is the proper model and style, with the correct orifice size, temperature rating, and response characteristics. A fully stocked spare sprinkler cabinet should be provided for this purpose.
 3. Place the system back in service and secure all valves. Check the replaced sprinklers and repair all leaks.
- E. Sprinkler systems that have been subject to a fire must be returned to service as soon as possible. The entire system must be inspected for damage and repaired or replaced as necessary. Sprinklers that have been exposed to corrosive products of combustion, but have not operated, should be replaced. Refer to the Authorities Having Jurisdiction for minimum replacement requirements.

7. AVAILABILITY

The Viking Model VK540 Sprinkler is available through a network of domestic and international distributors. See The Viking Corporation web site for the closest distributor or contact The Viking Corporation.

8. GUARANTEE

For details of warranty, refer to Viking's current list price schedule or contact Viking directly.