

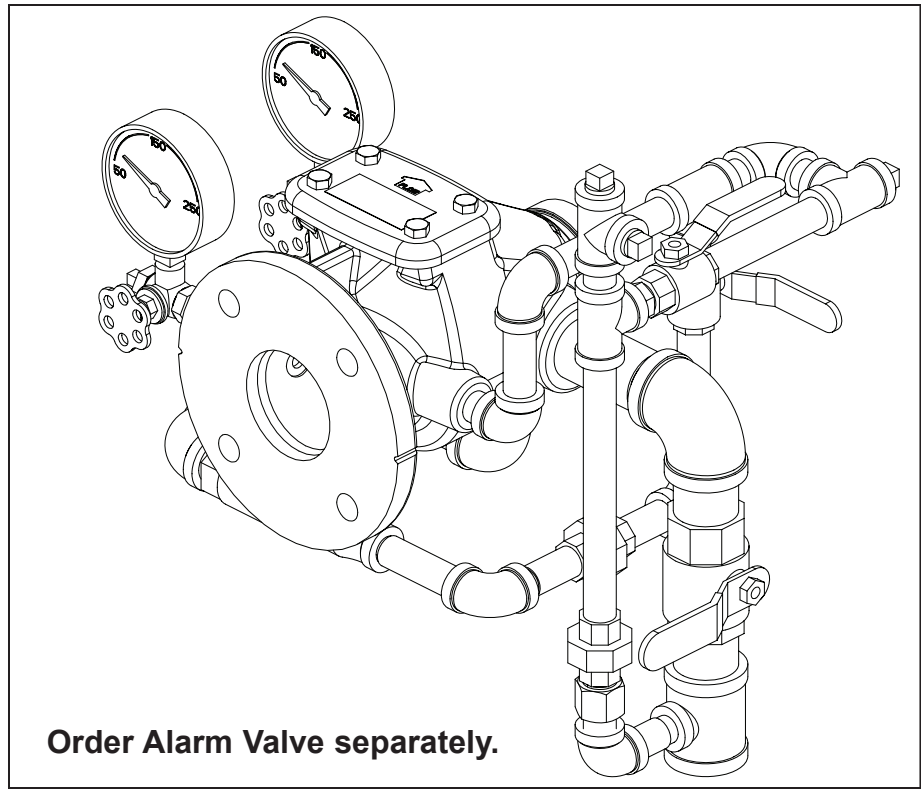

TECHNICAL DATA

MODEL J-1
ALARM CHECK VALVE
HORIZONTAL TRIM



This Trim Chart is for use with the following Viking Trim Sets

Valve Size	Galvanized	Brass
3" (DN80)	08763	11432
4" (DN100)	08765	11433
6" (DN150)	08767	11434
8" (DN200)	08769	11435

NOTES: For use with Trim Chart on page 28 b.

General Notes:

- Valve must be trimmed as shown. Any deviation from trim size or arrangement may affect the proper operation of the valve.
- All pipe, 3/4" (20 mm) and smaller, shall be galvanized steel except when other materials are specified in the technical data for the system used. All trim components must be listed for up to 250 PSI (17.2 bar) Water Working Pressure.
- Dimensions in parentheses are millimeter.
- Viking uses ASME fitting designations. Tee's shall be called out in the following order: 1 - largest outlet on run; 2 - Smaller outlet on run; 3 - Branch size.

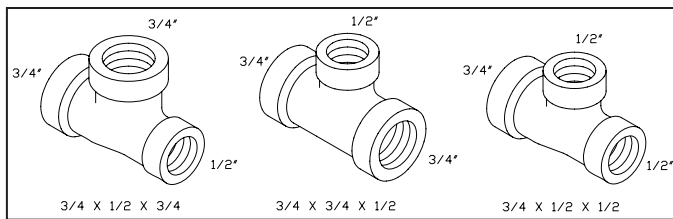

Note 1: When using a water motor alarm, a strainer is required. Circuit closer vent trim may be required when an alarm pressure switch is used. (See technical data for the retard chamber.)

Note 2: This location may be used for optional pressure relief valve (not available from Viking). Install 3/4" (20 mm) tee and listed pressure relief valve.

Note 3: To supply an optional excess pressure pump (not available from Viking and not a listed assembly), replace 1/2" ell marked "A" with a tee. Replace 3/4" ell marked "B" with a tee to connect outlet from excess pressure pump. Do not exceed listed water working pressure rating of system components. Perform hydrostatic tests in accordance with recognized Installation Standards.

Note 4: Location for non-interruptible pressure switch. When waterflow through the alarm valve occurs, supply to this location cannot be shut off until water flow through the alarm valve stops. **Caution** - Non-interruptible alarm port may only be used on systems with constant pressure. A retard chamber may not be installed on the non-interruptible alarm port.

Note 5: Component specified is included in Viking trim sets; do not substitute. Use of components other than specified will void any listings and approvals and may affect operation of the valve.

Note 6: 300 PSI (20.7 bar) water pressure gauges are provided with trim. 600 PSI (41.4 bar) water pressure gauges are available. Order separately when needed*. Refer to current Viking Price Book.

* NFPA 13 requires gauges to have a minimum limit not less than twice the normal water working pressure at the point where the gauges are installed. When normal water working pressure exceeds 150 PSI (10.3 bar), order 600 PSI (41.4 bar) water pressure gauges separately.



TECHNICAL DATA

MODEL J-1 ALARM CHECK VALVE HORIZONTAL TRIM

Available since 1997

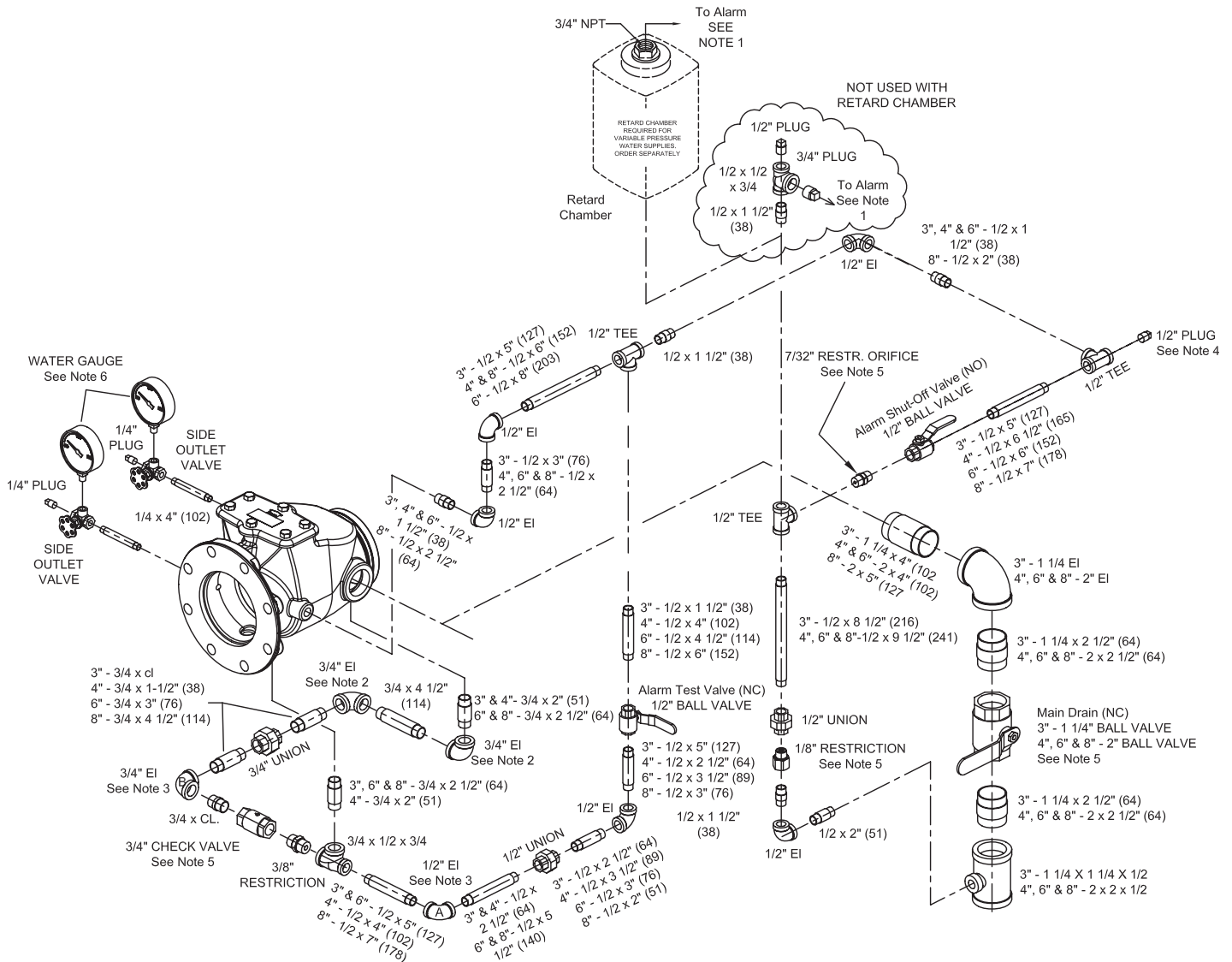

**Order Alarm Valve separately.
Refer to page 28a for Notes**



TECHNICAL DATA

**MODEL J-1
ALARM CHECK VALVE
HORIZONTAL TRIM**

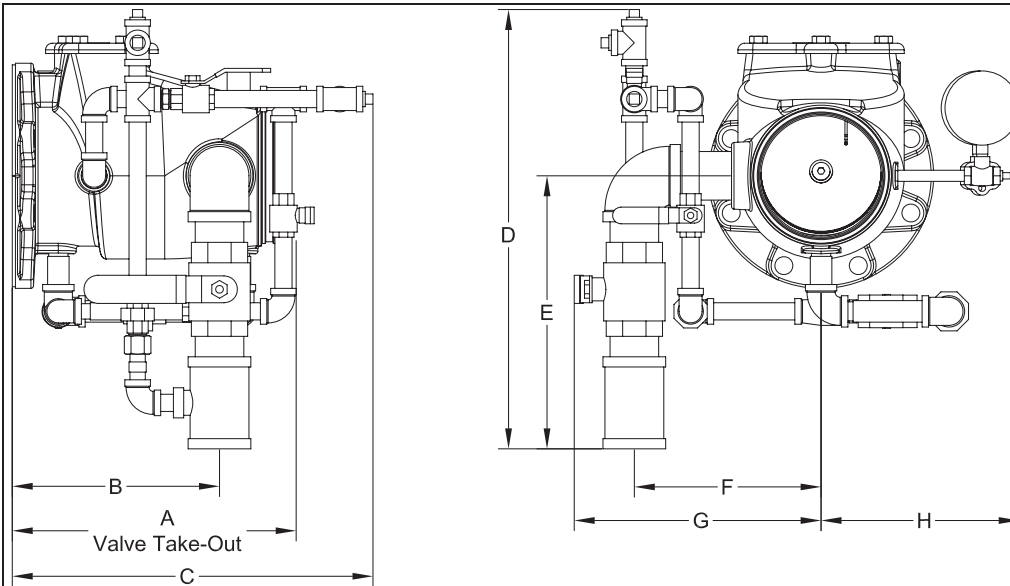

**Figure 2 -
Dimensions
for Constant
Pressure Water
Supply**

Size	A	B	C	D	E	F	G	H
3" (DN80)	10-3/16" (259)	7-1/4" (184)	13-15/16" (354)	18-11/16" (475)	10-1/16" (256)	7-3/4" (197)	9-7/8" (251)	8-5/16" (211)
4" (DN100)	10-5/8" (270)	7-3/8" (187)	15" (381)	21-1/2" (545)	13-3/8" (339)	8-3/8" (213)	9-15/16" (252)	8-11/16" (221)
6" (DN150)	13-3/8" (340)	10-1/8" (257)	17-5/8" (448)	21-1/2" (545)	13-3/8" (339)	9-1/8" (232)	12-1/16" (306)	9-11/16" (246)
8" (DN200)	17" (432)	8-5/16" (210)	17" (432)	21-1/2" (545)	13-3/8" (339)	11-1/2" (292)	14-7/16" (367)	10-11/16" (271)

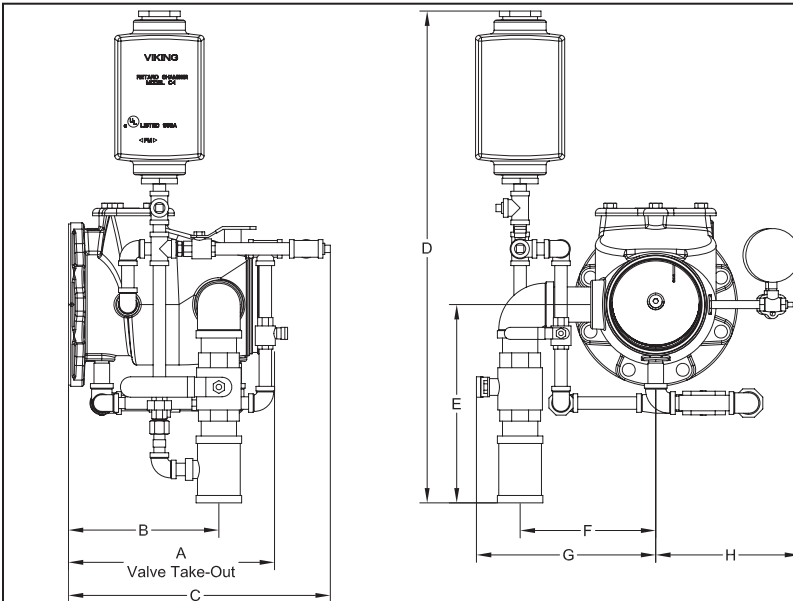

**Figure 3 -
Dimensions
for Variable
Pressure Water
Supply**

Size	A	B	C	D	E	F	G	H
3" (DN80)	10-3/16" (259)	7-1/4" (184)	13-15/16" (354)	27-5/16" (694)	10-1/16" (256)	7-3/4" (197)	9-7/8" (251)	8-5/16" (211)
4" (DN100)	10-5/8" (270)	7-3/8" (187)	15" (381)	31-3/8" (796)	13-3/8" (339)	8-3/8" (213)	9-15/16" (252)	8-11/16" (221)
6" (DN150)	13-3/8" (340)	10-1/8" (257)	17-5/8" (448)	31-3/8" (796)	13-3/8" (339)	9-1/8" (232)	12-1/16" (306)	9-11/16" (246)
8" (DN200)	17" (432)	8-5/16" (210)	17" (432)	31-3/8" (796)	13-3/8" (339)	11-1/2" (292)	14-7/16" (367)	10-11/16" (271)

**THIS PAGE
INTENTIONALLY
LEFT BLANK**