



REPLACEMENT PARTS

**DELUGE VALVE HALAR®
COATED MODEL F-2
1-1/2" & 2" (DN40 & DN50)**

Manufactured 2004 -

Valve Take-out

12-15/64" (310.7 mm)

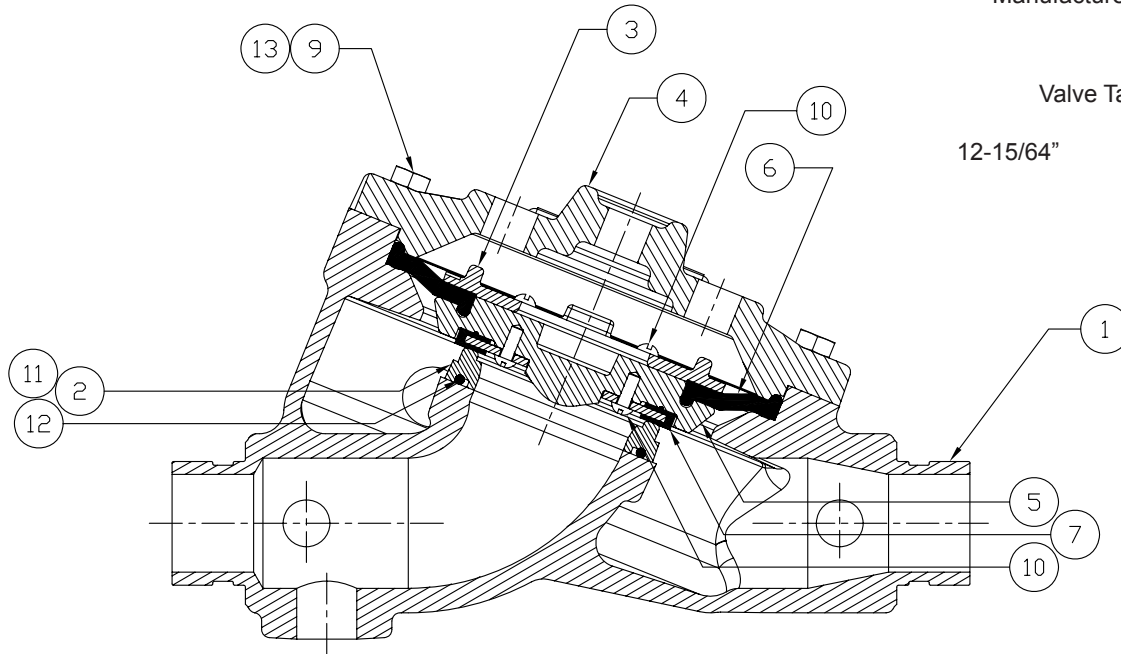

ITEM NO.	PART NUMBER	DESCRIPTION	MATERIAL	NO. REQ'D
	1-1/2" & 2" (DN40 & DN50)			1-1/2" & 2" (DN40 & DN50)
1	--	Body	Ductile Iron 65-45-12, Halar® Coated	1
2	*	Seat	Brass UNS-C84400, Nickel Plated	1
3	04224BN	Ring Clamp, Upper Diaphragm	Brass UNS-C84400, Teflon Coated	1
4	--	Cover	Ductile Iron 65-45-12, Halar® Coated	1
5	07046BN	Clapper	Brass UNS-C84400, Teflon Coated	1
6	12055	Upper Diaphragm	EPDM ASTM D-2000	1
7	04225B	Rubber Seat Assembly	EPDM ASTM D-2000/Stainless Steel UNS-S30400	1
8	--	Data Plate	Aluminum Etched	1
9	08091	Screw, H.H.C. ¹ , 3/8-16x1-1/8 (29 mm)	Stainless Steel UNS-S30400	10
10	08214	Screw, R.H. ² , 10-24 x 1/2 (13 mm)	#400 Monel	8
11	*	Screw, R.H. ² , 10-24 x 5/8 (16 mm)	#400 Monel	4
12	*	O-Ring	EPDM	1
13	08412	Washer	Stainless Steel	12

-- Indicates no replacement part available

* Indicates part available only in sub-assembly listed below

SUB-ASSEMBLY

2, 11-12	14712-2	Seat Replacement Kit*
3, 5-7, 9, 10, 13	13396	Clapper Assembly Kit

¹ Hex Head Cap Screw ² Round Head, Phillips Drive Screw

***Note:** Includes o-ring lubricant to be added to ring groove in seat.

Note: Do not damage the coating, or complete valve replacement will be required.