

	<h1 style="margin: 0;">TECHNICAL DATA</h1>	<p><b>2" MODEL G-2000P</b>  <b>DOUBLE INTERLOCK PREACTION</b>                  WITH ELECTRIC/PNEUMATIC RELEASE</p>
---	--	--

The Viking Corporation, 210 N Industrial Park Drive, Hastings MI 49058

Telephone: 269-945-9501 Technical Services: 877-384-5464 Fax: 269-818-1680 Email: techsvcs@vikingcorp.com

**1. DESCRIPTION**

**Viking supervised Double-Interlocked Electric/Pneumatic Release Preaction Systems utilize the Viking G-2000P Valve.** The small profile, lightweight, pilot operated Viking Model G-2000P Valve comes complete as shown in Figure 8.

The system piping is pressurized with air or nitrogen to serve both as a means of supervising the integrity of the piping network and as one portion of the system release operation. This feature serves to prevent undetected leaks on the system piping network. If the system piping or a sprinkler is damaged, the supervisory pressure is reduced and a "low air" supervisory alarm is activated.

**This pilot operated externally reset valve also includes an internal check diaphragm, which eliminates the need for a separate check valve being installed in the system riser.**

Double interlocked electric/pneumatic release preaction systems require the use of one 24 VDC normally closed (NC) electric solenoid and one pneumatic actuator. The electric solenoid is connected to a compatible release control panel and compatible detection devices. The pneumatic actuator is controlled by the air pressure that is contained within the sprinkler system piping. In fire conditions, both the solenoid and a sprinkler must open in order for the G-2000P Valve to operate. When both the solenoid and pneumatic actuator open, the priming water is relieved from the internal prime chamber assembly. The prime chamber assembly collapses, and water passes through the G-2000P Valve and internal check diaphragm to the system piping network. The entire sprinkler system fills with water.

Double interlock electric/pneumatic release preaction systems are commonly used in cold storage applications and other areas where it is important to control accidental water discharge due to inadvertent damage to the sprinkler piping.

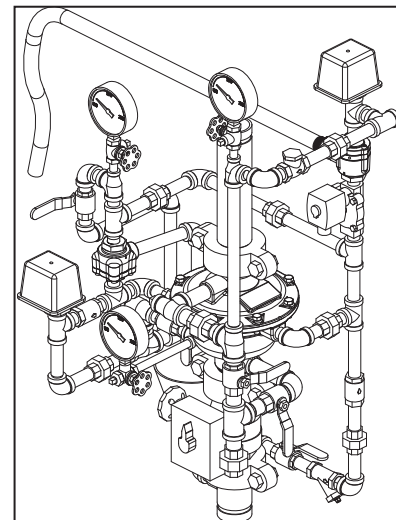

**2. LISTING AND APPROVALS**

 **cULus Listed:** VLFT

 **FM Approved:** Refrigerated Area Sprinkler Systems

**3. TECHNICAL DATA**

**Specifications:**

Pressure Rating: 250 PSI (17.2 Bar) Water Working Pressure

Factory Hydrostatically Tested to: 500 PSI (34.5 bar)

Friction Loss (Given in feet of Schedule 40 pipe based on Hazen & Williams formula C = 120):

Model G-2000P Valve: 8.5'

10" Section of Pipe: 1'

Water Supply Control Valve: 1.9'

Model G-2000P Valve C<sub>v</sub> Factor: 115.6

Valve Color: Black

**Material Specifications:**

Refer to Figure 11.

**Ordering Information:**

Available since 2010.

Part Number: G-2000P Double Interlock Electric/Pneumatic Preaction Riser Assembly: 16188-1 (Refer to Figure 8)

**Accessories:** (Refer to Figure 9)

Drain Manifold: 16211

Model E-1 Accelerator: 08055

Model LD-1 Anti-Column Device: 14800

$$Q = C_v \sqrt{\frac{\Delta P}{S}}$$

Q = Flow  
 C<sub>v</sub> = Flow Factor (GPM/1 PSI ΔP)  
 ΔP = Pressure Loss through Valve  
 S = Specific Gravity of Fluid

**4. INSTALLATION:**

**A. General Installation Instructions**

1. For proper operation and approval, the valve must be installed in the vertical position as trimmed from the factory. DO NOT modify the factory assembled trim except as described in this technical data sheet.
2. A 10" section of pipe is provided with the G-2000P Double Interlock Electric/Pneumatic Preaction Riser Assembly. Prior to valve maintenance, this section of pipe may be removed to provide clearance for lifting the cover from the body.
3. The G-2000P Valve must be installed in an area not subject to freezing temperatures or physical damage. If required, provide

Viking Technical Data may be found on The Viking Corporation's Web site at <http://www.vikinggroupinc.com>. The Web site may include a more recent edition of this Technical Data Page.



# TECHNICAL DATA

**2" MODEL G-2000P**  
**DOUBLE INTERLOCK PREACTION**  
WITH ELECTRIC/PNEUMATIC RELEASE

The Viking Corporation, 210 N Industrial Park Drive, Hastings MI 49058

Telephone: 269-945-9501 Technical Services: 877-384-5464 Fax: 269-818-1680 Email: techsvcs@vikingcorp.com

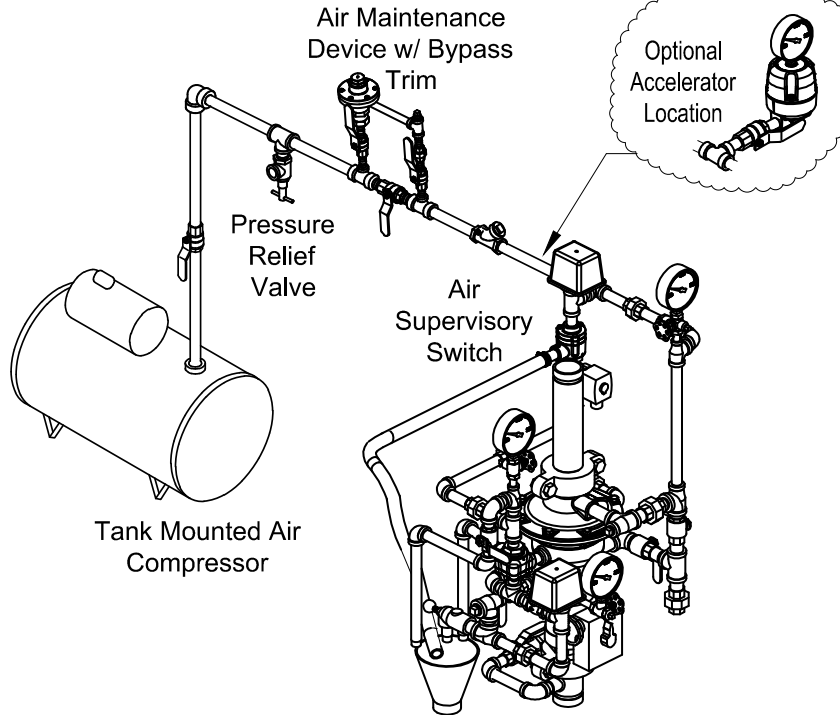

**Tank Mounted Air Compressor Option**

Viking Model D-2 Air Maintenance Device

Warning - Do not allow pressures in excess of 175 psi from reaching the AMD.

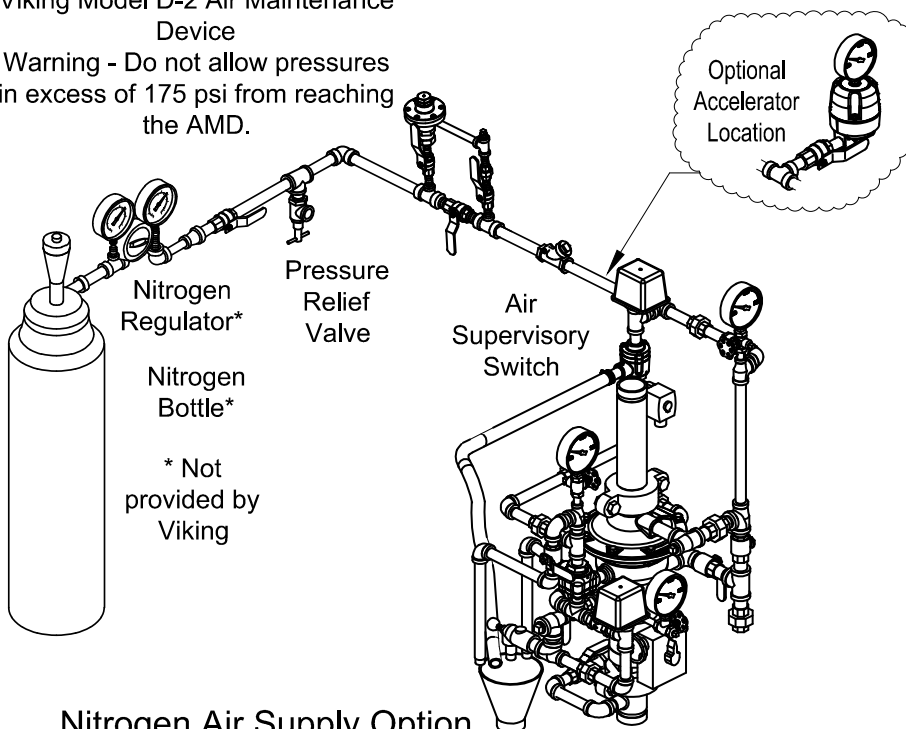

**Nitrogen Air Supply Option**

**Figure 1 - Air Supply Options**

	<h1 style="margin: 0;">TECHNICAL DATA</h1>	<p><b>2" MODEL G-2000P</b>  <b>DOUBLE INTERLOCK PREACTION</b>                  WITH ELECTRIC/PNEUMATIC RELEASE</p>
---	--	--

The Viking Corporation, 210 N Industrial Park Drive, Hastings MI 49058  
 Telephone: 269-945-9501 Technical Services: 877-384-5464 Fax: 269-818-1680 Email: techsvcs@vikingcorp.com

Pipe Diameter		Capacity			
US	International	Schedule 40 (1" to 6") Schedule 30 (8")		Schedule 10	
		Gal / Ft	L / m	Gal / Ft	L / m
1"	DN25	0.045	0.559	0.049	0.608
1-1/4"	DN32	0.078	0.969	0.085	1.043
1-1/2"	DN40	0.106	1.316	0.115	1.428
2"	DN50	0.174	2.161	0.190	2.360
2-1/2"	DN65	0.248	3.080	0.283	3.515
3"	DN80	0.383	4.756	0.434	5.390
3-1/2"	DN90	0.513	6.370	0.577	7.165
4"	DN100	0.660	8.196	0.740	9.190
5"	DN125	1.040	12.915	1.144	14.206
6"	DN150	1.501	18.640	1.649	20.477
8"	DN200	2.660	33.032	2.776	30.472

For Metric Units 1 Ft. = 0.3048 M, 1 Gal. = 3.785L

	System Pressure	
	Up to 175 PSI (12 bar)	175 PSI (12 bar) to 250 PSI (17 bar)
<b>For Systems with Tank-Mounted Compressors:</b>		
Air Maintenance Device	30 PSI (2.1 bar)	50 PSI (3.45 bar)
Air Supervisory Switch	25 PSI (1.7 bar)	45 PSI (3.1 bar)
<b>For Systems with Riser Mounted Compressors:</b>		
Compressor On/Off Switch	30 PSI (2.1 bar) / 40 PSI (2.8 bar)	50 PSI (3.45 bar) / 60 PSI (4.1 bar)
Air Supervisory Switch	25 PSI (1.72 bar)	45 PSI (3.10 bar)

Compressor Size (HP)	Free Air @ 40 PSI (2.8 bar) (cfm)	Max System Size to Pump to 40 PSI (2.8 bar) in 30 Minutes (Gal)
1/6	1.0	90
1/3	2.0	180
1/2	3.1	300
1	5.9	600

a valve house (enclosure) with adequate heat around the G-2000P Valve and trim. Freezing temperatures will damage the G-2000P Valve. When corrosive atmospheres and/or contaminated water supplies are present, it is the owner's responsibility to verify compatibility with the G-2000P Valve and associated equipment.

- The Viking Model E-1 Accelerator should be installed at the location indicated in Figure 1 when required.

**B. Air Supply Design**

1. Air Compressor Size

Viking recommends tank-mounted air compressors for Double Interlock Electric/Pneumatic Release Preaction Systems. The pneumatic actuator requires at least 30 PSI (2.1 bar) of air pressure be established within the piping network for systems with water pressure up to 175 PSI (12.1 bar) and 50 PSI (3.45 bar) of air pressure for systems with water pressures up to 250 PSI (17.2 bar).

NFPA 13 requires the air supply to be capable of filling the entire sprinkler system to its required air pressure within 30 minutes. A common method of sizing an air compressor is to use the following formula:

<p>Compressor Size (cfm) = <math>\frac{V \times P}{7.48 \times 14.7 \times T}</math></p>	<p><b>Where:</b>                  V = Volume                  P = Required Air Pressure                  T = Fill time (typically 30 min.)                  7.48 = gal. / ft.<sup>3</sup>                  14.7 = atmospheric pressure</p>	<p><b>Example:</b>                  System volume as determined by table 1 = 750 gallons                  Required Air pressure = 30 PSI</p> <p>Compressor Size (cfm) = <math>\frac{(750 \times 30)}{7.48 \times 14.7 \times 30} = 6.8 \text{ cfm}</math></p>
--	--	---

Therefore, the compressor shall be capable of providing 7 cfm.

2. Nitrogen Cylinder Gas Supply (See Figure 1)

Nitrogen may be used in place of air compressors. Nitrogen is supplied in pressurized cylinders in various sizes and pressures. Some of the most common are 122 Cu. Ft. at 1,900 PSI (3,455 L at 131 bar), 225 Cu. Ft. at 2,100 PSI (6,372 L at 145 bar), and 280 Cu. Ft. at 2,300 PSI (7,930 L at 159 bar).

When nitrogen cylinders are used as a primary air supply, spare cylinders should be furnished and located at the valve location. To determine the approximate amount of nitrogen to be furnished, the following formula may be used:

English Units	
<p><math>V_c = \frac{V_s \times P}{100}</math></p>	<p><b>Where:</b>                  V<sub>c</sub> = Volume of Cylinder (ft<sup>3</sup>)                  P = Required Nitrogen Pressure (PSI<sub>g</sub>)                  V = Volume of System (gal)</p>

Metric Units	
<p><math>V_c = \frac{V_s \times P}{108}</math></p>	<p><b>Where:</b>                  V<sub>c</sub> = Volume of Cylinder (L)                  P = Required Nitrogen Pressure (bar)                  V = Volume of System (L)</p>



# TECHNICAL DATA

**2" MODEL G-2000P**  
**DOUBLE INTERLOCK PREACTION**  
 WITH ELECTRIC/PNEUMATIC RELEASE

The Viking Corporation, 210 N Industrial Park Drive, Hastings MI 49058

Telephone: 269-945-9501 Technical Services: 877-384-5464 Fax: 269-818-1680 Email: techsvcs@vikingcorp.com

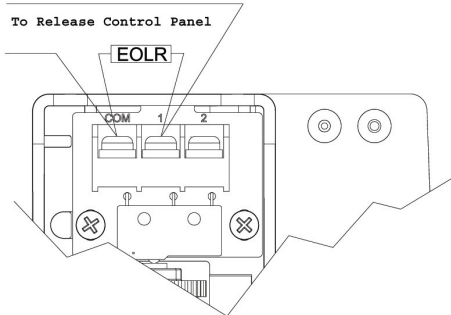

**Figure 2 - Alarm Pressure Switch Wiring**  
 (Alarm Pressure Switch should be set to 5 PSI (0.34 bar))

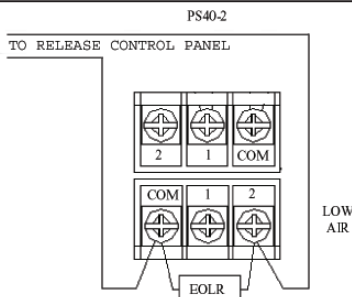

**Figure 3 - Air Supervisory Switch Wiring**

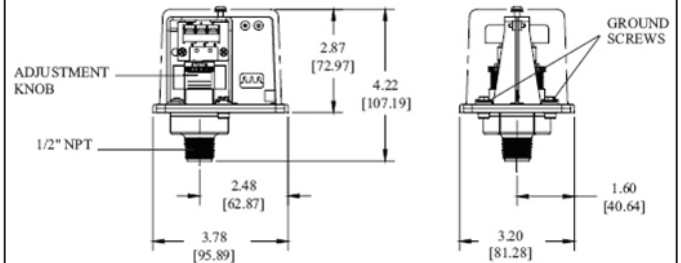

**FIELD ADJUSTMENTS:**

**Alarm Pressure Switch:** The operating point of the switch can be adjusted to any point between 4 PSI (0.27 bar) and 8 PSI (0.55 bar) by turning the adjustment knob(s) clockwise to raise the actuation point or counter-clockwise to lower the actuation point.

**Air Supervisory Switch:** The operating point of the switches can be adjusted to any point between 10 PSI (0.7 bar) and 60 PSI (4.1 bar) by turning the adjustment knob(s) clockwise to raise the actuation point or counter-clockwise to lower the actuation point. The high and low switches are adjusted independently.

**Figure 4 - Pressure Adjustment**

Special attention must be given to systems employing a bottled-gas supply. Because only a limited amount of gas is available, small leaks (which normally would go unnoticed in systems being supplied by mechanical compressors) can become critical to the system's overall performance. If the system is to function at temperatures as low as -40 °F (-40 °C), and, if bottled nitrogen is the gas supply, the system is particularly susceptible to leakage, and special care should be taken to ensure against leaks throughout the entire system.

**C. Air Supply Installation**

1. Install the required air supply as described in section 4.B. The size of the compressor and amount of air required should be determined in accordance with Tables 1, 2 & 3. The air or nitrogen supply to the preaction system must be clean, dry, and oil free.
2. Automatic air supplies must be regulated, restricted, and from a continuous source. A Viking Air Maintenance Device should be installed on each system equipped with a tank mounted compressor, plant air or nitrogen. For compressors with a capacity less than 5.5 ft<sup>3</sup>/min at 10 PSI (0.154 m<sup>3</sup>/min at 0.69 bar), NFPA 13 does not require an air maintenance device. The use of an air maintenance device with riser mounted compressors can lead to compressor "short cycling". Viking always recommends that a tank-mounted compressor with air maintenance device be used. This can become critical when accelerators are installed on the system.

**D. Pressure Switch Wiring;**

Wire the Alarm Pressure Switch (PS10) and Air Supervisory Switch (PS40), and adjust the pressure settings as shown in Figures 2 - 4.

**E. Hydrostatic Test:**

The Preaction System, including Sprinkler Piping and Sprinklers shall be hydrostatically tested at 200 PSI (13.79 bar) and maintained for two hours, in accordance with NFPA 13. Systems normally subjected to working system pressures in excess of 150 PSI (10.34 bar) shall be tested at a pressure of 50 PSI (3.45 bar) in excess of system working pressure.

**F. Placing the Valve in Service:** (Refer to Figure 5)

When the Preaction System is ready to be placed in service, verify that the pneumatic release system is in a normal condition and that the electric release system has been reset.

1. Verify that the water supply main control valve (not shown) supplying the G-2000P Valve is closed.
2. Close the prime valve.
3. Open the main drain valve.
4. Open the flow test valve.
5. Drain all water from the preaction system. If the system has operated, or if water has entered the system, allow enough time to completely drain the system.



# TECHNICAL DATA

**2" MODEL G-2000P**  
**DOUBLE INTERLOCK PREACTION**  
 WITH ELECTRIC/PNEUMATIC RELEASE

The Viking Corporation, 210 N Industrial Park Drive, Hastings MI 49058

Telephone: 269-945-9501 Technical Services: 877-384-5464 Fax: 269-818-1680 Email: techsvcs@vikingcorp.com

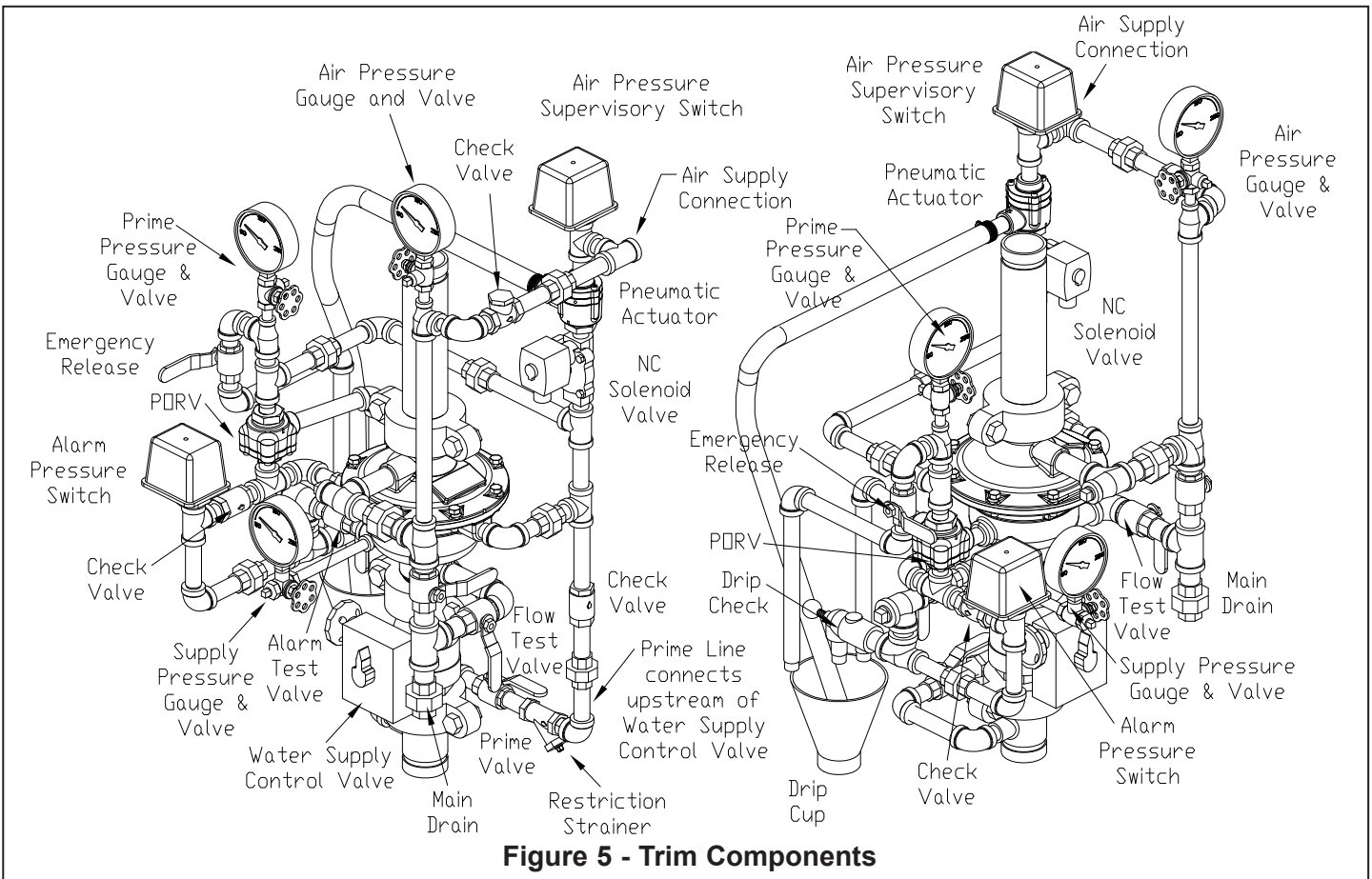

**Figure 5 - Trim Components**

6. Close the main drain valve.
7. Open the priming valve. Prime water pressure will enter and expand the valve's internal diaphragm assembly onto the valve seat, effectively closing the valve. Verify prime pressure has been established on the prime pressure gauge.
8. Establish air pressure on the system.
9. Verify that no water flows from the drip check when the plunger is pushed.
10. When the priming pressure has been verified as being established, slowly open the water supply control valve (not shown).
11. When flow is developed from the flow test valve, CLOSE the flow test valve.
12. Fully open the water supply main control valve.
13. Secure all valves in their normal operating position.
14. Reset the release control panel.
15. Notify Authorities Having Jurisdiction and those in the affected area that the system is in service.
16. The system is now fully operational.

### G. Operational Test:

An operational test shall be performed on the system in accordance with NFPA 13. Refer to Section 6 for Inspection and Operation Test Procedures.





# TECHNICAL DATA

**2" MODEL G-2000P**  
**DOUBLE INTERLOCK PREACTION**  
WITH ELECTRIC/PNEUMATIC RELEASE

The Viking Corporation, 210 N Industrial Park Drive, Hastings MI 49058

Telephone: 269-945-9501 Technical Services: 877-384-5464 Fax: 269-818-1680 Email: techsvcs@vikingcorp.com

## 5. OPERATION

### A. In the Set position:

When air pressure is introduced into the sprinkler piping, the sensing end of the pneumatic actuator is pressurized. This closes the pneumatic actuator. The closed pneumatic actuator and the normally closed solenoid valve prevent prime water from escaping the prime chamber of the G-2000P Valve. When prime water enters the prime chamber, the rolling diaphragm is pressurized, causing it to expand downward onto the water seat.

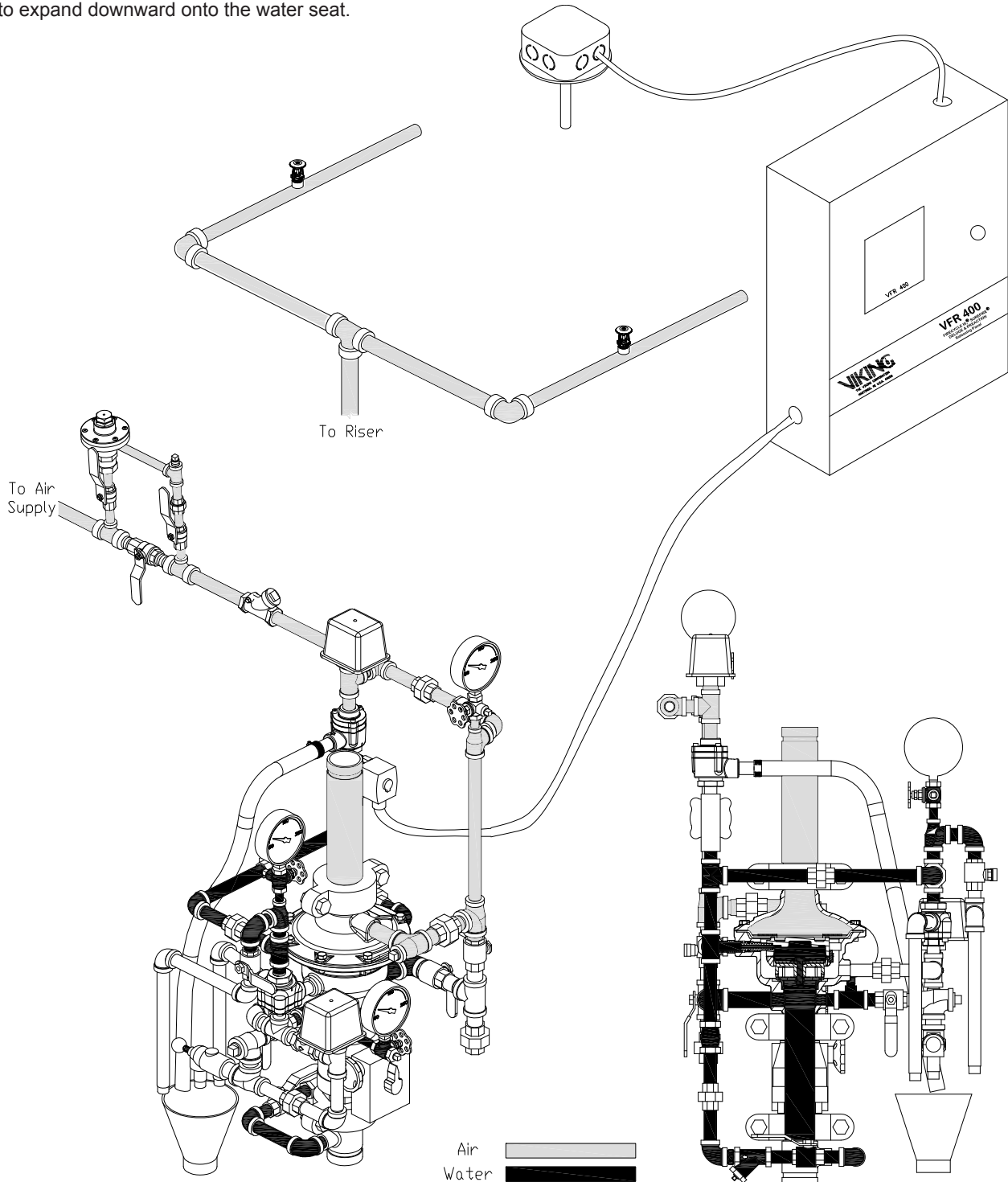

**Figure 6 - Set Position**



# TECHNICAL DATA

**2" MODEL G-2000P  
DOUBLE INTERLOCK PREACTION  
WITH ELECTRIC/PNEUMATIC RELEASE**

The Viking Corporation, 210 N Industrial Park Drive, Hastings MI 49058

Telephone: 269-945-9501 Technical Services: 877-384-5464 Fax: 269-818-1680 Email: techsvcs@vikingcorp.com

### B. Fire Condition:

When the detection system operates, the normally closed solenoid valve is powered open. At this point, the prime water is still held in the prime chamber by the closed pneumatic actuator. When a sprinkler operates, air pressure is lost on the sensing end of the pneumatic actuator, causing the pneumatic actuator to open. With both the pneumatic actuator and solenoid valve open, prime water is drained from the prime chamber, causing the G-2000P Valve to open, filling the sprinkler piping with water. Water from the intermediate chamber of the G-2000P Valve pressurizes the sensing end of the PORV, causing the PORV to open. The open PORV prevents water pressure from building in the prime chamber should the solenoid or pneumatic actuator close.

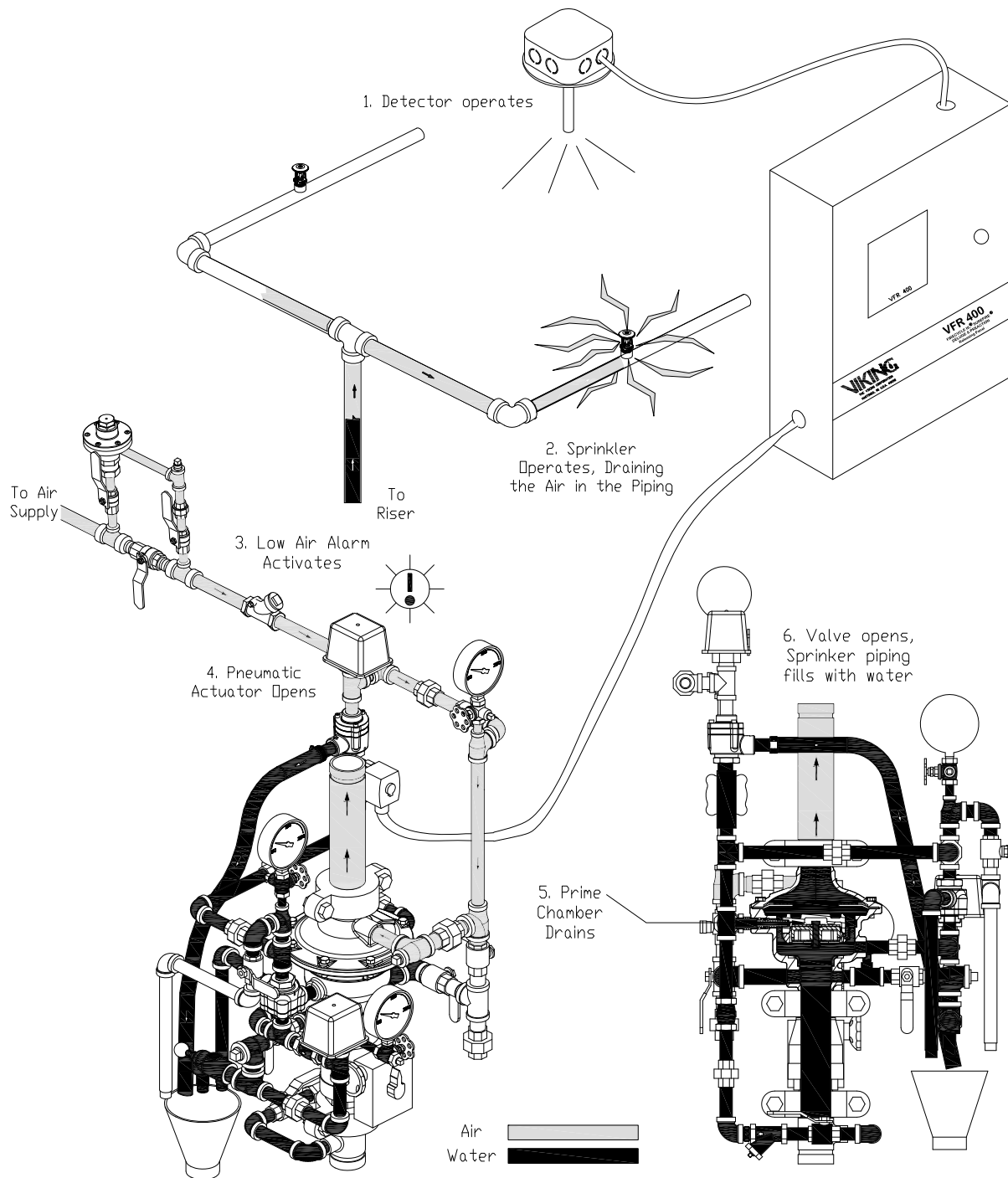

Figure 7 - Fire Condition



## TECHNICAL DATA

**2" MODEL G-2000P**  
**DOUBLE INTERLOCK PREACTION**  
 WITH ELECTRIC/PNEUMATIC RELEASE

The Viking Corporation, 210 N Industrial Park Drive, Hastings MI 49058

Telephone: 269-945-9501 Technical Services: 877-384-5464 Fax: 269-818-1680 Email: techsvcs@vikingcorp.com

### 6. INSPECTION AND OPERATIONAL TEST

**NOTICE: THE OWNER IS RESPONSIBLE FOR MAINTAINING THE FIRE PROTECTION SYSTEM AND DEVICES IN PROPER OPERATING CONDITION.** It is imperative that the system is inspected and tested on a regular basis in accordance with NFPA 25. The frequency of the inspections may vary due to contaminated water supplies, corrosive water supplies, corrosive atmospheres, as well as the condition of the air supply to the system. For minimum maintenance and inspection requirements, refer to NFPA 25. In addition, the Authority Having Jurisdiction may have additional maintenance, testing, and inspection requirements that must be followed. Viking does not require internal inspection of the valve as part of routine inspection and testing. Internal maintenance is generally only required for valve repairs and internal component replacement.

**WARNING:** Any system maintenance that involves placing a control valve or detection system out of service may eliminate the fire protection capabilities of that system. Prior to proceeding, notify all Authorities Having Jurisdiction. Consideration should be given to employment of a fire patrol in the affected areas.

#### A. Low Air Pressure Alarm Test: (Refer to Figure 5)

Quarterly testing of low air alarms is recommended.

To Test Sprinkler System "Low Supervisory Air" Alarm:

1. To prevent operation of the G-2000P Valve and filling the system with water during the test, DO NOT operate the electric detection system during test. Consider closing the main water supply control valve.
2. Fully open the sprinkler system test connection.
3. Verify that low air alarms operate within an acceptable time period and continue without interruption.
4. Close the test connection.
5. Establish recommended pneumatic supervisory pressure to be maintained. Refer to section 4. INSTALLATION.
6. Reset the system release control panel. Alarms should stop.

**When testing is complete, return the system to service following steps 1 through 8 below.**

#### B. Full Flow Trip Test: (Refer to Figure 5)

Performance of a trip test is recommended annually during warm weather. Consider coordinating this test with operation testing of the detectors.

**CAUTION! PERFORMANCE OF THIS TEST WILL CAUSE THE G-2000P VALVE TO OPEN AND THE SPRINKLER SYSTEM TO FILL WITH WATER.**

To Trip Test the Electric / Pneumatic Double-Interlocked Preaction System:

1. Notify the Authority Having Jurisdiction and those in the area affected by the test.
2. Trip the G-2000P Valve by performing option "a" or "b" below.
  - a. Operate the electric release control system according to the manufacturer's instructions, and open the sprinkler system test connection.
  - b. Operate the emergency release valve .
3. The G-2000P Valve should open, filling the sprinkler system with water. Water flow alarms should operate.
4. Verify that there is adequate flow from the sprinkler system test valve.

**When Trip Testing is complete:**

5. Perform steps 1 through 13 of section 4.F. PLACING THE SYSTEM IN SERVICE to return the system to service.
6. Notify the Authority Having Jurisdiction and those in the affected area that testing is complete.

### 7. MAINTENANCE

Viking does not require an internal inspection of the G-2000P Valve unless there is an indication of damage to internal components.

#### A. Taking the system out of service: (Refer to Figure 5)

1. Close the water supply main control valve, placing the system out of service.
2. Open the flow test valve located in the base of the G-2000P Valve.
3. Close the air (or nitrogen) supply to the preaction system piping.
4. Close the priming valve.
5. Relieve all pressure from the preaction system piping. If the system has operated, open main drain valve to allow the system to drain completely.

#### B. Removing the Cover from the Body: (Refer to Figures 1 & 11)

1. Remove the 2" grooved coupling from the top of the G-2000P Valve.
2. Remove the 10" section of pipe directly above the G-2000P Valve.
3. Break the 1/2" coupling between the air pressure fauge and air pressure supervisory switch.
4. Remove the 3/4" union below the main drain.
5. Remove the 8 cover screws (8).



**TECHNICAL DATA****2" MODEL G-2000P  
DOUBLE INTERLOCK PREACTION  
WITH ELECTRIC/PNEUMATIC RELEASE****The Viking Corporation, 210 N Industrial Park Drive, Hastings MI 49058****Telephone: 269-945-9501 Technical Services: 877-384-5464 Fax: 269-818-1680 Email: techsvcs@vikingcorp.com**

6. The cover (9) and trim that is still connected may now be removed from the valve body. (It may be necessary to pry the valve open as the diaphragm may bond itself to the cover (9) and body over time.)

**C. Removing / Replacing the Check Diaphragm:** (Refer to Figure 11)

1. The check diaphragm (7) may be lifted from the valve body (1).
2. If necessary, replace the check diaphragm (7).

**D. Inspecting the Prime Chamber and Coupling for Leaks:** (Refer to Figure 11)

If desired, it is possible to set the G-2000P Valve and inspect for leaks with the cover (9) removed.

1. Slowly open the prime valve.
2. With prime water established, partially open the main water supply control valve.
3. Visually inspect the inside of the G-2000P Valve for leaks.

**E. Removing / Replacing the Prime Coupling:** (Refer to Figure 11)

1. Open the 1/2" union on the prime line.
2. Using a wrench on the flats of the coupling (6), remove the coupling (6) from the valve body (1).
3. Inspect the coupling (6) and O-rings. Replace if necessary, using the instructions in O-Ring Replacement Bulletin F\_120611.

**F. Removing / Replacing the Prime Chamber Assembly:** (Refer to Figure 11)

1. The prime chamber assembly (4) is now held in place by two flanges on the outside diameter of the assembly. Slide the prime chamber assembly (4) toward the prime line and remove from the body.
2. Inspect and replace if necessary.
3. Inspect the seat. The seat should be clean and free of foreign material. If the seat is damaged, the G-2000P Valve must be replaced.

**G. Re-Assembling the Valve:** (Refer to Figure 11)

1. Place the prime chamber assembly (4) in the valve body (1). Make sure the two flanges are positioned in the groove.
2. Thread the prime coupling (6) into the valve body (1). Make sure the end of the prime coupling (6) is inserted into the prime chamber assembly (4).
3. Lay the check diaphragm (7) into the valve body (1).
4. Position the cover (9) onto the valve body (1), and install and tighten the cover screws (8).
5. Re-install any trim that was removed.
6. Place the valve in service by following the steps in Section 4.F.

**8. AVAILABILITY**

The Viking Model G-2000P Valve is available through a network of domestic and international distributors. See the Viking Corp. Web site for closest distributor or contact The Viking Corporation.



# TECHNICAL DATA

**2" MODEL G-2000P  
DOUBLE INTERLOCK PREACTION  
WITH ELECTRIC/PNEUMATIC RELEASE**

The Viking Corporation, 210 N Industrial Park Drive, Hastings MI 49058

Telephone: 269-945-9501 Technical Services: 877-384-5464 Fax: 269-818-1680 Email: techsvcs@vikingcorp.com

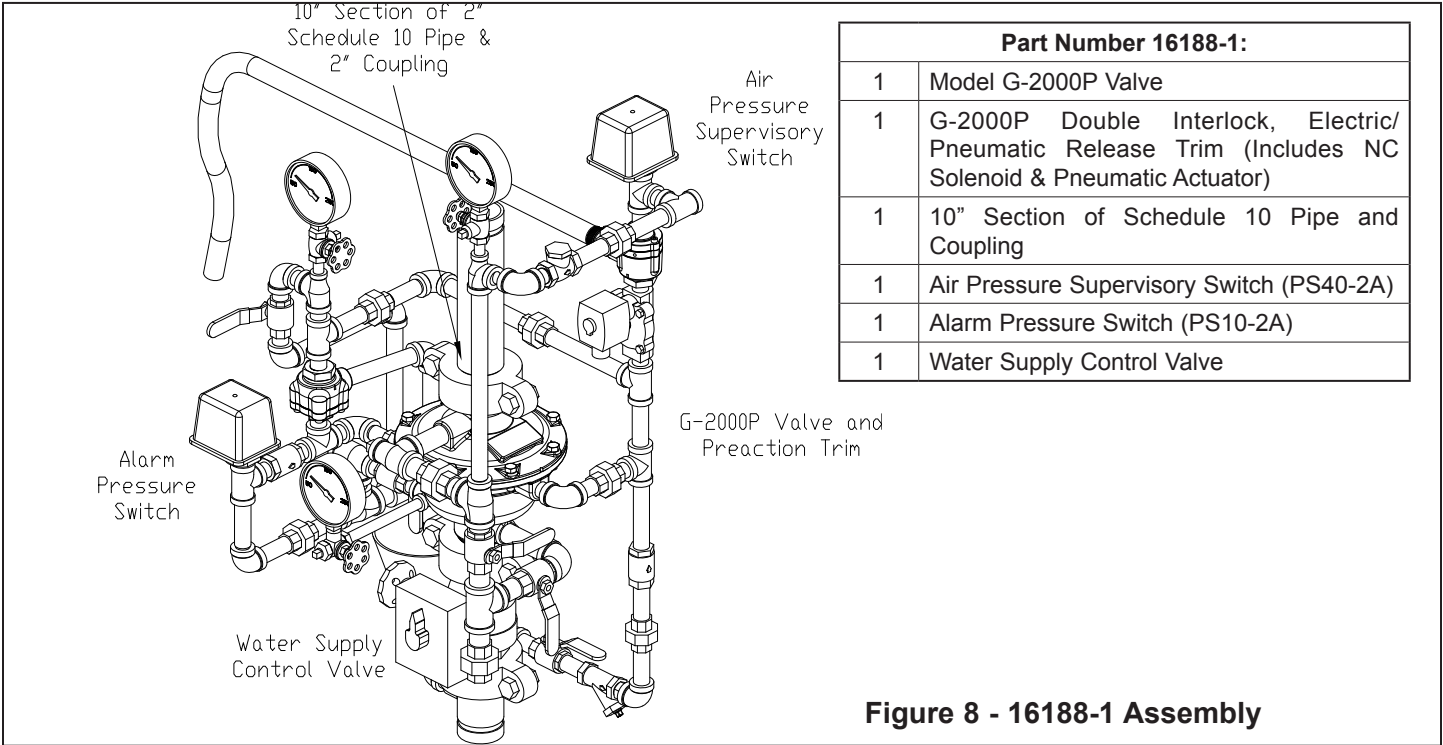

**Figure 8 - 16188-1 Assembly**

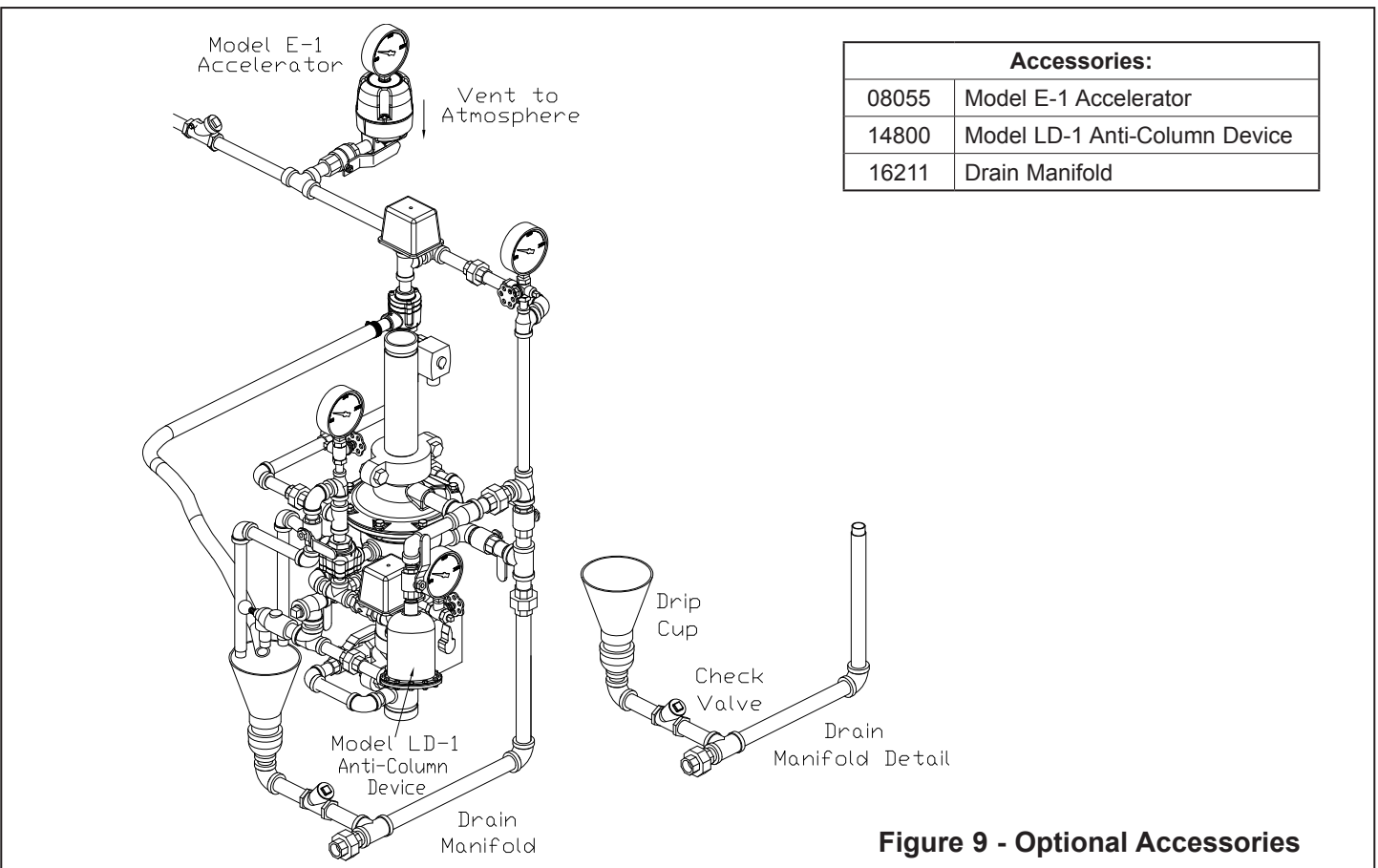

**Figure 9 - Optional Accessories**



**TECHNICAL DATA**

**2" MODEL G-2000P  
DOUBLE INTERLOCK PREACTION  
WITH ELECTRIC/PNEUMATIC RELEASE**

The Viking Corporation, 210 N Industrial Park Drive, Hastings MI 49058

Telephone: 269-945-9501 Technical Services: 877-384-5464 Fax: 269-818-1680 Email: techsvcs@vikingcorp.com

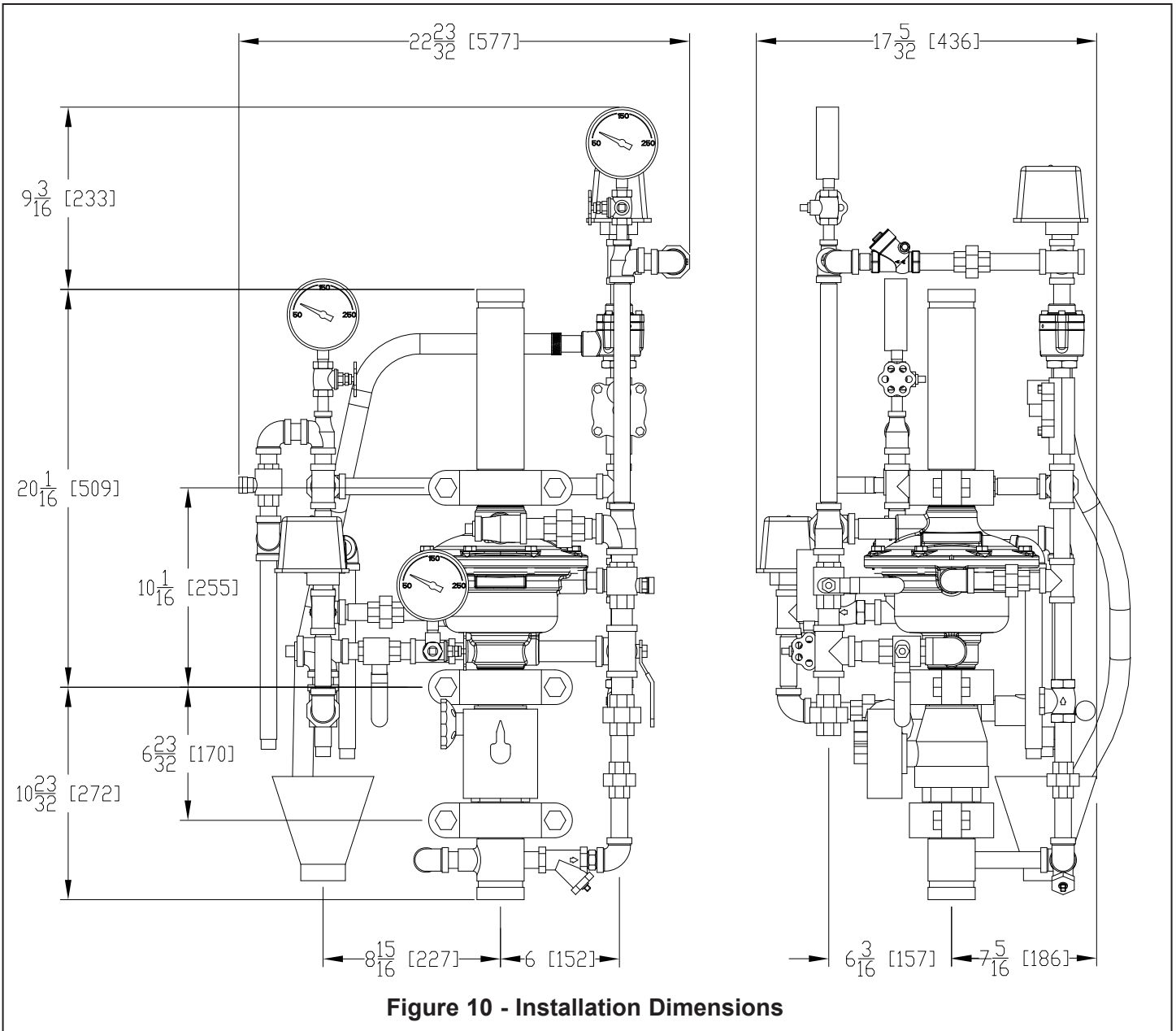



# TECHNICAL DATA

**2" MODEL G-2000P**  
**DOUBLE INTERLOCK PREACTION**  
 WITH ELECTRIC/PNEUMATIC RELEASE

The Viking Corporation, 210 N Industrial Park Drive, Hastings MI 49058  
 Telephone: 269-945-9501 Technical Services: 877-384-5464 Fax: 269-818-1680 Email: techsvcs@vikingcorp.com

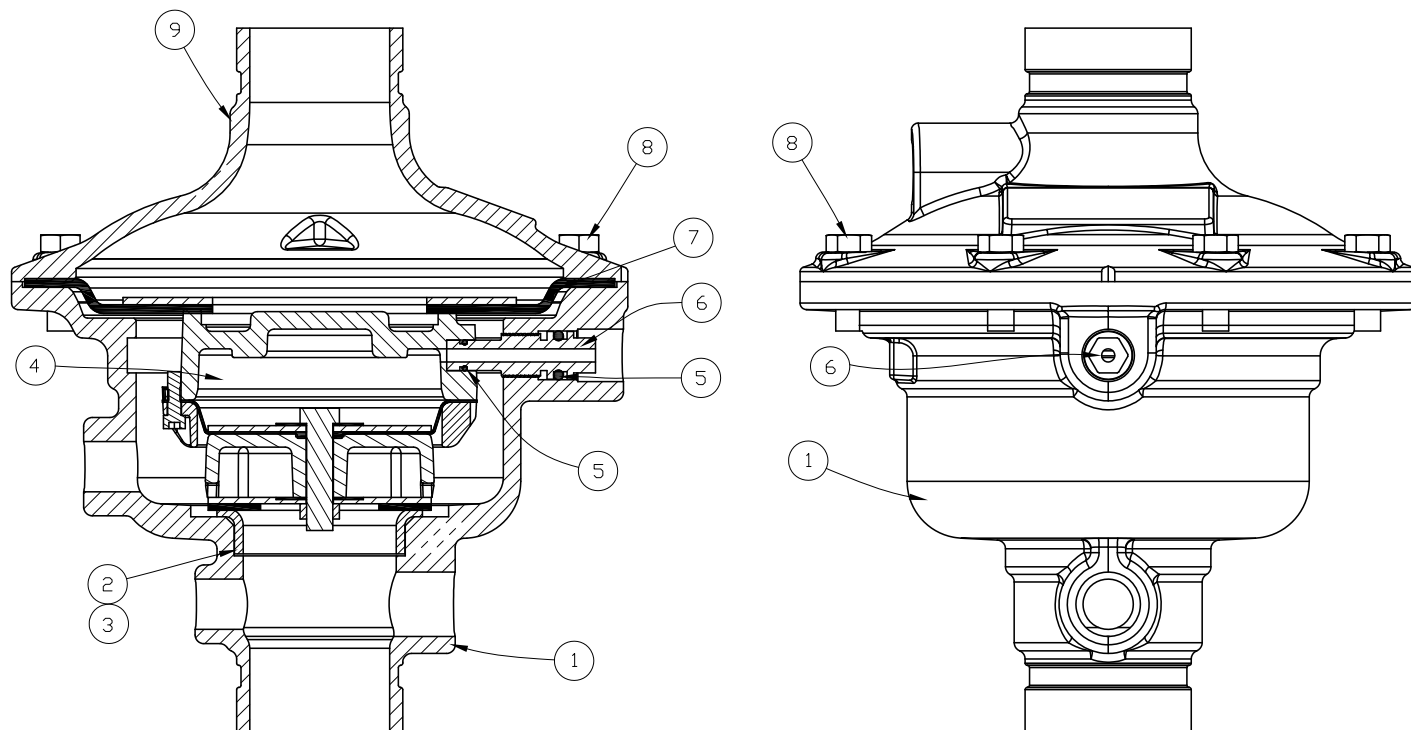

**Figure 11 - Model G-2000P Valve Components List/Replacement Parts**

Item No.	Part No.	Description	Material	No. Req'd
1	--	Body	65-45-12 Ductile Iron	1
2	--	Seat	UNS-C11000 Copper or UNS-S30400 Stainless Steel	1
3	--	Anaerobic Adhesive	--	1
4	16063	Prime Chamber Assembly	Brass, EPDM, Nitrile, 304 Stainless Steel, Bronze Alloy	1
5	*	O-Rings	EPDM and Nitrile	2 or 3**
6	16062	Coupling	UNS-S17400 Stainless Steel	1
7	15932	Check Diaphragm	EPDM	1
8	08091	3/8-16 x 1" HHS	UNS-S30400 Stainless Steel	8
9	--	Cover	65-45-12 Ductile Iron	1
10	--	Data Plate	Aluminum	2
11	--	Tack	Alloy Carbon Steel	4

-- Replacement part is not available.

\* Indicates part is available only in a Sub-Assembly, as indicated below.

**Sub-Assembly**

5	17443	O-Ring Replacement Kit (**Refer to O-Ring Replacement Bulletin Form No. F_120611 for instructions.)
---	-------	---