

## 2½" Gate Valve with Female Screw Inlet

### GV-SF25

#### Technical Features

- **Nominal Size** : 65 mm
- **Pressure Data** : Hydrostatically tested to 16.5 bar and 22.5 bar for the valve seat and body
- **Inlet** : Female Threaded
- **Outlet** : Female instantaneous to BS 336
- **Flowrate** : 10 l/sec at 4.1bar.
- **Friction Loss** : 0.7 bar at flowrate of 10 l/sec.
- **Body Material** : Gunmetal BS1400 LG2
- **Weight** : 6.75 kg.
- **Features** :
  - Compact design with excellent flow characteristics
  - High quality casting finishes
  - Precise machining for metal to metal leak proof seating
  - Corrosion resistant
  - Maintenance free
  - Complete with black plastic cap and chain
  - Straight-through design for ease of use
- **Part Number Straight Through** : GV-SF25

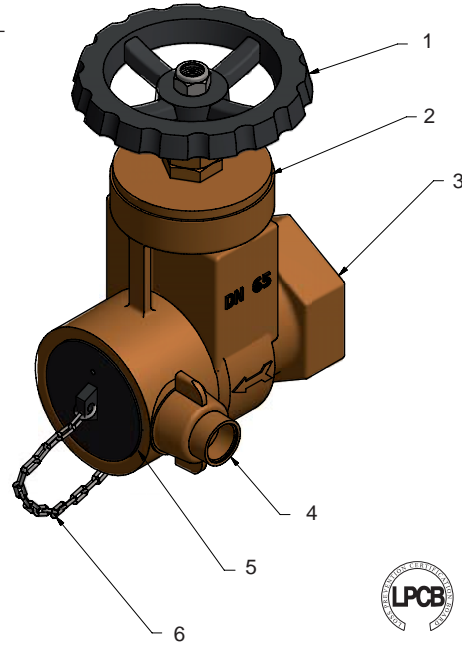

#### GV-SF25

#### Materials List

No.	Part	Material
1	Handwheel	Cast Iron
2	Bonnet	LG2 (Gunmetal)
3	Valve Body	LG2 (Gunmetal)
4	Plunger Release Lug	
5	Male Blank cap with Vent Hole	Plastic
6	S-Hook & Chain	

