

	<b>TECHNICAL DATA</b>	<b>RESIDENTIAL SPRINKLER EXTENSIONS</b>
---	-----------------------	---

**The Viking Corporation, 210 N Industrial Park Drive, Hastings MI 49058**

**Telephone: 269-945-9501 Technical Services: 877-384-5464 Fax: 269-818-1680 Email: techsvcs@vikingcorp.com**

**1. DESCRIPTION**

Viking residential sprinkler extensions are designed to provide the system designer and installer with a degree of flexibility in pipe placement and sprinkler installation. Available in 1", 1-1/8" and 1-1/4" lengths, the sprinkler extension makes up small amounts of space between the sprinkler and the pipe fitting helping to prevent unnecessary pipe fabrication and ensuring proper sprinkler placement as it relates to the finished ceiling.

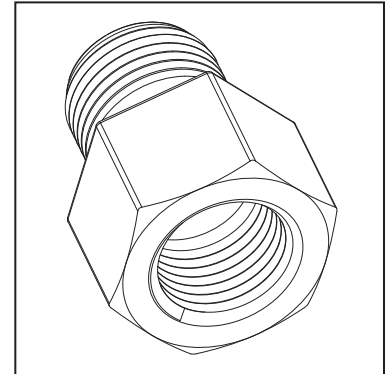

**2. LISTINGS AND APPROVALS**

**UL Listed:** Category VNTW

For use with listed residential sprinklers with a nominal K-Factor of 5.5 (79.3 bar) or less only. For retrofit only. Refer to the residential sprinkler technical data pages for sprinkler listings and approvals.

**3. TECHNICAL DATA**

**Specifications:**

Inlet & Outlet - 1/2" NPT

**Material Standards:**

Brass UNS-C84400

Viking Technical Data may be found on  
The Viking Corporation's Web site at  
<http://www.vikinggroupinc.com>.  
The Web site may include a more recent  
edition of this Technical Data Page.

Length of Extension	Part Number
1" (25.4 mm)	14959
1-1/8" (28.6 mm)	14960
1-1/4" (31.8 mm)	14961

**Ordering Information:** (Also refer to the current Viking price list.)

**NOTE: Sprinklers and sprinkler extensions must be ordered separately.**

**4. INSTALLATION**

The extensions come standard with 1/2" threads for connection to the pipe fitting. When installing the extension, apply a small amount of pipe-joint compound or tape to the external threads of the extension only, taking care not to allow a buildup of compound in the extension inlet. Thread the extension into the fitting hand tight. Using a pipe wrench, fully tighten the extension an additional one turn to one and a half turns. Use extreme caution and do not over-tighten into pipe fitting. Carefully review the fitting manufacturer's installation recommendations to ensure compliance. Following the specific sprinkler instructions found on the sprinkler technical data sheet and/or care and handling guides, install the sprinkler into the extension.

**5. OPERATION**

Refer to the residential sprinkler technical data pages.

**6. INSPECTIONS, TESTS AND MAINTENANCE**

Refer to NFPA 25 for Inspection, Testing and Maintenance requirements.

**7. AVAILABILITY**

Viking products are available through a network of domestic and international distributors. See The Viking Corporation web site for the closest distributor or contact The Viking Corporation.

**8. GUARANTEE / LIMITED WARRANTY**

For details of warranty, refer to Viking's current list price schedule or contact Viking directly.

**This page intentionally  
left blank**