



Section M
Dry Pipe Systems

TABLE OF CONTENTS

Dry Pipe System (Model G) M-1
Dry Pipe System (Model F)..... M-2
Accelerators / Air Maintenance Devices..... M-3
Accessories and Components M-4

Notes

1. Refer to Viking technical data pages for complete product specifications. You may print or download technical data by visiting www.vikinggroupinc.com.
2. List prices effective January 12, 2019. Supersedes June 2018 list price book.
3. All sales by Viking are subject to the Terms & Conditions found on the last page of this book.

Model G Dry System (Pre-Assembled) - EXTERNALLY RESETTABLE VALVE



Model G Dry System - EXTERNAL RESET	
<i>Complete, pre-assembled dry valve and trim includes the following:</i>	
- Model G Dry Valve	
- Model G Trim Package	
- Water Supply Control Valve	
- Air Pressure Supervisory Switch (PS40-2A)	
- Alarm Pressure Switch (PS10-1A)	
- 12" (0,3 m) Section of Galvanized Schedule 10 Pipe (with Coupling)	

Model	Size	Part Number	List Price	Item Price Group
G-2000	2"	16149-1	\$8,421.87	V232
G-3000	3"	16150-1	\$9,242.77	V232
G-4000	4"	15647-1	\$9,882.14	V232
G-6000	6"	17048-1	\$11,626.04	V232

Model G Dry System - Optional Drain Manifold Assembly

Model	Size	Part Number	List Price	Item Price Group
G-2000	2"	16211	\$460.38	V232
G-3000	3"	16212	\$592.25	V232
G-4000	4"	15588	\$664.44	V232
G-6000	6"	17056	\$664.44	V232

Model G Dry Systems - DOMESTIC USA OPTION				
Model	Size	Part Number	List Price	Item Price Group
G-2000	2"	16149-1USA	\$8,838.07	V232
G-3000	3"	16150-1USA	\$13,203.94	V232
G-4000	4"	15647-1USA	\$14,117.34	V232
G-6000	6"	17048-1USA	\$16,608.62	V232

See page M-2 for Viking's Model F dry valve and trim.
 Model G valve also available in pre-action arrangement. See section O for details.
 Domestic trim option meets sourcing requirements of the Buy American Act, American Reinvestment and Recovery Act, and the Buy America Law.

Model F-1 Dry System

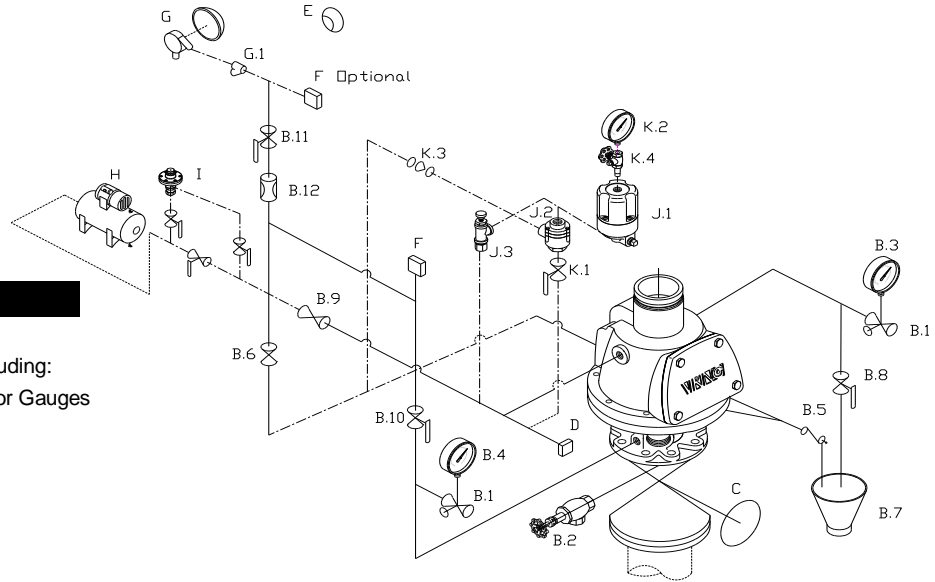

Description

- A Model F-1 Dry Pipe Valve
- B Model F-1 Dry Valve Trim including:
 - B.1 Side Outlet Globe Valve for Gauges
 - B.2 Angle Valve
 - B.3 Air Gauge
 - B.4 Water Gauge
 - B.5 Drip Check Valve
 - B.6 Drain Check Valve
 - B.7 Drain Cup
 - B.8 Priming Water Test Valve
 - B.9 1/2" / DN15 Spring Loaded Check Valve
 - B.10 Alarm Test Valve
 - B.11 Alarm Shut-Off Valve
 - B.12 7/32" / 5mm Restricted Orifice
- C Water Supply Control Valve
- D Air Pressure Supervisory Switch
- E Electric Alarm Bell
- F Alarm Pressure Switch
- G Model F-2 Water Motor Alarm (inc G.1 Y-strainer)
- H Maintenance Air Compressor

Description (continued)

- I Model D-2 Air Maintenance Device and Trim
- J Accelerator / Anti-Flood Package including:
 - J.1 Model E-1 Accelerator
 - J.2 Model B-1 Anti-Flood Device
 - J.3 Model B-1 Float Check Valve Assembly
- K Accelerator / Anti-Flood Trim including:
 - K.1 1/2" / DN15 Anti-Flood Isolation Valve
 - K.2 Air Gauge
 - K.3 1/2" / DN15 Swing Check Valve
 - K.4 Side Outlet Valve for Accelerator Gauge

Trims include indented items immediately following.

Flange / Flange (Model F-1) Dry Valve							
Size	Valve (only)		Loose Trim ¹ (galvanized)		Modular Trim ¹ (galvanized)		Valve/Trim (pre-trimmed)
IPG	V228		V229		V230		V231
3"	09441	\$4,268.31	10158	\$1,644.95	10158P	\$1,963.22	09441PT \$6,218.12
4"	07628	\$4,783.82	08395	\$1,680.71	08395P	\$1,999.33	07628PT \$6,478.83
6"	08464	\$5,981.36	09456	\$1,680.71	09456P	\$1,999.33	08464PT \$7,608.58
Flange / Groove (Model F-1) Dry Valve							
Size	Valve (only)		Loose Trim ¹ (galvanized)		Modular Trim ¹ (galvanized)		Valve/Trim (pre-trimmed)
IPG	V228		V229		V230		V231
3"	09446	\$4,268.31	10158	\$1,644.95	10158P	\$1,963.22	09446PT \$6,315.90
4"	07627	\$4,783.82	08395	\$1,680.71	08395P	\$1,999.33	07627PT \$6,867.56
6"	08491	\$5,981.36	09456	\$1,680.71	09456P	\$1,999.33	08491PT \$8,065.10
Groove / Groove (Model F-2) Dry Valve							
Size	Valve (only)		Loose Trim ¹ (galvanized)		Modular Trim ¹ (galvanized)		Valve/Trim ² (pre-trimmed)
IPG	V228		V229		V230		V231
3"	13764	\$4,268.31	10158	\$1,644.95	10158P	\$1,963.22	13764PTR \$7,109.40
4"	13765	\$4,783.82	08395	\$1,680.71	08395P	\$1,999.33	13765PTR \$7,527.59
6"	13766	\$5,981.36	09456	\$1,680.71	09456P	\$1,999.33	13766PTR \$8,782.18

(1) Trim includes dry valve accessory pkg (p/n 08397). See page M-4 for details.

(2) Pre-assembled with nipples, fittings, water supply control valve, switches, and gauges. See tech data F_122216 for details.



Size	DOMESTIC TRIM ^{1,2}	
IPG	V229	
3"	10158USA	\$2,349.90
4"	08395USA	\$2,401.05
6"	09456USA	\$2,401.05



(2) Meets sourcing requirements of the Buy American Act, American Reinvestment and Recovery Act, and Buy American Law.

See page M-3 for accelerators and air maintenance devices. See page M-4 for additional accessories.



Accelerators / Air Maintenance Devices

Accelerator / Anti-Flood Packages (and Trim)

<p>Accelerator (D-2)</p>  <table border="1"> <thead> <tr> <th>Model D-2</th> <th>List Price</th> </tr> </thead> <tbody> <tr> <td>09881</td> <td>\$1,820.48</td> </tr> </tbody> </table> <p style="text-align: right;">V226</p>	Model D-2	List Price	09881	\$1,820.48	<p>Accelerator Trim (Model D-2) (Galvanized)</p> <table border="1"> <thead> <tr> <th>Model D-2</th> <th>List Price</th> </tr> </thead> <tbody> <tr> <td>09730</td> <td>\$431.47</td> </tr> <tr> <td colspan="2" style="background-color: #cccccc;">DOMESTIC¹</td> </tr> <tr> <th>Model D-2</th> <th>List Price</th> </tr> <tr> <td>09730USA</td> <td>\$575.29</td> </tr> </tbody> </table>  <p style="text-align: right;">V222</p>	Model D-2	List Price	09730	\$431.47	DOMESTIC¹		Model D-2	List Price	09730USA	\$575.29
Model D-2	List Price														
09881	\$1,820.48														
Model D-2	List Price														
09730	\$431.47														
DOMESTIC¹															
Model D-2	List Price														
09730USA	\$575.29														

<p>Accelerator (E-1) / Anti-Flood Device (B-1)</p>  <p style="text-align: right;">V226</p> <table border="1"> <thead> <tr> <th colspan="2"><i>E-1 Accelerator (only)</i></th> </tr> </thead> <tbody> <tr> <td>08055</td> <td>\$1,516.50</td> </tr> </tbody> </table>  <table border="1"> <thead> <tr> <th colspan="2"><i>B-1 Anti-Flood device (only)</i></th> </tr> </thead> <tbody> <tr> <td>08061</td> <td>\$874.37</td> </tr> </tbody> </table> <table border="1"> <thead> <tr> <th>Accelerator/Anti-Flood Package</th> <th>Part #</th> <th>List Price</th> </tr> </thead> <tbody> <tr> <td>(include E-1 and B-1)</td> <td>08116</td> <td>\$1,795.29</td> </tr> </tbody> </table> <p style="text-align: center;">Use only with tank-mounted air compressor and listed air maintenance device</p>	<i>E-1 Accelerator (only)</i>		08055	\$1,516.50	<i>B-1 Anti-Flood device (only)</i>		08061	\$874.37	Accelerator/Anti-Flood Package	Part #	List Price	(include E-1 and B-1)	08116	\$1,795.29	<p>Accelerator / Anti-Flood Trim (galvanized)</p> <table border="1"> <thead> <tr> <th colspan="2">STANDARD</th> <th colspan="2">DOMESTIC¹</th> </tr> <tr> <th>Part #</th> <th>List Price</th> <th>Part #</th> <th>List Price</th> </tr> </thead> <tbody> <tr> <td>08264</td> <td>\$620.33</td> <td>08264USA</td> <td>\$827.09</td> </tr> </tbody> </table> <p>Includes:</p> <ul style="list-style-type: none"> - Air Gauge - ½" / 15mm Anti-Flood Isolation Vlv - ½" / 15mm Swing Check Valve - Nipples, Fittings, Plugs - Float Check Valve <p style="text-align: right;">V222</p> <p style="text-align: center;">Use with Model-F dry valve, Model-F dry valve trims, accelerator/anti-flood package</p>	STANDARD		DOMESTIC¹		Part #	List Price	Part #	List Price	08264	\$620.33	08264USA	\$827.09
<i>E-1 Accelerator (only)</i>																											
08055	\$1,516.50																										
<i>B-1 Anti-Flood device (only)</i>																											
08061	\$874.37																										
Accelerator/Anti-Flood Package	Part #	List Price																									
(include E-1 and B-1)	08116	\$1,795.29																									
STANDARD		DOMESTIC¹																									
Part #	List Price	Part #	List Price																								
08264	\$620.33	08264USA	\$827.09																								

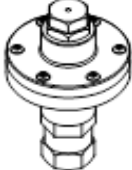
Air Maintenance Device (and trim) - IPG V226











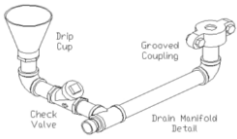



<p>Model D-2 - Air Pressure Maintenance Device</p>  <table border="1"> <thead> <tr> <th>Size</th> <th>Part #</th> <th>List Price</th> </tr> </thead> <tbody> <tr> <td>¼" / DN8</td> <td>02280C</td> <td>\$724.07</td> </tr> </tbody> </table> <p style="text-align: right;">V226</p>	Size	Part #	List Price	¼" / DN8	02280C	\$724.07	<p>Model D-2 - Air Pressure Maintenance Device</p>  <table border="1"> <thead> <tr> <th>Size</th> <th>Part #</th> <th>List Price</th> </tr> </thead> <tbody> <tr> <td>½" / DN15</td> <td>07459</td> <td>\$1,272.39</td> </tr> <tr> <td colspan="3" style="background-color: #cccccc;">DOMESTIC¹</td> </tr> <tr> <th>Size</th> <th>Part #</th> <th>List Price</th> </tr> <tr> <td>½" / DN15</td> <td>07459USA</td> <td>\$1,696.51</td> </tr> </tbody> </table> <table border="1"> <thead> <tr> <th>Filter Kit</th> <th>Part #</th> <th>List Price</th> </tr> </thead> <tbody> <tr> <td>V249</td> <td>03007A</td> <td>\$43.92</td> </tr> </tbody> </table> <p style="text-align: right;">V226</p>	Size	Part #	List Price	½" / DN15	07459	\$1,272.39	DOMESTIC¹			Size	Part #	List Price	½" / DN15	07459USA	\$1,696.51	Filter Kit	Part #	List Price	V249	03007A	\$43.92
Size	Part #	List Price																										
¼" / DN8	02280C	\$724.07																										
Size	Part #	List Price																										
½" / DN15	07459	\$1,272.39																										
DOMESTIC¹																												
Size	Part #	List Price																										
½" / DN15	07459USA	\$1,696.51																										
Filter Kit	Part #	List Price																										
V249	03007A	\$43.92																										

Air Compressor - IPG V226

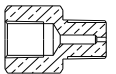

<p>Model G-1 Maintenance Air Compressor (includes mounting bracket)</p>															
	<table border="1"> <thead> <tr> <th>Model</th> <th>Part #</th> <th>List Price</th> </tr> </thead> <tbody> <tr> <td>115V single phase, 60 Cycle AC - Service Factor Amperage: 7.4, Factory Wired 115 V</td> <td>19191</td> <td>\$3,519.07</td> </tr> <tr> <td>230V single phase, 60 Cycle AC - Service Factor Amperage: 3.7, Factory Wired 230 V</td> <td>19192</td> <td>\$3,533.31</td> </tr> <tr> <td>230V single phase, 50 Cycle AC - Service Factor Amperage: 2.6, Factory Wired 230 V</td> <td>19193</td> <td>\$3,369.69</td> </tr> </tbody> </table>	Model	Part #	List Price	115V single phase, 60 Cycle AC - Service Factor Amperage: 7.4, Factory Wired 115 V	19191	\$3,519.07	230V single phase, 60 Cycle AC - Service Factor Amperage: 3.7, Factory Wired 230 V	19192	\$3,533.31	230V single phase, 50 Cycle AC - Service Factor Amperage: 2.6, Factory Wired 230 V	19193	\$3,369.69		
Model	Part #	List Price													
115V single phase, 60 Cycle AC - Service Factor Amperage: 7.4, Factory Wired 115 V	19191	\$3,519.07													
230V single phase, 60 Cycle AC - Service Factor Amperage: 3.7, Factory Wired 230 V	19192	\$3,533.31													
230V single phase, 50 Cycle AC - Service Factor Amperage: 2.6, Factory Wired 230 V	19193	\$3,369.69													

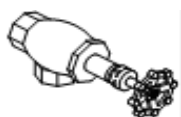
(1) Meets sourcing requirements of Buy American Act, American Reinvestment and Recovery Act, and Buy American Law.

Accessories (Included with standard dry valve trim)

Model G Optional Drain Manifold Assembly  <p style="text-align: right;">V232</p>				Dry Valve Accessory Package Includes: - Drip Check Valve - Drain Cup - Valve Reset Bar - 7/32" / 5mm Restricted Orifice - 1/2" / 15mm Spring Loaded Check Valve - 1/4" / 8mm Restricted Orifice - Tubing Connector <p style="text-align: right;">IPG V226</p>																							
		<table border="1"> <thead> <tr> <th>Part Number</th> <th>List Price</th> </tr> </thead> <tbody> <tr> <td>08397</td> <td>\$597.99</td> </tr> </tbody> </table>		Part Number	List Price	08397	\$597.99																				
Part Number	List Price																										
08397	\$597.99																										
<table border="1"> <thead> <tr> <th>Model</th> <th>Size</th> <th>Part Number</th> <th>List Price</th> </tr> </thead> <tbody> <tr> <td>G-2000</td> <td>2"</td> <td>16211</td> <td>\$460.38</td> </tr> <tr> <td>G-3000</td> <td>3"</td> <td>16212</td> <td>\$592.25</td> </tr> <tr> <td>G-4000</td> <td>4"</td> <td>15588</td> <td>\$664.44</td> </tr> <tr> <td>G-6000</td> <td>6"</td> <td>17056</td> <td>\$664.44</td> </tr> </tbody> </table>		Model	Size	Part Number	List Price	G-2000	2"	16211	\$460.38	G-3000	3"	16212	\$592.25	G-4000	4"	15588	\$664.44	G-6000	6"	17056	\$664.44						
Model	Size	Part Number	List Price																								
G-2000	2"	16211	\$460.38																								
G-3000	3"	16212	\$592.25																								
G-4000	4"	15588	\$664.44																								
G-6000	6"	17056	\$664.44																								
Water Gauge 0-300 psi (2,068 kPa)  1/4" / DN8 VWATERSF \$26.41 SR295			Air Gauge 0-80 psi (554 kPa)  1/4" / DN8 VAIRSF \$26.41 SR295			Globe Valve for Gauges (side outlet)  1/4" / DN8 76V-25 \$20.66 SR140																					
Alarm Test/Alarm Shut-Off Valve (1/2" Ball Valve)  1/2" / DN15 10355 \$52.05 V226			Drain Cup  1 1/2" / DN40 01019B \$18.35 V226			Drain Check Valve  1/2" / DN15 05781A \$95.35 V226																					
Drip Check Valve - Model D-3 Velocity Check  3/4" / DN20 10732 \$170.35 V226			Dry Valve Wrench & Reset Bar  02977BW/B \$232.72 V226			Swing Check Valve  1/2" / DN15 KT403W-50 \$74.70 SR140																					
Restricted Orifice 1/16" / 1.5mm  1/4" / DN8 10110 \$37.07 V226			Restricted Orifice 7/32" / 5mm  1/2" / DN15 06980A \$20.30 V226																								
Angle Valve 1 1/2" / DN40 Use with 3" 03937S \$201.69 2" / DN50 Use with 4" 126SUL-0200 \$167.55 Use with 6" 126SUL-0200 \$167.55 			Anti-Column Device (Model LD-1)  14800 \$487.33 *install in vertical position V226 Install on dry systems where potential for water column exists downstream of dry valve			Anti-Column Device Trim 14816 \$186.54 V226																					
Float Check Valve (Model B-1/B-2)  <table border="1"> <thead> <tr> <th colspan="2">Brass - 1/2" / DN15 (B-1)</th> <th colspan="2">Corrosion Resistant (B-2)</th> </tr> </thead> <tbody> <tr> <td>12116</td> <td>\$315.03</td> <td>12084</td> <td>\$771.38</td> </tr> </tbody> </table> <p style="text-align: right;">V226</p>						Brass - 1/2" / DN15 (B-1)		Corrosion Resistant (B-2)		12116	\$315.03	12084	\$771.38														
Brass - 1/2" / DN15 (B-1)		Corrosion Resistant (B-2)																									
12116	\$315.03	12084	\$771.38																								

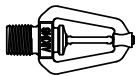
Accessories (NOT included with standard dry valve trim)

Dry Valve Wrench & Reset Bar  02977BW/B \$232.72 V226		Glass Strut Head (for Model B-1 accelerator)  03226C \$65.97 V249		Drip Check Valve (Model D-2) (for Model B-1 accelerator)  10731 \$266.39 V226	
--------------------------------------------------------------------------------------------------------------------------------------------------------------	--	----------------------------------------------------------------------------------------------------------------------------------------------------------------------	--	------------------------------------------------------------------------------------------------------------------------------------------------------------------------------------	--

