

N₂-Blast® | Corrosion Solutions

For Dry and Pre-action Fire Protection Systems



N₂-Blast®

Corrosion Inhibiting Solutions



www.southteksystems.com
commercialsales@southteksystems.com
888.526.6284





N₂-Blast®

Corrosion Inhibiting System

Introducing the N₂-Blast® - *Corrosion Inhibiting System*, recipient of the 2014 NACE Corrosion Innovation of the Year award. Designed and manufactured by South-Tek Systems, the leader in Nitrogen Generation Technology.

The N₂-Blast® generates and introduces 98%+ pure Nitrogen into the Dry or Pre-action Fire Protection System. In doing so, Oxygen, a key contributor to the corrosion reaction, is displaced from the piping through the *AutoPurge System™*. The N₂-Blast® effectively inhibits Electrochemical, Galvanic and Microbiologically Influenced Corrosion (MIC), as well as freeze-ups and ice plugs.

ABOUT SOUTH-TEK SYSTEMS

We ARE Nitrogen

Our team is dually focused on customer support and a technical, in-depth understanding of applications such as inhibiting corrosion in dry and pre-action fire protection systems - ensuring the ultimate user experience. Because of this dedication, South-Tek has become one of the largest manufacturers of Nitrogen Generation equipment with over 10,000 systems installed in the United States and abroad. Those range from the small start-up research laboratory or local industrial equipment shop to a full listing of Fortune 50 Industrial plant sites, many of which have chosen us as their worldwide standard for Nitrogen Generation.

With a commitment to ongoing research and development, we've created Patented technologies that maximize the longevity and efficiency of our Nitrogen Generators. Not only do we provide the best user experience, but we're the most innovative manufacturer of Nitrogen Generation technology in the world.

The Technology

South-Tek Systems utilizes Membrane or Pressure Swing Adsorption (PSA) technology in the N₂-Blast® - *Corrosion Inhibiting Systems* in order to efficiently separate Nitrogen molecules from the air we breathe. Membrane technology, used in our "Type 2" models, has a simple air flow design, is wall-mounted and easy to service. PSA technology, used in our "Type 1" and "Type 3" models, is extremely efficient, providing maximum Nitrogen output and system longevity.

The N₂-Blast® - *Corrosion Inhibiting System* is comprised of the following:

- N₂-Blast® - Nitrogen Generator
- Integrated BlastOff™ - *Leak Detection System*
- Integrated BlastOff™ - *Air Bypass Tamper Alarm*
- Nitrogen receiver/buffer tank
- Air Compressor and Refrigerated Air Dryer
- N₂-Blast® - *AutoPurge System*
- Quick-Check® - *Nitrogen Purity Sensor*

Supported by optional Start-up and Commissioning by a certified South-Tek Technician.

FPS SERIES NITROGEN GENERATORS

N₂-Blast® - FPS-650 (Type 1 System)

- | For up to 650 gal. of total sprinkler pipe capacity
- | UL 508A listed Industrial Control Panel
- | Pressure Swing Adsorption (PSA) technology
- | Patent Pending BlastOff™ - *Leak Detection System*
- | Available with BlastOff™ - *Air Bypass Tamper Alarm*
- | Features an integral Air Compressor
- | 28 gal. N₂ receiver tank (15.1" dia. x 49.5" H)
- | Includes Quick-Check® - *Portable N₂ Purity Sensor*

Specifications

- | Minimum nitrogen purity 98%
- | Dew point -40° to -70° F
- | Electrical 120 VAC, 20 AMPS
- | Dimensions 29.5" H x 12.7" W x 10.1" D



N₂-Blast® - FPS-1250 (Type 1 System)

- | For up to 1,250 gal. of total sprinkler pipe capacity
- | UL 508A listed Industrial Control Panel
- | Pressure Swing Adsorption (PSA) technology
- | Patent Pending BlastOff™ - *Leak Detection System*
- | Available with BlastOff™ - *Air Bypass Tamper Alarm*
- | Features an integral Air Compressor
- | Integrated 16.8 gal. N₂ receiver tank
- | Includes Quick-Check® - *Portable N₂ Purity Sensor*

Specifications

- | Minimum nitrogen purity 98%
- | Dew point -40° to -70° F
- | Electrical 120 VAC, 20 AMPS
- | Dimensions 67.5" H x 26" W x 18" D

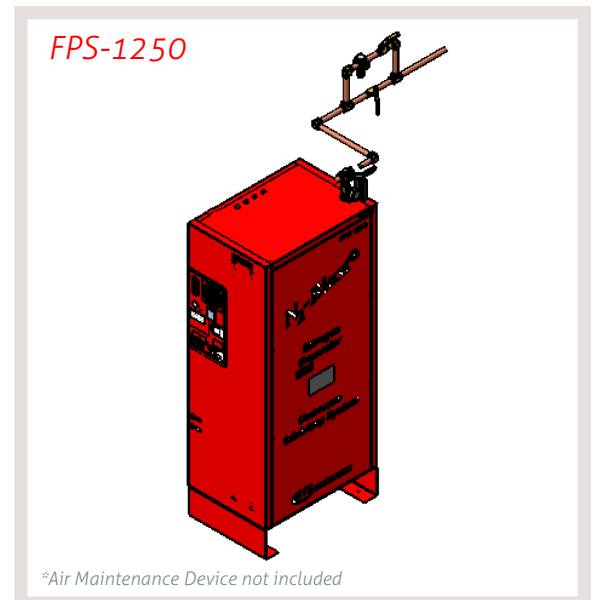

Notes:

- Type 1 systems are complete with integrated air compressors. A separate, basic air compressor can be provided upon request in order to fill the largest zone to pressure within 30 minutes (per NFPA 13 requirements). Also, a pre-existing air compressor can be utilized.
- Type 1 Annual Filter Replacement Kits include (2) Particulate and (1) Coalescing filter for each N₂-Blast®.

FPS SERIES NITROGEN GENERATORS

N₂-Blast® - FPS-1750/3000/6000 (Type 2 Systems)

- | (3) models available for up to 1,750, 3,000 or 6,000 gallons of total sprinkler pipe capacity
- | UL 508A listed Industrial Control Panel
- | Membrane technology
- | Patent Pending BlastOff™ - *Leak Detection System*
- | Available with BlastOff™ - *Air Bypass Tamper Alarm*
- | Requires an STS-NF-C Series Air Compressor Package
- | 28 gal. N₂ receiver tank (15.1" dia. x 49.5" H)
- | Includes Quick-Check® - *Portable N₂ Purity Sensor*

Specifications

- | Minimum nitrogen purity 98%
- | Dew point -40° to -70° F
- | Electrical 120 VAC, 8 AMPS
- | Dimensions 42.3" H x 14" W x 10" D

N₂-Blast® - FPS-15000/20000 (Type 3 Systems)

- | (2) models available for up to 15,000 or 20,000 gallons of total sprinkler pipe capacity
- | UL 508A listed Industrial Control Panel
- | Pressure Swing Adsorption (PSA) technology
- | Patent Pending BlastOff™ - *Leak Detection System*
- | Available with BlastOff™ - *Air Bypass Tamper Alarm*
- | Requires an STS-NF-C Series Air Compressor Package
- | Integrated 80 gal. N₂ receiver tank
- | Includes Quick-Check® - *Portable N₂ Purity Sensor*

Specifications

- | Minimum nitrogen purity 98%
- | Dew point -40° to -70° F
- | Electrical 120 VAC, 8 AMPS
- | Dimensions 71" H x 34" W x 41" D

Type 2 System

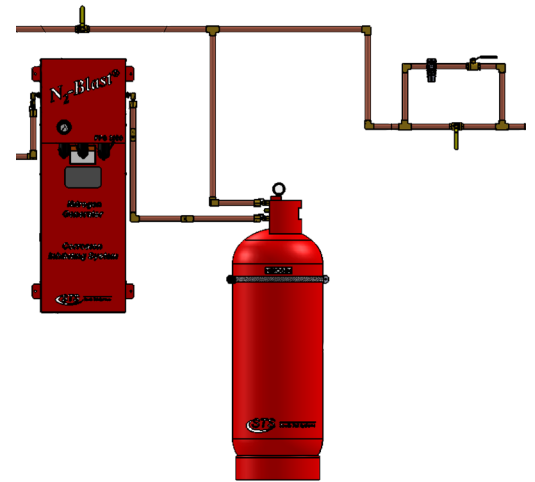

*Air Maintenance Device not included

Type 3 System

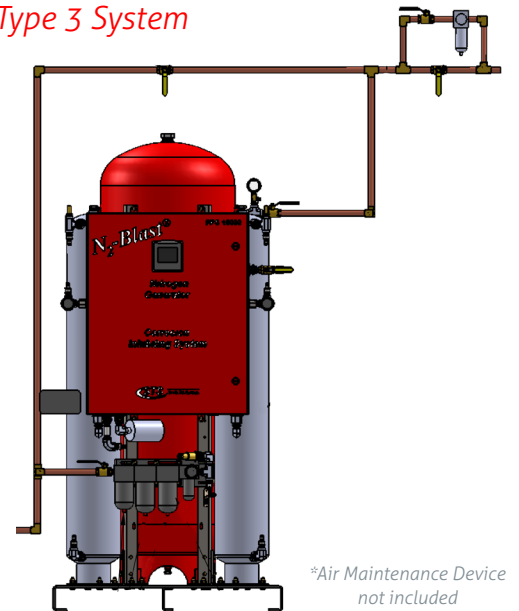

*Air Maintenance Device not included

Notes:

- Types 2 & 3 Annual Filter Replacement Kits include (1) Particulate, (1) Coalescing & (1) Adsorption filter for each N₂-Blast®.

FPS SERIES FEED AIR COMPRESSORS

STS-NF-C-2-J Air Compressor

- | 1 hp piston, oil lubricated with after-cooler package
- | 17 gal. accumulator tank with pneumatic auto-drain
- | Added filtration to ensure clean, dry, oil-free air
- | Compressed air flow output of 3.8 SCFM @ 125 PSI
- | Fills up to 575 gallons within 30 minutes (0-40 PSI)
- | Complete with refrigerated air dryer package

STS-NF-C-3-J Air Compressor

- | 2 hp piston, oil lubricated with after-cooler package
- | 17 gal. accumulator tank with pneumatic auto-drain
- | Added filtration to ensure clean, dry, oil-free air
- | Compressed air flow output of 7.6 SCFM @ 125 PSI
- | Fills up to 900 gallons within 30 minutes (0-40 PSI)
- | Complete with refrigerated air dryer package

STS-NF-C-4-CH Air Compressor

- | 3 hp piston, oil lubricated with after-cooler package
- | 60 gal. accumulator tank with pneumatic auto-drain
- | Added filtration to ensure clean, dry, oil-free air
- | Compressed air flow output of 10.9 SCFM @ 125 PSI
- | Fills up to 1,100 gallons within 30 minutes (0-40 PSI)
- | Complete with refrigerated air dryer package

STS-NF-C-5-CH Air Compressor

- | 5 hp piston, oil lubricated with after-cooler package
- | 80 gal. accumulator tank with pneumatic auto-drain
- | Added filtration to ensure clean, dry, oil-free air
- | Compressed air flow output of 17.3 SCFM @ 125 PSI
- | Fills up to 1,600 gallons within 30 minutes (0-40 PSI)
- | Complete with refrigerated air dryer package

STS-NF-C-6-CH Air Compressor

- | 7.5 hp piston, oil lubricated with after-cooler package
- | 80 gal. accumulator tank with pneumatic auto-drain
- | Added filtration to ensure clean, dry, oil-free air
- | Compressed air flow output of 23.1 SCFM @ 125 PSI
- | Fills up to 2,100 gallons within 30 minutes (0-40 PSI)
- | Complete with refrigerated air dryer package

STS-NF-C-7-CH Air Compressor

- | 10 hp piston, oil lubricated with after-cooler package
- | 120 gal. accumulator tank with pneumatic auto-drain
- | Added filtration to ensure clean, dry, oil-free air
- | Compressed air flow output of 34.8 SCFM @ 125 PSI
- | Fills up to 2,800 gallons within 30 minutes (0-40 PSI)
- | Complete with refrigerated air dryer package

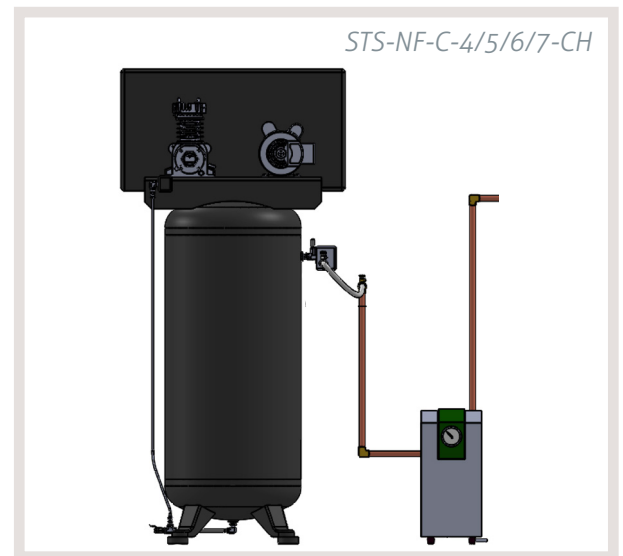
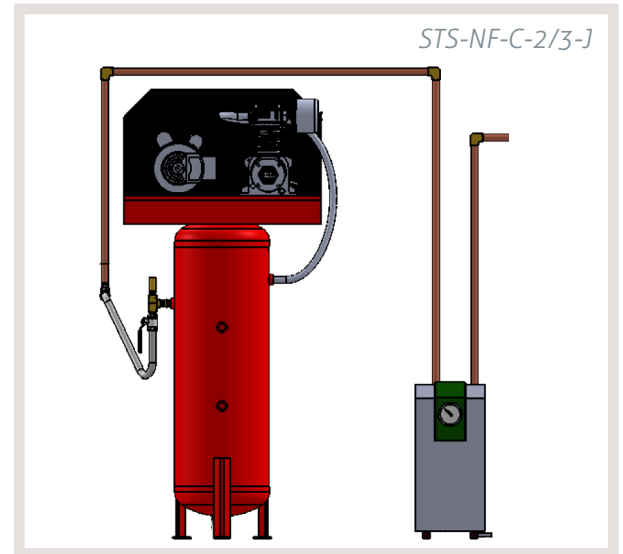

FPS SERIES ACCESSORIES



BMS Alarm Integration Options

South-Tek developed both the Patent Pending BlastOff™ - *Leak Detection System* and BlastOff™ - *Air Bypass Tamper Alarm* to proactively ensure the longevity of not only the FPS, but the Nitrogen generation system itself. The BlastOff™ - *Leak Detection System* acts as an onboard diagnostic to maximize the life of the supervisory equipment. If there is a leak downstream or an equipment malfunction, the *Leak Detection System* will alarm so that the problem can be diagnosed before the Nitrogen generator or air compressor burn out. The BlastOff™ - *Air Bypass Tamper Alarm* ensures 98%+ pure Nitrogen - *not compressed air* - is entering the FPS under normal operation. The *Air Bypass Tamper Alarm* safeguards against an install error or a technician inadvertently leaving the Nitrogen generator offline. This feature will alarm if the N₂-Blast® is bypassed by the air compressor or accidentally turned off.

N₂-Blast® - *AutoPurge System*™

High purity Nitrogen must be equally distributed throughout the entire FPS piping system in order to effectively inhibit corrosion. The Patent Pending *AutoPurge System*™ provides a low volume, constant purge of Nitrogen throughout each FPS system. The rate in which gas is purged from the FPS is within NFPA guidelines and allows breathing to occur within the sprinkler piping. The *AutoPurge System*™ also provides a point in which the Nitrogen purity concentration can be monitored downstream of the Nitrogen generator. Computational Fluid Dynamics modeling proves that this is the most effective way to ensure that high purity Nitrogen reaches all branches within the FPS. Install one *AutoPurge System*™ per zone at an area in which water will not collect.

Quick-Check® - *PowerSaver Manifold*

The Quick-Check® - *PowerSaver Manifold* option brings all of South-Tek's Patent Pending features together in one central location. Each *AutoPurge System*™ can be connected to the *PowerSaver Manifold* with 1/4" plenum-rated tubing (provided by South-Tek). The *PowerSaver Manifold* monitors Nitrogen purity within each Zone during a "sampling phase", once per day. At the end of the sampling phase, the *PowerSaver Manifold* stores the achieved Nitrogen purity into memory and displays the results on its screen. If the Zone's purity meets specification, the *AutoPurge System*™ will remain closed (not purging) until the next sampling phase. If purity does not meet specification, the *AutoPurge System*™ will remain in the "open" position and continue its purge until the next sampling phase (Nitrogen Generator provides the Zone with more Nitrogen until purity specification is met).

FPS SERIES ACCESSORIES

N₂-Blast® - AutoPurge System™

- | Cycles Nitrogen continuously through FPS piping to maximize corrosion protection
- | Mount horizontally on vertical section of FPS piping
- | Complete with NPT connection, auto high pressure water shut-off and adjustable AutoPurge System™ orifice
- | Fully pneumatic, no electric required
- | Tunable based on FPS capacity, minimizing Nitrogen generator runtime
- | Ensures 98%+ purity throughout FPS within (2) weeks



Quick-Check® - Sampling Port™

- | Provides additional location to check Nitrogen purity concentration within sprinkler piping
- | Offers peace of mind that Nitrogen is fully blanketed throughout FPS
- | One or multiple *Sampling Ports* can be installed on any Zone which already has an *AutoPurge System™*
- | Mount horizontally on a vertical section of FPS piping
- | No electric required



Quick-Check® - Portable Nitrogen Purity Sensor

- | Battery operated, hand-held Nitrogen analyzer verifies that desired Nitrogen purity is achieved within all zones
- | Attaches to quick connection on *AutoPurge System™* or *Sampling Port*



FPS SERIES ACCESSORIES

Quick-Check® - PowerSaver Manifold

- | Samples Nitrogen purity content in all Zones
- | Standard models: 1, 6, 10 and 20-port (custom models available upon request)
- | Deactivates each *AutoPurge System*™ as the Nitrogen purity set point is achieved
- | Maintenance mode periodically monitors Nitrogen purity in each Zone
- | Includes *maintenance log* app for capturing routine N₂-Blast® maintenance dates & notes
- | Equipped with 2gb micro SD card for data extraction
- | Optional ethernet communication module available for remote access
- | Wall mountable and complete with PLC and modules
- | Analog 0-10V, 4-20mA signal to BMS as purity is achieved
- | Electrical: 115V/60Hz/1Ph, 8 AMPS

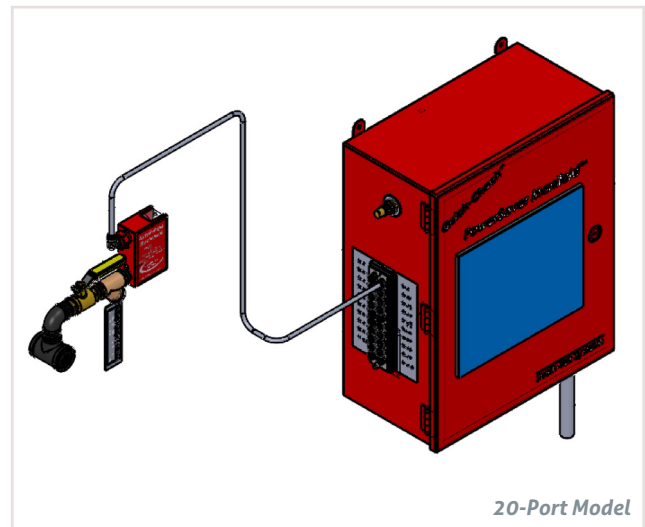
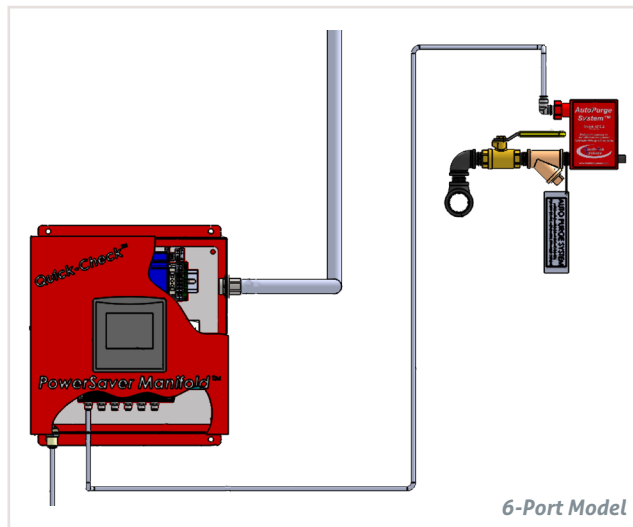

Quick-Check® - Ice Plug Alert System

- | Alerts if conditions within the sprinkler piping are conducive to the formation of ice plugs (i.e. the supervisory dew point is elevated to a level in which frozen condensate occurs)
- | Alerts if the main branch line is completely plugged with ice (i.e. water flow to the sprinkler head is restricted)
- | Monitors up to (4) zones and provides feedback via dry contact to the building monitoring system
- | Recommended for cold storage and freezer facilities, or other facilities where the sprinkler piping is exposed to freezing temperatures
- | Wall mountable and complete with PLC and modules
- | Electrical: 115V/60Hz/1Ph, 8 AMP

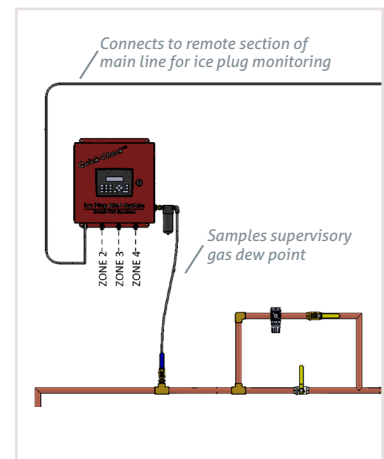

NITROGEN GENERATOR SPECIFICATIONS

	FPS-650	FPS-1250	FPS-1750	FPS-3000	FPS-6000	FPS-15000	FPS-20000
Maximum FPS Capacity (Gallons)	650	1,250	1,750	3,000	6,000	15,000	20,000
Dimensions (H x W x D)	30"x13"x10"	68"x26"x18"	42"x14"x10"	42"x14"x10"	42"x14"x10"	71"x34"x41"	71"x34"x41"
Weight¹	159 lbs.	140 lbs.	150 lbs.	151 lbs.	152 lbs.	798 lbs.	928 lbs.
Mount²	Wall	Skid	Wall	Wall	Wall	Skid	Skid
Electrical	120V/60Hz/ 1Phase	120V/60Hz/ 1Phase	120V/60Hz/ 1Phase	120V/60Hz/ 1Phase	120V/60Hz/ 1Phase	120V/60Hz/ 1Phase	120V/60Hz/ 1Phase
Amperage	20	20	8	8	8	8	8
Compressed Air SCFM Required	Integrated ³	Integrated ³	3.2	6.0	10.5	15.0	23.0
Air Compressor Min. Working Pressure	Integrated ³	Integrated ³	120 PSI	120 PSI	120 PSI	120 PSI	120 PSI
Compatible Air Compressor Packages (STS-NF-C-)	Integrated ³	Integrated ³	2-J, 3-J 4-CH, 5-CH 6-CH	3-J 4-CH, 5-CH 6-CH, 7-CH	4-CH, 5-CH, 6-CH, 7-CH	5-CH, 6-CH 7-CH	6-CH, 7-CH
N₂ Receiver Tank Size	28 Gallons	16.8 Gallons	28 Gallons	28 Gallons	28 Gallons	80 Gallons	80 Gallons
Maintenance	Annual	Annual	Annual	Annual	Annual	Annual	Annual
Lead Time	1-2 Weeks	1-2 Weeks	1-2 Weeks	1-2 Weeks	1-2 Weeks	1-2 Weeks	1-2 Weeks
Warranty	1 Year ⁴	1 Year ⁴	1 Year ⁴	1 Year ⁴	1 Year ⁴	1 Year ⁴	1 Year ⁴

¹The combined weight of the Nitrogen Generator and Receiver/Buffer Tank.

²Wall mount can be provided with floor stand.

³The FPS-650 & FPS-1250 systems are complete with integrated air compressors. A separate air compressor can be provided by South-Tek or a pre-existing air compressor can be utilized to fill largest zone to pressure within 30 minutes (per NFPA 13 req.).

⁴Per South-Tek Systems' Terms & Conditions.



Data Acquisition System (DAS) Certified

South-Tek Systems guarantees that every N₂-Blast[®] Nitrogen generator meets or exceeds the requested specifications with a third party DAS Certification. It logs data such as the exact air flow and pressure in, as well as the Nitrogen flow, pressure and purity out. Ensuring that each N₂-Blast[®] Nitrogen generator purchased yields high performance and 98%+ Nitrogen purity.

FEED AIR COMPRESSOR SPECIFICATIONS

	STS-NF-C-2-J	STS-NF-C-3-J	STS-NF-C-4-CH	STS-NF-C-5-CH	STS-NF-C-6-CH	STS-NF-C-7-CH
Horsepower	1	2	3	5	7.5	10
SCFM	3.8	7.6	10.9	17.3	23.1	34.8
Min. Working Pressure	120 PSI	120 PSI	125 PSI	125 PSI	125 PSI	125 PSI
Zone Capacity Filled w/in 30 Min. (40 PSI)	575 Gallons	900 Gallons	1,100 Gallons	1,600 Gallons	2,100 Gallons	2,800 Gallons
Air Compressor Dimensions (W x L x H)	16"x27"x57"	16"x27"x57"	24"x31"x76"	25"x33"x76"	26"x34"x76"	43"x30"x81"
Air Compressor Weight	250 lbs.	250 lbs.	425 lbs.	545 lbs.	665 lbs.	890 lbs.
Air Compressor Electric (Single Phase)	120-208-230V 60Hz	120-208-230V 60Hz	115-208-230V 60Hz	208-230V 60Hz	208-230V 60Hz	n/a
Air Compressor Electric (Three Phase)	208-230-460V 60Hz	208-230-460V 60Hz	200-230-460V 60Hz	200-230-460V 60Hz	200-230-460V 60Hz	200-230-460V 60Hz
Refrigerated Dryer Dimensions (W x L x H)	9"x16"x20"	9"x16"x20"	11"x18"x20"	11"x18"x20"	21"x18"x26"	21"x18"x26"
Refrigerated Dryer Weight	40 lbs.	40 lbs.	55 lbs.	55 lbs.	57 lbs.	57 lbs.
Refrigerated Dryer Electric	115V/60Hz 1Ph 11 AMP	115V/60Hz 1Ph 11 AMP	115V/60Hz 1Ph 13 AMP	115V/60Hz 1Ph 13 AMP	115V/60Hz 1Ph 13 AMP	115V/60Hz 1Ph 13 AMP
Warranty	1 Year ¹	1 Year ¹	5 Years ¹	5 Years ¹	5 Years ¹	5 Years ¹

¹Per Manufacturer's Terms & Conditions.



South-Tek Systems Warranties

WE DESIGN BEST IN CLASS, DEPENDABLE NITROGEN GENERATION SYSTEMS. IT ONLY SEEMS RIGHT TO OFFER A WARRANTY TO MATCH.



N₂-Blast® Nitrogen Generators¹

South-Tek Systems warrants to the purchaser that all Nitrogen generators and other products manufactured by South-Tek Systems shall be free of defects in material and workmanship for a period of one (1) year from the date of shipment to the purchaser or within 1,000 hours of runtime, whichever comes first (per South-Tek Systems' Terms & Conditions). The South-Tek Systems warranty only applies to products manufactured by South-Tek Systems.

STS-NF-C-2/3-J Series Air Compressor Packages²

The STS-NF-C-J Series Air Compressor Packages are warranted for one (1) year from date of purchase. The manufacturer will repair, without charge, any defects due to faulty materials or workmanship. This warranty does not apply to accessories or damage caused where repairs have been made or attempted by others.

STS-NF-C-4/5/6/7-CH Series Air Compressor Packages²

Each new assembled STS-NF-C-4-CH, 5-CH, 6-CH and 7-CH has a five (5) year warranty on the compressor pump only, against defects in materials or workmanship under normal use and service, from the date of installation or sixty-six (66) months from the date of shipment by the manufacturer or a manufacturer's distributor, whichever may occur first. The five-year extended warranty covers parts and labor and is prorated over the five years as follows:

- Year One — 100% coverage
- Year Two — 90% coverage
- Year Three — 80% coverage
- Year Four — 70% coverage
- Year Five — 60% coverage

Head valves are warranted for Year One only. The manufacturer makes no warranty on components and/or accessories furnished to the manufacturer by third parties, such as electric motors, gasoline engines and controls. These are warranted only to the extent of the original manufacturer's warranty to the manufacturer. Includes a five-year warranty on the air receiver, pump and motor.

RD Series Air Dryer Packages²

The RD Series Air Dryer Packages have a one (1) year warranty against defects in materials or workmanship under normal use and service, from the date of installation or eighteen (18) months from the date of shipment by the manufacturer or a manufacturer's distributor, whichever may occur first. Heat Exchangers are warranted for five (5) years.

¹Per South-Tek Systems' Terms and Conditions

²Per the Manufacturer's Terms and Conditions



www.southteksystems.com
commercialsales@southteksystems.com
 888.526.6284

