

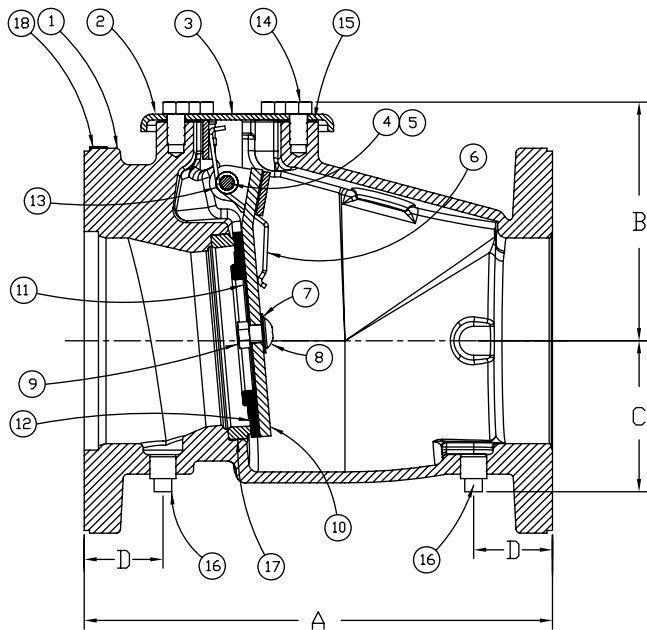

REPLACEMENT PARTS

SWING CHECK VALVE MODEL F-2 VDS

Manufactured 2004 -



SIZE	A	B	C	D
3" (DN 80)	9-1/2" (241,3)	4-3/4" (120,7)	2-3/4" (69,9)	2-1/4" (57,2)
4" (DN 100)	10-5/8" (269,9)	5-3/16" (131,8)	3-3/8" (85,7)	2-1/4" (57,2)
6" (DN 150)	13-5/8" (346,1)	6-3/4" (171,5)	4-3/8" (111,1)	2-1/4" (57,2)
8" (DN 200)	17" (431,8)	8-3/4" (222,3)	5-3/8" (136,5)	2-7/8" (73,0)

Dimensions shown in parentheses are millimeter.
Dimensions are approximate.

* For availability of Flanged-Flanged or Grooved-Grooved options, refer to Table 1.

ITEM NO.	PART NUMBERS				DESCRIPTION	MATERIAL	NO. REQ'D			
	3" (DN80)	4" (DN100)	6" (DN150)	8" (DN200)			3"	4"	6"	8"
1	--	--	--	--	Body	Ductile Iron, 65-45-12	1	1	1	1
2	--	--	--	--	Cover Assembly	ASTM A715 Grade 50 HSLA Steel and Stainless Steel UNS-S30400	1	1	1	1
3	--	--	--	--	Plate, Data	Aluminum Etched	1	1	1	1
4	05355A	04900A	04991A	05334A	Pin, Hinge	Stainless Steel UNS-S30400	1	1	1	1
5	05445A	05445A	05445A	05334A	Ring, Retaining	Stainless Steel UNS-S15700	2	2	2	2
6	06021B	05939B	05940B	05952B	Spring, Torsion	Stainless Steel UNS-30200	1	1	1	1
7	08158	08158	08143	08143	Washer, Sealing	Stainless Steel & EPDM	1	1	1	1
8	10194	10194	10308	10686	Screw	Stainless Steel UNS-S30400	1	1	1	1
9	08159	08159	08144	08144	Nut	Stainless Steel UNS-S30400	1	1	1	1
10	*	*	*	*	Clapper	HR Steel UNS-G10180	1	1	1	1
11	*	*	*	*	Retainer	Stainless Steel UNS-S30400	1	1	1	1
12	*	*	*	*	Rubber	EPDM ASTM D2000	1	1	1	1
13	07576	07576	07576	--	Bushing	Lubricomp 189 Ryton w/Celanese PPS Resin	2	2	2	--
14	01517A	01517A	--	--	Screw, H.H.C. 3/8-16 x 3/4 Lg.	Steel, SAE Grade 2, ASTM A307, Zinc Plated	4	6	--	--
	--	--	04993A	--	Screw, H.H.C. 1/2-13 x 7/8 Lg.	Steel, SAE Grade 5, ASTM A449	--	--	6	--
	--	--	--	01922A	Screw, H.H.C. 5/8-11 x 1-1/4 Lg.	Steel, SAE Grade 2, ASTM A307, Zinc Plated	--	--	--	6
15	05354B	04649B	04992B	05339C	Gasket, Cover	Black EPDM, ASTM D2000	1	1	1	1
16	--	--	--	--	Plug, Pipe 1/2" NPT	Steel	2	2	2	2
17	--	--	--	--	Seat	Brass, UNS-C84400	1	1	1	1
18	--	--	--	--	Plate, PN10/16 Flange Ident.	Aluminum	2	2	2	--
	--	--	--	--	Plate, PN10 Flange Ident.	Aluminum	--	--	--	2
	--	--	--	--	Plate, PN16 Flange Ident.	Aluminum	--	--	--	2

-- Indicates part is not available

* Indicates part is available in a Sub-Assembly only--see Sub-Assembly list.

SUB-ASSEMBLIES AVAILABLE

7-13	09916	09398	09421	09917	Clapper Assembly
7-9, 11,12,15	09912	09913	09914	09915	Replacement Rubber Kit