



TECHNICAL DATA

MODEL VFC FOAM CHAMBERS

The Viking Corporation, 210 N Industrial Park Drive, Hastings MI 49058

Telephone: 269-945-9501 Technical Services: 877-384-5464 Fax: 269-818-1680 Email: techsvcs@vikingcorp.com

Visit the Viking website for the latest edition of this technical data page.

1. GENERAL DESCRIPTION

Foam Chambers are suitable for the protection of fixed roof-mounted tanks and are to be used as low expansion Type II discharge devices (as defined by NFPA11) with approved and/or listed Foam Concentrates and Proportioning Devices.

Foam Chambers are designed to apply an expanded foam blanket over the surface of a flammable liquid fire as gently as possible to achieve extinguishment and/or vapor suppression. A deflector positioned on the inside of the storage tank directs the expanded foam back onto the wall of the tank. The foam runs down the wall of the tank onto the liquid surface, minimizing submergence and fuel pick-up thereby maximizing the positive effect of the foam.

Low Expansion Foam Deluge Systems are the preferred protection for large outdoor tanks of flammable liquids. Typical applications include manufacturing plants, large tank farms, oil refineries and chemical plants.

NOTE: *The information in this document is subject to change without notice.*

2. LISTINGS AND APPROVALS

The Foam Chamber is FM Approved and UL Listed as part of a fire extinguishing system combining designated foam concentrates, proportioning devices and bladder tanks. Approved and Listed system components can be found at <https://iq.ulprospector.com>



FM Approved - Low Expansion Foam Systems (FM5130)



UL Listed – GHXV.EX5194

“SFFF compatible” refers to this product as being part of a SFFF Foam system that has been tested to recognized standards. Not all configurations are available. Please consult technical data and/or the Approval/Listing for usage requirements.

NOTE: *Other International approval certificates may be available upon request.*

3. TECHNICAL DATA

3.1 Construction Features

- Available in 2.5”, 3”, 4”, 6” sizes to cover a wide range of design configurations
NOTE: *The 6” size is UL listed only.*
- Painted Carbon Steel or Painted Stainless Steel for increased corrosion protection
- Available with ANSI 150 or PN16 Flanges
- Lifting lug/handle to assist with installation and servicing
- Choice of 2 Deflectors: Solid and Split (For installation from outside of storage tank)
- Specifically FM Approved and UL Listed with Viking Foam Concentrates.



WARNING: Cancer and Reproductive Harm-
www.P65Warnings.ca.gov



SFFF
compatible



TECHNICAL DATA

MODEL VFC FOAM CHAMBERS

The Viking Corporation, 210 N Industrial Park Drive, Hastings MI 49058

Telephone: 269-945-9501 Technical Services: 877-384-5464 Fax: 269-818-1680 Email: techsvcs@vikingcorp.com

Visit the Viking website for the latest edition of this technical data page.

3.2 Standard Materials

Table 3.2.1 - Standard Materials

	Carbon Steel Version	Stainless Steel Version
Body	Carbon Steel ASME SA-106 Gr.B / EN P265GH	Stainless Steel ASME SA-182 F316 / EN 1.4401 AISI-316
Flanges (ANSI 150 or PN16)	Carbon Steel ASME SA-105 / EN P245GH	Stainless Steel ASME SA-182 F316 / EN 1.4401 AISI-316
Vapor seal	Aluminium	Aluminium
Calibrated orifice material	Stainless Steel UNS-S30400	Stainless Steel UNS-S30400 / ASME SA-182 F316 / EN 1.4401 AISI-316
Paint	Epoxy zinc-rich primer with aliphatic polyurethane finish	Epoxy zinc rich primer with aliphatic polyurethane finish
Standard color	RAL3000 Red	RAL3000 Red
Inlet Flange Gasket	Composite	Composite

3.3 Standard Design Specifications

Table 3.3.1 - Standard Design Specifications

Model	Inlet Size	Working Pressure ¹				Flow Range				Orifice Range		Approval ²
		Minimum		Maximum		Minimum		Maximum		Inches	mm	
		PSI	bar	PSI	bar	GPM	LPM	GPM	LPM			
VFC	2.5"	30	2.07	125	8.61	36	137	226	855	0.600 – 1.050	15 – 27	FM/UL
	3"	30	2.07	125	8.61	82	312	480	1818	0.906 – 1.531	23 – 39	FM/UL
	4"	30	2.07	125	8.61	131	496	740	2800	1.142 – 1.900	29 – 48	FM/UL
	6"	30	2.07	125	8.61	362	1372	1261	4774	1.900 – 2.481	48 – 63	UL

Footnotes:

¹ Working pressure at the inlet orifice of the foam chamber.

² Please refer to www.approvalguide.com for specific approval data. Note that approved Working Pressures and Flow Ranges are specific to the tested foam concentrate.

³ Please refer to <https://iq.ulprospector.com> for specific listing details.

3.3.1 Determining Orifice Size

After determining the required foam flow rate and available pressure, the orifice must be sized using the following formula:

$$d = \left(\frac{Q}{18.327 \cdot P^{1/2}} \right)^{1/2}$$

d = Orifice Ø (in.)
 Q = Solution Flow Rate (GPM)
 P = Pressure at orifice inlet (PSI)

3.3.2 Vapor Seal

Vapor Seal burst pressure is 10-25 psi (0.69 - 1.72 bar) measured just upstream of inlet orifice. Maximum allowable backpressure is 2 psi (0.14 bar).



TECHNICAL DATA

MODEL VFC FOAM CHAMBERS

The Viking Corporation, 210 N Industrial Park Drive, Hastings MI 49058

Telephone: 269-945-9501 Technical Services: 877-384-5464 Fax: 269-818-1680 Email: techsvcs@vikingcorp.com

Visit the Viking website for the latest edition of this technical data page.

3.4 Ordering Information

Inlet orifice plate(s) are manufactured according to your specific project requirements. The following steps should be followed to ensure the correct order processing information is specified.

1. Use the tables in section 7 (Performance Data) to determine what size Foam Chamber will satisfy the flow and pressure requirements for your specific project. (Required)
2. Check the FM Approval and/or UL Listing for the specific foam concentrate model to ensure the inlet pressure, orifice size and fuel type is listed. (Required)
3. Select the Foam Chamber size, flange pattern and material from table 3.4.1. (Required)

NOTE: The Foam Chamber part number from this table is used at the quotation stage only for the Americas ordering territory.

4. Select a Split or Solid Deflector with the flange pattern that matches the outlet flange pattern of the Foam Chamber. (Required)
5. If required, select the Mounting Flange with the flange pattern that matches the outlet flange pattern of the Foam Chamber. (Optional)
6. The Foam Chamber is either supplied with a vapor seal already installed or as part of a kit which includes orifices and flange gaskets. If spare vapor seals are required then refer to table 13.1.1. (Recommended)
7. When the official purchase order is made for a Foam Chamber, the Foam Chamber size, orifice inlet pressure and desired flow rate must be provided. Please use the Foam Chamber order form (F_061217A) to ensure your order is processed correctly (Required)

NOTE: The inlet orifice size will be manufactured to match the pressure and flow information that you provide in step 7. The final (ordering) part number for the Americas ordering territory will be the base part number for the Foam Chamber and a serialized suffix.

Refer to your customer service representative for further information and order form.

Table 3.4.1 Ordering Information

Description	Material	Finish	Base Part Number		Weight	
			ANSI 150	PN16	Lbs.	Kg
2.5" Foam Chamber	Carbon Steel	Painted	F20904	F20905	76.3	34.6
Split Deflector	Carbon Steel	Painted	F20941	F20943	4.2	1.9
Solid Deflector	Carbon Steel	Painted	F20937	F20939	4.2	1.9
4" Mounting flange with studs	Carbon Steel	Painted	F20919	F20920	11.9	5.4
2.5" Foam Chamber	Stainless Steel 316	Painted	F20906	F20907	99.0	44.9
Split Deflector	Stainless Steel 316	Painted	F20942	F20944	4.4	2.0
Solid Deflector	Stainless Steel 316	Painted	F20938	F20940	4.4	2.0
4" Mounting flange with studs	Stainless Steel 316	Painted	F20921	F20922	12.5	5.7
3" Foam Chamber	Carbon Steel	Painted	F21203	F21204	108.9	49.4
Split Deflector	Carbon Steel	Painted	F21169	F21171	8.6	3.9
Solid Deflector	Carbon Steel	Painted	F21157	F21159	8.6	3.9
6" Mounting flange with studs	Carbon Steel	Painted	F21181	F21182	16.8	7.6
3" Foam Chamber	Stainless Steel	Painted	F21205	F21206	153.2	69.5
Split Deflector	Stainless Steel	Painted	F21170	F21172	9.0	4.1
Solid Deflector	Stainless Steel	Painted	F21158	F21160	9.0	4.1
6" Mounting flange with studs	Stainless Steel	Painted	F21183	F21184	17.6	8.0
4" Foam Chamber	Carbon Steel	Painted	F21207	F21208	150.6	68.3
Split Deflector	Carbon Steel	Painted	F21173	F21175	13.7	6.2
Solid Deflector	Carbon Steel	Painted	F21161	F21163	13.7	6.2
8" Mounting flange with studs	Carbon Steel	Painted	F21185	F21186	21.4	9.7
4" Foam Chamber	Stainless Steel	Painted	F21209	F21210	212.1	96.2
Split Deflector	Stainless Steel	Painted	F21174	F21176	14.4	6.5
Solid Deflector	Stainless Steel	Painted	F21162	F21164	14.4	6.5
8" Mounting flange with studs	Stainless Steel	Painted	F21187	F21188	22.5	10.2
6" Foam Chamber	Carbon Steel	Painted	F21211	F21212	288.6	130.9
Split Deflector	Carbon Steel	Painted	F21177	F21179	17.9	8.1
Solid Deflector	Carbon Steel	Painted	F21165	F21167	17.9	8.1
10" Mounting flange with studs	Carbon Steel	Painted	F21189	F21190	35.9	16.3
6" Foam Chamber	Stainless Steel	Painted	F21213	F21214	412.9	187.3
Split Deflector	Stainless Steel	Painted	F21178	F21180	18.8	8.5
Solid Deflector	Stainless Steel	Painted	F21166	F21168	18.8	8.5
10" Mounting flange with studs	Stainless Steel	Painted	F21191	F21192	37.7	17.1



TECHNICAL DATA

MODEL VFC FOAM CHAMBERS

The Viking Corporation, 210 N Industrial Park Drive, Hastings MI 49058

Telephone: 269-945-9501 Technical Services: 877-384-5464 Fax: 269-818-1680 Email: techsvcs@vikingcorp.com

Visit the Viking website for the latest edition of this technical data page.

4. SCOPE OF DELIVERY

Ensure that all components are complete and in good condition.

Includes:

- Foam Chamber
- Sized Orifice (Quantity 1)
- Vapor Seal (Quantity 1)
- Inlet Flange Gaskets (Quantity 2)
- Lifting lug to allow safe maneuverability on site.

Not Included

- Tank Mounting Flange (Sold Separately – see table 3.4.1)
- Split/Solid Deflector (Sold Separately – see table 3.4.1)

5. AVAILABILITY

The product is available directly from Viking and official distributors only.

Americas:

The Viking Corporation
5150 Beltway SE
Caledonia, MI 49316
Tel.: (800) 968-9501
Fax: 269-818-1680
Technical Services: 1-877-384-5464
techsvcs@vikingcorp.com

EMEA:

Viking S.A.
21, Z.I, Haneboesch
L-4562 Differdange / Nieder Korn
Tel.: +352 58 37 37 – 1
Fax: +352 58 37 36
vikinglux@viking-emea.com

Asia Pacific (APAC) Main Office:

The Viking Corporation (Far East) Pte. Ltd.
69 Tuas View Square
Westlink Techpark, Singapore 637621
Tel: (+65) 6 278 4061
Fax: (+65) 6 278 4609
vikingAPAC@vikingcorp.com

6. PRODUCT VARIANTS

6.1 Options

- Also available with Galvanized or Paint over Galvanized Finish (Not FM Approved or UL Listed)
- Various Colors
- Internal Paint



TECHNICAL DATA

MODEL VFC FOAM CHAMBERS

The Viking Corporation, 210 N Industrial Park Drive, Hastings MI 49058
 Telephone: 269-945-9501 Technical Services: 877-384-5464 Fax: 269-818-1680 Email: techsvcs@vikingcorp.com
 Visit the Viking website for the latest edition of this technical data page.

6.2 Dimensions: Foam Chambers

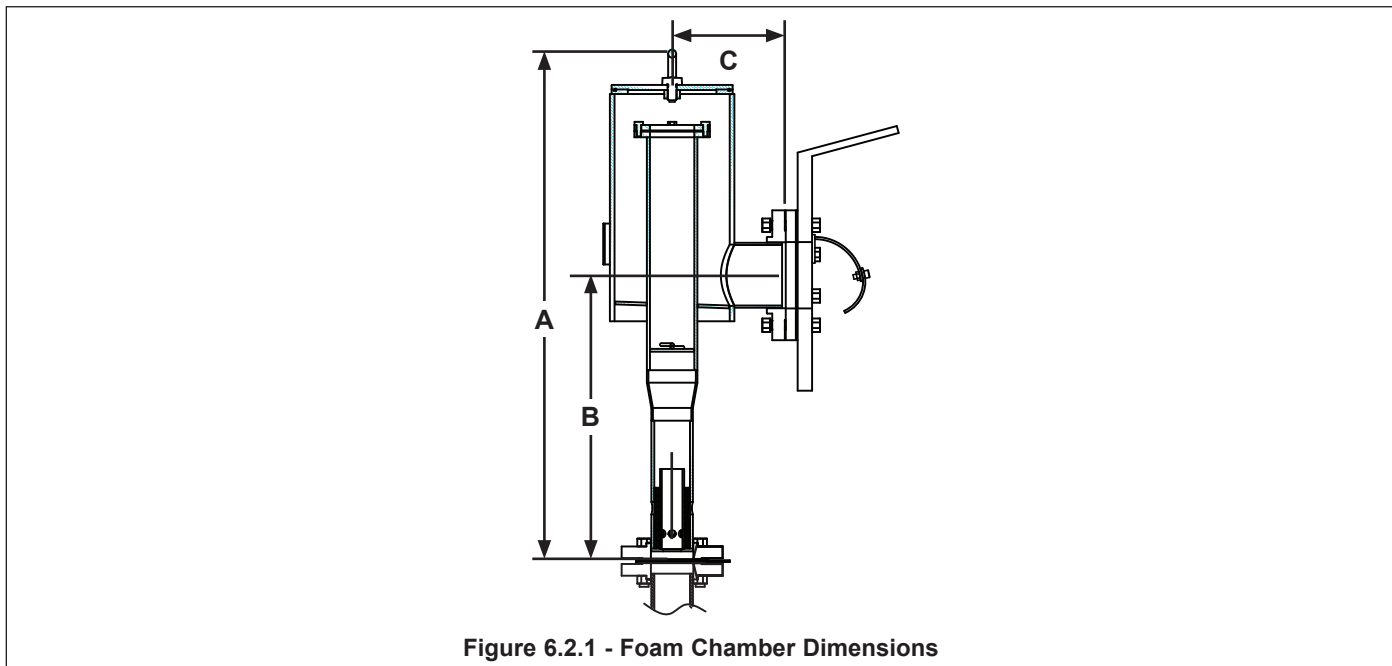

Figure 6.2.1 - Foam Chamber Dimensions

Table 6.2.2 - Foam Chamber Dimensions

Part Number	Foam Chamber/ Inlet Flange Size	Outlet Flange Size	Material	Mounting Flange Style	A		B		C	
					In.	mm	In.	mm	In.	mm
F20904	2-1/2"	4"	Steel	ANSI	35 1/4	897	19 5/8	500	7 7/8	200
F20905			Steel	PN16						
F20906			Stainless Steel	ANSI						
F20907			Stainless Steel	PN16						
F21203	3"	6"	Steel	ANSI	40 3/8	1025	23 3/8	600	9 7/8	250
F21204			Steel	PN16						
F21205			Stainless Steel	ANSI						
F21206			Stainless Steel	PN16						
F21207	4"	8"	Steel	ANSI	41 1/8	1046	25 1/2	650	11 7/8	300
F21208			Steel	PN16						
F21209			Stainless Steel	ANSI						
F21210			Stainless Steel	PN16						
F21211	6"	10"	Steel	ANSI	54 1/2	1386	30	760	14	355
F21212			Steel	PN16						
F21213			Stainless Steel	ANSI						
F21214			Stainless Steel	PN16						



TECHNICAL DATA

MODEL VFC FOAM CHAMBERS

The Viking Corporation, 210 N Industrial Park Drive, Hastings MI 49058
 Telephone: 269-945-9501 Technical Services: 877-384-5464 Fax: 269-818-1680 Email: techsvcs@vikingcorp.com
 Visit the Viking website for the latest edition of this technical data page.

6.3 Dimensions: Deflectors

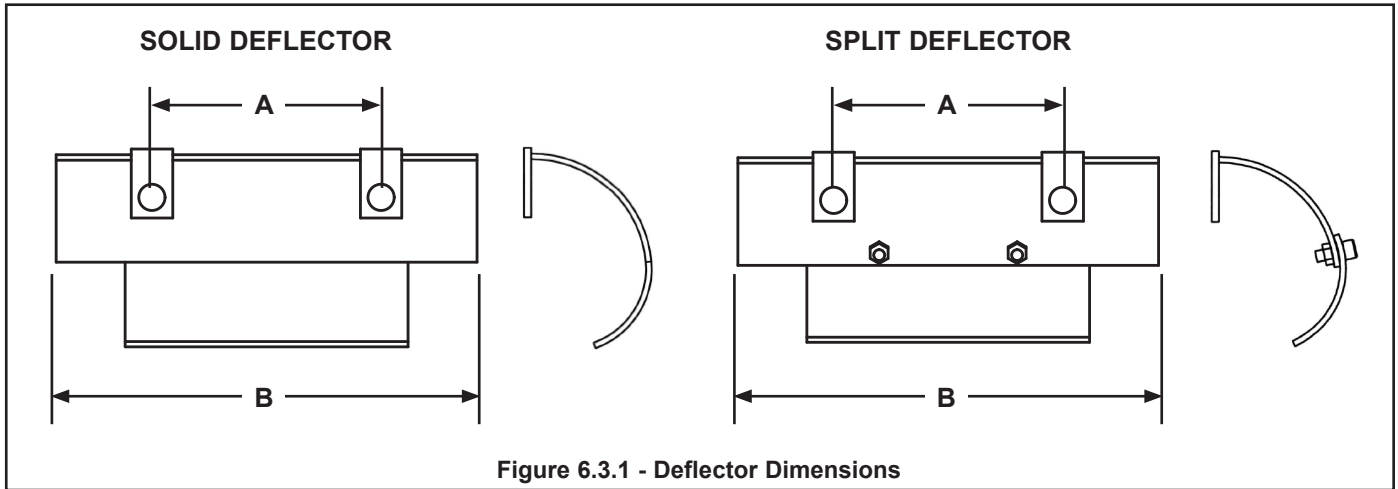



Figure 6.3.1 - Deflector Dimensions

Table 6.3.2 - Deflector Dimensions

Part Number	Foam Chamber Size	Style	A		B		Weight	
			Inches	mm	Inches	mm	LB	KG
F20937	2-1/2"	SOLID	6 ⁵ / ₈	176	12	305	4.19	1.90
F20939			6 ¹ / ₂	166			4.19	1.90
F20938			6 ⁵ / ₈	176			4.40	2.00
F20940			6 ¹ / ₂	166			4.40	2.00
F21157	3"		8 ³ / ₄	223	18 ¹ / ₂	460	8.60	3.90
F21158			8 ³ / ₄	222			9.03	4.10
F21159			8 ³ / ₄	223			8.60	3.90
F21160	4"		8 ³ / ₄	222	24	610	9.03	4.10
F21161			10 ⁷ / ₈	276			13.67	6.20
F21162			7 ³ / ₄	198			14.35	6.51
F21163			10 ⁷ / ₈	276			13.67	6.20
F21164	6"		7 ³ / ₄	198	25 ¹ / ₂	650	14.35	6.51
F21165			10	256			17.86	8.10
F21166			9 ³ / ₄	251			18.75	8.51
F21167			10	256			17.86	8.10
F21168	9 ³ / ₄		251	18.75	8.51			
F20941	2-1/2"	SPLIT	7	176	12	305	4.19	1.90
F20943			6 ¹ / ₂	166			4.19	1.90
F20942			7	176			4.40	2.00
F20944			6 ¹ / ₂	166			4.40	2.00
F21169	3"		8 ³ / ₄	223	18 ¹ / ₂	460	8.60	3.90
F21170			8 ³ / ₄	222			9.03	4.10
F21171			8 ³ / ₄	223			8.60	3.90
F21172	4"		8 ³ / ₄	222	24	610	9.03	4.10
F21173			10 ⁷ / ₈	276			13.67	6.20
F21174			7 ³ / ₄	198			14.35	6.51
F21175			10 ⁷ / ₈	276			13.67	6.20
F21176	6"		7 ³ / ₄	198	25 ¹ / ₂	650	14.35	6.51
F21177			10	256			17.86	8.10
F21178			9 ³ / ₄	251			18.75	8.51
F21179			10	256			17.86	8.10
F21180	9 ³ / ₄		251	18.75	8.51			



TECHNICAL DATA

MODEL VFC FOAM CHAMBERS

The Viking Corporation, 210 N Industrial Park Drive, Hastings MI 49058
 Telephone: 269-945-9501 Technical Services: 877-384-5464 Fax: 269-818-1680 Email: techsvcs@vikingcorp.com
 Visit the Viking website for the latest edition of this technical data page.

7. PERFORMANCE DATA

Table 7.1

FM Approvals: Heptane ^{1,4}														
Foam Concentrate	Inlet Size	Working Pressure ¹				Flow Range				Orifice Range		Minimum Listed Foam Design Density		Graph Reference
		Minimum		Maximum		Minimum		Maximum						
		PSI	bar	PSI	bar	GPM	LPM	GPM	LPM	Inches	mm	gpm/ft ²	Lpm/m ²	
ARK 3%	2.5"	40	3	125	9	43	163	226	856	0.600 – 1.050	15 – 27	0.20	8.2	7.1.1
	3"	40	3	125	9	96	363	480	1817	0.906 – 1.531	23 – 39	0.20	8.2	7.1.2
	4"	40	3	125	9	154	583	740	2801	1.142 – 1.900	29 – 48	0.20	8.2	7.1.3
USP 3%	3"	75	5	75	5	132	500	372	1408	0.906 – 1.531	23 – 39	0.10	4.1	7.1.4

Footnotes:

1. This table shows approvals available at the time of publication.
2. Density indicated is minimum application density required per FM5130 Standard for Foam Equipment and Liquid Concentrates. This density cannot be reduced.
3. Working pressure on the upstream side of the inlet orifice of the foam chamber.
4. Refer to the graphs below for design range.

Graph 7.1.1

2.5" Model VFC With Viking ARK 3% | FM | Heptane

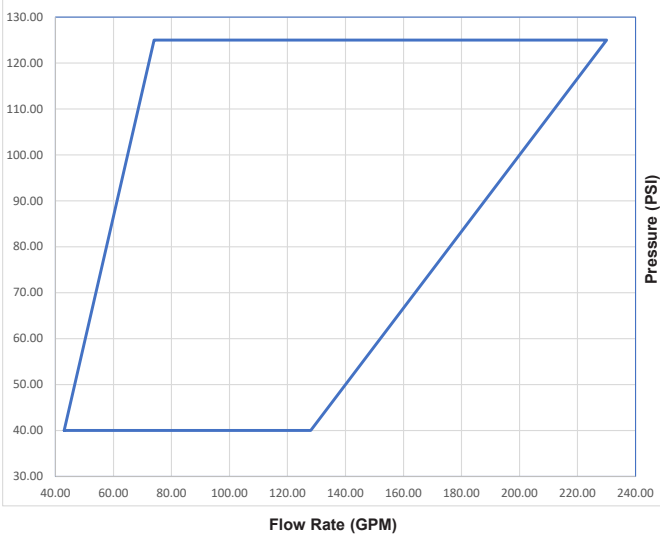

Graph 7.1.2

3" Model VFC With Viking ARK 3% | FM | Heptane

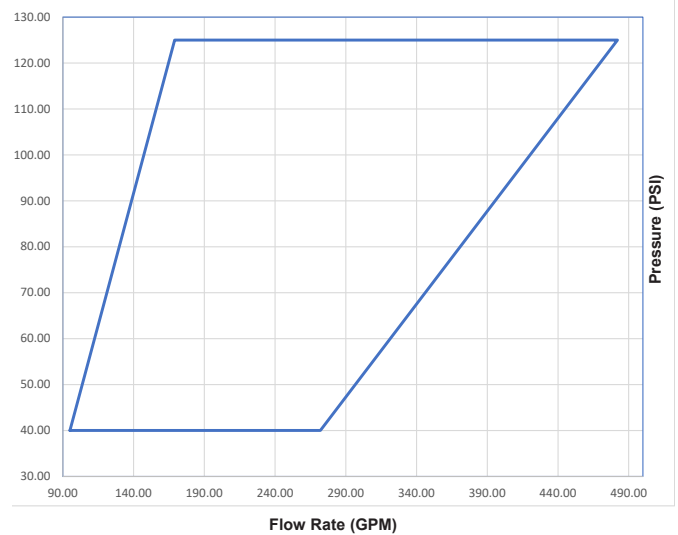



TECHNICAL DATA

MODEL VFC FOAM CHAMBERS

The Viking Corporation, 210 N Industrial Park Drive, Hastings MI 49058
Telephone: 269-945-9501 Technical Services: 877-384-5464 Fax: 269-818-1680 Email: techsvcs@vikingcorp.com
Visit the Viking website for the latest edition of this technical data page.

Graph 7.1.3
4" Model VFC With Viking ARK 3% | FM | Heptane

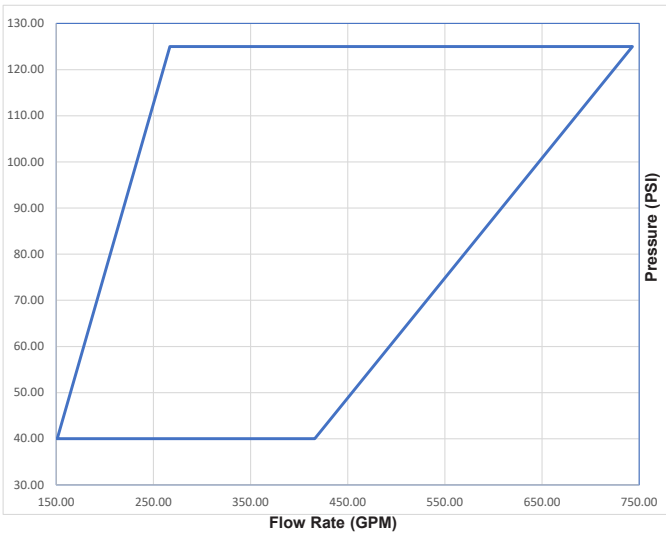

Graph 7.1.4
3" Model VFC With Viking USP 3% | FM | Heptane

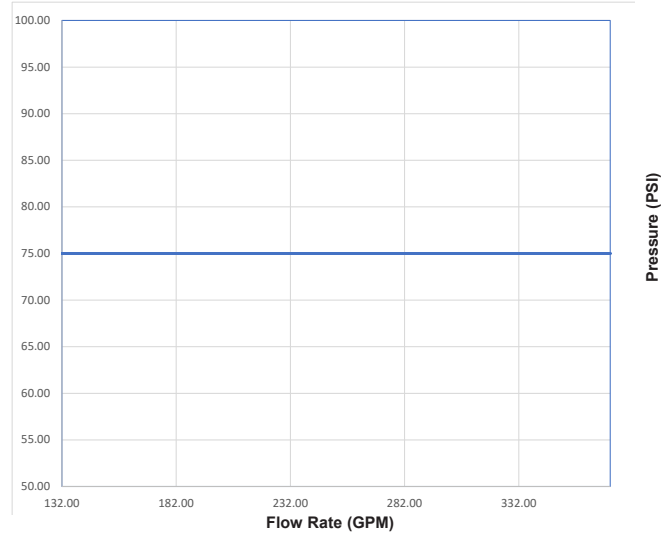



TECHNICAL DATA

MODEL VFC FOAM CHAMBERS

The Viking Corporation, 210 N Industrial Park Drive, Hastings MI 49058
 Telephone: 269-945-9501 Technical Services: 877-384-5464 Fax: 269-818-1680 Email: techsvcs@vikingcorp.com
 Visit the Viking website for the latest edition of this technical data page.

Table 7.2

FM Approvals: IPA ^{1,4}														
Foam Concentrate	Inlet Size	Working Pressure ¹				Flow Range				Orifice Range		Minimum Listed Foam Design Density		Graph Reference
		Minimum		Maximum		Minimum		Maximum		Inches	mm	gpm/ft ²	Lpm/m ²	
		PSI	bar	PSI	bar	GPM	LPM	GPM	LPM					
ARK 3%	2.5"	40	3	125	9	43	163	226	856	0.600 – 1.050	15 – 27	0.25	10.2	7.2.1
	3"	40	3	125	9	96	363	480	1817	0.906 – 1.531	23 – 39	0.25	10.2	7.2.2
	4"	40	3	125	9	154	583	740	2801	1.142 – 1.900	29 – 48	0.25	10.2	7.2.3

Footnotes:

1. This table shows approvals available at the time of publication.
2. Density indicated is minimum application density required per FM5130 Standard for Foam Equipment and Liquid Concentrates. This density cannot be reduced.
3. Working pressure on the upstream side of the inlet orifice of the foam chamber.
4. Refer to the graphs below for design range.

Graph 7.2.1
 2.5" Model VFC With Viking ARK 3% | FM | IPA

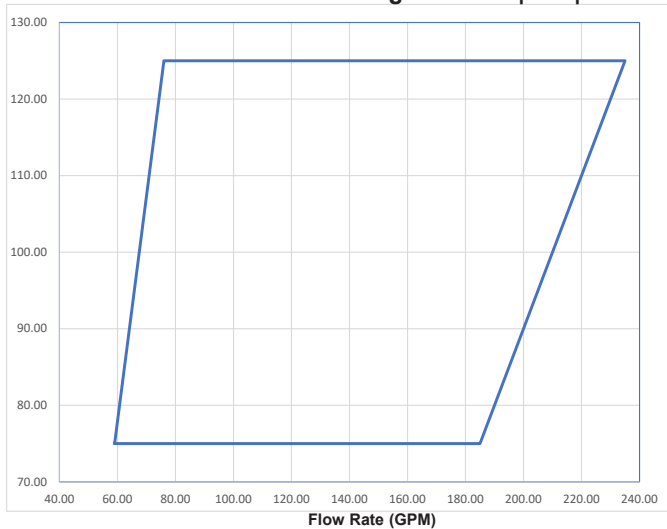

Graph 7.2.2
 3" Model VFC With Viking ARK 3% | FM | IPA

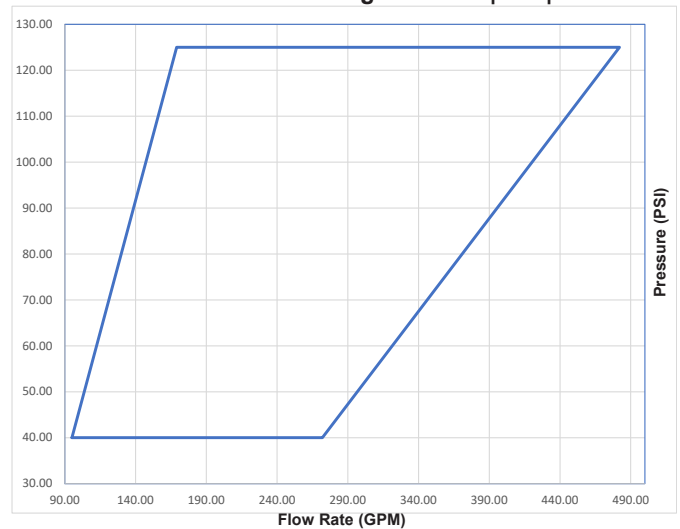

Graph 7.2.3
 4" Model VFC With Viking ARK 3% | FM | IPA

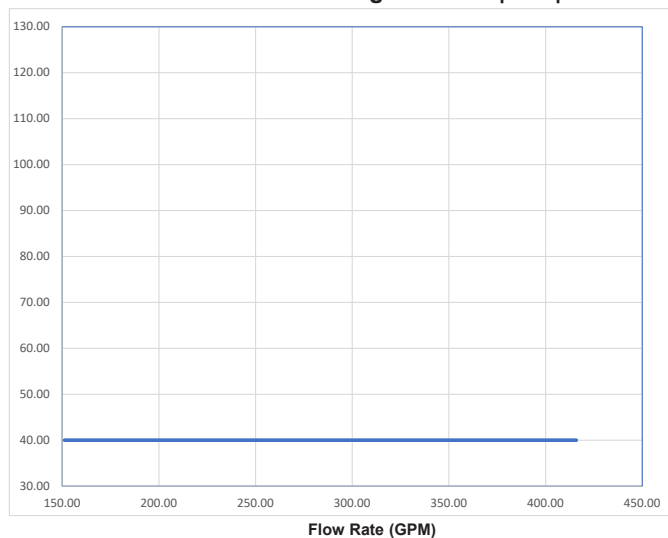



TECHNICAL DATA

MODEL VFC FOAM CHAMBERS

The Viking Corporation, 210 N Industrial Park Drive, Hastings MI 49058
 Telephone: 269-945-9501 Technical Services: 877-384-5464 Fax: 269-818-1680 Email: techsvcs@vikingcorp.com
 Visit the Viking website for the latest edition of this technical data page.

Table 7.3

FM Approvals: Acetone ^{1,4}														
Foam Concentrate	Inlet Size	Working Pressure ¹				Flow Range				Orifice Range		Minimum Listed Foam Design Density		Graph Reference
		Minimum		Maximum		Minimum		Maximum		Inches	mm	gpm/ft ²	Lpm/m ²	
		PSI	bar	PSI	bar	GPM	LPM	GPM	LPM					
ARK 3%	2.5"	40	3	125	9	43	163	226	856	0.600 – 1.050	15 – 27	0.20	8.2	7.3.1
	3"	40	3	125	9	96	363	480	1817	0.906 – 1.531	23 – 39	0.20	8.2	7.3.2
	4"	40	3	40	3	154	583	415	1571	1.142 – 1.900	29 – 48	0.20	8.2	7.3.3

Footnotes:

1. This table shows approvals available at the time of publication.
2. Density indicated is minimum application density required per FM5130 Standard for Foam Equipment and Liquid Concentrates. This density cannot be reduced.
3. Working pressure on the upstream side of the inlet orifice of the foam chamber.
4. Refer to the graphs below for design range.

Graph 7.3.1

2.5" Model VFC With Viking ARK 3% | FM | ACETONE

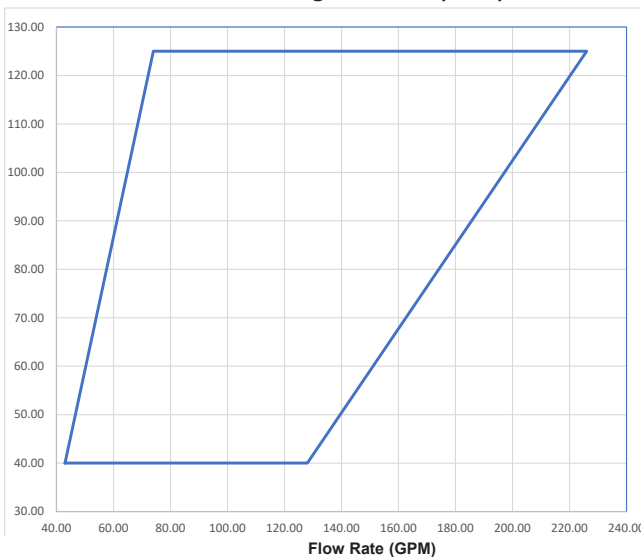

Graph 7.3.2

3" Model VFC With Viking ARK 3% | FM | ACETONE

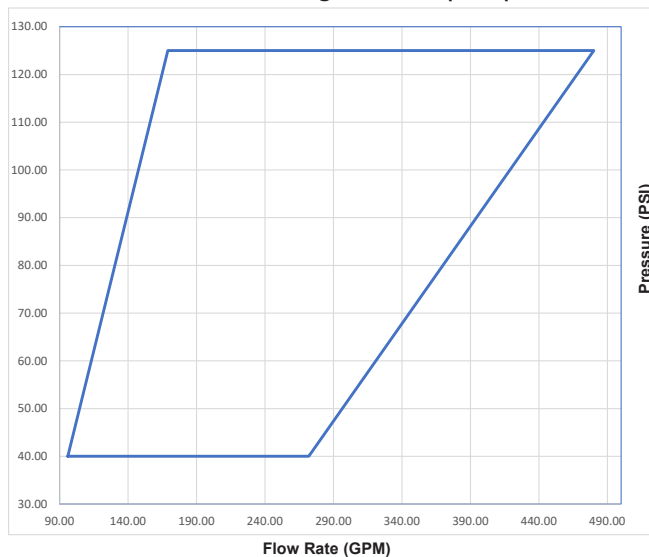

Graph 7.3.3

4" Model VFC With Viking ARK 3% | FM | ACETONE

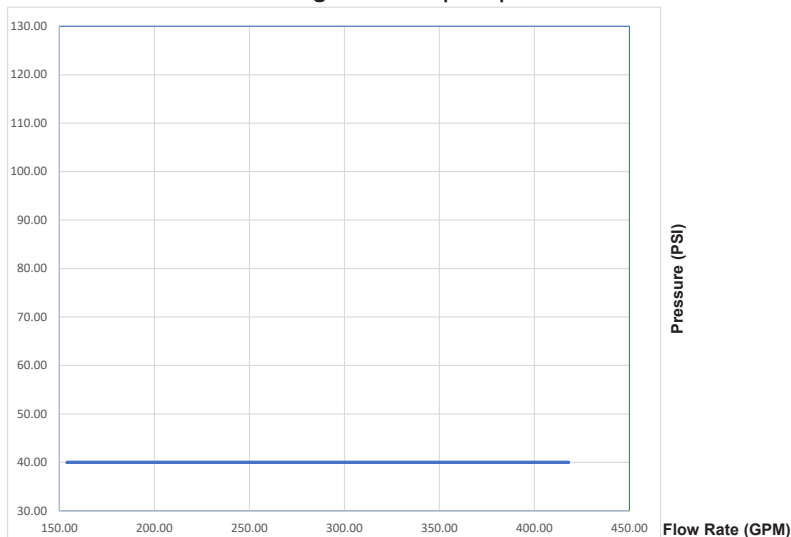



TECHNICAL DATA

MODEL VFC FOAM CHAMBERS

The Viking Corporation, 210 N Industrial Park Drive, Hastings MI 49058
 Telephone: 269-945-9501 Technical Services: 877-384-5464 Fax: 269-818-1680 Email: techsvcs@vikingcorp.com
 Visit the Viking website for the latest edition of this technical data page.

Table 7.4

FM Approvals: Ethanol ^{1,4}														
Foam Concentrate	Inlet Size	Working Pressure ¹				Flow Range				Orifice Range		Minimum Listed Foam Design Density		Graph Reference
		Minimum		Maximum		Minimum		Maximum		Inches	mm	gpm/ft ²	Lpm/m ²	
		PSI	bar	PSI	bar	GPM	LPM	GPM	LPM					
ARK 3%	2.5"	40	3	125	9	43	163	226	856	0.600 – 1.050	15 – 27	0.167	6.8	7.4.1
	3"	40	3	125	9	96	363	480	1817	0.906 – 1.531	23 – 39	0.167	6.8	7.4.2
	4"	40	3	40	3	154	583	415	1571	1.142 – 1.900	29 – 48	0.167	6.8	7.4.3

Footnotes:

1. This table shows approvals available at the time of publication.
2. Density indicated is minimum application density required per FM5130 Standard for Foam Equipment and Liquid Concentrates. This density cannot be reduced.
3. Working pressure on the upstream side of the inlet orifice of the foam chamber.
4. Refer to the graphs below for design range.

Graph 7.4.1

2.5" Model VFC With Viking ARK 3% | FM | ETHANOL

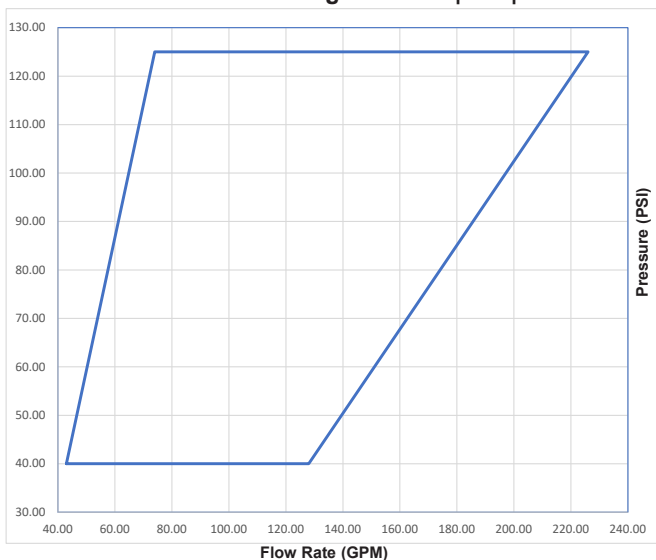

Graph 7.4.2

3" Model VFC With Viking ARK 3% | FM | ETHANOL

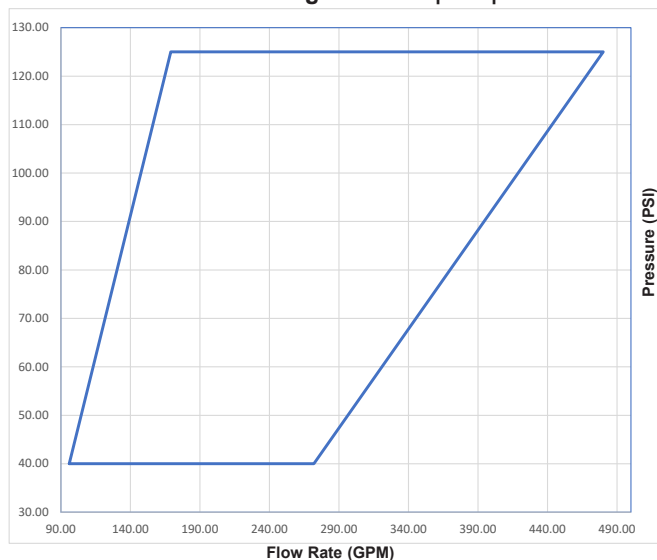

Graph 7.4.2

3" Model VFC With Viking ARK 3% | FM | ETHANOL

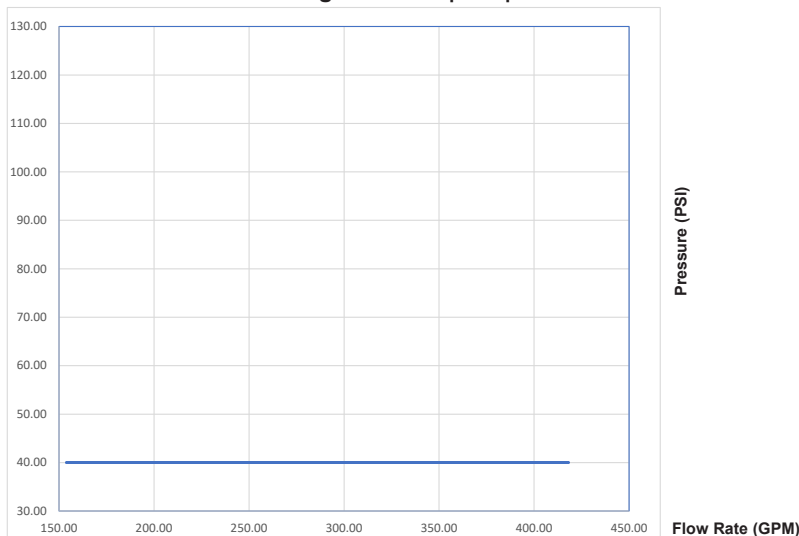

	<h1 style="margin: 0;">TECHNICAL DATA</h1>	<h2 style="margin: 0;">MODEL VFC FOAM CHAMBERS</h2>
---	--	---

The Viking Corporation, 210 N Industrial Park Drive, Hastings MI 49058
 Telephone: 269-945-9501 Technical Services: 877-384-5464 Fax: 269-818-1680 Email: techsvcs@vikingcorp.com
 Visit the Viking website for the latest edition of this technical data page.

Table 7.5

UL Listing: Hydrocarbon ^{1,4}														
Foam Concentrate	Inlet Size	Working Pressure ¹				Flow Range				Orifice Range		Minimum Listed Foam Design Density		Graph Reference
		Minimum		Maximum		Minimum		Maximum						
		PSI	bar	PSI	bar	GPM	LPM	GPM	LPM	Inches	mm	gpm/ft ²	Lpm/m ²	
USP 3%	3"	45	3.1	125	9	101	382	480	1817	0.906 – 1.531	23 – 39	0.1	4.1	7.5.1

Footnotes:

1. This table shows approvals available at the time of publication.
2. Density indicated is minimum application density required per UL162 Standard for Foam Extinguishing Systems. This density cannot be reduced.
3. Working pressure on the upstream side of the inlet orifice of the foam chamber.
4. Refer to the graphs below for design range.

Graph 7.5.1
3" Model VFC With Viking USP 3% | UL | HYDROCARBON

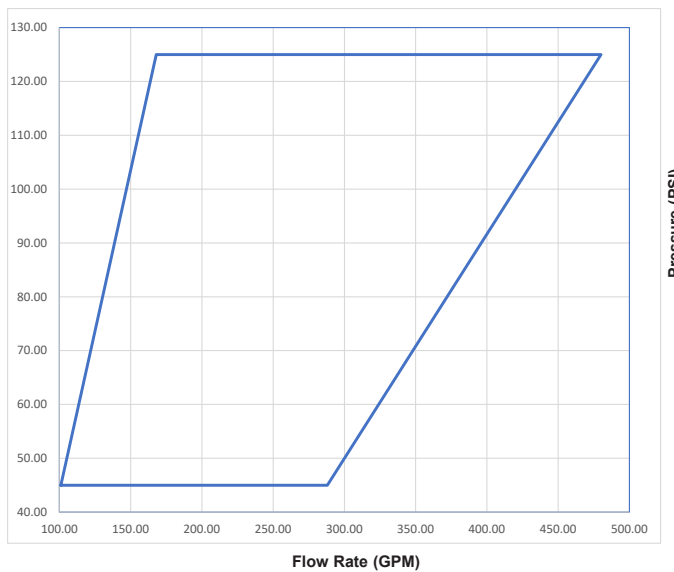



TECHNICAL DATA

MODEL VFC FOAM CHAMBERS

The Viking Corporation, 210 N Industrial Park Drive, Hastings MI 49058

Telephone: 269-945-9501 Technical Services: 877-384-5464 Fax: 269-818-1680 Email: techsvcs@vikingcorp.com

Visit the Viking website for the latest edition of this technical data page.

8. INSTALLATION

Refer to appropriate Installation Standards (i.e. NFPA11, EN13565-2).

Do not alter the piping without consulting a system design representative.

Foam chambers are compatible with many types of Foam Concentrate but are only UL Listed when used with the specific Foam Concentrates detailed on www.approvalguide.com or <https://iq.ulprospector.com>

Foam Chambers are generally installed on the side wall of vertical storage tanks above the maximum product storage level. Piping coupled to the unit can be linked to a fixed foam proportioning system, or terminated a safe distance from the tank, where foam solution can be delivered via mobile fire apparatus or portable foam proportioning equipment.

Care should be taken during the filling of the storage tanks with flammable liquids to ensure that the internal pressure is relieved to avoid rupturing the Foam Chamber vapor seals due to excessive back pressure.

It is recommended to install the deflector before the foam chamber is positioned onto the tank wall studs or mounting flange bolts. If the storage tank is new and access is possible to the inside of the tank then a solid deflector can be used. Use the split deflector when installation has to be made from the outside of the tank. The split deflector can be disassembled into 2 pieces. The section with flange holes can be passed through the flange opening in the tank wall and installed onto the existing studs or mounting flange bolts. After the first part is securely in place, the second half of the deflector can be passed through the flange opening and secured to the first part using the bolts provided.

Always verify that the vapor seal is in place and undamaged due to transportation and installation.

9. OPERATION

Foam solution can be delivered to the foam chamber in a variety of ways as previously noted.

The Foam Chamber produces foam by introducing air into the foam solution stream.

Air is drawn into the foam maker section through a series of annular holes located around the integral foam maker. To prevent obstruction, the air inlet holes are protected by a stainless steel screen (mesh) selected with a perforation size designed to exclude most known nesting birds and insects. The open area of the screen is designed to be not less than the total area of the foam maker air inlet holes.

The Aluminium foil burst disc is perforated due to the system supply pressure and the expanded foam enters the main mixing chamber where further agitation takes place before being discharged through the oversized outlet and deflecting onto and down the tank wall before rapidly spreading across the liquid surface.

10. GUARANTEE

For details of warranty, refer to Viking's current list price schedule or contact Viking directly.

11. INSPECTIONS, TESTS, AND MAINTENANCE

NOTICE

The owner is responsible for maintaining the fire protection system and devices in proper operating condition.

⚠ WARNING

Any system maintenance that involves placing a control valve or detection system out of service may eliminate the fire protection capabilities of that system. Prior to proceeding, notify all Authorities Having Jurisdiction. Consideration should be given to employment of a fire patrol in the affected areas.

Refer to respective requirements, according to the relevant standards for Inspection, Testing and Maintenance. If applicable, refer to FM Global Property Loss Prevention Datasheet 4-12 for specific test and commissioning criteria.

11.1 Vapor Seal Inspection

Inspection of the vapor seal is recommended as part of the fire protection system maintenance schedule. As Foam Chambers are installed at height, care should be taken to ensure a safe working platform or other suitable access is in place before commencing this work.

The vapor seal is accessed by removing all but one of the inspection cover bolts. The cover can then be rotated to one side taking care not to damage or dislodge the cover seal. A visual inspection can then be performed to check if the foil vapor seal is still intact.



TECHNICAL DATA

MODEL VFC FOAM CHAMBERS

The Viking Corporation, 210 N Industrial Park Drive, Hastings MI 49058

Telephone: 269-945-9501 Technical Services: 877-384-5464 Fax: 269-818-1680 Email: techsvcs@vikingcorp.com

Visit the Viking website for the latest edition of this technical data page.

11.2 Vapor Seal Replacement

If the vapor seal needs replacing the retaining bolts on the vapor seal retaining assembly should be carefully removed and kept secure. The assembly cover can then be removed and the vapor seal replaced. Care should be taken to ensure the correct vapor seal is selected in accordance with the instruction in Table 13.1.2.

The vapor seal assembly cover can then be remounted and the retaining bolts secured to a torque of 90 in-lbs (12.2 Nm). The inspection cover can be moved back into position taking care that the inspection cover seal is undamaged during the process. The inspection cover bolts can then be inserted and tightened to a torque of 40 ft-lbs (54 Nm).

12. DISPOSAL



At end of use the product described here should be disposed of via the national recycling system. Upon request, the manufacturer can take back and properly dispose of the electrical equipment and electronic devices.

13. ACCESSORIES AND SPARE PARTS

Due to the wide operating range of the Foam Chambers it is necessary to have different vapor seals depending on the inlet orifice size selected. When ordering spare or replacement vapor seals, care should be taken to check the Foam Chamber orifice size and match with the correct vapor seal as shown in table 13.1.1. The 6" Foam Chamber has 1 vapor seal option for the full orifice range.

- When the official purchase order is made for the orifice plate kit, the Foam Chamber size, the orifice inlet pressure and desired flow rate must be provided (required).

NOTE: The inlet orifice size will be manufactured to match the pressure and flow information provided in step 2 and assembled with the correct vapor seal. Any modifications made after the release of the foam chamber are the responsibility and at the risk of the authorized purchaser. Changes could include but are not limited to an entire system redesign, revamping of system components, restocking fees, etc.

- The final (ordering) part number will contain the required orifice size. Example: An orifice plate for a 2 1/2" Foam Chamber with a 0.750" orifice will be given the part number F21499/0750.

Table 13.1.1 - Accessories

Vapor Seals				
Part Number	Orifice Size Range	Foam Chamber Size	Vapor Seal Thickness	
			Inches	Millimeters
F22230	0.600" - 0.875"	2-1/2"	0.0005	0.0127
F22231	0.875" - 1.050"		0.0007	0.0178
F25561	0.906" - 1.150"	3"	0.0005	0.0127
F22232	1.150" - 1.371"		0.0007	0.0178
F25562	1.371" - 1.531"	4"	0.001	0.0254
F22234	1.142" - 1.540"		0.001	0.0254
F25564	1.540" - 1.900"		0.0015	0.0381
F22236	1.900" - 2.481"	6"	0.002	0.0508

Table 13.1.2 - Orifice Plate Kits (Includes Orifice Plate and Vapor Seal)

Part Number	Orifice Size Range	Foam Chamber Size
F21499	0.600" - 1.050"	2-1/2"
F21500	0.906" - 1.531"	3"
F21501	1.142" - 1.900"	4"
F21502	1.900" - 2.481"	6"

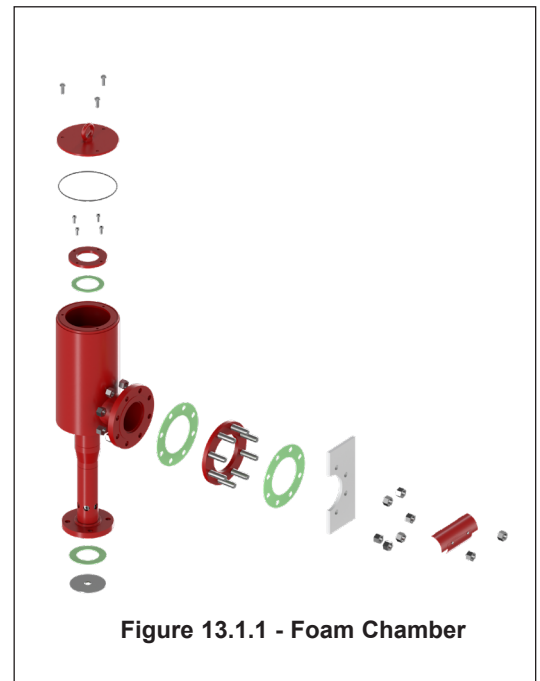

Figure 13.1.1 - Foam Chamber

14. DECLARATION OF CONFORMITY

If required, contact the appropriate sales office in **Section 5 Availability** for further assistance.