



**TECHNICAL DATA**

**COIN® QUICK  
RESPONSE UPRIGHT  
SPRINKLER VK950  
(SPECIFIC APPLICATION)**

The Viking Corporation, 210 N Industrial Park Drive, Hastings MI 49058  
 Telephone: 269-945-9501 Technical Services: 877-384-5464 Fax: 269-818-1680 Email: techsvcs@vikingcorp.com  
 Visit the Viking website for the latest edition of this technical data page: www.vikinggroupinc.com

**1. DESCRIPTION**

Viking QR COIN® Sprinklers are quick response specific application sprinklers for combustible interstitial (concealed) spaces (i.e., between floors, as well as low pitch attics that meet the criteria shown in the figures in this data page). These upright sprinklers are designed for use in specific light hazard combustible, as well as non-combustible, concealed spaces requiring sprinkler protection. The orifice design of the Viking QR COIN® Sprinkler, with a nominal K-factor of 5.6 (80 metric\*), allows efficient use of available water supplies for hydraulically designed fire protection systems. The glass bulb operating element and special deflector combine speed of operation and area of coverage to meet the crucial fire protection requirement for shallow space combustible concealed spaces. The Electroless Nickel PTFE (ENT) coating has been investigated for installation in corrosive environments and is listed/approved as indicated in the Approval Charts.

**FEATURES**

- In some cases COIN® Sprinklers can allow the use of CPVC piping within the concealed spaces of applications requiring sprinkler protection in open truss construction of both wood and steel trusses (see Figure 3) and solid wood or composite wood joist with upper deck filled with non-combustible insulation (see Figure 5).
- COIN® Sprinklers can also be installed with steel pipe in protected areas constructed of solid wood joists (see Figure 7), and solid wood or composite wood joist with upper deck filled with non-combustible insulation (see Figure 8), and in unobstructed open truss construction of both wood and steel trusses (see Figures 9 and 10) as well as obstructed wood truss construction (see Figure 11).
- When using steel pipe, COIN® Sprinklers can be applied as a dry system using air or gas as a supervisory medium (see Figures 7–11).
- In certain scenarios, draft curtains are **NOT** required when sprinkler spacing meets either of the following criteria (also refer to Design Criteria):
  - 14' X 14' (4,3 m X 4,3 m) for solid wood joists or trusses on edge
  - 16' X 16' (4,9 m X 4,9 m) for truss construction on face (not on edge)
 For examples of trusses on face or edge see Figures 13A and 13B.



COIN® Sprinkler	
VK950	5.6K (80 metric)

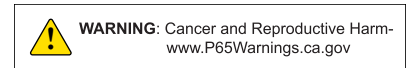

**2. LISTINGS AND APPROVALS**

 **cULus Listed:** Category VNIV

Refer to the Approval Chart and Design Criteria in this technical data sheet for cULus Listing requirements that must be followed. The COIN® Sprinkler has been tested to address the proper application density for shallow concealed combustible space fire protection when installed in accordance with this technical data page. The COIN® Sprinkler must be installed in the upright position as specified in the appropriate application described in Figures 3–12. The clearance from the sprinkler deflector to the roof is critical to operation of the sprinkler (refer to Figures 3–12). The clearances from pipe to lower ceiling for CPVC pipe is critical for protection of CPVC pipe.

For open truss and joist spaces, the maximum detection area is important for proper installation. In certain installations, draft curtains or heat collection baffles or solid walls are **required** using wood or other product that will not allow heat to escape. In these installations, the maximum detection space shall be **limited** to 1000 ft<sup>2</sup> (93 m<sup>2</sup>) or 2000 ft<sup>2</sup> (185 m<sup>2</sup>) for solid wood joists. The draft curtain is required to protrude down from the top deck surface as specified herein. Additionally, draft curtains are **not** required and the maximum detection space shall be **unlimited** for open truss construction with the top chord member on their face (not on edge) when sprinkler spacing is up to 16' X 16' (4,9 m X 4,9 m) and for solid wood joists or trusses on edge when sprinkler spacing is up to 14' X 14' (4,3 m X 4,3 m). In these cases, draft curtains are **not required**.



## TECHNICAL DATA

### COIN® QUICK RESPONSE UPRIGHT SPRINKLER VK950 (SPECIFIC APPLICATION)

The Viking Corporation, 210 N Industrial Park Drive, Hastings MI 49058

Telephone: 269-945-9501 Technical Services: 877-384-5464 Fax: 269-818-1680 Email: techsvcs@vikingcorp.com

Visit the Viking website for the latest edition of this technical data page: [www.vikinggroupinc.com](http://www.vikinggroupinc.com)

### 3. TECHNICAL DATA

#### Specifications:

Minimum Operating Pressure: Refer to Design Criteria in this technical data sheet.

Rated to 175 psi (12 bar) water working pressure

Factory tested hydrostatically to 500 psi (34.5 bar)

Thread size: 1/2" (15 mm) NPT

Nominal K-Factor: 5.6 U.S. (80 metric\*)

\* Metric K-factor measurement shown is when pressure is measured in Bar. When pressure is measured in kPa, divide the metric K-factor shown by 10.0.

Glass-bulb fluid temperature rated to -65 °F (-55 °C)

Overall Length: 2-1/4" (57 mm)

#### Material Standards:

Frame Casting: Brass UNS-C84400 or QM Brass

Deflector: Phosphor Bronze UNS-C51000

Bulb: Glass, nominal 3 mm diameter

Belleville Spring Sealing Assembly: Nickel Alloy, coated on both sides with PTFE Tape

Screw: Brass UNS-C36000

Pip Cap and Insert Assembly: Copper UNS-C11000 and Stainless Steel UNS-S30400

**Ordering Information: (Refer to Table 1.)**

### 4. INSTALLATION

Refer to appropriate NFPA Installation Standards.

### 5. OPERATION

During a fire condition, the heat sensitive liquid in the glass bulb expands, causing the glass to shatter, releasing the pip cap and sealing spring assembly. Water flowing through the sprinkler orifice strikes the deflector, forming a uniform spray pattern to extinguish or control the fire, and protect the piping in the interstitial space.

### 6. INSPECTIONS, TESTS AND MAINTENANCE

Refer to NFPA 25 for Inspection, Testing and Maintenance requirements.

### 7. AVAILABILITY

The Viking QR COIN® Sprinkler is available through a network of domestic and international distributors. See The Viking Corporation web site for the closest distributor or contact The Viking Corporation.

### 8. GUARANTEE

For details of warranty, refer to Viking's current list price schedule or contact Viking directly.

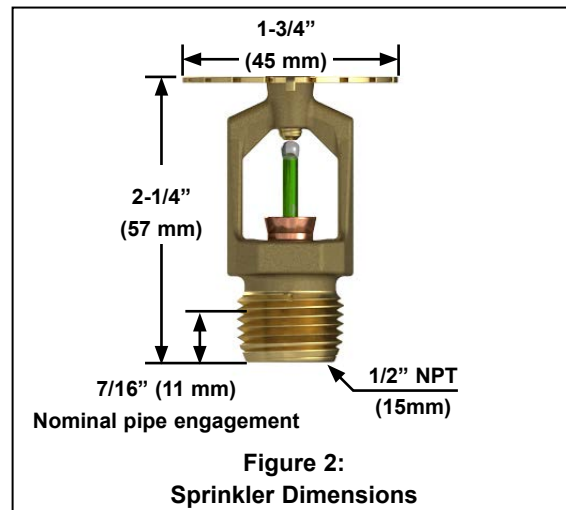
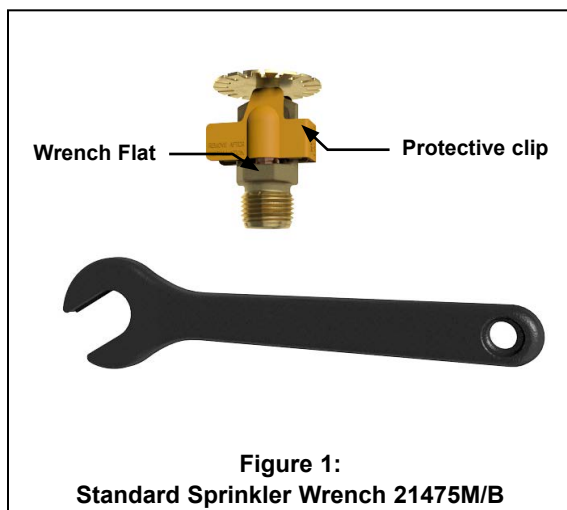



## TECHNICAL DATA

### COIN® QUICK RESPONSE UPRIGHT SPRINKLER VK950 (SPECIFIC APPLICATION)

The Viking Corporation, 210 N Industrial Park Drive, Hastings MI 49058  
 Telephone: 269-945-9501 Technical Services: 877-384-5464 Fax: 269-818-1680 Email: techsvcs@vikingcorp.com  
 Visit the Viking website for the latest edition of this technical data page: www.vikinggroupinc.com

#### TABLE 1: ORDERING INFORMATION

Instructions: Using the sprinkler base part number,  
 (1) add the suffix for the desired Finish  
 (2) add the suffix for the desired Temperature Rating.

Sprinkler Base Part No.	Size	1: Finishes		2: Temperature Ratings <sup>4</sup> Classification: Intermediate			
	NPT Inch	Description	Suffix	Nominal Rating	Bulb Color	Max. Ambient Ceiling Temperature <sup>1</sup>	Suffix
20757	1/2	Brass	A	200 °F (93 °C)	Green	150 °F (65 °C)	E
		ENT <sup>2,3</sup>	JN				

**Corrosion-Resistant Coating:**  
 ENT<sup>2,3</sup>

**Example:** 20757AE = VK950 with Brass Finish and 200 °F (93 °C) Nominal temperature rating. This sprinkler is to be installed into an area with a maximum ambient temperature of 150 °F (65 °C) meaning if the area will experience temperatures above the maximum ambient rating, you shall use a higher temperature-rated sprinkler.

#### Accessories

##### Sprinkler Wrenches (see Figure 1):

A. Standard Wrench: Part No. 21475MB.

##### Sprinkler Cabinet:

A. Up to 6 sprinklers: Part number 01724A.

B. 6-12 Sprinklers: Part number 01725A.

#### Footnotes

- Based on NFPA 13, NFPA 13R, and NFPA 13D. Other limits may apply, depending on fire loading, sprinkler location, and other requirements of the Authority Having Jurisdiction. Refer to specific installation standards.
- cULus Listed as corrosion resistant.
- The corrosion resistant coatings have passed the standard corrosion test required by the approving agencies indicated in the Approval Chart. These tests cannot and do not represent all possible corrosive environments. Prior to installation, verify through the end-user that the coatings are compatible with or suitable for the proposed environment. For automatic sprinklers, the ENT coating is applied to all exposed exterior surfaces, including the waterway. For ENT coated sprinklers, the Belleville spring is exposed.
- The sprinkler temperature rating is stamped on the deflector.

## Approval Chart

COIN® Specific Application QR Upright Sprinkler VK950  
 For Light Hazard Occupancies Only

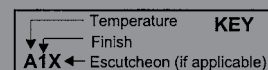

Part Number <sup>1</sup>	SIN	Maximum Pressure	Thread Size		Nominal K-Factor		Overall Length		Listings and Approvals <sup>3</sup> (Refer also to Design Criteria.)	
			NPT	BSPT	U.S.	metric <sup>2</sup>	Inches	mm	cULus <sup>4</sup>	
20757	VK950	175 psi	1/2"	15 mm	5.6	80	2-1/4	57	A1	
<b>Approved Temperature Rating</b> A - 200 °F (93 °C)							<b>Approved Finish</b> 1 - Brass, ENT <sup>6</sup>			

#### Footnotes

- Also refer to Viking's current price schedule.
- Metric K-factor measurement shown is when pressure is measured in Bar. When pressure is measured in kPa, divide the metric K-factor shown by 10.0.
- This table shows the listings and approvals available at the time of printing. Other approvals may be in process.
- Listed by Underwriters Laboratories Inc. for use in the U.S. and Canada.
- Meets New York City requirements, effective July 1, 2008.
- cULus Listed as corrosion resistant.



## TECHNICAL DATA

### COIN® QUICK RESPONSE UPRIGHT SPRINKLER VK950 (SPECIFIC APPLICATION)

The Viking Corporation, 210 N Industrial Park Drive, Hastings MI 49058

Telephone: 269-945-9501 Technical Services: 877-384-5464 Fax: 269-818-1680 Email: techsvcs@vikingcorp.com

Visit the Viking website for the latest edition of this technical data page: [www.vikinggroupinc.com](http://www.vikinggroupinc.com)

#### DESIGN CRITERIA - CPVC PIPE (See Figures 3-6)

(Also refer to the Approval Chart on page 3.)

The Viking COIN® Sprinkler MUST be installed in the upright position.

#### APPLICATION

For installation in horizontal interstitial concealed spaces constructed of engineered open wood trusses, open bar joist, and non-combustible insulation completely filling the upper joist for solid or composite wood joist construction having roof pitch of up to 2/12.

**NOTE:** In order to be considered "non-combustible insulation filled solid wood or composite wood joist construction", the insulation (including insulation provided with a combustible vapor barrier), must completely fill the pockets between the joists to the bottom of the joists, and the insulation must be secured in place with metal wire netting. The metal wire netting is intended to hold the insulation in place should the insulation become wetted by the operation of the COIN® Sprinklers in the event of a fire.

#### A. Concealed Space Limitations

The total concealed space is not limited; however, the following must be observed:

- Draft curtains (heat collection baffle) or full height walls must be provided to limit the maximum area in order to confine heat of localized detection area to 1000 ft<sup>2</sup> (93 m<sup>2</sup>) or, for solid wood joists and open truss construction with the top chord members on face (not on edge) to 2000 ft<sup>2</sup> (185 m<sup>2</sup>).
- Insulated top chord spaces (on edge) confine heat localized detection area to 2000 ft<sup>2</sup>, non-insulated top chord spaces (on edge) confine heat localized area to 1000 ft<sup>2</sup> (93 m<sup>2</sup>).
- The draft curtain must be at least 1/3 the depth of the concealed space or 8" (200 mm), whichever is greater, for open truss construction, open bar joist, and non-combustible insulation filled solid or composite wood joist construction.
- The draft curtain must be constructed of material that will not allow heat to escape through or above it; this may be 1/4" (6 mm) thick plywood.
- Draft curtains are NOT required when sprinkler spacing is up to 14' X 14' (4,3 m X 4,3 m) for solid wood joists or trusses on edge; see Figure 13B.
- Draft curtains are NOT required when sprinkler spacing is up to 16' X 16' (4,9 m X 4,9 m) for truss construction on face (not on edge); see Figure 13A.
- Draft curtains are NOT required when using wood truss construction with chords on face and non-combustible insulation is provided to the bottom of the trusses (Figure 12).

#### B. Concealed Space Height

Open Wood Truss and Open Steel Joist Construction (Figure 3):

- Maximum height of the space: 60" (1.5 m).
- Minimum height: 6" (150 mm)
- Maximum roof pitch: 2/12 (9°)

Where applied to pitch roof and flat ceiling, maintain specified clearances from sprinkler deflector to truss and maximum height of pipe run to ceiling or non-combustible ceiling insulation in all locations. **NOTE:** The sprinkler deflector shall be installed parallel with the roof plane.

Solid wood or composite wood joist with non-combustible filled insulation only (Figure 5):

- Maximum depth of concealed space is 60" (1500 mm) from bottom of upper deck joist to top of ceiling joist.
- Minimum depth is 6" (152 mm) from bottom of upper deck joist to top of ceiling joist or non-combustible ceiling insulation.

#### C. System Type

- Light Hazard, Wet Pipe System

#### D. Minimum Density

- 0.10 gpm/ft<sup>2</sup> (4.1 mm/min).

#### E. Spacing of COIN® Sprinklers

- Minimum Spacing: 6'-0" (1.8 m)
- Maximum Spacing: 16'-0" (4.9 m)

**NOTE:** Minimum spacing does not include additional sprinklers required for obstructions for use of CPVC pipe that includes offsets.

#### F. Maximum Area of Coverage

- 256 ft<sup>2</sup> (24 m<sup>2</sup>)

#### G. Minimum Operating Pressure

- 7.0 PSI (0.5 bar)

#### H. COIN® Sprinkler Deflector Position

The COIN® Sprinkler shall be installed in the upright position. The frame arms must be installed parallel with the pipe.

- 1-1/2" to 4" (40 - 100 mm) below upper deck for Open Wood Truss and Open Steel Open Joist Construction Using CPVC Pipe (see Figure 3).
- 1-1/2" to 4" (40 - 100 mm) below non-combustible insulation-filled upper deck for Open Wood Truss and Open Steel Open Joist Construction with Using CPVC Pipe (see Figure 4).
- 1-1/2" to 4" (40 - 100 mm) below non-combustible insulation-filled solid wood joists or composite wood joists (see Figure 5).

(continues on page 5.)



## TECHNICAL DATA

### COIN® QUICK RESPONSE UPRIGHT SPRINKLER VK950 (SPECIFIC APPLICATION)

The Viking Corporation, 210 N Industrial Park Drive, Hastings MI 49058  
 Telephone: 269-945-9501 Technical Services: 877-384-5464 Fax: 269-818-1680 Email: techsvcs@vikingcorp.com  
 Visit the Viking website for the latest edition of this technical data page: www.vikinggroupinc.com

#### DESIGN CRITERIA - CPVC PIPE (See Figures 3-6)

(Also refer to the Approval Chart)

(continued from page 4.)

#### I. Remote Area

For wet pipe systems,

- The remote area for open wood truss construction or open bar joist construction with the top chord members on face (not on edge) is 1000 ft<sup>2</sup> (93 m<sup>2</sup>) or 6 sprinklers, whichever is greater. See Table 2.
  - Draft curtains are NOT required when sprinkler spacing is up to 16' X 16' (4,9 m X 4,9 m). The remote area for this application is the same as above.
- The remote area for solid wood joists is 1000 ft<sup>2</sup> (93 m<sup>2</sup>) or 6 sprinklers, whichever is greater. See Table 2.
  - Draft curtains are NOT required when sprinkler spacing is up to 14' X 14' (4,3 m X 4,3 m). The remote area for this application is the same as above.
- The remote area for open wood truss construction with the top chord members on edge is 1000 ft<sup>2</sup> (93 m<sup>2</sup>) or 6 sprinklers, whichever is greater. See Table 2.
  - Draft curtains are NOT required when sprinkler spacing is up to 14' X 14' (4,3 m X 4,3 m) The remote area for this application is the same as above.
- The remote area for composite wood joists is 1000 ft<sup>2</sup> (93 m<sup>2</sup>).

**NOTE:** This area does not include additional sprinklers for protection of CPVC pipe over obstructions.

#### J. UL Listed CPVC Pipe for use with COIN™ Sprinklers

The Viking COIN® Sprinkler is UL Listed for use with CPVC pipe products listed for use in concealed spaces with sprinklers\*\*.

\*\*Currently listed products are manufactured under the BlazeMaster®, FireLock®, and FlameGuard® trade names.

In order to use CPVC products, the bottom of the horizontal run must be no greater than 6" (150 mm) or 1/3 of the total space, whichever is smaller, above the ceiling or non-combustible insulation or 1/3 the depth of the space measured from the top surface of the ceiling to the bottom of the deck above. The CPVC pipe can supply the COIN® Sprinklers and the ceiling sprinklers below. Use all guidelines and installation instructions as specified by the CPVC pipe manufacturers unless specified differently in this data sheet. When using 1" (DN25) pipe or larger, a hanger must be located at the truss nearest the sprig for restraint. If using ¾" (DN20), all sprigs over 12" (300 mm) must include lateral bracing.

For use of listed CPVC pipe products in concealed spaces using the COIN® Sprinkler, a minimum lateral distance of 18" (450 mm) must be maintained between the CPVC pipe and the heat sources (e.g. HVAC heat pump units, fan motors, and heat lamps, etc.)

Where CPVC pipe must be installed above the maximum distance of 6" (150 mm) or 1/3 of the total space, whichever is smaller, above the ceiling or non-combustible insulation when piping around obstructions, additional COIN® Sprinklers must be installed as shown in Figures 3, 4, and 5 in order to protect the CPVC product.

**NOTE:** Where CPVC piping is installed as a vertical riser to the next floor above, refer to Figure 6 for acceptable options.

#### TABLE 2: PRESSURE VS. COVERAGE MATRIX

All values based on 0.1 gpm/ft<sup>2</sup> density per sprinkler or 7 psi (0.5 bar) whichever is higher.

Ft. (m)	PSI (bar)								
	16 (4.8)	7 (0.4)	7.2 (0.4)	8.2 (0.5)	10.3 (0.7)	12.8 (0.8)	14.1 (0.9)	16.9 (1.1)	18.4 (1.2)
15 (4.5)	7 (0.4)	7 (0.4)	7.2 (0.4)	9.2 (0.6)	10.3 (0.7)	12.8 (0.8)	14.1 (0.9)	16.9 (1.1)	18.4 (1.2)
14 (4.2)	7 (0.4)	7 (0.4)	7 (0.4)	8.2 (0.5)	9.2 (0.6)	11.5 (0.7)	12.8 (0.8)	14.1 (0.9)	16.9 (1.1)
13 (3.9)	7 (0.4)	7 (0.4)	7 (0.4)	7 (0.4)	8.2 (0.5)	9.2 (0.6)	11.5 (0.7)	12.8 (0.8)	14.1 (0.9)
12 (3.6)	7 (0.4)	7 (0.4)	7 (0.4)	7 (0.4)	7 (0.4)	8.2 (0.5)	9.2 (0.6)	10.3 (0.7)	12.8 (0.8)
11 (3.3)	7 (0.4)	7 (0.4)	7 (0.4)	7 (0.4)	7 (0.4)	7 (0.4)	8.2 (0.5)	9.2 (0.6)	10.3 (0.7)
10 (3.0)	7 (0.4)	7 (0.4)	7 (0.4)	7 (0.4)	7 (0.4)	7 (0.4)	7 (0.4)	7.2 (0.4)	8.2 (0.5)
9 (2.7)	7 (0.4)	7 (0.4)	7 (0.4)	7 (0.4)	7 (0.4)	7 (0.4)	7 (0.4)	7 (0.4)	7.2 (0.4)
8 (2.4)	7 (0.4)	7 (0.4)	7 (0.4)	7 (0.4)	7 (0.4)	7 (0.4)	7 (0.4)	7 (0.4)	7 (0.4)
Ft. (m)	8 (2.4)	9 (2.7)	10 (3.0)	11 (3.3)	12 (3.6)	13 (3.9)	14 (4.2)	15 (4.5)	16 (4.8)

#### NOTES:

- This table applies to heat collection areas of 2000 ft<sup>2</sup> (185 m<sup>2</sup>) and greater (unlimited).
- Design areas between table spacing values need to be rounded up.
- This table does not apply to heat collection areas of 1000 ft<sup>2</sup> (93 m<sup>2</sup>).



**TECHNICAL DATA**

**COIN® QUICK  
RESPONSE UPRIGHT  
SPRINKLER VK950  
(SPECIFIC APPLICATION)**

The Viking Corporation, 210 N Industrial Park Drive, Hastings MI 49058  
 Telephone: 269-945-9501 Technical Services: 877-384-5464 Fax: 269-818-1680 Email: techsvcs@vikingcorp.com  
 Visit the Viking website for the latest edition of this technical data page: www.vikinggroupinc.com

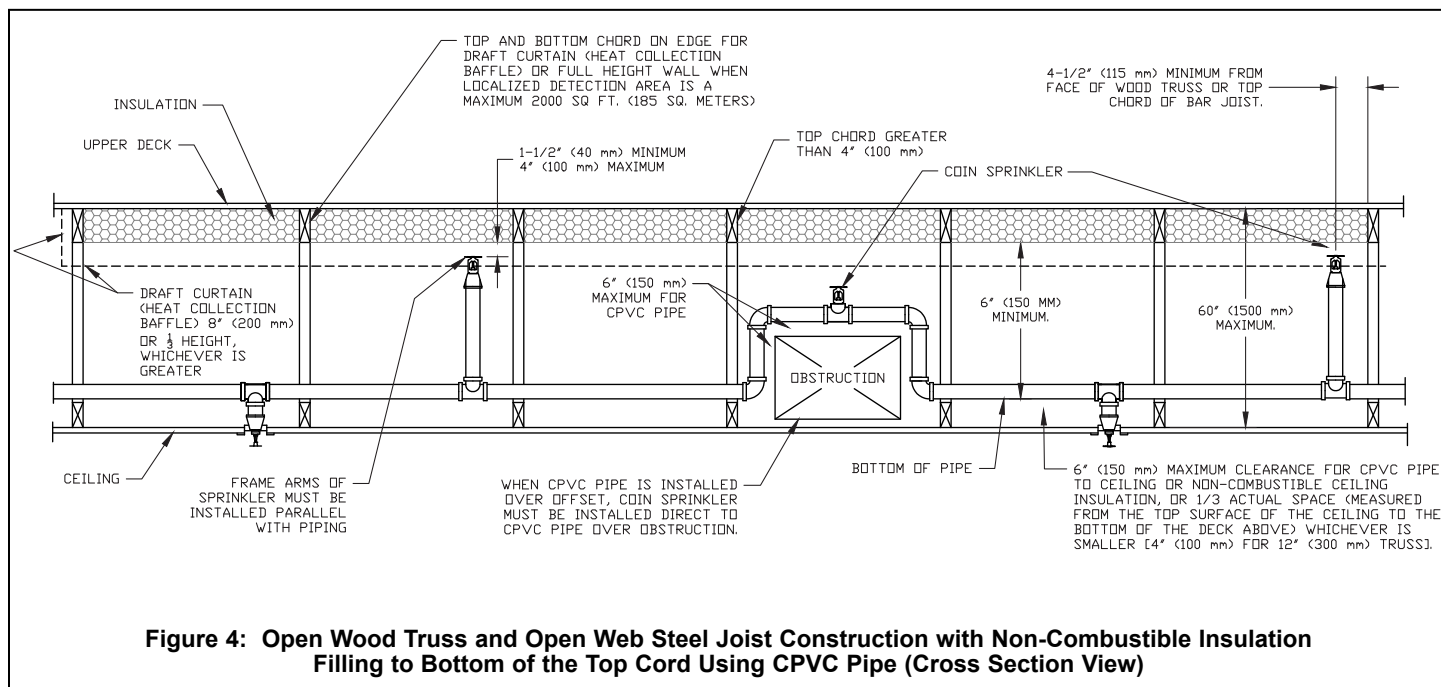
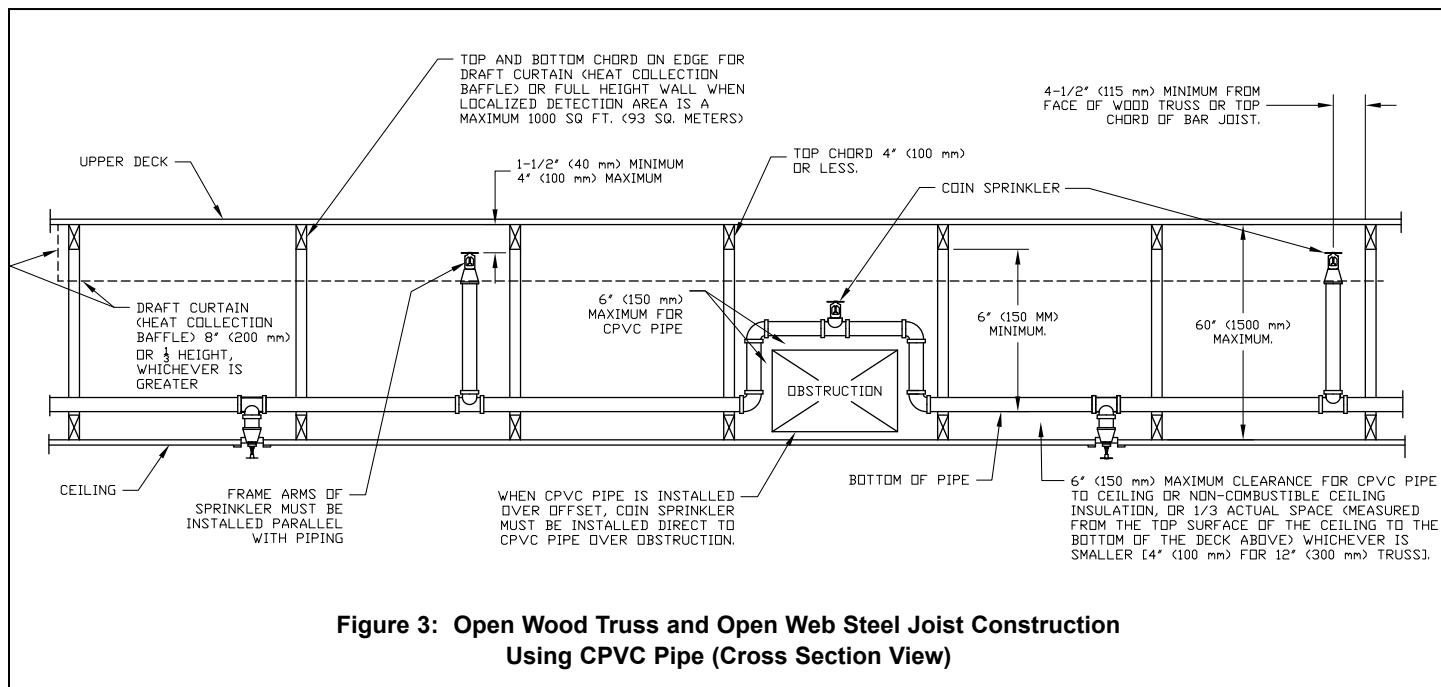



**TECHNICAL DATA**

**COIN® QUICK  
RESPONSE UPRIGHT  
SPRINKLER VK950  
(SPECIFIC APPLICATION)**

The Viking Corporation, 210 N Industrial Park Drive, Hastings MI 49058  
 Telephone: 269-945-9501 Technical Services: 877-384-5464 Fax: 269-818-1680 Email: techsvcs@vikingcorp.com  
 Visit the Viking website for the latest edition of this technical data page: www.vikinggroupinc.com

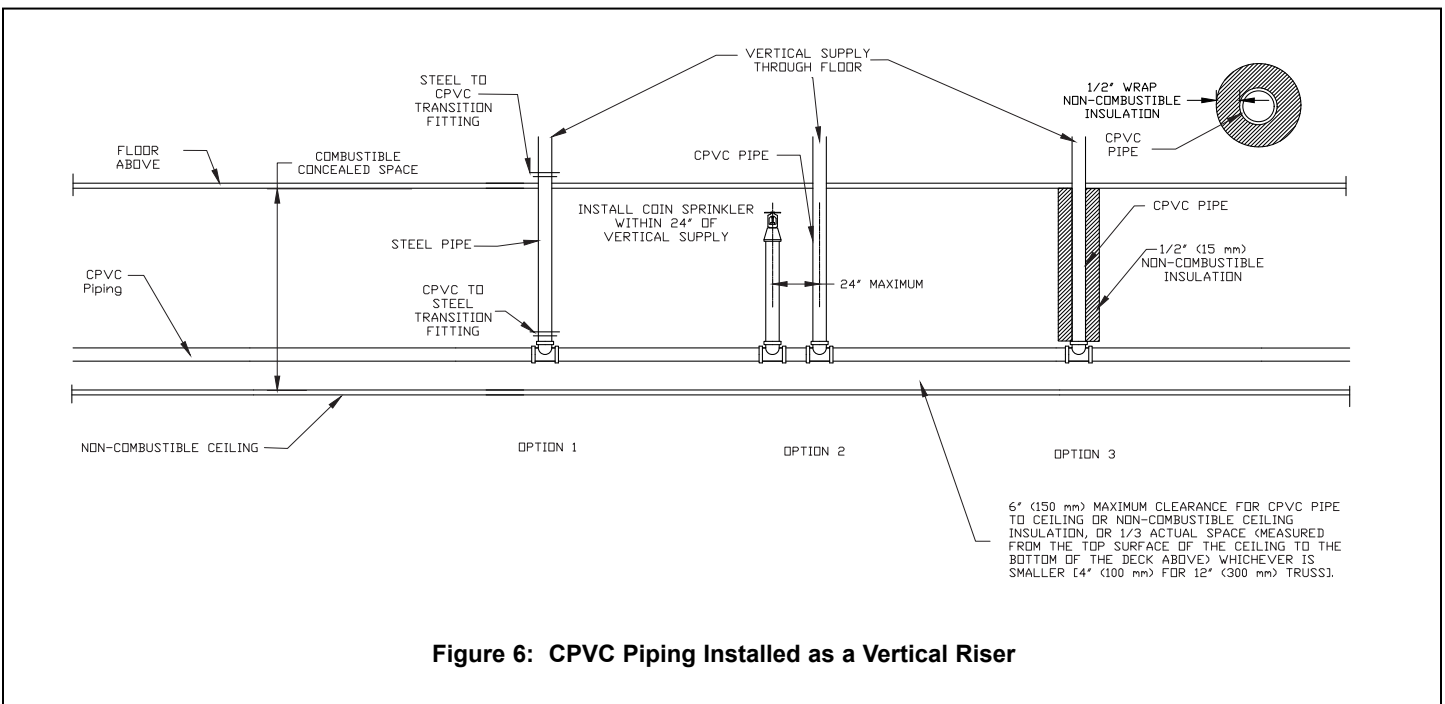
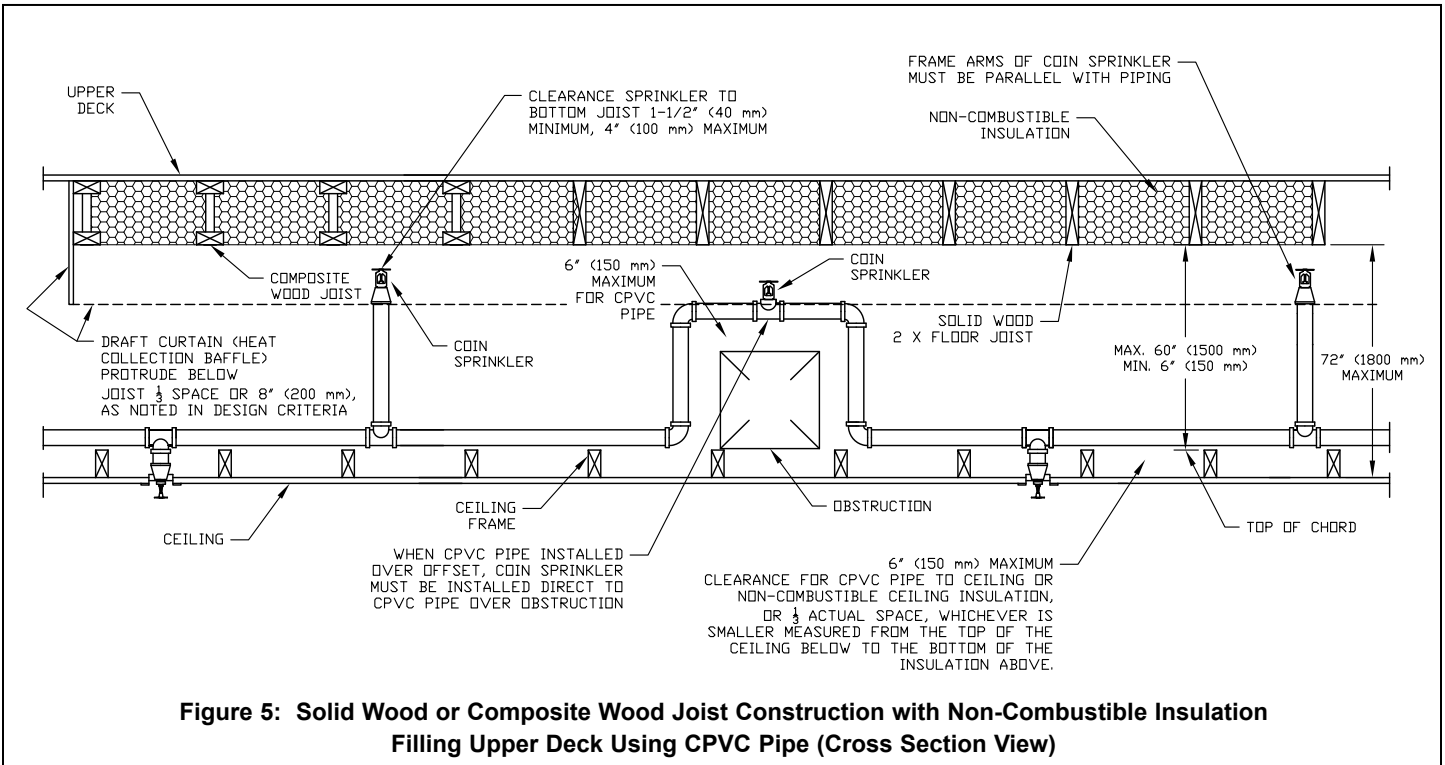



## TECHNICAL DATA

## COIN® QUICK RESPONSE UPRIGHT SPRINKLER VK950 (SPECIFIC APPLICATION)

The Viking Corporation, 210 N Industrial Park Drive, Hastings MI 49058  
 Telephone: 269-945-9501 Technical Services: 877-384-5464 Fax: 269-818-1680 Email: techsvcs@vikingcorp.com  
 Visit the Viking website for the latest edition of this technical data page: www.vikinggroupinc.com

### DESIGN CRITERIA - STEEL PIPE (See Figures 7 – 12)

(Also refer to the Approval Chart on page 3)

The Viking COIN® Sprinkler MUST be installed in the upright position.

#### APPLICATION

For installation in horizontal concealed spaces of solid wood joist construction with a roof pitch of up to 2/12 maximum. The upper joist is constructed of solid wood or composite wood with a maximum depth of 12" (300 mm) and 16" (400 mm) on center minimum spacing. Also, steel pipe may be applied in truss construction and solid filled non-combustible insulation in upper deck and wood or composite joist construction similar to that shown in Figures 3-5 with the exception of extra sprinklers are not required over obstructions. Also, there is no minimum clearance for supply pipe to upper joists. With the COIN® Sprinkler applied using steel pipe, the system may be wet, dry, or preaction type for wood truss or steel construction; solid wood or composite with non-combustible solid fill insulation (see Paragraph J on page 9).

**NOTE:** In order to be considered "non-combustible insulation filled solid wood or composite wood joist construction", the insulation (including insulation provided with a combustible vapor barrier), must completely fill the pockets between the joists to the bottom of the joists, and the insulation must be secured in place with metal wire netting. The metal wire netting is intended to hold the insulation in place should the insulation become wetted by the operation of the COIN® Sprinklers in the event of a fire.

#### A. Concealed Space Limitations

The total concealed space is not limited; however, the following must be observed:

- Blocking between joists and upper deck must be constructed of material that will not allow heat to escape through or above the blocking.
- The blocking must be constructed to the full depth of the upper joist, and must be constructed using a non-combustible material or a material that is the same as that of the joist construction. A maximum channel space for blocking is 32 ft (10 m) intervals.
- Solid wall construction or draft curtains (heat collection baffles) must protrude below the joist a minimum of 6" (150 mm) or 1/3 the space, whichever is greatest, and run laterally with the joist spaced at 31 ft (9.4 m) width maximum to limit the heat detection space to a maximum of 1,000 ft<sup>2</sup> (93 m<sup>2</sup>) or with the truss spaced at 62 ft (19 m) width maximum to limit the heat detection space for open wood truss construction to 2000 ft<sup>2</sup> (185 m<sup>2</sup>) with their top chord members on face (not on edge) and 2000 ft<sup>2</sup> (185 m<sup>2</sup>) for solid wood joists.
- Insulated top chord spaces (on edge) confine heat localized detection area to 2000 ft<sup>2</sup> (185 m<sup>2</sup>), non-insulated top chord spaces on edge confine heat localized area to 1,000 ft<sup>2</sup> (93 m<sup>2</sup>).
- The draft curtain may be constructed of 1/4" (6 mm) thick plywood to prevent heat from escaping beyond.
- When non-combustible solid filled insulation is used, the wood blocking and draft curtains are not required for solid wood or composite wood joist construction.
- Draft curtains are NOT required when sprinkler spacing is up to 14' X 14' (4.3 m X 4.3 m) for solid wood joists or trusses on edge for wet systems only; see Figure 13B.
- Draft curtains are NOT required when sprinkler spacing is up to 16' X 16' (4.9 m X 4.9 m) for truss construction on face (not on edge) for wet or dry systems; see Figure 13A.
- Draft curtains are NOT required when using wood truss construction with chords on face and non-combustible insulation is provided to the bottom of the trusses (Figure 12).

#### B. Concealed Space Height

Solid Wood or Composite Wood Joist Construction (See Figures 7 and 8):

- Maximum depth or height of concealed space: 60" (1500 mm) from bottom of upper deck joist to top of ceiling joist.
- Maximum space from bottom of upper deck to ceiling surface (bottom of joist): 84" (2100 mm). See Figure 7.
- Minimum depth or height of concealed space: 6" (150 mm) from bottom of upper deck joist to top of ceiling frame joist.

#### Open Wood Truss or Open Web Steel Joist (See Figure 10):

- Maximum height from inside ceiling to inside deck of concealed space: 60" (1500 mm).
- Minimum height from bottom of upper chords to top of lower chords: 6" (150 mm)
- The top and bottom chord members of these types of wood joists must be on face (not on edge).

#### Obstructed Wood Truss (See Figure 11):

- Maximum depth of concealed space: 84" (2100 mm) from bottom of upper deck to top of ceiling.
- Minimum depth of concealed space: 6" (150 mm) from bottom of upper chord to top of lower chord.

#### C. System Type

- Light hazard, wet pipe system or dry pipe system supervised with air or gas when using steel pipe only.

#### D. Minimum Density

- 0.10 gpm/ft<sup>2</sup>. (4.1 mm/min).

#### E. Spacing of COIN® Sprinklers

- Minimum Space Between Sprinklers: 6'-0" (1.8 m)
- Maximum Space Between Sprinklers: 16'-0" (4.9 m)

#### F. Maximum Area of Coverage

- 256ft<sup>2</sup> (24 m<sup>2</sup>)

#### G. Minimum Operating Pressure

- 7.0 PSI (0.5 bar)

#### H. COIN® Sprinkler Deflector Position

The COIN® Sprinkler shall be installed in the upright position. The frame arms must be installed parallel with the pipe.

- 1-1/2" to 2" (40 - 50 mm) below solid wood joist or top chord of obstructed wood truss construction. See Figures 7 and 11.
  - 1-1/2" to 4" (40 - 100 mm) below upper deck for unobstructed open wood truss construction or concealed spaces of non-combustible open steel joist construction. See Figures 8 and 9.
  - 1-1/2" to 4" (40 - 100 mm) below non-combustible insulation-filled solid wood joists or composite wood joists. See Figure 8.
- (continues on page 9.)





## TECHNICAL DATA

### COIN® QUICK RESPONSE UPRIGHT SPRINKLER VK950 (SPECIFIC APPLICATION)

The Viking Corporation, 210 N Industrial Park Drive, Hastings MI 49058  
 Telephone: 269-945-9501 Technical Services: 877-384-5464 Fax: 269-818-1680 Email: techsvcs@vikingcorp.com  
 Visit the Viking website for the latest edition of this technical data page: www.vikinggroupinc.com

#### DESIGN CRITERIA - STEEL PIPE (See Figures 7–12)

(Also refer to the Approval Chart on page 3)

(continued from page 8)

#### I. Remote Area

For wet pipe systems,

- The remote area for open wood truss construction or open bar joist construction with the top chord members on face (not on edge) is 1000 ft<sup>2</sup> (93 m<sup>2</sup>) or 6 sprinklers, whichever is greater. See Table 2.
  - Draft curtains are NOT required when sprinkler spacing is up to 16' X 16' (4,9 m X 4,9 m). The remote area for this application is the same as above.
- The remote area for solid wood joists is 1000 ft<sup>2</sup> (93 m<sup>2</sup>) or 6 sprinklers, whichever is greater. See Table 2.
  - Draft curtains are NOT required when sprinkler spacing is up to 14' X 14' (4,3 m X 4,3 m). The remote area for this application is the same as above.
- The remote area for open wood truss construction with the top chord members on edge is 1000 ft<sup>2</sup> (93 m<sup>2</sup>) or 6 sprinklers, whichever is greater. See Table 2.
  - Draft curtains are NOT required when sprinkler spacing is up to 14' X 14' (4,3 m X 4,3 m) The remote area for this application is the same as above.
- The remote area for composite wood joists is 1000 ft<sup>2</sup> (93 m<sup>2</sup>).

For dry pipe systems,

- The remote area for open wood truss construction or open bar joist construction with the top chord members on face (not on edge) is 1000 ft<sup>2</sup> (93 m<sup>2</sup>) or 6 sprinklers, whichever is greater. See Table 2.
  - Draft curtains are NOT required when sprinkler spacing is up to 16' X 16' (4,9 m X 4,9 m). The remote area for this application is the same as above.
- The remote area for solid wood joists is 2000 ft<sup>2</sup> (185 m<sup>2</sup>) or 15 sprinklers, whichever is greater. See Table 2.
- The remote area for open wood truss construction with the top chord members on edge is 1000 ft<sup>2</sup> (93 m<sup>2</sup>).
- The remote area for composite wood joists is 1000 ft<sup>2</sup> (93 m<sup>2</sup>).

#### J. Piping System

Steel pipe installed in accordance with NFPA 13 standards may be applied. The steel pipe may be hung from the upper joist or truss using proper supports. The sprinkler deflector must be positioned as indicated in paragraph H above. Extra sprinklers are not required for protection of pipe when offsetting for obstructions. Ceiling sprinklers below the concealed space may be fed from the same piping as the COIN® Sprinklers.

**IMPORTANT: Always refer to Bulletin Form No. F\_091699 - Care and Handling of Sprinklers. Also refer to Bulletin Form No. F\_080614 for general care, installation, and maintenance information. Viking sprinklers are to be installed in accordance with the latest edition of Viking technical data, the appropriate standards of NFPA, FM Global, LPCB, APSAD, VdS or other similar organizations, and also with the provisions of governmental codes, ordinances, and standards, whenever applicable.**

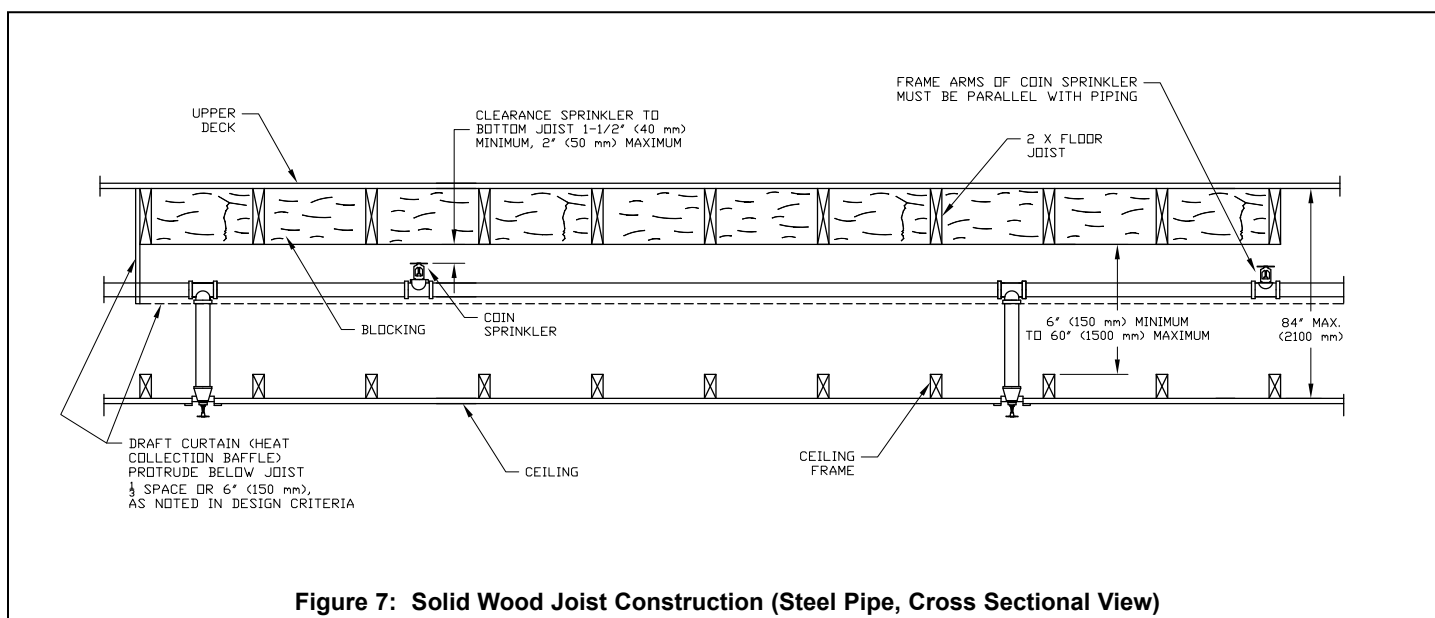

Figure 7: Solid Wood Joist Construction (Steel Pipe, Cross Sectional View)



**TECHNICAL DATA**

**COIN® QUICK  
RESPONSE UPRIGHT  
SPRINKLER VK950  
(SPECIFIC APPLICATION)**

The Viking Corporation, 210 N Industrial Park Drive, Hastings MI 49058  
 Telephone: 269-945-9501 Technical Services: 877-384-5464 Fax: 269-818-1680 Email: techsvcs@vikingcorp.com  
 Visit the Viking website for the latest edition of this technical data page: www.vikinggroupinc.com

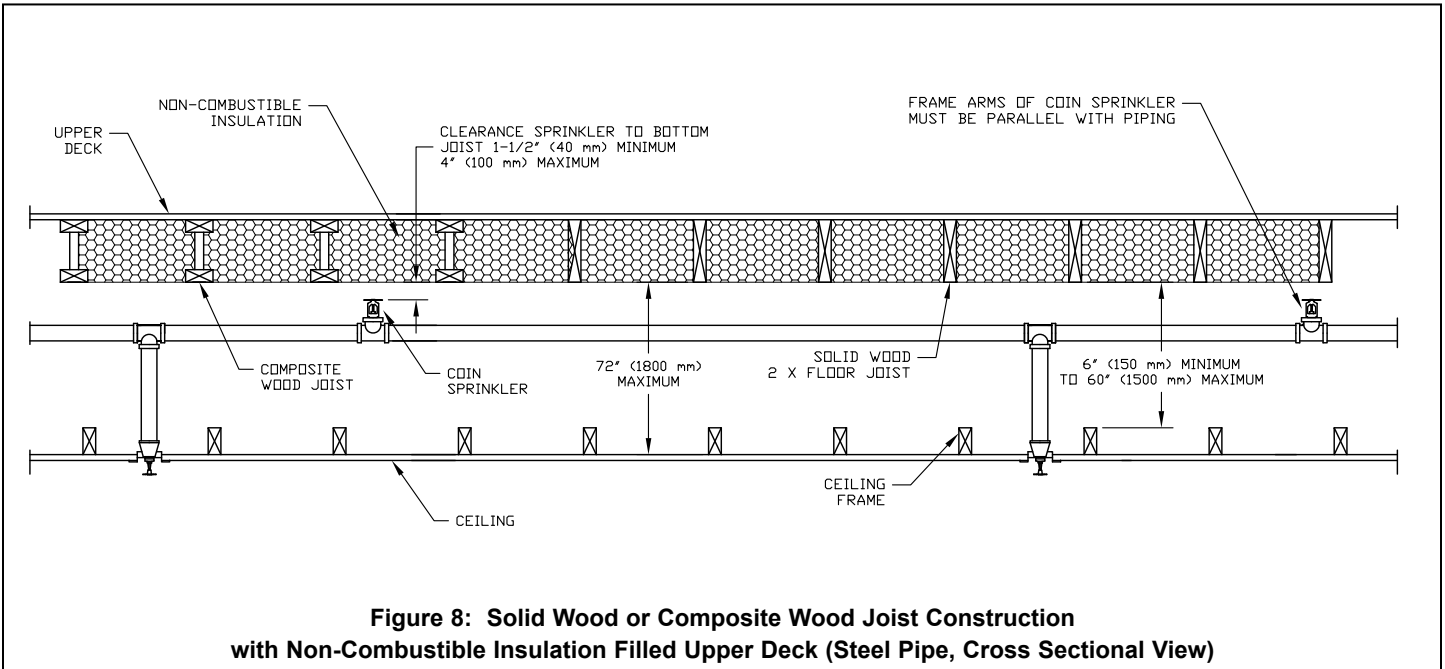

**Figure 8: Solid Wood or Composite Wood Joist Construction with Non-Combustible Insulation Filled Upper Deck (Steel Pipe, Cross Sectional View)**

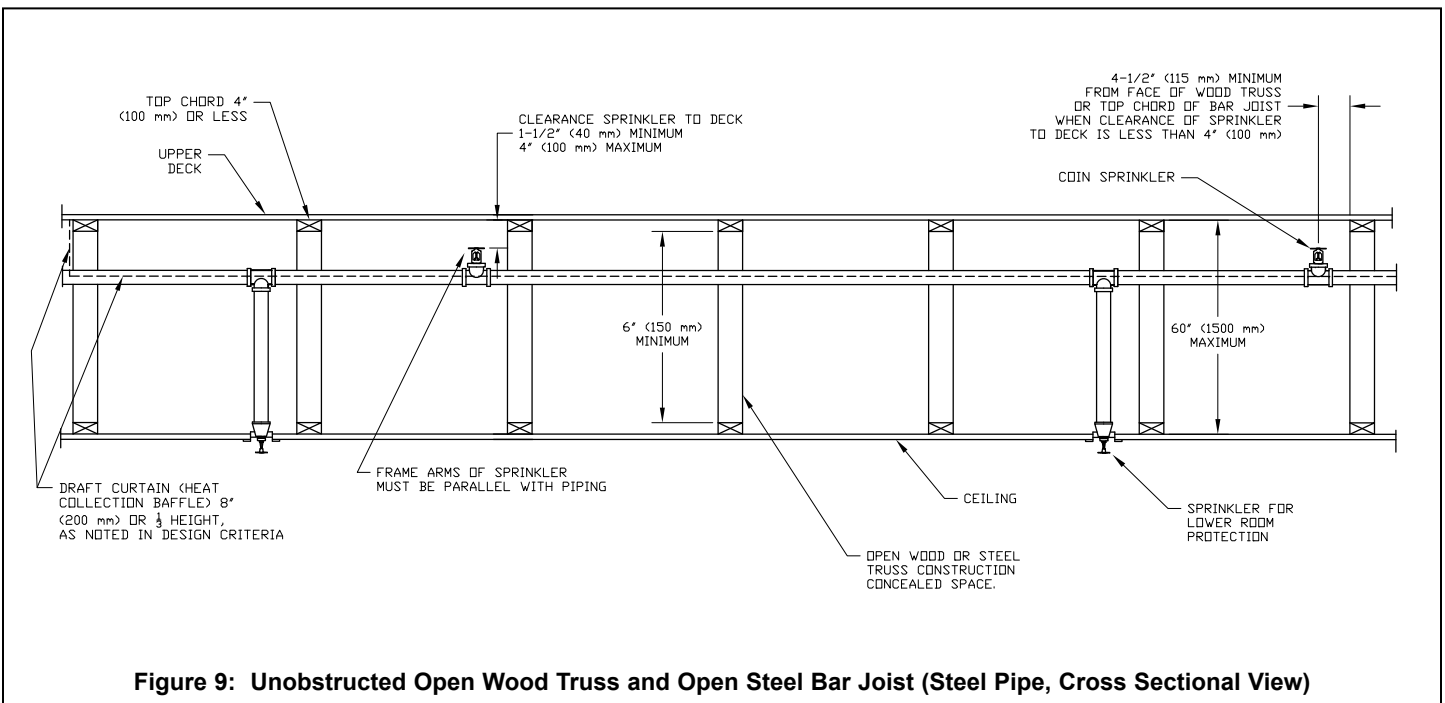

**Figure 9: Unobstructed Open Wood Truss and Open Steel Bar Joist (Steel Pipe, Cross Sectional View)**



**TECHNICAL DATA**

**COIN® QUICK  
RESPONSE UPRIGHT  
SPRINKLER VK950  
(SPECIFIC APPLICATION)**

The Viking Corporation, 210 N Industrial Park Drive, Hastings MI 49058  
 Telephone: 269-945-9501 Technical Services: 877-384-5464 Fax: 269-818-1680 Email: techsvcs@vikingcorp.com  
 Visit the Viking website for the latest edition of this technical data page: www.vikinggroupinc.com

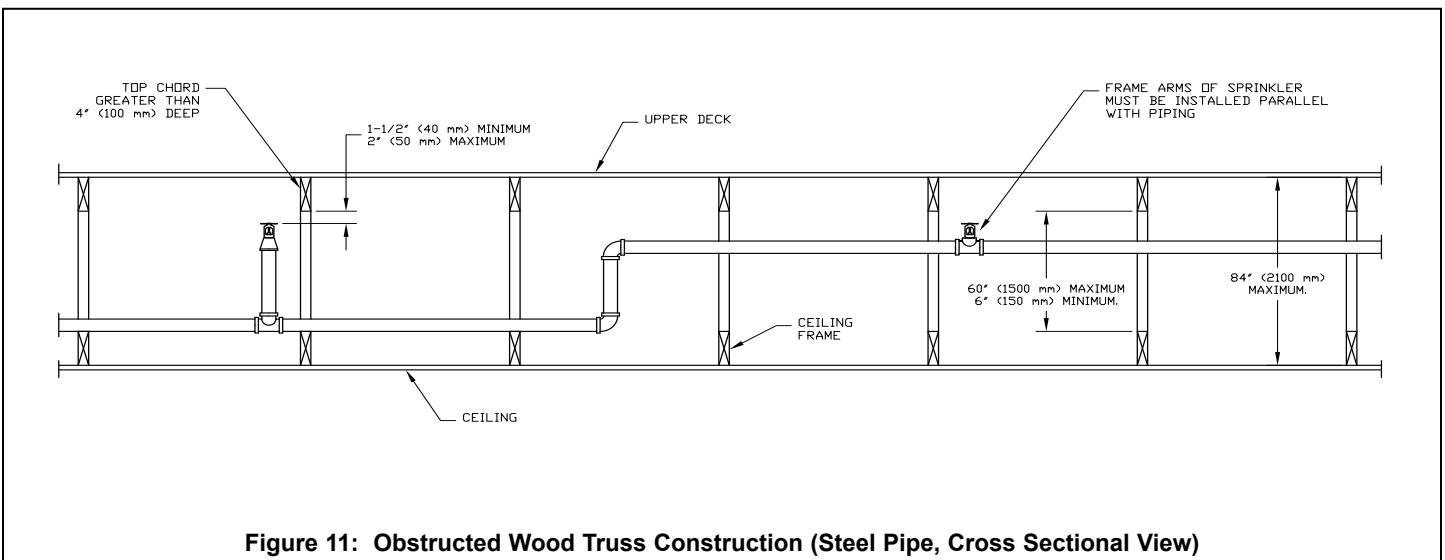
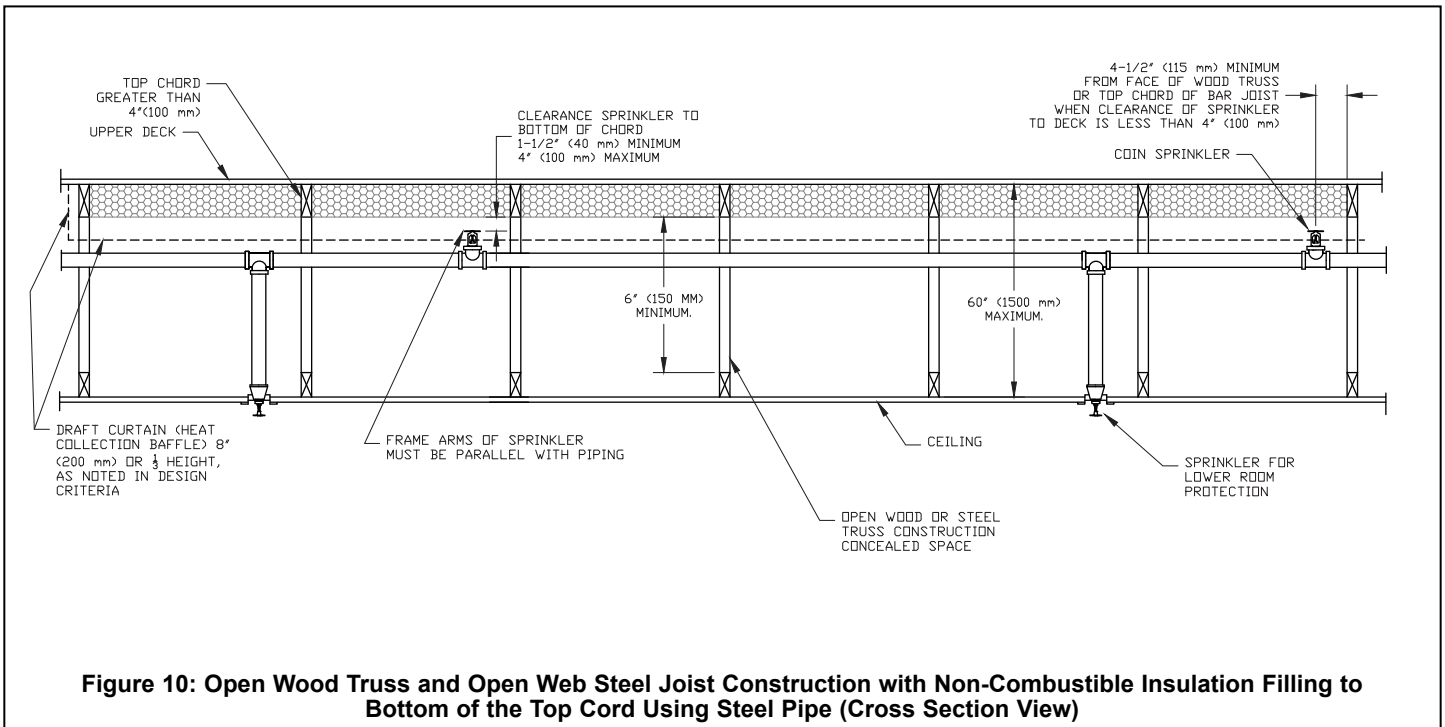



**TECHNICAL DATA**

**COIN® QUICK  
RESPONSE UPRIGHT  
SPRINKLER VK950  
(SPECIFIC APPLICATION)**

The Viking Corporation, 210 N Industrial Park Drive, Hastings MI 49058  
 Telephone: 269-945-9501 Technical Services: 877-384-5464 Fax: 269-818-1680 Email: techsvcs@vikingcorp.com  
 Visit the Viking website for the latest edition of this technical data page: www.vikinggroupinc.com

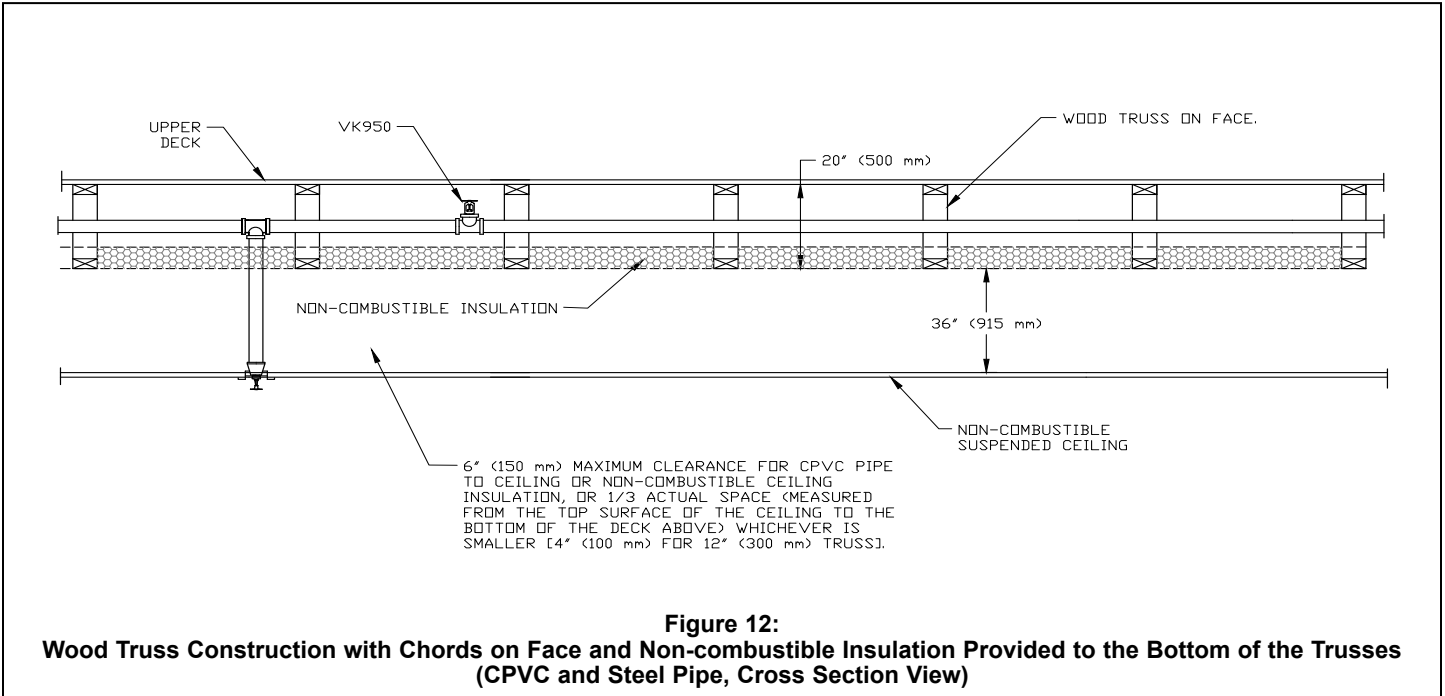



TECHNICAL DATA

COIN® QUICK  
RESPONSE UPRIGHT  
SPRINKLER VK950  
(SPECIFIC APPLICATION)

The Viking Corporation, 210 N Industrial Park Drive, Hastings MI 49058  
Telephone: 269-945-9501 Technical Services: 877-384-5464 Fax: 269-818-1680 Email: techsvcs@vikingcorp.com  
Visit the Viking website for the latest edition of this technical data page: www.vikinggroupinc.com

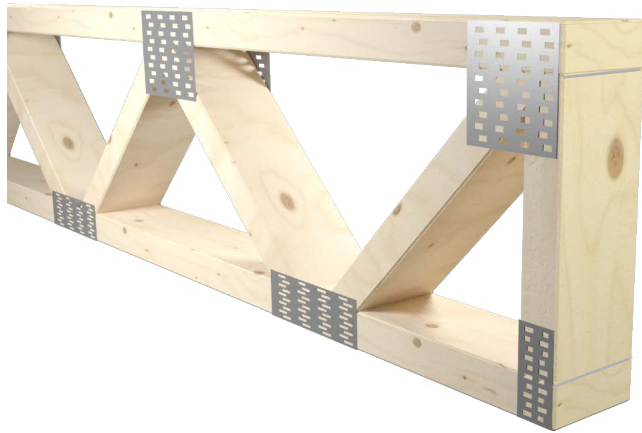

On Face

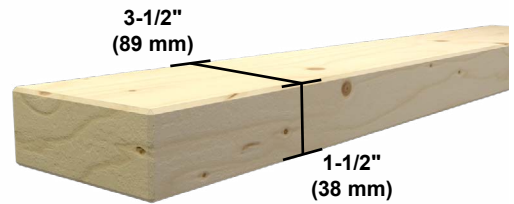

Example of Typical 2x4 Construction  
Refer to Design Criteria

Figure 13A: Trusses on Face

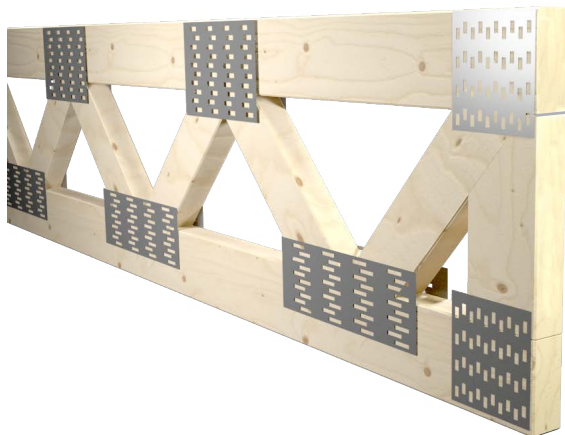

On Edge

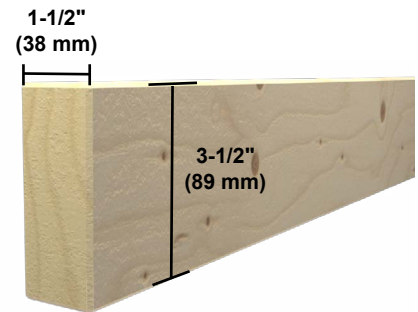

Example of Typical 2x4 Construction  
Refer to Design Criteria



Figure 13B: Trusses on Edge



**TECHNICAL DATA**

**COIN® QUICK  
RESPONSE UPRIGHT  
SPRINKLER VK950  
(SPECIFIC APPLICATION)**

The Viking Corporation, 210 N Industrial Park Drive, Hastings MI 49058  
 Telephone: 269-945-9501 Technical Services: 877-384-5464 Fax: 269-818-1680 Email: techsvcs@vikingcorp.com  
 Visit the Viking website for the latest edition of this technical data page: www.vikinggroupinc.com

**OBSTRUCTION CRITERIA - CPVC and STEEL PIPE**

APPLIES TO BOTH CPVC AND STEEL PIPE (Also refer to the Approval Chart)

**OBSTRUCTIONS**

- All obstruction criteria for extended coverage sprinklers per NFPA 13 shall apply unless specified differently in this data sheet.
- For installations where the VK950 is installed up to a 15'-0" X 15'-0" spacing or less between sprinkler, the obstruction rules for standard coverage sprinklers shall apply.
- For installations where the VK950 exceeds 15'-0" X 15'-0" spacing, and up to 16'-0" X 16'-0" spacing, the obstruction rules for extended coverage sprinklers shall apply
- See illustrations below.

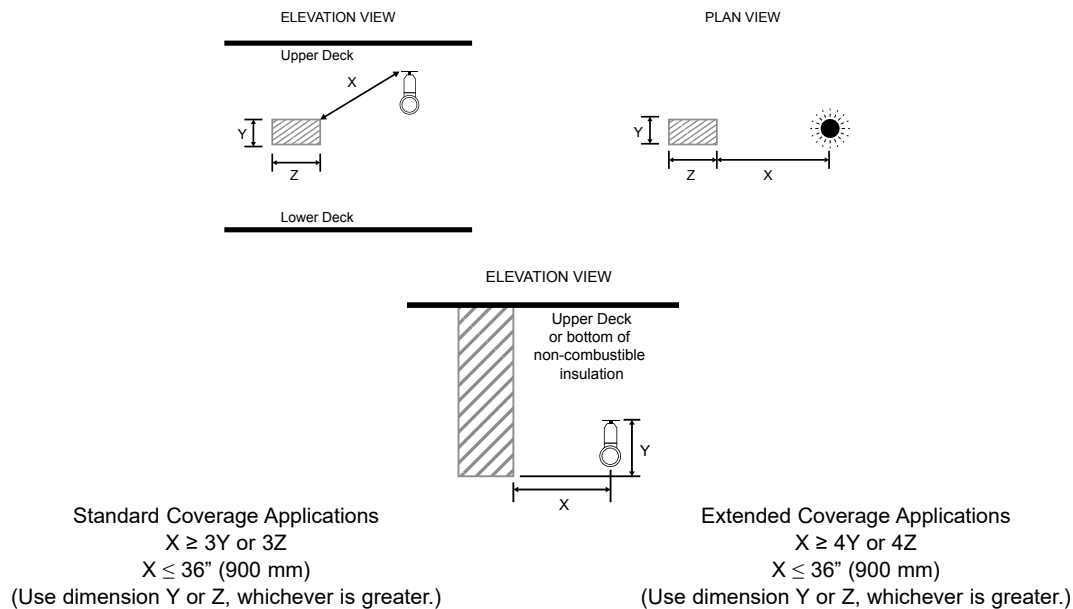

**Figure 14: NFPA 13 Obstruction Criteria**

**NFPA 13 Obstruction Criteria - Standard Coverage Application Table 10.2.7.1.2**

Distance from Sprinkler to Side of Obstruction (X)		Maximum Allowable Distance of Deflector Above Bottom of Obstruction (Y)	
< 1'-0"	<300 mm	0"	0 mm
1'-0" to <1'-6"	300 mm to <450 mm	2½"	65 mm
1'-6" to <2'-0"	450 mm to <600 mm	3½"	90 mm
2'-0" to <2'-6"	600 mm to <750 mm	5½"	140 mm
2'-6" to <3'-0"	750 mm to <900 mm	7½"	190 mm
3'-0" to <3'-6"	900 mm to <1.1 m	9½"	240 mm
3'-6" to <4'-0"	1.1 m to <1.2 m	12"	300 mm
4'-0" to <4'-6"	1.2 m to <1.4 m	14"	350 mm
4'-6" to <5'-0"	1.4 m to <1.5 m	16½"	45 mm

**NFPA 13 Obstruction Criteria - Extended Coverage Application Table 11.2.5.1.2**

Distance from Sprinkler to Side of Obstruction (X)		Maximum Allowable Distance of Deflector Above Bottom of Obstruction (Y)	
< 1'-0"	<300 mm	0"	0 mm
1'-0" to <1'-6"	300 mm to <450 mm	0"	0 mm
1'-6" to <2'-0"	450 mm to <600 mm	1"	25 mm
2'-0" to <2'-6"	600 mm to <750 mm	1"	25 mm
2'-6" to <3'-0"	750 mm to <900 mm	1"	75 mm
3'-0" to <3'-6"	900 mm to <1.1 m	3"	75 mm
3'-6" to <4'-0"	1.1 m to <1.2 m	3"	75 mm
4'-0" to <4'-6"	1.2 m to <1.4 m	5"	125 mm
4'-6" to <5'-0"	1.4 m to <1.5 m	7"	175 mm