



## TECHNICAL DATA

### DOUBLE INTERLOCKED PREACTION SYSTEM WITH ELECTRIC/ PNEU-LECTRIC RELEASE

The Viking Corporation, 210 N Industrial Park Drive, Hastings MI 49058

Telephone: 269-945-9501 Technical Services: 877-384-5464 Fax: 269-818-1680 Email: techsvcs@vikingcorp.com

Visit the Viking website for the latest edition of this technical data page: [www.vikinggroupinc.com](http://www.vikinggroupinc.com)

## 1. DESCRIPTION

(Refer to Figures 1-6.)

Viking Electric/Pneu-Lectric Double Interlocked Preaction Systems utilize a Viking deluge valve, pneumatic supervision of the automatic sprinkler system, and an electric detection system. The deluge valve release trim utilizes a normally closed monitored or non-monitored electric solenoid valve controlled by an approved release control panel with two initiating circuits configured for "cross-zoned" operation. One initiating circuit is connected to the electric detection system; the other to a "low-air" supervisory switch.

BOTH the electric detection system must activate AND supervisory air pressure must be relieved from the sprinkler system before the deluge valve will open to fill the sprinkler system with water. If the electric detection system (alone) operates, an alarm will activate but the deluge valve will NOT open. If the sprinkler piping is damaged or a sprinkler is broken or fused, but the detection system has not activated, an alarm will activate, but the deluge valve will NOT open.

In fire conditions, after both the detection system and a sprinkler operate, the deluge valve opens, allowing water to enter the system. Electric/pneu-lectric double interlocked preaction systems are commonly used as refrigerated area systems. They are also commonly used where flooding of the sprinkler system piping can have serious consequences and where it is important to control accidental water discharge due to damaged sprinkler piping.

## 2. LISTINGS AND APPROVALS



**FM Approved:** Viking Electric/Pneu-Lectric Double-Interlocked Preaction Systems are Factory Mutual (FM) Approved as refrigerated area systems when installed with specific components. Refer to the current FM Approval Guide. Consult the manufacturer for any component approvals too recent to appear in the FM Approval Guide.

## 3. SYSTEM OPERATION

(Refer to Figures 1-6.)

### A. IN THE SET CONDITION

System water supply pressure enters the priming chamber of the deluge valve through the 1/4" (8 mm) priming line, which includes a normally open priming valve (B.1), strainer (B.2), restricted orifice (B.3), and check valve (B.4). In the SET condition, water supply pressure is trapped in the priming chamber by check valve and normally closed monitored or non-monitored solenoid valve (F.1). The water supply pressure trapped in the priming chamber holds the deluge valve clapper closed, keeping the outlet chamber and system piping dry.

### B. IN FIRE CONDITIONS

In a fire condition, operation of the detection system (F.4) activates the first initiating circuit in the system control panel (F.3), causing an alarm to activate. When a sprinkler operates, air pressure escapes from the sprinkler piping. The air supervisory switch (E.3) activates the second initiating circuit in system control panel. When BOTH initiating circuits have been activated, the system control panel energizes the solenoid valve (F.1) open. Pressure is released from the priming chamber to the open drain cup faster than it is supplied through the restricted orifice. The deluge valve (A.1) clapper opens to allow water to flow into the system piping and alarm devices, causing the water motor alarm (C.2) and water flow alarms connected to the alarm pressure switch (C.1) to activate. An optional accelerator may be installed to provide earlier alarms and/or allow the system to fill with water faster. An accelerator may be necessary to meet system water delivery time requirements.

When the deluge valve (A.1) operates, the sensing end of the PORV (B.10) is pressurized, causing the PORV (B.10) to operate. When the PORV (B.10) operates, it continually vents the priming chamber to prevent the deluge valve (A.1) from resetting even if the solenoid valve (F.1) closes. The deluge valve (A.1) can only be reset after the system is taken out of service, and the outlet chamber of the deluge valve (A.1) and associated trim piping are depressurized and drained.

### C. TROUBLE CONDITIONS

If a sprinkler opens prior to operation of the detection system, or any time supervisory pressure in the sprinkler piping is lost, alarms connected to air supervisory switch (E.3) will signal a low-air pressure condition, but the deluge valve will NOT open. If the electric detection system (alone) operates (F.4) due to damage or malfunction, alarms connected to the system control panel (F.3) will activate, but the deluge valve (A.1) will NOT open.

### D. MANUAL OPERATION

Any time the handle inside the emergency release (B.11) is pulled, pressure is released from the priming chamber; the deluge valve (A.1) will open. Water will flow into the system piping and alarm devices. If a sprinkler head opens, water will flow from the system.

## 4. INSTALLATION

Refer to current Viking Technical Data describing individual components of the Viking Electric/Pneu-Lectric Double-Interlocked Preaction System. Technical Data describing the Viking Deluge Valve and other system components are packed with product and in the



**WARNING:** Cancer and Reproductive Harm-  
[www.P65Warnings.ca.gov](http://www.P65Warnings.ca.gov)



# TECHNICAL DATA

## DOUBLE INTERLOCKED PREACTION SYSTEM WITH ELECTRIC/ PNEU-ELECTRIC RELEASE

The Viking Corporation, 210 N Industrial Park Drive, Hastings MI 49058

Telephone: 269-945-9501 Technical Services: 877-384-5464 Fax: 269-818-1680 Email: techsvcs@vikingcorp.com

Visit the Viking website for the latest edition of this technical data page: www.vikinggroupinc.com

**TABLE 1: Recommended Air Pressure Settings**

Device	System Water Pressure	
	Up to 175 PSI (12 bar)	Over 175 PSI (12 bar) to 250 PSI (17 bar)
	Set to Maintain:	
Tank Mounted Air Compressor On/Off Switch	ON: 30 PSI (2 bar) OFF: 40 PSI (2.8 bar)	ON: 50 PSI (3.4) OFF: 60 PSI (4.1 bar)
Air Maintenance Device	30 PSI (2 bar)	50 PSI (3.4 bar)
Low-Air Alarm Contact Setting on Release System Pressure Supervisory Switch	25 PSI (1.7 bar)	45 PSI (3.1 bar)
Setting for Contacts on Release System Pressure Supervisory Switch to activate Release Control Panel Initiating Circuit	20 PSI (1.7 bar)	40 PSI (3.1 bar)

Viking Engineering and Design Data book. Also, refer to applicable installation standards, codes, and Authorities Having Jurisdiction.

### A. IMPORTANT SETTINGS

(Also refer to Table 1 above.)

1. Recommended pneumatic supervisory pressure in the closed sprinkler piping is 30 PSI (2.1 bar). The air supervisory switch (E.3) should be equipped with two sets of independently adjustable contacts. Use Viking Pressure Supervisory Switch Part Number 09473 (or equal) as air supervisory switch.

#### For 30 PSI (2.1 bar) supervisory pressure:

- a. Adjust one set of contacts of air supervisory switch (E.3) to activate at 25 PSI (1.7 bar) on pressure drop. These contacts should be wired to activate a "Low-Air" supervisory alarm.
  - b. The other set of contacts in the air supervisory switch should activate at 20 PSI (1.7 bar) on pressure drop. Wire these contacts to activate the remaining initiating circuit of the system control panel (F.3) configured for "cross-zoned" operation. For the VFR-500 Release Control Panel, refer to the appropriate wiring diagram packed with the panel. Activation of an alarm to signal a high-pressure condition may be required. Refer to applicable installation standards and the Authority Having Jurisdiction.
2. Installation Standards may allow supervisory pressures lower than those recommended above.

#### For 50 PSI (3.4 bar) Supervisory Pressure:

- a. Adjust one set of contacts of air supervisory switch (E.3) to activate at 45 PSI (3.1 bar) on pressure drop. These contacts should be wired to activate a "Low-Air" supervisory alarm.
- b. The other set of contacts in the air supervisory switch should activate at 40 PSI (3.1 bar) on pressure drop. Wire these contacts to activate the remaining initiating circuit of the system control panel (F.3) configured for "cross-zoned" operation. Refer to the appropriate wiring diagram packed with the panel. Activation of an alarm to signal a high-pressure condition may be required. Refer to applicable installation standards and the Authority Having Jurisdiction.

**NOTE: When using supervisory pressures, settings, or equipment other than those recommended above, verify that the air regulation equipment and air supervisory switches used are compatible with the supervisory pressure setting used. Supervisory pressures other than the recommended settings noted above may affect operation of the system.**

3. The alarm pressure switch (C.1) should activate when pressurized to 4 to 8 PSI (0.3 to 0.6 bar) on pressure rise and should be wired to activate the water flow alarm (C.2).

### B. AIR SUPPLY DESIGN

The air supply compressor (G.1) should be sized to establish total required air pressure within 30 minutes. The air supply must be regulated, restricted, and maintained automatically. An air maintenance device (G.6) is used to regulate and restrict the flow of supervisory air into the sprinkler system piping.

**The air supply must be regulated** to maintain the supervisory pressure desired in the sprinkler piping. Pressures other than the pressure settings recommended in section 4. INSTALLATION may affect operation of the system.

**The air supply must be restricted** to ensure that the automatic air supply cannot replace air as fast as it escapes when a sprinkler operates. It is recommended practice to provide an inspector's test connection on the supervised sprinkler piping. For systems in excess of 750 gal (2840 L), a trip test connection must be installed per NFPA 13 on the end of the most distant sprinkler pipe in the upper story, equipped with a readily accessible shutoff valve and plug not less 1" (25 mm), at least one of which shall



## TECHNICAL DATA

### DOUBLE INTERLOCKED PREACTION SYSTEM WITH ELECTRIC/ PNEU-ELECTRIC RELEASE

The Viking Corporation, 210 N Industrial Park Drive, Hastings MI 49058

Telephone: 269-945-9501 Technical Services: 877-384-5464 Fax: 269-818-1680 Email: techsvcs@vikingcorp.com

Visit the Viking website for the latest edition of this technical data page: [www.vikinggroupinc.com](http://www.vikinggroupinc.com)

be brass. The trip test connection shall be not less than 1" (25 mm) in diameter, terminating in a smooth bore corrosion-resistant orifice to provide a flow equivalent to one sprinkler of a type installed on the system.

**Speed of Operation:** An optional accelerator (F.5) may be installed to allow the system to fill with water faster. An accelerator may be necessary to meet water delivery time requirements.

#### Riser-Mounted Compressors:

(Refer to Figures 2, 4, or 6.)

A riser-mounted compressor (G.1) may be suitable for small electrically operated double interlocked preaction systems. However, placement of a dehydrator (G.5) and / or an air maintenance device (G.6) in the outlet piping of a riser-mounted compressor may affect operation of the compressor.

1. When a dehydrator is not installed, verify that the installation is located in a dry environment (not humid) and that the supervised sprinkler piping is never subject to freezing.
2. When an air maintenance device is not used, verify that the air supply produced is properly "regulated" and "restricted". See Air Supply Design paragraphs above, and section 7. INSPECTIONS AND TESTS.
3. DO NOT install an accelerator on the system.
4. Verify system approval. Refer to the Authority Having Jurisdiction.

## 5. PLACING THE SYSTEM IN SERVICE

(Refer to Figures 1-6.)

**NOTE: REFER TO INSTRUCTIONS PROVIDED IN TECHNICAL DATA DESCRIBING THE VIKING DELUGE VALVE AND OTHER SYSTEM COMPONENTS (SEE SECTION 8).**

#### Placing the System to Service:

1. Verify that the system has been properly drained. The system main drain and auxiliary drain should be open. Verify that the emergency release (B.11) is closed.
2. Close the system main drain (D.3).
3. Restore supervisory pressure to sprinkler piping.
4. Establish a normal condition on the release control panel F.3).
  - a. Verify that the ½" valve in the air maintenance device by-pass trim (G.6) is closed and that both 1/4" valves are open.
5. Open the priming valve (B.1).
6. Open the flow test valve (B.15).
7. Partially open the main water supply control valve (D.1).
8. When full flow develops from the flow test valve, close the flow test valve (B.15).
  - a. Verify that there is no flow from the open auxiliary drain (B.6).
9. Fully open and secure the main water supply control valve (D.1).
10. Verify that the alarm shut-off valve (B.9) is open and that all other valves are in their normal operating position.
11. Depress the plunger of the drip check (B.7). No water should flow from the drip check when the plunger is pushed.

## 6. EMERGENCY INSTRUCTIONS (Refer to Figures 1-6.)

### ⚠ WARNING

Any system maintenance that involves placing a control valve or detection system out of service will impair the fire protection capabilities of that system. Prior to proceeding, appropriate impairment procedures per NFPA 25 shall be followed with the notification of all Authorities Having Jurisdiction. Consideration should be given to employment of a fire patrol in the affected areas.

**Failure to follow these instructions could cause improper system operation, resulting in serious personal injury and/or property damage.**

#### To Take System Out of Service:

After a fire, verify that the fire is OUT and that placing the system out of service has been authorized by the appropriate Authority Having Jurisdiction.

1. Close the water supply valve (D.1).
2. Open the system main drain (D.3).



## TECHNICAL DATA

### DOUBLE INTERLOCKED PREACTION SYSTEM WITH ELECTRIC/ PNEU-LECTRIC RELEASE

The Viking Corporation, 210 N Industrial Park Drive, Hastings MI 49058

Telephone: 269-945-9501 Technical Services: 877-384-5464 Fax: 269-818-1680 Email: techsvcs@vikingcorp.com  
Visit the Viking website for the latest edition of this technical data page: www.vikinggroupinc.com

3. Silence alarms (optional).
  - a. To silence electric alarms controlled by the Viking VFR-500 Release Control Panel (F.3), open the panel and press "ALARM SILENCE"
  - b. To silence electric alarms controlled by the pressure switch (C.1) and to silence the water motor alarm (C.2), close the alarm shut-off valve (B.9).

**NOTE: ELECTRIC ALARMS CONTROLLED BY A PRESSURE SWITCH (G.2) INSTALLED IN THE ½" (15 MM) NPT CONNECTION FOR A NON-INTERRUPTIBLE ALARM PRESSURE SWITCH CANNOT BE SHUT OFF UNTIL THE DELUGE VALVE IS RESET OR TAKEN OUT OF SERVICE.**

4. Shut off the air supply (optional) (G.4).
5. Open the auxiliary drain (B.6).

#### ⚠ WARNING

Sprinkler systems that have been subject to a fire must be returned to service as soon as possible. The entire system must be inspected for damage and repaired or replaced as necessary.

6. Replace any detectors that have been damaged.
7. Replace any sprinklers that have opened, that have been damaged, or have been exposed to fire conditions.
8. Perform all maintenance procedures recommended in technical data describing individual components of the system that has operated.
9. Return the system to service as soon as possible. Refer to section 5. PLACING THE SYSTEM IN SERVICE.

## 7. INSPECTIONS AND TESTS

#### NOTICE

**The owner is responsible for maintaining the fire protection system and devices in proper operating condition.**

It is imperative that the system be inspected and tested on a regular basis in accordance with NFPA 25. Refer to INSPECTIONS and TESTS recommended in current Viking Technical Data describing individual components of the Viking Electric/Pneu-Lectric Double-Interlocked Preaction System used.

The frequency of the inspections may vary due to contaminated water supplies, corrosive water supplies, corrosive atmospheres, as well as the condition of the air supply to the system. For minimum maintenance and inspection requirements, refer to NFPA 25. In addition, the Authority Having Jurisdiction may have additional maintenance, testing, and inspection requirements that must be followed.

#### ⚠ WARNING

Any system maintenance that involves placing a control valve or detection system out of service will impair the fire protection capabilities of that system. Prior to proceeding, appropriate impairment procedures per NFPA 25 shall be followed with the notification of all Authorities Having Jurisdiction. Consideration should be given to employment of a fire patrol in the affected areas.  
**Failure to follow these instructions could cause improper system operation, resulting in serious personal injury and/or property damage.**

#### Low-Air Pressure Alarm Test:

Quarterly testing of low air alarms is recommended.

#### **To Test Sprinkler System "Low Supervisory Air" Alarm:**

1. To prevent operation of the deluge valve and filling the system with water during the test, DO NOT operate the electric detection system during this test. Consider closing the main water supply control valve (D.1).
2. Fully open the sprinkler system trip test connection to simulate operation of a sprinkler.
3. Verify that low-air alarms operate within an acceptable time period and continue without interruption.
4. Close the trip test connection valve.
5. Establish pneumatic supervisory pressure to be maintained. Refer to section 4. INSTALLATION.
6. Open the system control panel (F.3) and press RESET. Alarms should stop.

**When testing is complete, return the system to service following steps 1 through 9 below.**



## TECHNICAL DATA

### DOUBLE INTERLOCKED PREACTION SYSTEM WITH ELECTRIC/ PNEU-LECTRIC RELEASE

The Viking Corporation, 210 N Industrial Park Drive, Hastings MI 49058

Telephone: 269-945-9501 Technical Services: 877-384-5464 Fax: 269-818-1680 Email: techsvcs@vikingcorp.com

Visit the Viking website for the latest edition of this technical data page: [www.vikinggroupinc.com](http://www.vikinggroupinc.com)

#### **CAUTION**

This procedure applies only when done in conjunction with “low air” alarm testing described above.

If the main water supply valve (D.1) was closed in step 1 above, proceed with steps 1 through 9 below.

1. Verify that the pressure indicated on the priming pressure water gauge (B.12) indicates that the priming chamber is pressurized with system water supply pressure.

2. Depress the plunger of the drip check (B.7). No water should flow from the drip check when the plunger is pushed.

If the main water supply control valve (D.1) was NOT closed in step 1, proceed to step 8 below.

If the main water supply control valve WAS closed in step 1, proceed with steps 3 through 9 below.

3. Open the flow test valve (B.15) and auxiliary drain.

4. Partially open the main water supply control valve (D.1).

5. When full flow develops from the flow test valve, close the flow test valve.

a. Verify that there is no flow from the open auxiliary drain (B.6).

6. Close the auxiliary drain.

7. Fully open and secure the main water supply control valve (D.1).

8. Verify that the alarm shut-off valve (B.9) is open and that all other valves are in their normal operating position.

9. Depress the plunger of the drip check (B.7). No water should flow from the drip check when the plunger is pushed.

#### **Full-Flow Trip Test:**

Performance of a trip test is recommended annually during warm weather. Consider coordinating this test with operation testing of the detectors.

#### **CAUTION**

Performing a trip test results in operation of the deluge valve. Water will flow into the sprinkler piping. Take necessary precautions to prevent damage.

#### **To Trip Test the Electrically Controlled Double-Interlocked Preaction System:**

1. Notify the Authority Having Jurisdiction and those in the area affected by the test.

2. Trip the deluge valve:

a. Operate a detector according to the manufacturer's instructions.

b. Open the sprinkler system inspector's test connection.

3. The deluge valve should open, filling the sprinkler system with water.

a. Waterflow alarms should operate.

4. Verify adequate flow from the sprinkler system inspector's test valve within an acceptable time period.

#### **When Trip Testing is Complete:**

5. Perform steps 1 through 10 of section 6. EMERGENCY INSTRUCTIONS to take the system out of service.

6. Perform steps 1 through 12 of section 5. PLACING THE SYSTEM IN SERVICE to return the system to service.

7. Notify the Authority Having Jurisdiction and those in the affected area that testing is complete.

## 8. ORDERING INSTRUCTIONS

To order a complete Double-Interlocked Preaction System with Electric/Pneu-Lectric Release, the following components must be purchased: Deluge Valve, Conventional Trim, and a Release Trim package.



# TECHNICAL DATA

**DOUBLE INTERLOCKED  
PREACTION SYSTEM  
WITH ELECTRIC/  
PNEU-ELECTRIC RELEASE**

The Viking Corporation, 210 N Industrial Park Drive, Hastings MI 49058

Telephone: 269-945-9501 Technical Services: 877-384-5464 Fax: 269-818-1680 Email: techsvcs@vikingcorp.com

Visit the Viking website for the latest edition of this technical data page: www.vikinggroupinc.com

## VALVE PART NUMBERS

Straight-Through Valves				
DESCRIPTION		NOMINAL SIZE	PART NUMBERS	
			Painted Red	HALAR®
Threaded NPT	<b>Pipe O.D.</b>		<b>Model F-1</b>	<b>Model F-2</b>
	NPT 48 mm	1½"	12126	----
	NPT 60 mm	2"	12059	----
	NPT 65 mm	2½"	12401	12402Q/B
	BSP 48 mm	DN40	12682	----
	BSP 60 mm	DN50	12686	----
Flange/ Flange	<b>Flange Drilling</b>		<b>Model F-1</b>	<b>Model F-2</b>
	ANSI	3"	12014	12015Q/B
	ANSI	4"	11953	11960Q/B
	ANSI	6"	11955	11962Q/B
	ANSI	8"	11991	11992Q/B
	ANSI/Japan	6"	11964	----
	PN10/16	DN80	12026	12027Q/B
	PN10/16	DN100	11965	11966Q/B
	PN10/16	DN150	11956	11963Q/B
	PN10	DN200	11995	11996Q/B
Flange/ Groove	<b>Flange Drilling / Pipe O.D.</b>		<b>Model F-1</b>	<b>Model F-2</b>
	ANSI / 89 mm	3"	12018	12019Q/B
	ANSI / 114 mm	4"	11952	11959Q/B
	ANSI / 168 mm	6"	11954	11961Q/B
	PN10/16 / 89 mm	DN80	12030	12644Q/B
	PN10/16 / 114 mm	DN100	11958	12645Q/B
	PN10/16 / 165 mm	DN150	12640	12641Q/B
	PN10/16 / 168 mm	DN150	11954	11961Q/B
Groove/ Groove	<b>Pipe O.D.</b>		<b>Model F-1</b>	<b>Model F-2</b>
	48 mm	1½" / DN40	12125	12127Q/B
	60 mm	2" / DN50	12057	12058Q/B
	73 mm	2½" / DN65	12403	12404Q/B
	76 mm	DN80	12729	12730Q/B
	89 mm	3" / DN80	12022	12023Q/B
	114 mm	4" / DN100	11513	11514Q/B
	165 mm	DN150	11910	11911Q/B
	168 mm	6" / DN150	11524	11525Q/B
219 mm	8" / DN200	11018	11118Q/B	



# TECHNICAL DATA

## DOUBLE INTERLOCKED PREACTION SYSTEM WITH ELECTRIC/ PNEU-ELECTRIC RELEASE

The Viking Corporation, 210 N Industrial Park Drive, Hastings MI 49058

Telephone: 269-945-9501 Technical Services: 877-384-5464 Fax: 269-818-1680 Email: techsvcs@vikingcorp.com

Visit the Viking website for the latest edition of this technical data page: www.vikinggroupinc.com

### VALVE TRIM PACKAGE PART NUMBERS

DESCRIPTION		NOMINAL SIZE	PART NUMBERS	
Use with Straight- Through Valves	Horizontal Arrangement		Galvanized	Brass
		1½" / DN40	14635-1	14635-2
		2" / DN50	14635-1	14635-2
		2½" / DN65	14637-1	14637-2
		3" / DN80	14637-1	14637-2
		4" / DN100	14638-1	14638-2
		6" / DN150	14640-1	14640-2
	8" / DN200	14643-1	14643-2	
	Vertical Arrangement	1½" / DN40	14634-1	14634-2
		2" / DN50	14634-1	14634-2
		2½" / DN65	14636-1	14636-2
		3" / DN80	14636-1	14636-2
		4" / DN100	14639-1	14639-2
		6" / DN150	14641-1	14641-2
8" / DN200		14642-1	14642-2	

### CHECK VALVE PART NUMBERS

DESCRIPTION		NOMINAL SIZE	PART NUMBER	
<b>IN-LINE CHECK VALVE</b>				
Groove / Groove		<b>Model L-1</b>		
		1-1/2" / DN40	11054	
		2" / DN50	11059	
Threaded NPT		<b>Model K-1</b>	10659	
		1-1/2" / DN40	10667	
		2" / DN50		
<b>EASY RISER® SWING CHECK VALVE</b>				
Flange/Flange	<b>Flange Drilling</b>	<b>Model F-1</b>		
	ANSI	3"	08505	
	ANSI	4"	08508	
	ANSI	6"	08511	
	ANSI/Japan	DN100	09039	
	ANSI/Japan	DN150	09385	
	ANSI/Japan	DN200	14023	
	PN10/16	DN80	08796	
	PN10/16	DN100	08797	
	PN10/16	DN150	08835	
	PN10	DN200	08836	
	PN16	DN200	12355	
	Flange/Groove	<b>Flange Drilling / Pipe O.D.</b>	<b>Model F-1</b>	
		ANSI / 89mm	3"	08506
		ANSI / 114 mm	4"	08509
ANSI / 168 mm		6"	08512	
ANSI / 219 mm		8"	08515	
PN10/16 / 89 mm		DN80	12648	
PN10/16 / 114 mm		DN100	12649	
PN10/16 / 165 mm		DN150	12652	
PN10/16 / 168 mm		DN150	08512	
PN10 / 219 mm		DN200	12651	
PN16 / 219 mm		DN200	12650	
Groove/Groove		<b>Pipe O.D.</b>	<b>Model E-1</b>	
	73 mm	2½" / DN65	07929	
		<b>Model F-1</b>		
	89 mm	3" / DN80	08507	
	114 mm	4" / DN100	08510	
	165 mm	DN150	12356	
	168 mm	6" / DN150	08513	
219 mm	8" / DN200	08516		

### RELEASE CONTROL PANEL PART NUMBERS

DESCRIPTION	PART NUMBERS
VFR-500	26107

### AIR MAINTENANCE DEVICE AND SUPERVISORY SWITCH PART NUMBERS

DESCRIPTION	MODEL	PART NUMBER
<b>AIR PRESSURE MAINTENANCE DEVICE Complete with Trim</b>	D-2	07459
<b>PRESSURE SUPERVISORY SWITCH Adjustable Range 10-175 PSI (0.7-12 bar)</b>	1/2" / DN15	
	Single SPDT	PS40-1A
	Dual SPDT	PS40-2A

### CHECK VALVE TRIM PACKAGE PART NUMBERS

DESCRIPTION	NOMINAL SIZE	PART NUMBER
Check Valve Trim	1½" / DN40	12960
	2" / DN50	12960
	2½" / DN65	13776
	3", 4", 6", 8" / DN80, DN100, DN150, DN200	13777

### RELEASE TRIM PACKAGE PART NUMBERS

DESCRIPTION	PART NUMBERS	
Release Trim	Galvanized	Brass
	10830	10832
Monitored Solenoid Valve	26785	
Solenoid Valve	11601	



# TECHNICAL DATA

## DOUBLE INTERLOCKED PREACTION SYSTEM WITH ELECTRIC/ PNEU-ELECTRIC RELEASE

The Viking Corporation, 210 N Industrial Park Drive, Hastings MI 49058

Telephone: 269-945-9501 Technical Services: 877-384-5464 Fax: 269-818-1680 Email: techsvcs@vikingcorp.com

Visit the Viking website for the latest edition of this technical data page: www.vikinggroupinc.com

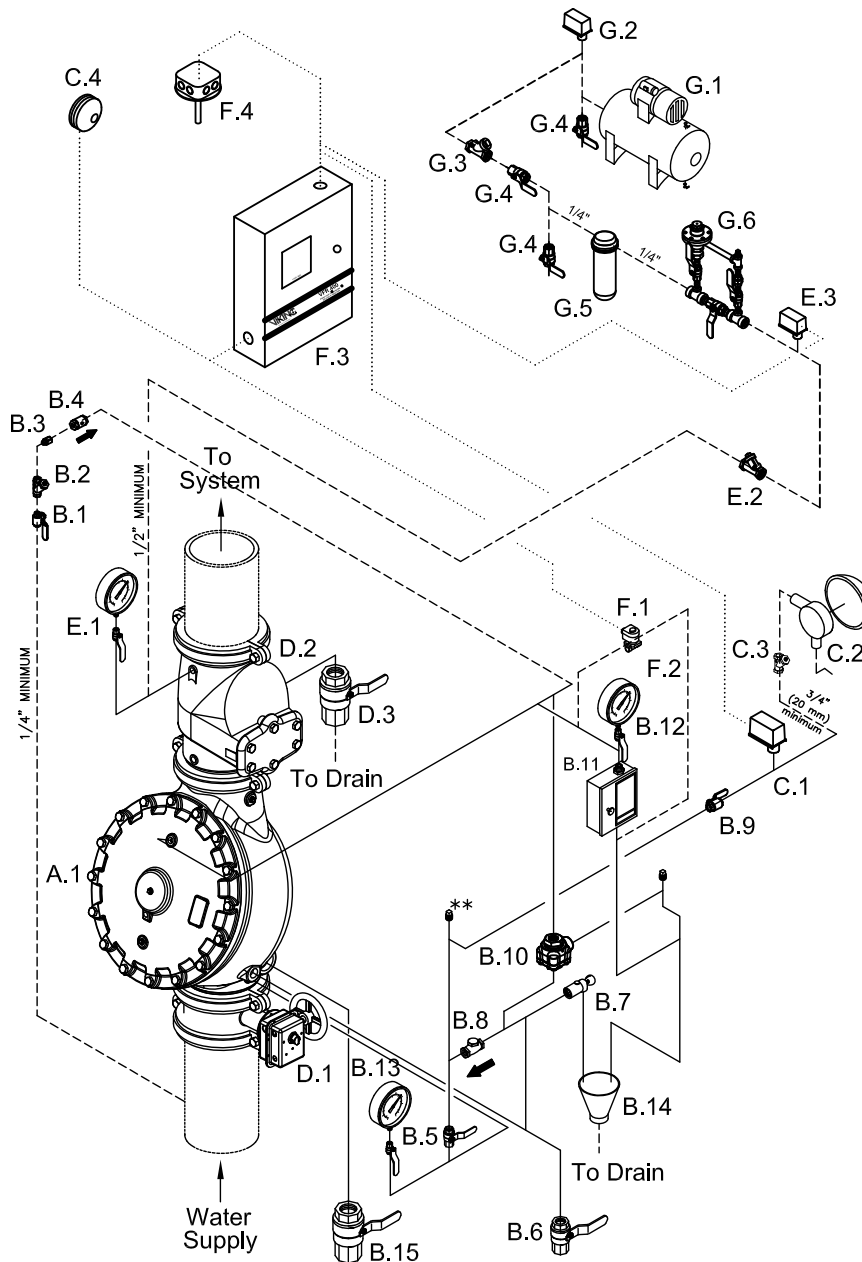

### SYSTEM COMPONENTS

- A. Valve  
A.1 Deluge Valve
- B. Deluge Valve Conventional Trim \*
- (See Deluge Valve Conventional Trim Charts)
- B.1 Priming Valve (Normally Open)  
B.2 Strainer  
B.3 1/16" Restricted Orifice  
B.4 Spring Loaded Check Valve  
B.5 Alarm Test Valve (Normally Closed)  
B.6 Auxiliary Drain Valve (Normally Closed)  
B.7 Drip Check Valve  
B.8 Drain Check Valve  
B.9 Alarm Shut-Off Valve (Normally Open)  
B.10 Pressure Operated Relief Valve (PORV)  
B.11 Emergency Release  
B.12 Priming Pressure Water Gauge and Valve  
B.13 Water Supply Pressure Gauge and Valve  
B.14 Drain Cup  
B.15 Flow Test Valve (Normally Closed)
- C. Water Flow Alarm Equipment  
C.1 Alarm Pressure Switch and/or  
C.2 Water Motor Alarm (Strainer Required)  
C.3 Strainer  
C.4 Electric Alarm Bell
- D. Riser  
D.1 Water Supply Control Valve  
D.2 Easy Riser Check Valve or rubber seated check valve  
D.3 Sprinkler System Main Drain
- E. Supervisory Air Supply  
E.1 System Pressure Gauge and Valve  
E.2 Soft Seat Swing Check Valve  
E.3 Air Pressure Supervisory Switch
- F. Release System  
F.1 Solenoid Valve (Normally Closed)  
F.2 Electric Release Trim  
F.3 System Control Panel configured for Non-Interlocked Preaction operation.  
F.4 Electric Detection System. Heat Detector shown for clarity.
- G.1 Automatic Air Supply. Air Compressor and Tank shown for clarity.  
G.2 Air Supervisory Pressure Switch (Compressor On/Off Control Switch)  
G.3 Soft Seat Check Valve  
G.4 Shut Off Valve (Indicating Ball Valve recommended.)  
G.5 Dehydrator  
G.6 Air maintenance Device & By-Pass Trim

----- Dashed lines indicate pipe is required but not listed in the "System Components" Table.

..... Dotted lines indicate electrical detection system wiring is required, but is not listed in the "System Components" Table. For additional wiring requirements, refer to technical data for components used.

\* Viking Deluge Valve Trim Packages contain items B.1 through B.15 and associated nipples. Viking Accessory Package for Conventional Deluge Valve Trim contains items B.2 through B.5, B.7 through B.11, and B.14.

\*\* 1/2" (15 mm) NPT for Non-Interruptible Alarm Pressure Switch (Optional).

**FIGURE 1: VERTICAL DELUGE VALVE WITH TANK-MOUNTED COMPRESSOR  
(6" Valve Shown)**



# TECHNICAL DATA

## DOUBLE INTERLOCKED PREACTION SYSTEM WITH ELECTRIC/ PNEU-ELECTRIC RELEASE

The Viking Corporation, 210 N Industrial Park Drive, Hastings MI 49058

Telephone: 269-945-9501 Technical Services: 877-384-5464 Fax: 269-818-1680 Email: techsvcs@vikingcorp.com

Visit the Viking website for the latest edition of this technical data page: [www.vikinggroupinc.com](http://www.vikinggroupinc.com)

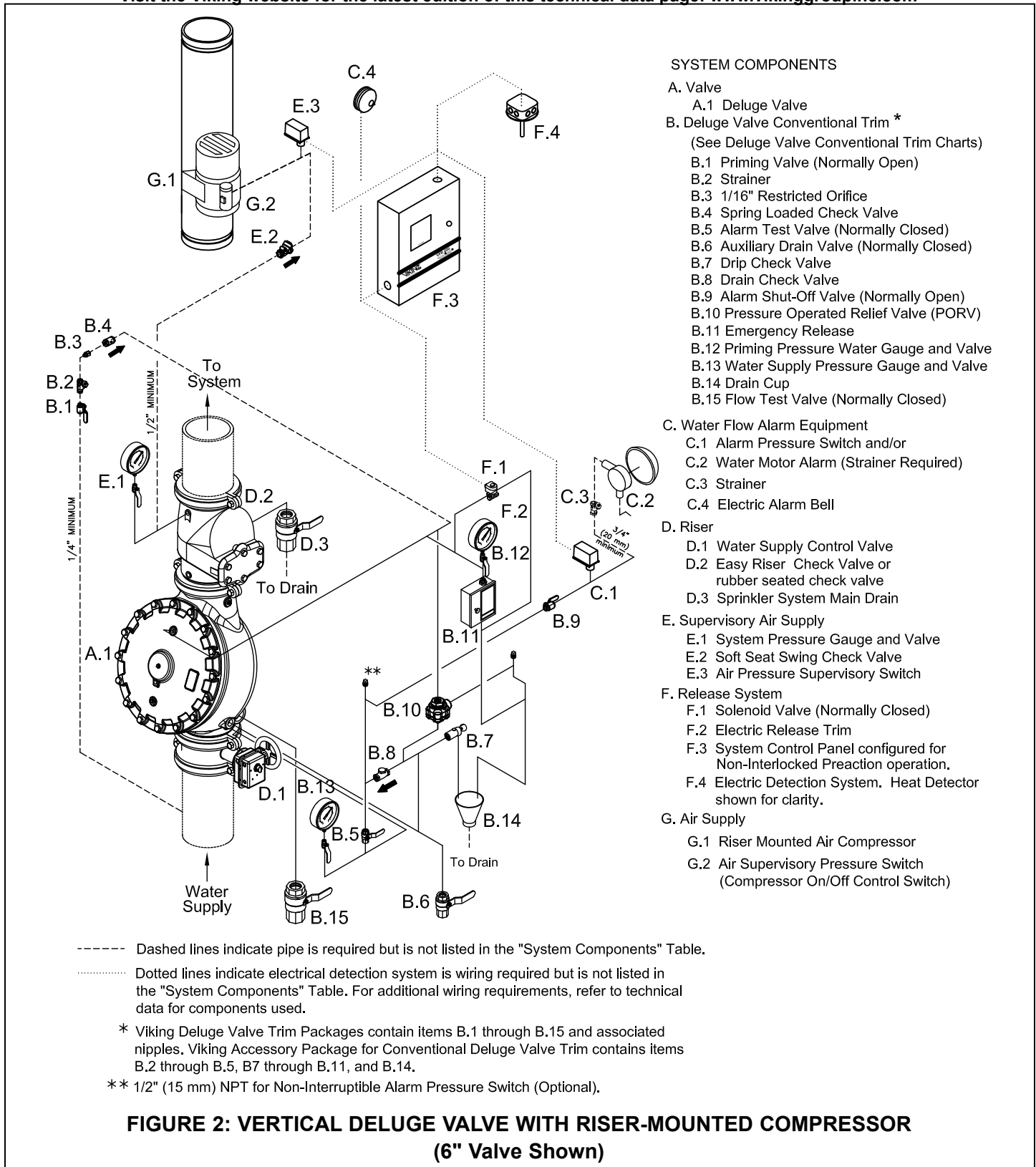



# TECHNICAL DATA

## DOUBLE INTERLOCKED PREACTION SYSTEM WITH ELECTRIC/ PNEU-ELECTRIC RELEASE

The Viking Corporation, 210 N Industrial Park Drive, Hastings MI 49058

Telephone: 269-945-9501 Technical Services: 877-384-5464 Fax: 269-818-1680 Email: techsvcs@vikingcorp.com

Visit the Viking website for the latest edition of this technical data page: www.vikinggroupinc.com

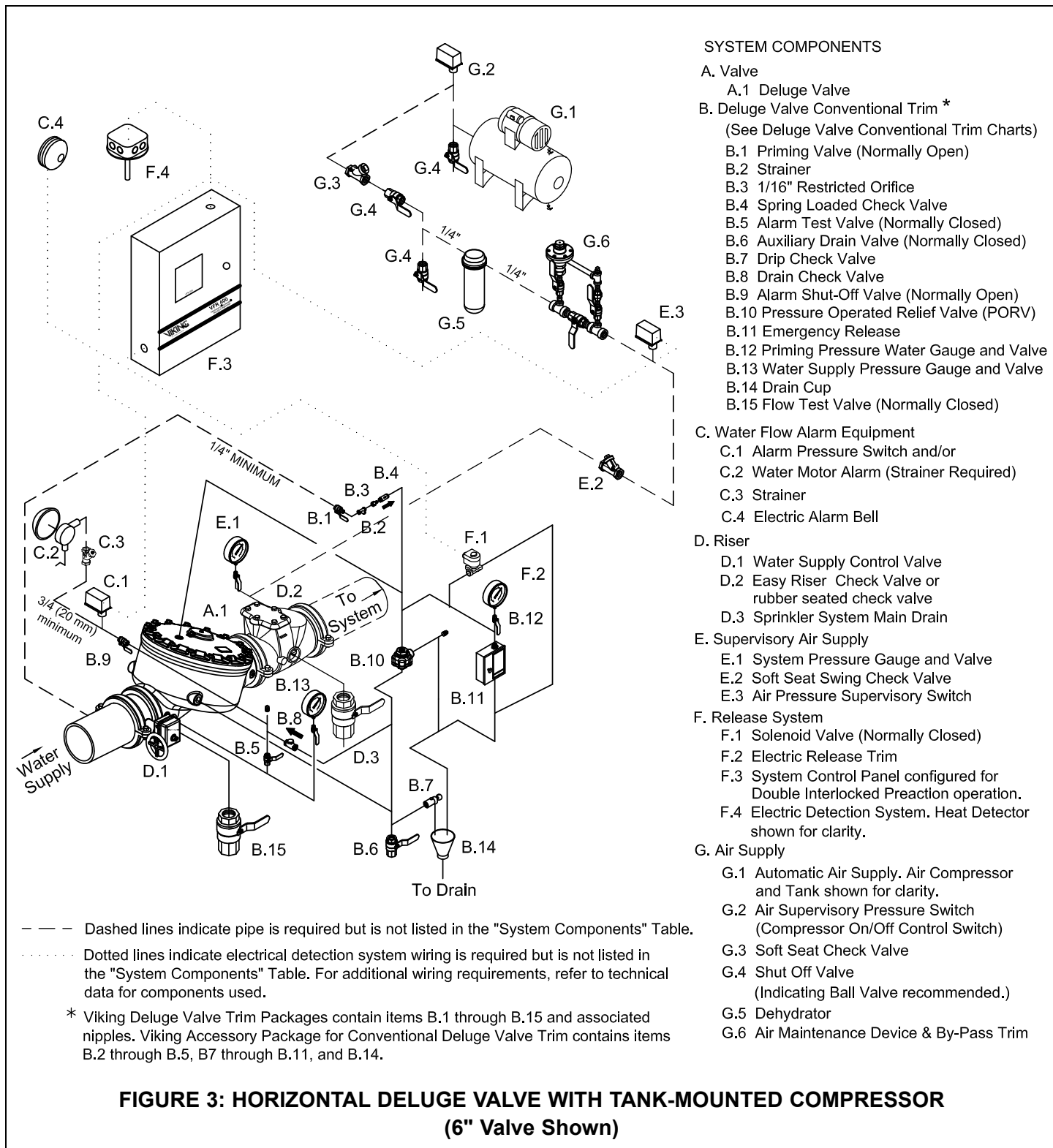



# TECHNICAL DATA

## DOUBLE INTERLOCKED PREACTION SYSTEM WITH ELECTRIC/PNEU-ELECTRIC RELEASE

The Viking Corporation, 210 N Industrial Park Drive, Hastings MI 49058

Telephone: 269-945-9501 Technical Services: 877-384-5464 Fax: 269-818-1680 Email: techsvcs@vikingcorp.com  
 Visit the Viking website for the latest edition of this technical data page: www.vikinggroupinc.com

