



TECHNICAL DATA

TRIMPAC® MODEL B-3 & B-3B SINGLE INTERLOCK PREACTION SYSTEM WITH ELECTRIC RELEASE

The Viking Corporation, 210 N Industrial Park Drive, Hastings MI 49058

Telephone: 269-945-9501 Technical Services: 877-384-5464 Fax: 269-818-1680 Email: techsvcs@vikingcorp.com

Visit the Viking website for the latest edition of this technical data page: www.vikinggroupinc.com

1. DESCRIPTION

TRIMPAC® Model B-3 & B-3B is a factory assembled trim package for a single interlocked preaction system with electric release module in a metal enclosure. The standard trim normally required on a deluge valve has been moved to a single cabinet. TRIMPAC® Model B-3 & B-3B provides access doors for the emergency release (B.1) and alarm test valve (B.7) for manual operation of these trim valves. TRIMPAC® Model B-3 & B-3B is equipped with priming water pressure and water supply gauge view-ports for easy monitoring of water pressures, and with a monitored solenoid (NC) and a non-monitored solenoid (NC). TRIMPAC® Model B-3 & B-3B eliminates the installation of alarm trim piping and release trim piping at the deluge valve. The enclosure protects trim valves from inadvertent operation. The included stainless steel hoses (or field provided hard piping) from the valve body to the enclosure assembly allows the assembly to be installed remote of the sprinkler system riser. TRIMPAC® Model B-3 & B-3B can be utilized for systems regardless of valve size. A valve drain package for the deluge valve is required and is ordered based on the deluge valve size. See Figures 12 and 13 for drain trim charts.



WARNING: Cancer and Reproductive Harm-
www.P65Warnings.ca.gov

2. LISTINGS AND APPROVALS



cULus Listed - VLTR & VLTR7



FM Approved - Preaction Sprinkler Systems

3. TECHNICAL DATA

Specifications:

Rated Water Working Pressure: 250 psi (17.2 bar)

Gauges: 0-300 PSI (0-20.7 bar)

Weight: 34 lbs. (15.4 kg.)

Dimensions: 16-1/8" (409 mm) high x 29-1/8" (748 mm) wide x 8-25/32" (223 mm) deep

Material Standards:

Enclosure: 16 gauge steel, painted red: Epoxy Powder Coat

Gauges: Brass 1/4" NPT, Plastic Body

PORV: Brass Body, 250 PSI (17.2 bar), 1/2" NPT inlet, 1/2" NPT drain, 1/2" NPT sensing side

Solenoid Valve:

- Monitored Solenoid (NC): Brass body, 24 VDC, 5-300 PSI (0.34-20.7 bar), NEMA Rated 2, 3, 3S, 4, 4X, 9.0 Watts
- Non-Monitored Solenoid (NC): Brass Body 1/2" (1.27 cm), 24 Volt DC, 250 psi (17.2 bar) NEMA Rated 1, 2, 3, 3S, 4 or 4X, 9 Watts

Ball Valves: 1/2" NPT female ends

Strainer: Brass Body, 1/2" NPT inlet and outlet, 50 mesh screen

Restricted Orifice: Brass Body, 1/2" NPT male inlet and outlet, 0.0625" orifice

Spring Loaded Check Valve: Brass Body, 1/2" NPT female inlet and outlet

Drain Check Valve: Brass Body, 1/2" NPT female inlet and outlet, EPDM clapper rubber

Hoses (4): Flexible braided stainless steel hoses with steel fittings and connectors, PTFE lined

Drain Hose (1): PVC Hose 60" long with brass hose connector x 1/2" NPT

Trim Piping: 1/2" Galvanized or 1/2" brass

Fittings: 1/2" Galvanized

Ordering Information: Refer to Table 1.

Accessories:

1. Vertical Mounting Plate Kit - Part No. 11900
2. Horizontal Mounting Plate Kit - Part No. 11901
3. Hose Assembly Kit (Includes (4) Stainless Steel Hoses and (1) PVC Drain Hose) - Part No. 12072
4. Individual 5'-0" Stainless Steel & PTFE Hose: Part No. 16558 (4) (included with Part Nos. 13792B-3 and 13792B-3B)
5. Individual PVC Hose: Part No. 12071 (1) (included with Part Nos. 13792B-3 and 13792B-3B)



TECHNICAL DATA

TRIMPAC® MODEL B-3 & B-3B SINGLE INTERLOCK PREACTION SYSTEM WITH ELECTRIC RELEASE

The Viking Corporation, 210 N Industrial Park Drive, Hastings MI 49058

Telephone: 269-945-9501 Technical Services: 877-384-5464 Fax: 269-818-1680 Email: techsvcs@vikingcorp.com

Visit the Viking website for the latest edition of this technical data page: www.vikinggroupinc.com

4. INSTALLATION (Refer to Figures 3 - 10 for identification of trim components. Refer to Figure 11 for wall-mounting.)

1. TRIMPAC® Model B-3 & B-3B Trim Assemblies may be installed with the straight-through style Model F Deluge Valves, sizes 1-1/2", 2", 3", 4", 6", and 8".
2. **TRIMPAC® Model B-3 & B-3B trim assembly and valve must be installed in an area not subject to freezing.**
3. **TRIMPAC® Model B-3 & B-3B trim assembly must be installed to facilitate drainage.**
4. **TRIMPAC® Model B-3 & B-3B trim assembly must be installed above the elevation of the drip check valve (C.2).**
5. TRIMPAC® Model B-3 & B-3B Trim Assembly can be installed with the furnished hose package or 1/2" non-corrosive metallic piping. The maximum distance the TRIMPAC® Model B-3 & B-3B may be installed away from the deluge/flow control valve is 5'-0".
6. The deluge valve equipped with TRIMPAC® Model B-3 & B-3B must be installed in accordance with Viking Technical data. The required drain package must be installed in accordance with Figures 12 and 13.
 - a. Remove all plastic thread protectors from the openings of the deluge/flow control valve and the TRIMPAC® Model B-3 & B-3B trim assembly.
 - b. Apply a small amount of pipe-joint compound or tape to the external threads of all pipe connections required. Take care not to allow any compound, tape, or other foreign matter inside any of the nipples or openings of the valve or trim components.
 - c. Verify that all system components are rated for the water working pressure of the system.

Hydrostatic Test:

The Viking deluge valve is manufactured and listed for use at a maximum Water Working Pressure of 250 PSI (17.2 bar). The valve is factory tested at 500 psi (34.5 bar). The Viking deluge/flow control valve may be hydrostatically tested at 300 PSI (20.7 bar) and/or 50 PSI (3.5 bar) above the normal Water Working Pressure, for limited periods of time (2 hours) for the purpose of acceptance by the Authority Having Jurisdiction. If air testing is required, DO NOT exceed 40 psi (2.8 bar) air pressure.

Trim Note: (Refer also to System Data and/or Trim Chart.)

Discharge piping from the auxiliary drain valve (C.1), the flow test valve (C.4), and all system drains should be kept separate. DO NOT connect the outlet of the drip check (C.2) to any other drain.

7. The priming line must be connected upstream of the system water supply main control valve (E.1).
8. After the deluge valve is set, operation of the deluge valve requires the release of priming water from the priming chamber. For Viking TRIMPAC® the release of the priming water from the priming chamber will be automatically controlled by the electric release system that is installed in the hazard area and is wired to a listed release control panel (G.1). Upon activation of the automatic electric release system, the listed release control panel will power the normally closed solenoid valve (B.12) in the Viking TRIMPAC® open, which will then relieve priming water pressure from the priming chamber.

CAUTION

Operation of Viking flow control valve by pressurizing the priming chamber with air pressure or any other pressurized gas is not recommended or approved.

9. Placing the System in Service: (Refer to Figures 3 - 10.)
 - a. Verify:
 - i. The system Main Water Supply Control Valve (E.1) is closed and that the TRIMPAC® Model B-3 & B-3B and required drain package is installed according to Viking Trim Charts and schematic drawings for the system used.
 - ii. The system has been properly drained.
 - iii. Auxiliary Drain (C.1) is open.
 - iv. The Emergency Release (B.1) is closed. **Note:** Emergency release (B.1) is closed when the handle is In-Line with the pipe. This allows the door to close when the valve is in the normal position.
 - v. The system water supply piping is pressurized up to the closed Main Water Supply Control Valve (E.1) and the priming line is pressurized up to the closed Priming Valve (B.2).
 - b. Open Priming Valve (B.2).
 - c. Set the electric release system. (Listed release control panel (G.1) must be in the reset position so the normally closed solenoid valve (B.12) is closed allowing the priming chamber to become pressurized, thereby setting the valve in the closed position.)
 - d. Re-establish air pressure on system piping if required. (Refer to NFPA 13 for air pressure requirements for Single Interlocked Preaction Systems.)
 - e. Open Flow Test Valve (C.4).
 - f. Partially open Main Water Supply Control Valve (E.1).
 - g. When full flow develops from the Flow Test Valve (C.4), close the Flow Test Valve. Verify that there is no flow from the open Auxiliary Drain Valve (C.1).
 - h. Close Auxiliary Drain (C.1).



TECHNICAL DATA

TRIMPAC® MODEL B-3 & B-3B SINGLE INTERLOCK PREACTION SYSTEM WITH ELECTRIC RELEASE

The Viking Corporation, 210 N Industrial Park Drive, Hastings MI 49058

Telephone: 269-945-9501 Technical Services: 877-384-5464 Fax: 269-818-1680 Email: techsvcs@vikingcorp.com

Visit the Viking website for the latest edition of this technical data page: www.vikinggroupinc.com

- i. Fully open and secure the Main Water Supply Control Valve (E.1).
- j. Verify that the Alarm Shut-off Valve (B.10) is open and all other valves are in their normal operating position.
- k. Depress the plunger of Drip Check (C.2). No water should flow from the Drip Check when the plunger is pushed.
- l. Check for and repair all leaks.
- m. On new installations, those systems that have been placed out of service or where new equipment has been installed, trip test the system to verify that all equipment functions properly. Refer to the deluge valve/flow control valve data page for Maintenance of the valve.

CAUTION

Performing a trip test results in operation of the flow control valve. Water will flow into the sprinkler piping. Take necessary precautions to prevent damage.

- n. Valve Removed from Service.

NOTE: WHEN A VALVE HAS BEEN REMOVED FROM SERVICE AND IS SUBJECT TO FREEZING OR WILL BE OUT OF SERVICE FOR AN EXTENDED PERIOD OF TIME, ALL WATER MUST BE REMOVED FROM THE PRIMING CHAMBER, TRIM PIPING, WATER SUPPLY PIPING, AND OTHER TRAPPED AREAS.

5. OPERATION (Refer to Figures 3 - 10.)

TRIMPAC® Model B-3 & B-3B incorporates an electric release module that controls the pressurization of the priming chamber of the deluge valve. Water is supplied to the deluge valve's priming chamber from an outlet upstream of the water supply control valve (E.1). Water flow to Point #1 of TRIMPAC® Model B-3 & B-3B, passes through the normally opened priming valve (B.2), Y strainer (B.3), 1/16" restricted orifice (B.4) and spring loaded check valve (B.5). Water is supplied to the inlet side of the normally closed solenoid valve (B.12) and to the priming side of the PORV (B.11). Priming water exits the TRIMPAC® Model B-3 & B-3B Model B-3 Point #2 of the TRIMPAC® Model B-3 & B-3B, passing to the priming chamber of the Deluge Valve (A.1), pressurizing the deluge valve closed. (Priming pressure can be identified at the priming pressure gauge view-port on the TRIMPAC® Model B-3 & B-3B.) Once priming pressure is present in the priming chamber of the deluge valve, the water supply control valve (E.1) can be opened. Once the water supply control valve is opened, water will pressurize the inlet chamber of the deluge valve, water will exit the inlet chamber of the deluge valve and enter Point #5 of the TRIMPAC® Model B-3 & B-3B. After water enters Point #5 of the TRIMPAC® Model B-3 & B-3B it will pressurize the water supply pressure gauge (B.9). Water pressure will now be available on the inlet of the normally closed alarm test valve (B.7). The valve and trim assembly is now in a normal operation mode.

In Fire Conditions:

Single Interlocked Preaction systems with an electric release require a compatible electric release device (or combination of compatible electric release devices) to activate in the hazard area which initiates a power sequence from the listed release control panel (G.1) to open the normally closed solenoid valve (B.12) in the TRIMPAC® Model B-3 & B-3B. The solenoid valve opens releasing the water pressure in the deluge valves priming chamber. Priming water is discharged from the outlet of the solenoid valve (B.12) to the drain cup (C.3). Once the priming water pressure is relieved in the priming chamber of the deluge valve, water supply pressure will pass from the inlet of the deluge valve to the outlet of the deluge valve to the sprinkler piping. During deluge valve operation, water is discharged through the valve drain package to Point #4 of the TRIMPAC® Model B-3 & B-3B. Water enters Point #4 of the TRIMPAC® Model B-3 & B-3B to activate the water flow alarms and pressurize the sensing side of the PORV (B.11). Once the sensing side of the PORV (B.11) is pressurized, priming water will be vented from the drain end of the PORV (B.11) through Point #3 of TRIMPAC® Model B-3 & B-3B to the drain package (drain cup) (C.3).

To return the system to "Normal" conditions, drain the system piping and replace any sprinklers that may have operated. Replace any detectors which have been damaged. Re-establish system air pressure by following the steps in section 4. INSTALLATION, Step 9 Placing the System in Service.

6. INSPECTIONS, TESTS AND MAINTENANCE

It is imperative that the system be inspected and tested on a regular basis. The frequency of the inspections may vary due to contaminated water supplies, corrosive water supplies, or corrosive atmospheres. Also, the alarm devices, detection systems, or other connected trim may require a more frequent schedule. For minimum maintenance and inspection requirements, refer to NFPA 25. In addition, the Authority Having Jurisdiction may have additional maintenance, testing, and inspection requirements that must be followed. Refer to the specific Viking deluge valve data page for periodic testing.

Maintenance:

TRIMPAC® Model B-3 & B-3B should be inspected, tested, and maintained in accordance with the latest edition of NFPA 25, The Standard for Inspection, Testing, and Maintenance of water based fire protection systems, and in accordance with the Authority Having Jurisdiction.



TECHNICAL DATA

TRIMPAC® MODEL B-3 & B-3B SINGLE INTERLOCK PREACTION SYSTEM WITH ELECTRIC RELEASE

The Viking Corporation, 210 N Industrial Park Drive, Hastings MI 49058

Telephone: 269-945-9501 Technical Services: 877-384-5464 Fax: 269-818-1680 Email: techsvcs@vikingcorp.com

Visit the Viking website for the latest edition of this technical data page: www.vikinggroupinc.com

NOTICE

The owner is responsible for maintaining the fire protection system and devices in proper operating condition. The flow control valve must be kept from freezing conditions and physical damage that could impair its operation. Contact the valve manufacturer or authorized representative when performance difficulty occurs and field adjustment is needed.

WARNING

Any system maintenance that involves placing a control valve or detection system out of service may eliminate the fire protection capabilities of that system. Prior to proceeding, notify all Authorities Having Jurisdiction. Consideration should be given to employment of a fire patrol in the affected areas.

After Each Operation:

1. Sprinkler systems that have been subjected to a fire must be returned to service as soon as possible. The entire system must be inspected for damage, and repaired or replaced as necessary.
2. Deluge valves and TRIMPAC® Model B-3 & B-3B that have been subjected to brackish water, salt water, foam, foam/water solution, or any other corrosive water supply should be flushed with good quality fresh water before being returned to service. Refer to specific deluge valve for maintenance schedule.

7. AVAILABILITY

The Viking TRIMPAC® Model B-3 & B-3B is available through a network of domestic and international distributors. See the Viking Corp. Web site for closest distributor or contact The Viking Corporation.

8. GUARANTEE

For details of warranty, refer to Viking's current list price schedule or contact Viking directly.

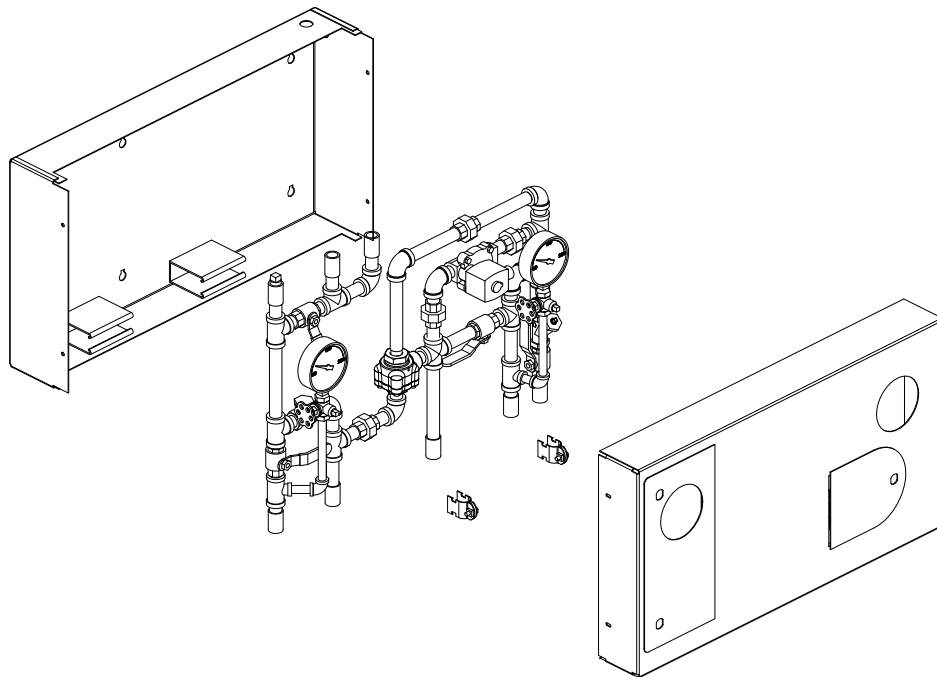

Figure 1 - Isometric View



TECHNICAL DATA

TRIMPAC® MODEL B-3 & B-3B SINGLE INTERLOCK PREACTION SYSTEM WITH ELECTRIC RELEASE

The Viking Corporation, 210 N Industrial Park Drive, Hastings MI 49058
 Telephone: 269-945-9501 Technical Services: 877-384-5464 Fax: 269-818-1680 Email: techsvcs@vikingcorp.com
 Visit the Viking website for the latest edition of this technical data page: www.vikinggroupinc.com

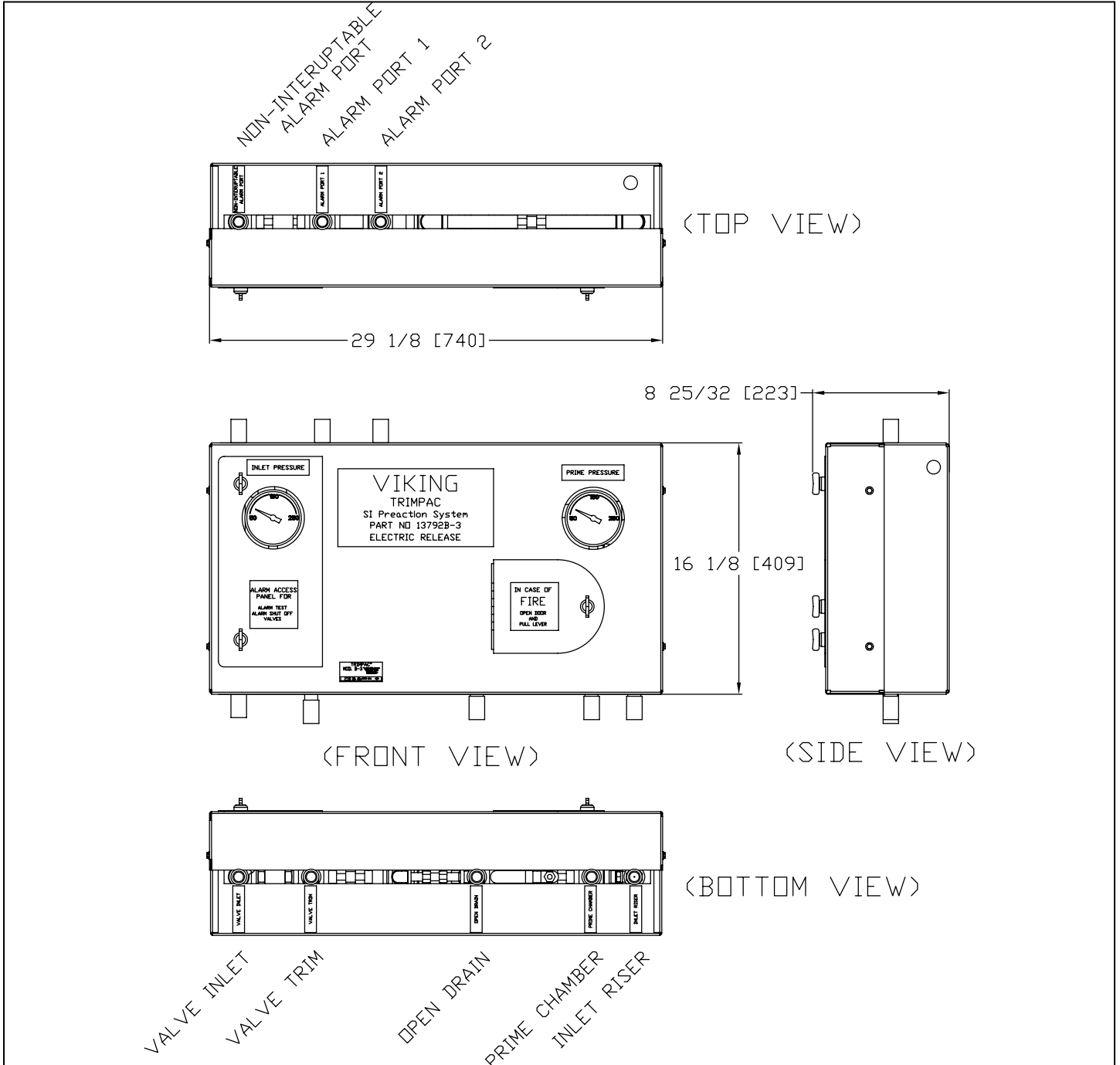

Figure 2 - Trimpac® Model B-3 Dimensions



TECHNICAL DATA

TRIMPAC® MODEL B-3 & B-3B SINGLE INTERLOCK PREACTION SYSTEM WITH ELECTRIC RELEASE

The Viking Corporation, 210 N Industrial Park Drive, Hastings MI 49058
 Telephone: 269-945-9501 Technical Services: 877-384-5464 Fax: 269-818-1680 Email: techsvcs@vikingcorp.com
 Visit the Viking website for the latest edition of this technical data page: www.vikinggroupinc.com

Ordering Information

Component	Description	Part Numbers	Corresponding Data Pages										
System Valve													
A	A.1 Deluge Valve	Various	F_040104, F_110802, F_040204, F_110902										
B	Trimpac	13792B-3	--										
		13792B-3B (Brass available by special order only)											
		28199B-3*											
		28199B-3B*											
*Note: Monitored solenoid option: Each of the above configurations can be ordered with a monitored or non-monitored release solenoid. The monitored solenoid is a new option, which offers an NFPA 13 solenoid monitoring-compliant solution.													
B.1 - B.12	Trimpac Components	Refer to Figure 10.											
Trimpac Drain Package													
C	C.1 Auxiliary Drain Valve (NC)	<table border="0"> <tr> <td style="text-align: center;">Galv.</td> <td style="text-align: center;">Brass</td> </tr> <tr> <td>1-1/2" - 11894-1 or 11894-5</td> <td></td> </tr> <tr> <td>2" - 11894-2 or 11894-6</td> <td></td> </tr> <tr> <td>2-1/2" & 3" - 11894-3 or 11894-7</td> <td></td> </tr> <tr> <td>4", 6", & 8" - 11894-4 or 11894-8</td> <td></td> </tr> </table>	Galv.	Brass	1-1/2" - 11894-1 or 11894-5		2" - 11894-2 or 11894-6		2-1/2" & 3" - 11894-3 or 11894-7		4", 6", & 8" - 11894-4 or 11894-8		--
	Galv.		Brass										
	1-1/2" - 11894-1 or 11894-5												
	2" - 11894-2 or 11894-6												
2-1/2" & 3" - 11894-3 or 11894-7													
4", 6", & 8" - 11894-4 or 11894-8													
C.2 Drip Check Valve													
C.3 Drain Cup													
C.4 Flow Test Valve (NC)													
Water Flow Alarm Equipment													
D	D.1 Alarm Pressure Switch	PS101A	-										
	D.2 Water Motor Alarm (F-2)	07862	F_082789										
	D.3 Strainer	01489A	--										
	D.4 Electric Alarm Bell	-	--										
Riser													
E	E.1 Water Supply Control Valve	-	--										
Check Valve													
F	F.1 1-1/2" & 2" - L-1 or M-1 Check Valve 3" - 8" - Easy Riser Check Valve	Various	--										
	F.2 Check Valve Trim	Various											
Release System													
G	G.1 VFR-500 Multi-Hazard Release Control Panel	26107	F_081022										
	G.2 Electrical Detection System (Heat Detector Shown for Clarity)	Various	--										

Table 1 - Trimpac System Components

Refer to Figures 3 through 10 for component identification.





TECHNICAL DATA

TRIMPAC® MODEL B-3 & B-3B SINGLE INTERLOCK PREACTION SYSTEM WITH ELECTRIC RELEASE

The Viking Corporation, 210 N Industrial Park Drive, Hastings MI 49058
 Telephone: 269-945-9501 Technical Services: 877-384-5464 Fax: 269-818-1680 Email: techsvcs@vikingcorp.com
 Visit the Viking website for the latest edition of this technical data page: www.vikinggroupinc.com

Legend for Figures 3 - 8

- Dotted lines indicate electrical system wiring required but not listed in "System Components" Table. For additional wiring requirements refer to technical data for components used.
- Dashed lines indicate pipe required but not included with TRIMPAC trim packages. Minimum 1/2" nominal piping recommended.
-  Smaller diameter hoses are the (4) included flexible braided stainless steel hoses. Also available as a kit (P/N) 12072
-  Larger diameter hose is the included PVC Drain Hose. Also available separately (P/N 12071).
- ** 1/2" (15 mm) NPT for non-interruptible Alarm Pressure Switch (Optional)

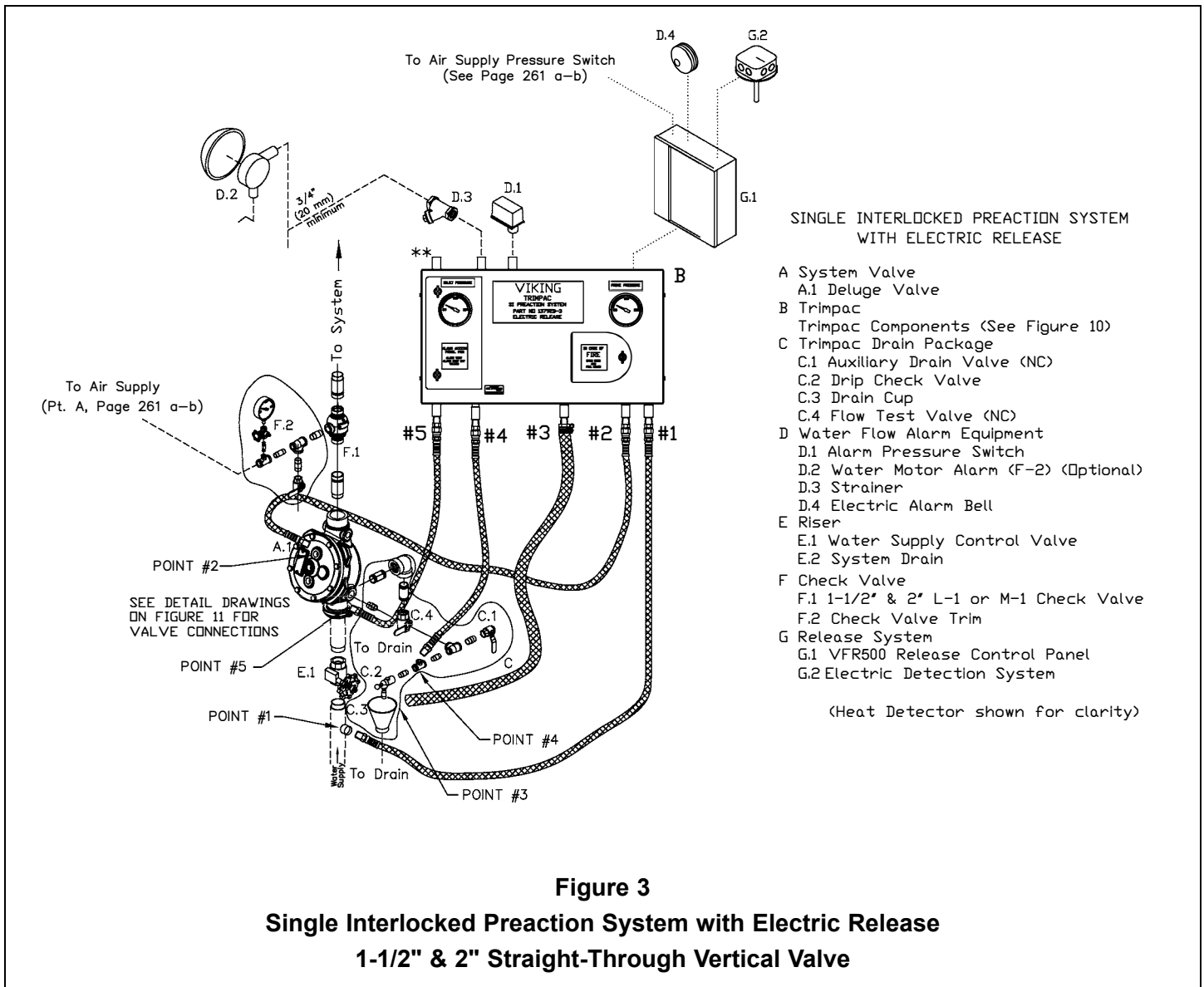



TECHNICAL DATA

TRIMPAC® MODEL B-3 & B-3B SINGLE INTERLOCK PREACTION SYSTEM WITH ELECTRIC RELEASE

The Viking Corporation, 210 N Industrial Park Drive, Hastings MI 49058
 Telephone: 269-945-9501 Technical Services: 877-384-5464 Fax: 269-818-1680 Email: techsvcs@vikingcorp.com
 Visit the Viking website for the latest edition of this technical data page: www.vikinggroupinc.com

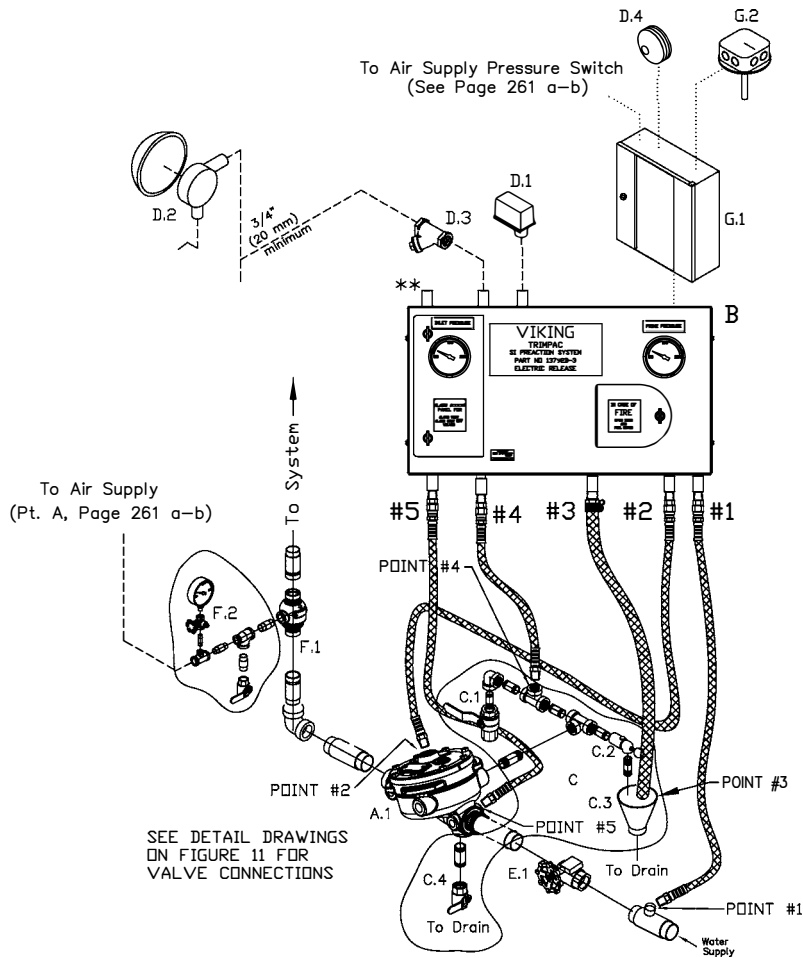

SINGLE INTERLOCKED PREACTION SYSTEM WITH ELECTRIC RELEASE

- A System Valve
 - A.1 Deluge Valve
- B Trimpac
- C Trimpac Components (See Figure 10)
 - C.1 Auxiliary Drain Valve (NC)
 - C.2 Drip Check Valve
 - C.3 Drain Cup
 - C.4 Flow Test Valve (NC)
- D Water Flow Alarm Equipment
 - D.1 Alarm Pressure Switch
 - D.2 Water Motor Alarm (F-2) (Optional)
 - D.3 Strainer
 - D.4 Electric Alarm Bell
- E Riser
 - E.1 Water Supply Control Valve
 - E.2 System Drain
- F Check Valve
 - F.1 1-1/2" & 2" L-1 or M-1 Check Valve
 - F.2 Check Valve Trim
- G Release System
 - G.1 VFR500 Release Control Panel
 - G.2 Electric Detection System

(Heat Detector shown for clarity)

Figure 6
Single Interlocked Preaction System with Electric Release
1-1/2" & 2" Straight-Through Horizontal Valve



TECHNICAL DATA

TRIMPAC® MODEL B-3 & B-3B SINGLE INTERLOCK PREACTION SYSTEM WITH ELECTRIC RELEASE

The Viking Corporation, 210 N Industrial Park Drive, Hastings MI 49058
 Telephone: 269-945-9501 Technical Services: 877-384-5464 Fax: 269-818-1680 Email: techsvcs@vikingcorp.com
 Visit the Viking website for the latest edition of this technical data page: www.vikinggroupinc.com

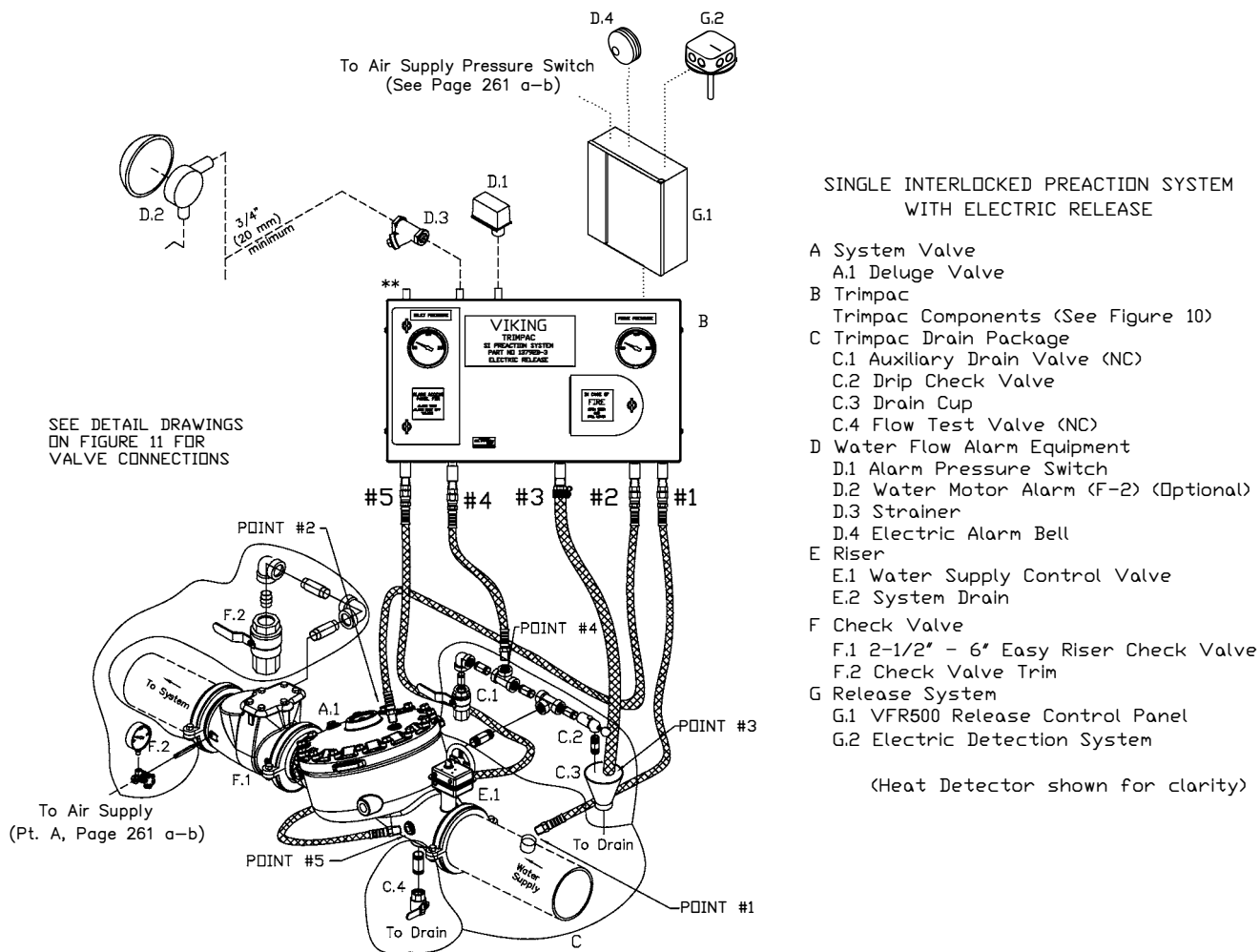

Figure 7
Single Interlocked Preaction System with Electric Release
2-1/2" - 6" Straight-Through Horizontal Valve



TECHNICAL DATA

TRIMPAC® MODEL B-3 & B-3B SINGLE INTERLOCK PREACTION SYSTEM WITH ELECTRIC RELEASE

The Viking Corporation, 210 N Industrial Park Drive, Hastings MI 49058
 Telephone: 269-945-9501 Technical Services: 877-384-5464 Fax: 269-818-1680 Email: techsvcs@vikingcorp.com
 Visit the Viking website for the latest edition of this technical data page: www.vikinggroupinc.com

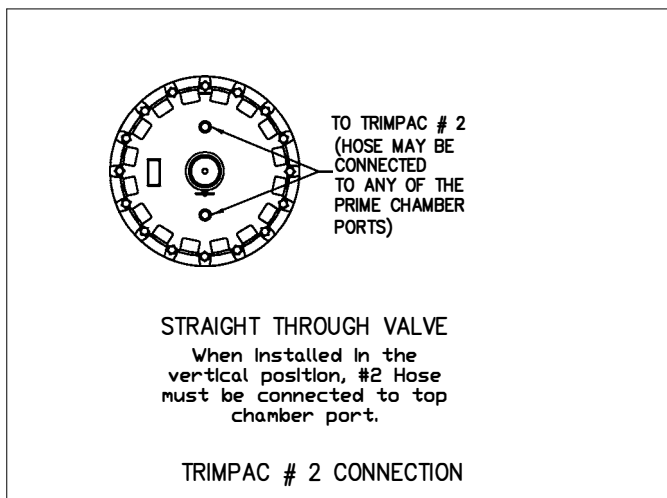
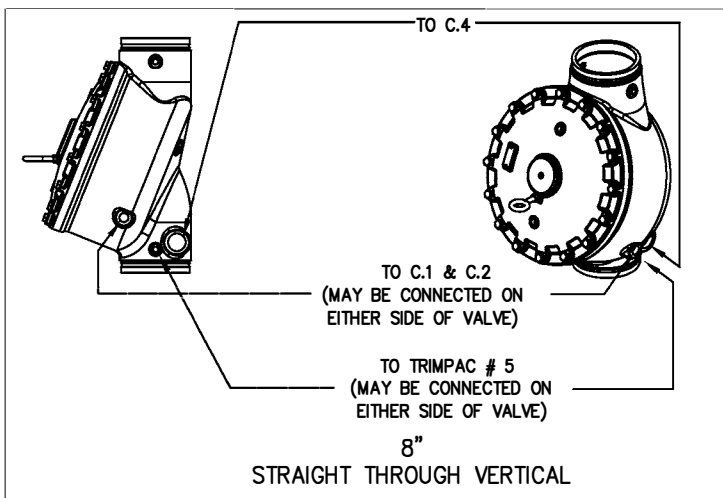
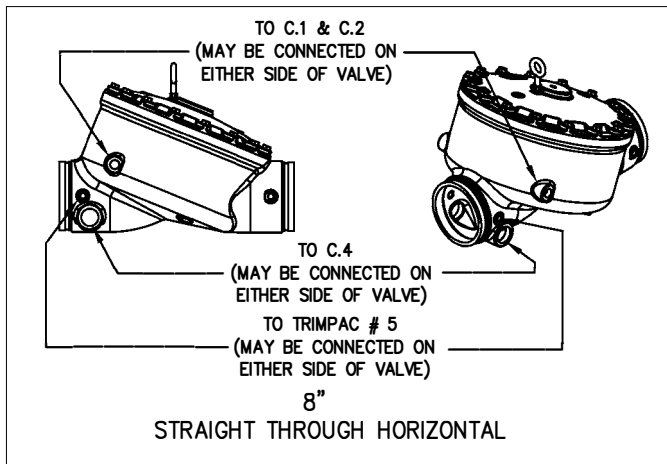
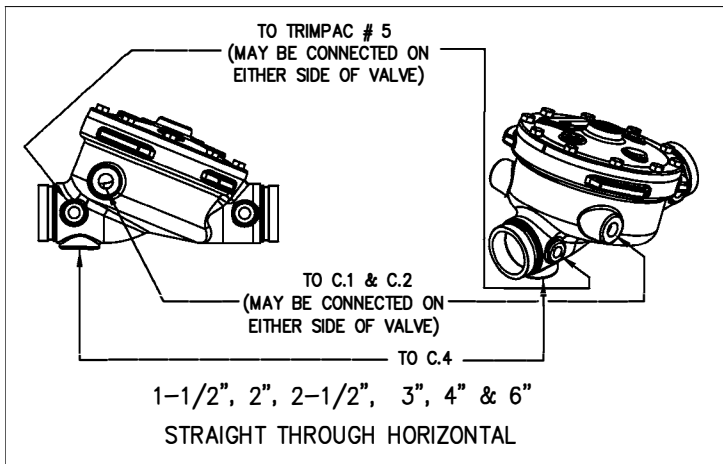
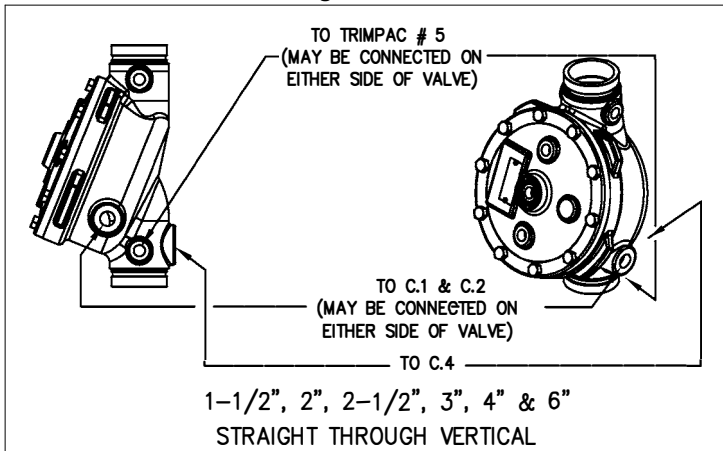

Figure 9 - Valve Connections



TECHNICAL DATA

TRIMPAC® MODEL B-3 & B-3B SINGLE INTERLOCK PREACTION SYSTEM WITH ELECTRIC RELEASE

The Viking Corporation, 210 N Industrial Park Drive, Hastings MI 49058
 Telephone: 269-945-9501 Technical Services: 877-384-5464 Fax: 269-818-1680 Email: techsvcs@vikingcorp.com
 Visit the Viking website for the latest edition of this technical data page: www.vikinggroupinc.com

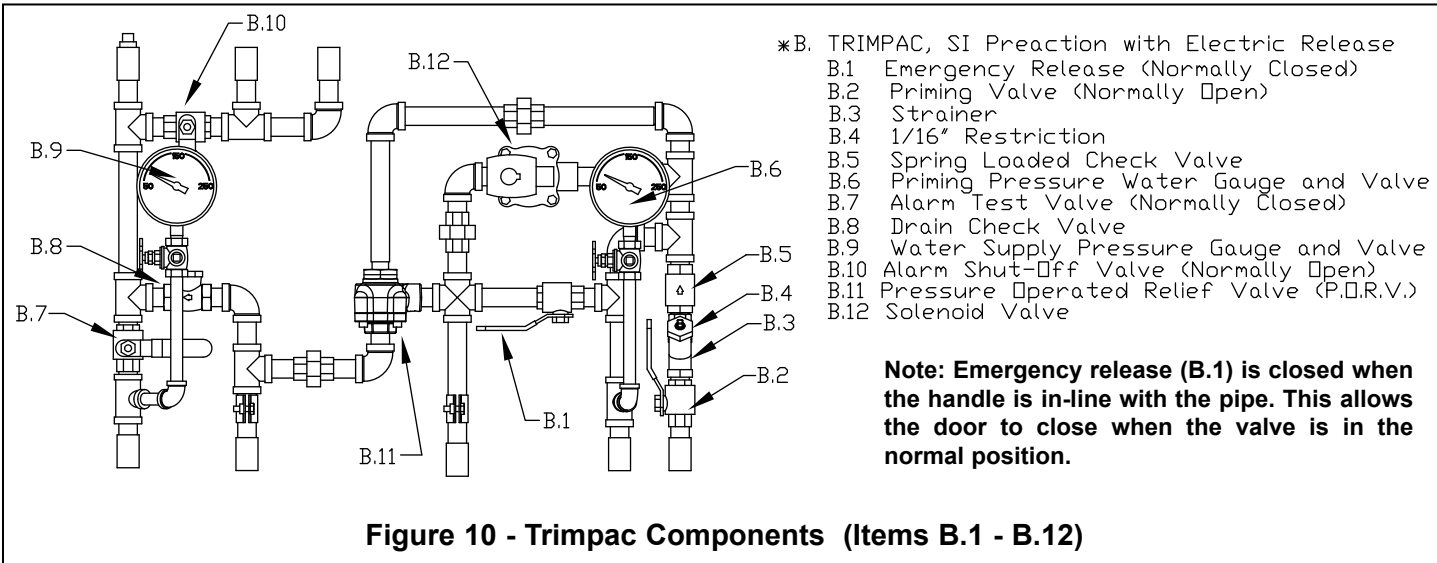
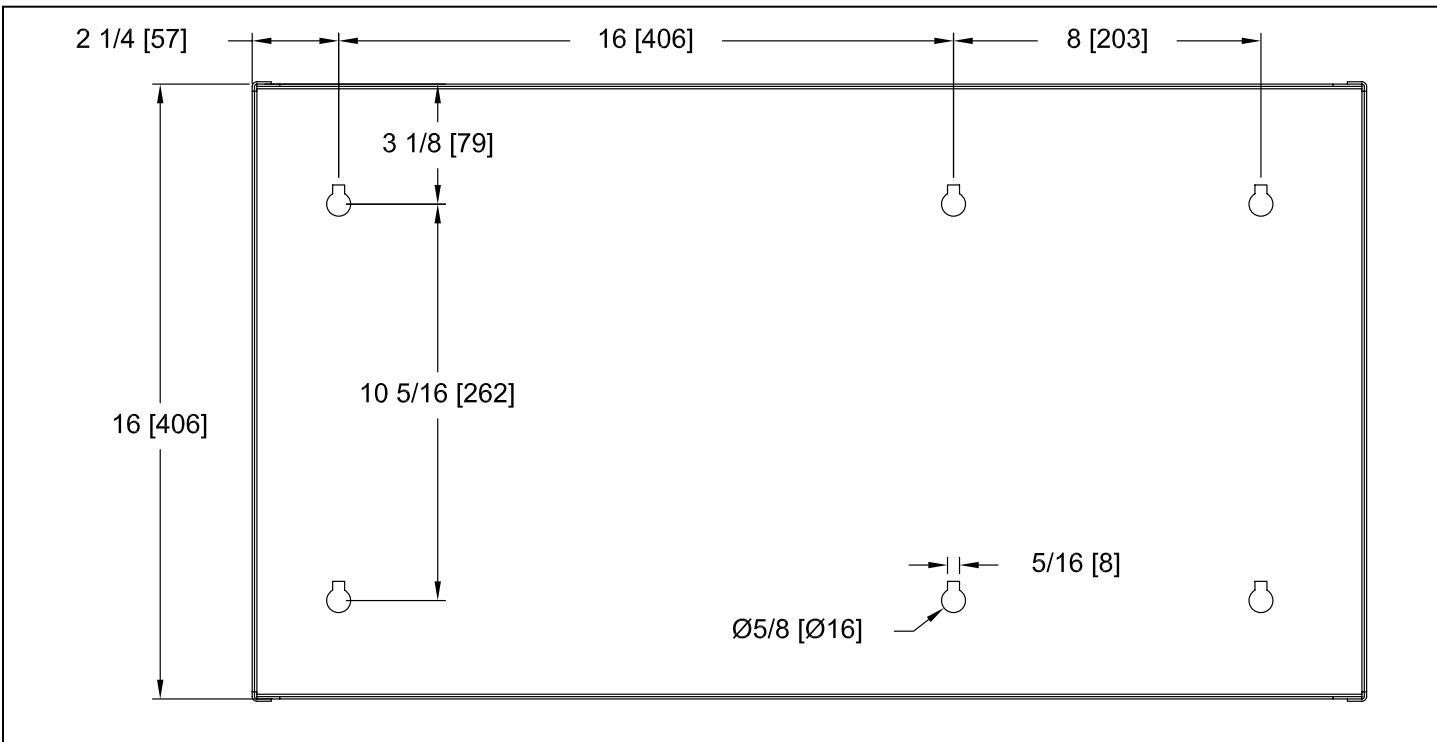

Figure 10 - Trimpac Components (Items B.1 - B.12)



Wall Mounting Notes:

1. Mounting Fasteners are supplied by the contractor.
2. Recommended Fasteners - Minimum 1/4" X 1-1/2 Lg. Hex Head lag screws with washers.
3. When installing into concrete, drywall or metal, use typical grommet.
4. Approximate Weight of TRIMPAC® Model B-3 & B-3B and Flexible Hoses: 34 lbs. (15.4 kg)

Figure 11 - Installation Dimensions



TECHNICAL DATA

TRIMPAC® MODEL B-3 & B-3B SINGLE INTERLOCK PREACTION SYSTEM WITH ELECTRIC RELEASE

The Viking Corporation, 210 N Industrial Park Drive, Hastings MI 49058
 Telephone: 269-945-9501 Technical Services: 877-384-5464 Fax: 269-818-1680 Email: techsvcs@vikingcorp.com
 Visit the Viking website for the latest edition of this technical data page: www.vikinggroupinc.com

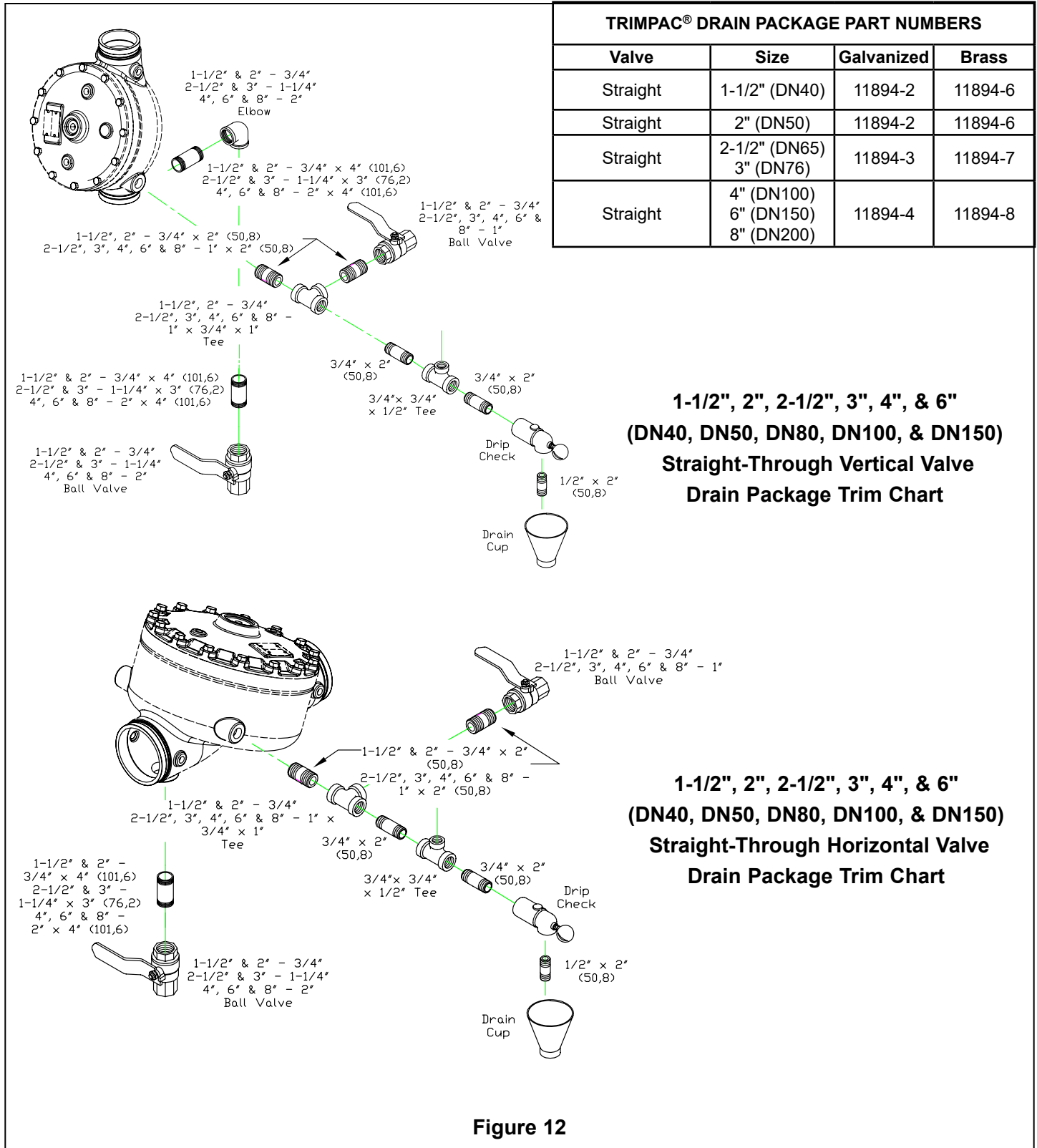

Figure 12



TECHNICAL DATA

TRIMPAC® MODEL B-3 & B-3B SINGLE INTERLOCK PREACTION SYSTEM WITH ELECTRIC RELEASE

The Viking Corporation, 210 N Industrial Park Drive, Hastings MI 49058
 Telephone: 269-945-9501 Technical Services: 877-384-5464 Fax: 269-818-1680 Email: techsvcs@vikingcorp.com
 Visit the Viking website for the latest edition of this technical data page: www.vikinggroupinc.com

TRIMPAC® DRAIN PACKAGE PART NUMBERS

Valve	Size	Galvanized	Brass
Straight	8" (DN200)	11894-4	11894-8

8" (DN200) Straight-Through Vertical Valve Drain Package Trim Chart

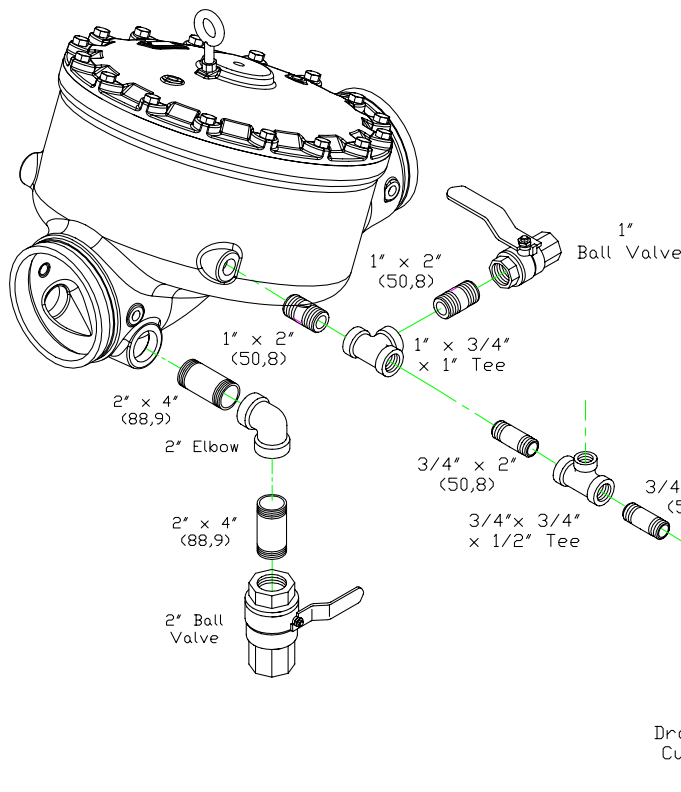

8" (DN200) Straight-Through Horizontal Valve Drain Package Trim Chart

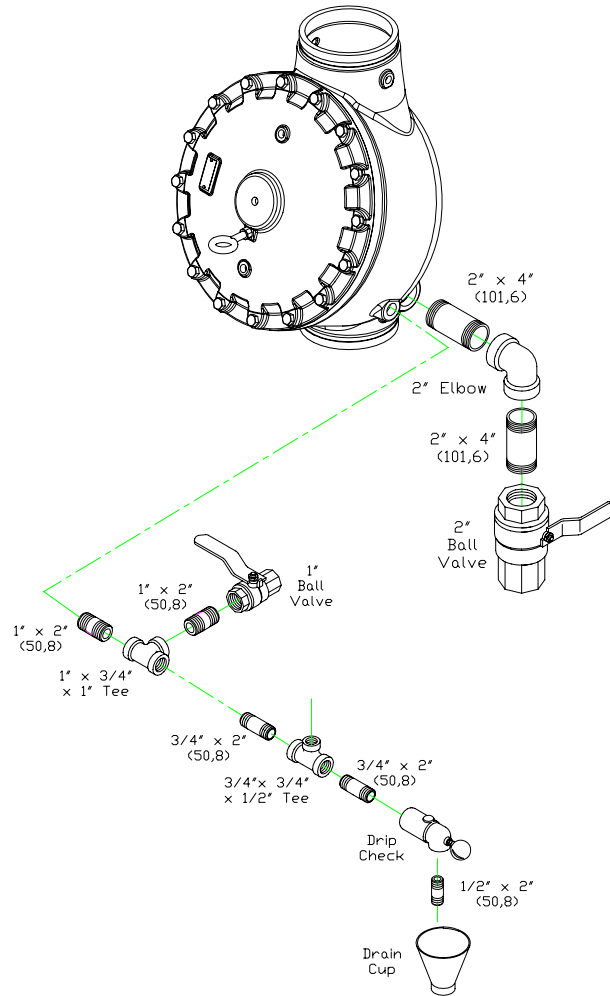

Figure 13