



TECHNICAL DATA

TRIMPAC® MODEL E-1 & E-1B FIRECYCLE® III MULTI-CYCLE SI & DI PREACTION

The Viking Corporation, 210 N Industrial Park Drive, Hastings MI 49058

Telephone: 269-945-9501 Technical Services: 877-384-5464 Fax: 269-818-1680 Email: techsvcs@vikingcorp.com

Visit the Viking website for the latest edition of this technical data page www.vikinggroupinc.com

1. DESCRIPTION

TRIMPAC® Model E-1 & E-1B is a factory assembled trim package for a Firecycle® III or Firecycle® III-OH Multi-Cycle Preaction System in a metal enclosure. The standard trim normally required on a flow control valve has been moved to a single cabinet. TRIMPAC® Model E-1 & E-1B provides access doors for the emergency release (B.1) and alarm test valve (B.7) for manual operation of these trim valves. TRIMPAC® Model E-1 & E-1B is equipped with priming water pressure and water supply gauge view-ports for easy monitoring of water pressures, and with a monitored solenoid (NC) or a non-monitored solenoid (NO). TRIMPAC® Model E-1 & E-1B eliminates the installation of alarm trim piping and release trim piping at the flow control valve. The enclosure protects trim valves from inadvertent operation. The included stainless steel hoses (or field provided hard piping) from the valve body to the enclosure assembly allows the assembly to be installed remote of the sprinkler system riser. TRIMPAC® Model E-1 & E-1B can be utilized for systems regardless of valve size. A valve drain package is required for the flow control valve and is ordered based on the flow control valve size. See Figures 12 and 13 for drain trim charts.

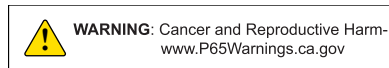

2. LISTINGS AND APPROVALS

cULus Listed: VLTR & VLTR7

3. TECHNICAL DATA

Specifications:

Rated Water Working Pressure: 250 psi (17.2 bar)

Gauges: 0-300 PSI (0-20.7 bar)

Weight: 34 lbs. (15.4 kg.)

Dimensions: 16-1/8" (409 mm) high x 29-1/8" (748 mm) wide x 8-25/32" (223 mm) deep

Material Standards:

Enclosure: 16 gauge steel, painted red: Epoxy Powder Coat

Gauges: Brass 1/4" NPT, Plastic Body

Pneumatic Actuator: Brass Body 1/2" (1.27 cm) connections

Solenoid Valves (1 NC, 1 NO):

- Monitored Solenoid (NC): Brass body, 24 VDC, 5-300 PSI (0.34-20.7 bar), NEMA Rated 2, 3, 3S, 4, 4X, 9.0 Watts
- Non-Monitored Solenoids (NO): Brass Body 1/2" (1.27 cm), 24 Volt DC, 250 psi (17.2 bar) NEMA Rated 1, 2, 3, 3S, 4 or 4X, 9 Watts

PORV: Brass Body, 250 PSI (17.2 bar), 1/2" NPT inlet, 1/2" NTP drain, 1/2" NPT sensing side

Ball valves: 1/2" NPT female ends

Strainer: Brass Body, 1/2" NPT inlet and outlet, 50 mesh stainless steel screen

Restricted orifice: Brass Body, 1/2" NPT male inlet and outlet, 0.125" orifice

Spring Loaded Check Valve: Brass Body, 1/2" NPT female inlet and outlet

Drain Check Valve: Brass Body, 1/2" NPT female inlet and outlet, EPDM clapper rubber

Hoses (4): Flexible braided stainless steel hoses with steel fittings and connectors, PTFE lined

Drain Hose (1): PVC Hose 60" long with brass hose connector x 1/2" NPT

Trim Piping: 1/2" Galvanized or 1/2" Brass

Fittings: 1/2" Galvanized

Ordering Information: Refer to Table 1.

Accessories:

1. Vertical Mounting Plate Kit - Part No. 11900
2. Horizontal Mounting Plate Kit - Part No. 11901
3. Hose Assembly Kit (Includes (4) Stainless Steel Hoses and (1) PVC Drain Hose) - Part No. 12072 (included with Part Nos. 13801E-1 and 13801E-1B)
4. Individual 5'-0" Stainless Steel & PTFE Hose: Part No. 16558 (4 required)
5. Individual PVC Hose: Part No. 12071 (1 required)



TECHNICAL DATA

TRIMPAC® MODEL E-1 & E-1B FIRECYCLE® III MULTI-CYCLE SI & DI PREACTION

The Viking Corporation, 210 N Industrial Park Drive, Hastings MI 49058

Telephone: 269-945-9501 Technical Services: 877-384-5464 Fax: 269-818-1680 Email: techsvcs@vikingcorp.com

Visit the Viking website for the latest edition of this technical data page www.vikinggroupinc.com

4. INSTALLATION (Refer to Figures 3 - 10 for identification of trim components. Refer to Figure 11 for wall-mounting.)

1. TRIMPAC® Model E-1 & E-1B Trim Assemblies may be installed with the straight-through style Model J Flow Control Valves, sizes 1-1/2", 2", 3" 4", 6", and 8".
2. **TRIMPAC® Model E-1 & E-1B trim assembly and valve must be installed in an area not subject to freezing.**
3. **TRIMPAC® Model E-1 & E-1B trim assembly must be installed to facilitate drainage.**
4. **TRIMPAC® Model E-1 & E-1B trim assembly must be installed above the elevation of the drip check valve (C.2).**
5. TRIMPAC® Model E-1 & E-1B Trim Assembly can be installed with the furnished hose package or 1/2" non-corrosive metallic piping. The maximum distance the TRIMPAC® Model E-1 & E-1B may be installed away from the flow control valve is 5'-0".
6. The flow control valve equipped with TRIMPAC® Model E-1 & E-1B must be installed in accordance with Viking Technical data. The required drain package must be installed in accordance with Figures 12 and 13.
 - a. Remove all plastic thread protectors from the openings of the flow control valve and the TRIMPAC® Model E-1 & E-1B trim assembly.
 - b. Apply a small amount of pipe-joint compound or tape to the external threads of all pipe connections required. Take care not to allow any compound, tape, or other foreign matter inside any of the nipples or openings of the valve or trim components.
 - c. Verify that all system components are rated for the water working pressure of the system.

Hydrostatic Test:

The Viking flow control valve is manufactured and listed for use at a maximum Water Working Pressure of 250 PSI (17.2 bar). The valve is factory tested at 500 psi (34.5 bar). The Viking flow control valve may be hydrostatically tested at 300 PSI (20.7 bar) and/or 50 PSI (3.5 bar) above the normal Water Working Pressure, for limited periods of time (2 hours) for the purpose of acceptance by the Authority Having Jurisdiction. If air testing is required, DO NOT exceed 40 psi (2.8 bar) air pressure.

Trim Note: (Refer also to System Data and/or Trim Chart.)

Discharge piping from the auxiliary drain valve (C.1), the flow test valve (C.4), and all system drains should be kept separate. DO NOT connect the outlet of the drip check (C.2) to any other drain.

7. The priming line must be connected upstream of the system water supply main control valve (B.1).
8. After the flow control valve is set, operation requires the release of priming water from the priming chamber. For TRIMPAC® Model E-1 & E-1B, the release of the priming water from the priming chamber will be automatically controlled by the electric release system that is installed in the hazard area. Upon activation of the automatic electric release system, the normally closed solenoid (B.14) will be opened in the TRIMPAC® Model E-1 & E-1B, which will then relieve priming water pressure from the priming chamber.

CAUTION

Operation of Viking flow control valve by pressurizing the priming chamber with air pressure or any other pressurized gas is not recommended or approved.

9. Placing the System in Service: (Refer to Figures 3 - 10.)

- a. Verify:
 - i. The system Main Water Supply Control Valve (D.1) is closed and that the TRIMPAC® Model E-1 & E-1B and required drain package is installed according to Viking Trim Charts and schematic drawings for the system used.
 - ii. The system has been properly drained.
 - iii. Auxiliary Drain (C.1) is open.
 - iv. The Emergency Release (B.1) is closed. **Note:** Emergency release (B.1) is closed when the handle is In-Line with the pipe. This allows the door to close when the valve is in the normal position.
 - v. The system water supply piping is pressurized up to the closed Main Water Supply Control Valve (D.1) and the priming line is pressurized up to the closed Priming Valve (B.2).
 - vi. Apply air pressure to 35 psi (2.4 bar) (55 psi (3.8 bar) for systems with greater than 175 psi (12 bar) water pressure) on system piping.
- b. Open Priming Valve (B.2).
- c. Set the release system. (Listed Firecycle® III or VFR-500 release control panel (F.1) must be in the reset position so the normally closed solenoid valve (B.14) is closed allowing the priming chamber to become pressurized, thereby setting the valve in the closed position.)
- d. Open Flow Test Valve (C.4)
- e. Partially open Main Water Supply Control Valve (D.1).
- f. When full flow develops from the Flow Test Valve (C.4), close the Flow Test Valve. Verify that there is no flow from the open Auxiliary Drain Valve (C.1).
- g. Close Auxiliary Drain (C.1).
- h. Fully open and secure the Main Water Supply Control Valve (D.1).
- i. Verify that the Alarm Shut-off Valve (B.10) is open and all other valves are in their normal operating position.
- j. Depress the plunger of Drip Check (C.2). No water should flow from the Drip Check when the plunger is pushed.



TECHNICAL DATA

TRIMPAC® MODEL E-1 & E-1B FIRECYCLE® III MULTI-CYCLE SI & DI PREACTION

The Viking Corporation, 210 N Industrial Park Drive, Hastings MI 49058

Telephone: 269-945-9501 Technical Services: 877-384-5464 Fax: 269-818-1680 Email: techsvcs@vikingcorp.com

Visit the Viking website for the latest edition of this technical data page www.vikinggroupinc.com

- k. Check for and repair all leaks.
- l. On new installations, those systems that have been placed out of service or where new equipment has been installed, trip test the system to verify that all equipment functions properly. Refer to the flow control valve data page for Maintenance of the valve.

⚠ CAUTION

Performing a trip test results in operation of the flow control valve. Water will flow into the sprinkler piping. Take necessary precautions to prevent damage.

- m. Valve Removed from Service.

NOTE: WHEN A VALVE HAS BEEN REMOVED FROM SERVICE AND IS SUBJECT TO FREEZING OR WILL BE OUT OF SERVICE FOR AN EXTENDED PERIOD OF TIME, ALL WATER MUST BE REMOVED FROM THE PRIMING CHAMBER, TRIM PIPING, WATER SUPPLY PIPING, AND OTHER TRAPPED AREAS.

5. OPERATION (Refer to Figures 3 - 10.)

System water supply pressure enters the priming chamber of the Flow Control Valve (A.1) through the 1/2" (13 mm) priming line, which includes a normally open priming valve (B.2), strainer (B.3), restricted orifice (B.4) and check valve (B.5). In the SET condition, water supply pressure is trapped in the priming chamber by check valve (B.5), normally closed Emergency Release (B.1), Pneumatic Actuator (B.12), and normally closed Release Solenoid Valve #1 (B.14). Water Supply pressure in the priming chamber holds the clapper of the Flow Control Valve (A.1) on the seat due to the differential design of the valve and spring pressure. The clapper separates the inlet chamber from the outlet chamber, keeping the outlet chamber and system piping dry.

In Fire Conditions:

When the Firecycle® III or Firecycle® III-OH detection system (F.2) operates, the Firecycle® III or VFR-500 Control Panel (F.1) activates the system alarm and energizes normally closed Release Solenoid Valve #1 (B.14) open and normally open Release Solenoid Valve #2 (B.16) closed. Pressure is released from the priming chamber faster than it is supplied through the restricted orifice (B.4). The Flow Control Valve (A.1) clapper opens to allow water to flow into the system piping and to alarm devices, causing Alarm Pressure Switch (B.13) to activate. Water entering the system operates and hydraulically latches the Pressure Operated Relief Valve (PORV) (B.11) open. Water will flow from any open sprinklers or nozzles. Water discharges until all Firecycle® Detectors have reset (cooled below their set point). After all detectors have reset, the Firecycle® III or VFR-500 Control Panel (F.1) activates the "Soak Timer", allowing the system to continue discharging water for a preset time period. When the "Soak Timer" has expired, the Firecycle® III or VFR-500 Control Panel (F.1) de-energizes normally closed Release Solenoid Valve #1 (B.14), allowing it to close. (The normally open Release Solenoid Valve #2 (B.16) remains energized closed until the Firecycle® III or VFR-500 Control Panel is manually reset, or both A.C. Power and battery backup have failed.) The Flow Control Valve (A.1) re-priming and closes, stopping the flow of water through the system piping.

Should a Firecycle® Detector go into alarm, the Firecycle® III or VFR-500 Control Panel (F.1) re-energizes the normally closed Release Solenoid Valve #1 (B.14) open, and the entire cycle repeats.

To return the system to "Normal" conditions, drain the system piping and replace any sprinklers that may have operated. Relieve the pressure on the Pressure Operated Relief Valve (PORV) (B.11) by draining the outlet chamber of the Flow Control Valve (A.1). Replace any Firecycle® Detectors that have been damaged and re-establish system air pressure. Press the "System Reset" button on the Firecycle® III or VFR-500 Control Panel (F.1) to clear all alarms.

6. INSPECTIONS, TESTS AND MAINTENANCE

It is imperative that the system be inspected and tested on a regular basis. The frequency of the inspections may vary due to contaminated water supplies, corrosive water supplies, or corrosive atmospheres. Also, the alarm devices, detection systems, or other connected trim may require a more frequent schedule. For minimum maintenance and inspection requirements, refer to NFPA 25. In addition, the Authority Having Jurisdiction may have additional maintenance, testing, and inspection requirements that must be followed. Refer to the specific Viking flow control valve data page for periodic testing.

Maintenance:

TRIMPAC® Model E-1 & E-1B should be inspected, tested, and maintained in accordance with the latest edition of NFPA 25, The Standard for Inspection, Testing, and Maintenance of water based fire protection systems, and in accordance with the Authority Having Jurisdiction.

NOTICE

The owner is responsible for maintaining the fire protection system and devices in proper operating condition. The flow control valve must be kept from freezing conditions and physical damage that could impair its operation. Contact the valve manufacturer or authorized representative when performance difficulty occurs and field adjustment is needed.



TECHNICAL DATA

TRIMPAC® MODEL E-1 & E-1B FIRECYCLE® III MULTI-CYCLE SI & DI PREACTION

The Viking Corporation, 210 N Industrial Park Drive, Hastings MI 49058

Telephone: 269-945-9501 Technical Services: 877-384-5464 Fax: 269-818-1680 Email: techsvcs@vikingcorp.com

Visit the Viking website for the latest edition of this technical data page www.vikinggroupinc.com

⚠ WARNING

Any system maintenance that involves placing a control valve or detection system out of service may eliminate the fire protection capabilities of that system. Prior to proceeding, notify all Authorities Having Jurisdiction. Consideration should be given to employment of a fire patrol in the affected areas.

After Each Operation:

1. Sprinkler systems that have been subjected to a fire must be returned to service as soon as possible. The entire system must be inspected for damage, and repaired or replaced as necessary.
2. Flow control valves and TRIMPAC® Model E-1 & E-1B that have been subjected to brackish water, salt water, foam, foam/water solution, or any other corrosive water supply should be flushed with good quality fresh water before being returned to service. Refer to specific flow control valve for maintenance schedule.

7. AVAILABILITY

The Viking TRIMPAC® Model E-1 & E-1B is available through a network of domestic and international distributors. See the Viking Corp. Web site for closest distributor or contact The Viking Corporation.

8. GUARANTEE

For details of warranty, refer to Viking's current list price schedule or contact Viking directly.

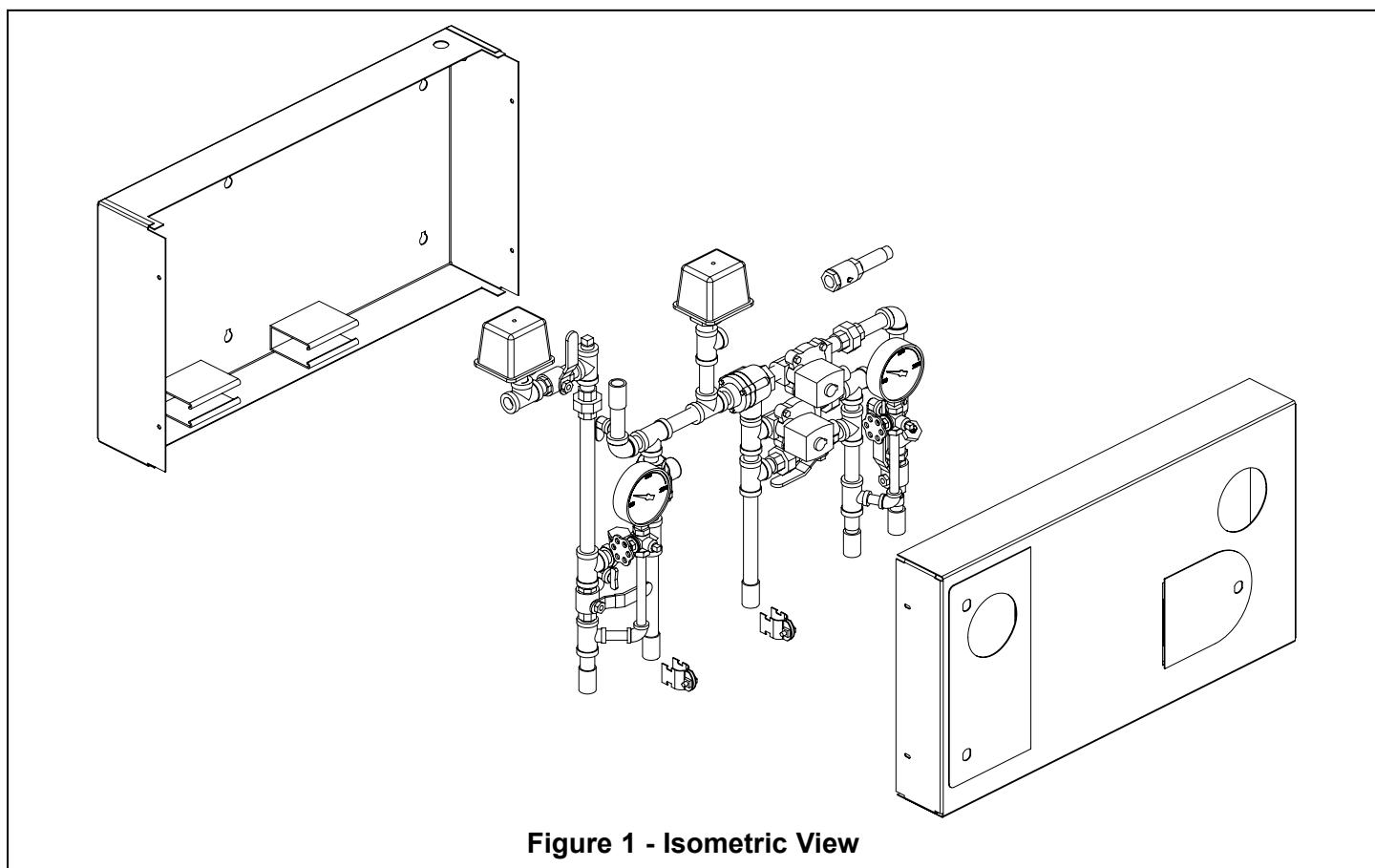

Figure 1 - Isometric View



TECHNICAL DATA

**TRIMPAC® MODEL E-1 & E-1B
FIRECYCLE® III MULTI-CYCLE
SI & DI PREACTION**

The Viking Corporation, 210 N Industrial Park Drive, Hastings MI 49058
 Telephone: 269-945-9501 Technical Services: 877-384-5464 Fax: 269-818-1680 Email: techsvcs@vikingcorp.com
 Visit the Viking website for the latest edition of this technical data page www.vikinggroupinc.com

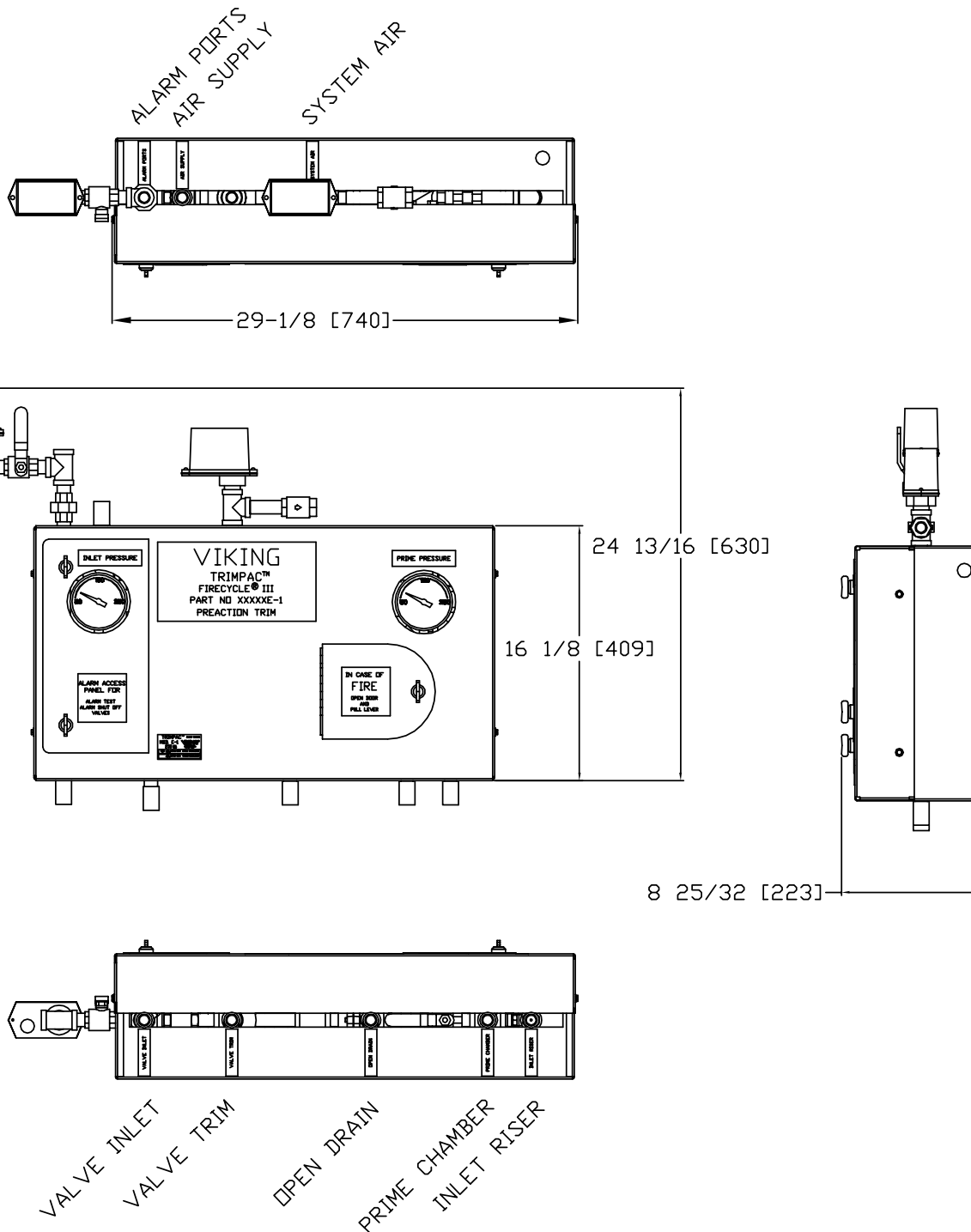

Figure 2 - TRIMPAC® Model E-1 Dimensions



TECHNICAL DATA

TRIMPAC® MODEL E-1 & E-1B FIRECYCLE® III MULTI-CYCLE SI & DI PREACTION

The Viking Corporation, 210 N Industrial Park Drive, Hastings MI 49058
 Telephone: 269-945-9501 Technical Services: 877-384-5464 Fax: 269-818-1680 Email: techsvcs@vikingcorp.com
 Visit the Viking website for the latest edition of this technical data page www.vikinggroupinc.com

Ordering Information

Component	Description	Part Numbers		Corresponding Data Pages		
System Valve						
A	A.1	Flow Control Valve	Various		F_040304, F_040402, F_040404, F_040502	
	TRIMPAC®		13801E-1	--		
13801E-1B (Brass available by special order only.)						
28155E-1*						
28155E-1B*						
*Note: Monitored solenoid option: Each of the above configurations can be ordered with a monitored or non-monitored release solenoid. The monitored solenoid is a new option, which offers an NFPA 13 solenoid monitoring-compliant solution.						
B.1 - B.17	TRIMPAC® Components	Refer to Figure 10.				
TRIMPAC® Drain Package						
C	C.1	Auxiliary Drain Valve (NC)	Galv. Brass 1-1/2" - 11894-1 or 11894-5 2" - 11894-2 or 11894-6 2-1/2" & 3" - 11894-3 or 11894-7 4", 6" & 8" - 11894-4 or 11894-8		--	
	C.2	Drip Check Valve				
	C.3	Drain Cup				
	C.4	Flow Test Valve (NC)				
Riser						
D	D.1	Water Supply Control Valve	Various		Refer to manufacturer's documentation**	
**For questions, contact Viking Tech Services.						
Check Valve						
E	E.1	M-2 Check Valve	22550		F_032405	
		1-1/2" & 2" - L-1 or K-1 Check Valve 3" - 8" - Easy Riser® Check Valve	Various		F_012202 F_011189	
	E.2	Check Valve Trim	Various			
Release System						
F	F.1	VFR-500 Multi-Hazard Release Control Panel	26107		F_081022	
	F.2	Firecycle® Detectors	Firecycle® III Model B	Various		F_071697
			Firecycle® OH Model C	Various		F_040902
	F.3	Detector Cables	FPL Cable	16 Gauge - 19749 18 Gauge - 19750		F_031915
Table 1 - TRIMPAC® System Components						
Refer to Figures 3 through 10 for Component Identification.						





TECHNICAL DATA

TRIMPAC® MODEL E-1 & E-1B FIRECYCLE® III MULTI-CYCLE SI & DI PREACTION

The Viking Corporation, 210 N Industrial Park Drive, Hastings MI 49058
 Telephone: 269-945-9501 Technical Services: 877-384-5464 Fax: 269-818-1680 Email: techsvcs@vikingcorp.com
 Visit the Viking website for the latest edition of this technical data page www.vikinggroupinc.com

Legend for Figures 3 - 8

- Dotted lines indicate electrical system wiring required but not listed in "System Components" Table. For additional wiring requirements refer to technical data for components used.
 - Dashed lines indicate pipe required but not included with TRIMPAC trim packages. Minimum 1/2" nominal piping recommended.
 -  Smaller diameter hoses are the (4) included flexible braided stainless steel hoses. Also available as a kit (P/N) 12072
 -  Larger diameter hose is the included PVC Drain Hose. Also available separately (P/N 12071).
- ** 1/2" (15 mm) NPT for non-interruptible Alarm Pressure Switch (Optional)

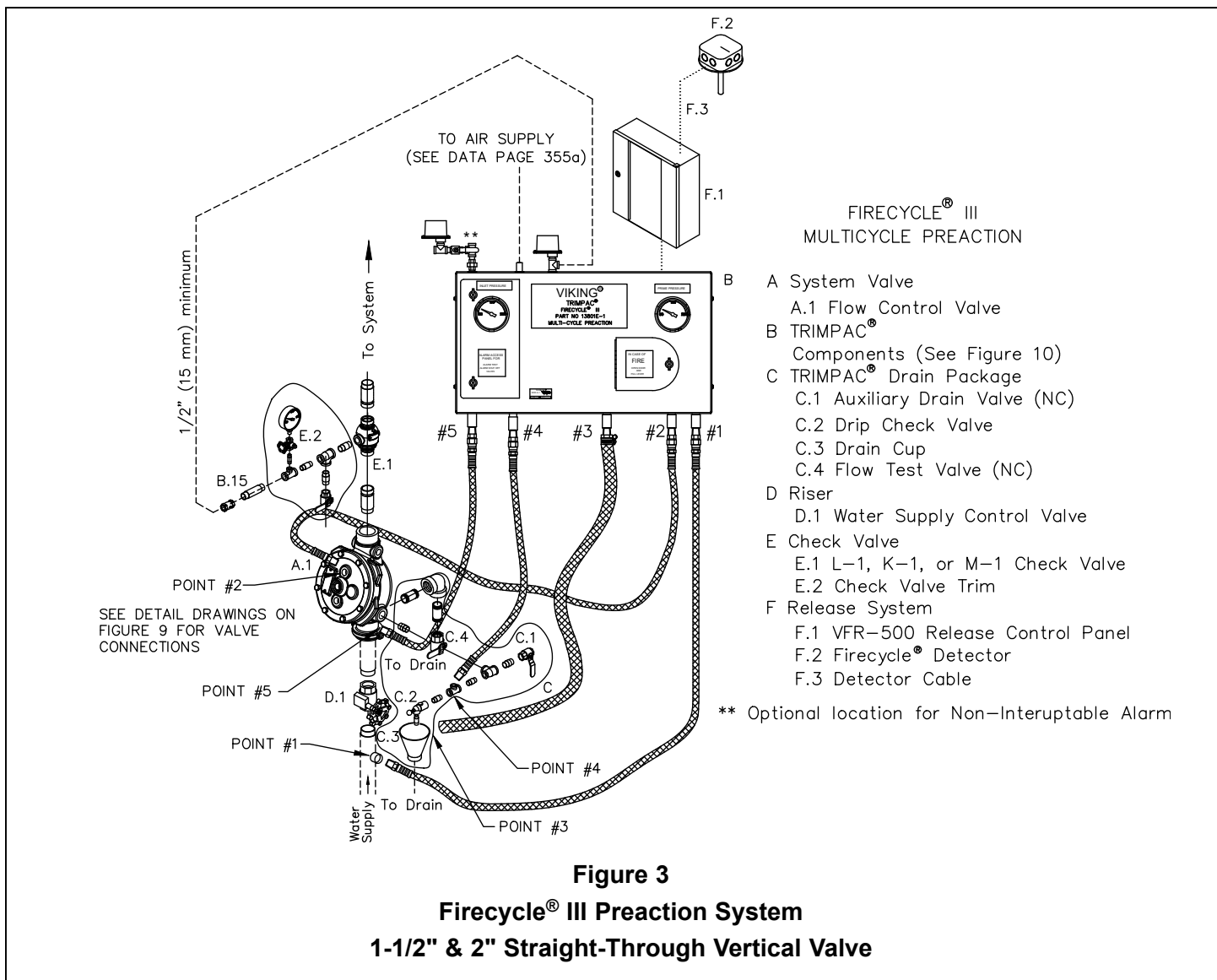



TECHNICAL DATA

TRIMPAC® MODEL E-1 & E-1B FIRECYCLE® III MULTI-CYCLE SI & DI PREACTION

The Viking Corporation, 210 N Industrial Park Drive, Hastings MI 49058
 Telephone: 269-945-9501 Technical Services: 877-384-5464 Fax: 269-818-1680 Email: techsvcs@vikingcorp.com
 Visit the Viking website for the latest edition of this technical data page www.vikinggroupinc.com

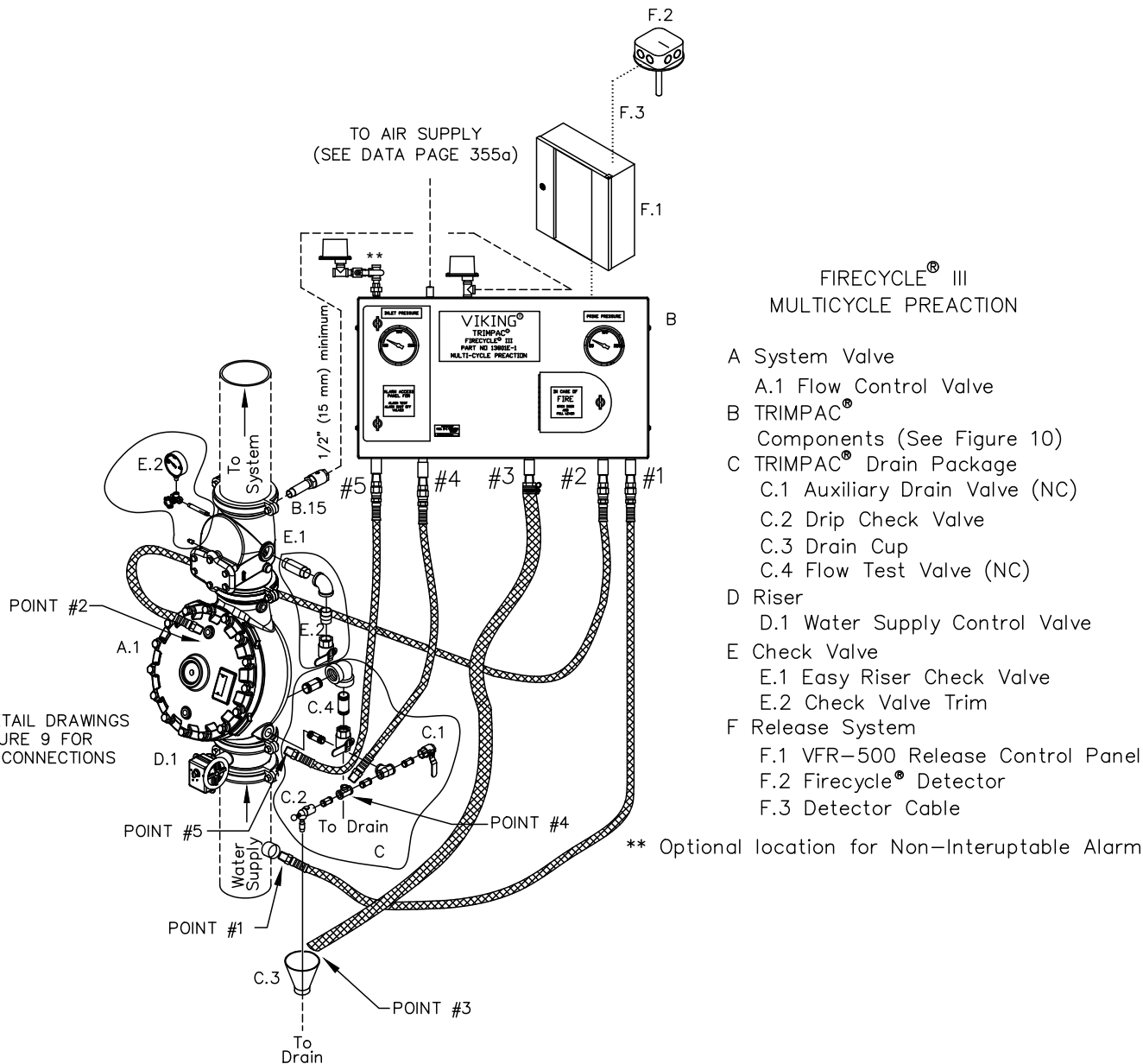

Figure 4
Firecycle® III Preaction System
2-1/2" - 6" Straight-Through Vertical Valve



TECHNICAL DATA

TRIMPAC® MODEL E-1 & E-1B FIRECYCLE® III MULTI-CYCLE SI & DI PREACTION

The Viking Corporation, 210 N Industrial Park Drive, Hastings MI 49058
 Telephone: 269-945-9501 Technical Services: 877-384-5464 Fax: 269-818-1680 Email: techsvcs@vikingcorp.com
 Visit the Viking website for the latest edition of this technical data page www.vikinggroupinc.com

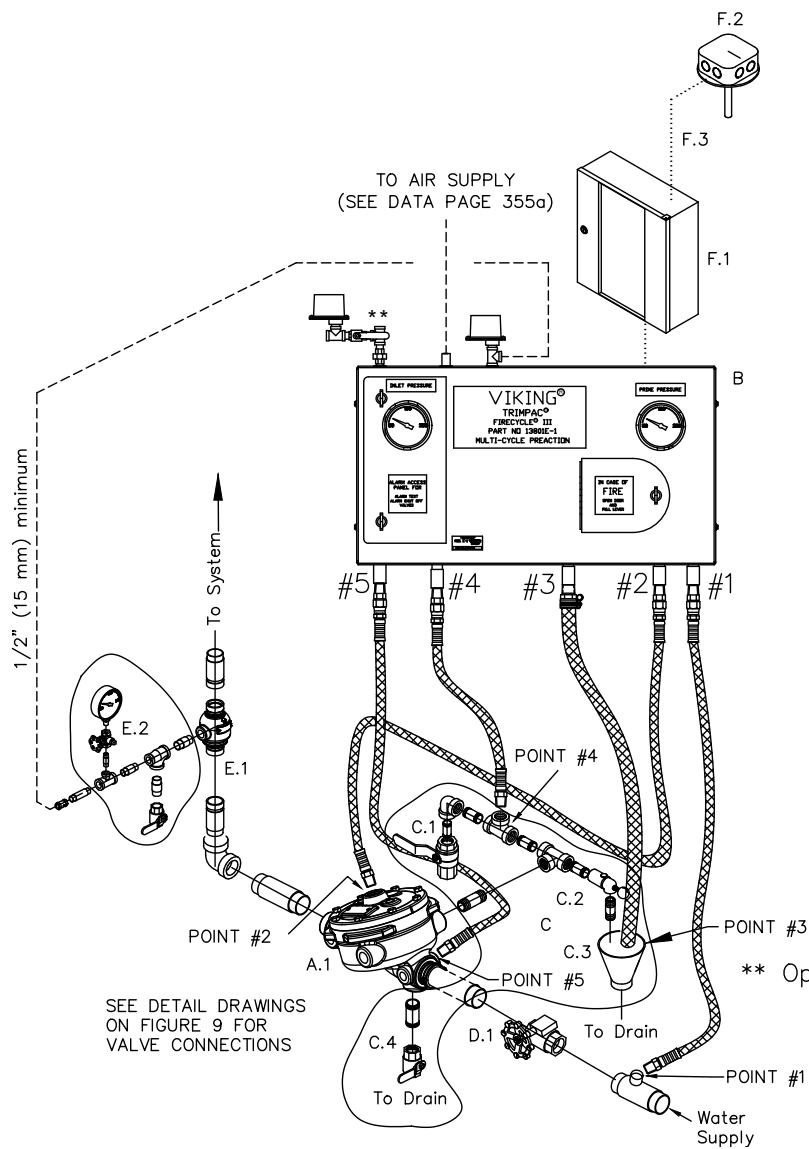

FIRECYCLE® III MULTICYCLE PREACTION

- A System Valve
 - A.1 Flow Control Valve
- B TRIMPAC® Components (See Figure 10)
- C TRIMPAC® Drain Package
 - C.1 Auxiliary Drain Valve (NC)
 - C.2 Drip Check Valve
 - C.3 Drain Cup
 - C.4 Flow Test Valve (NC)
- D Riser
 - D.1 Water Supply Control Valve
- E Check Valve
 - E.1 L-1, K-1, or M-2 Check Valve
 - E.2 Check Valve Trim
- F Release System
 - F.1 VFR-500 Release Control Panel
 - F.2 Firecycle® Detector
 - F.3 Detector Cable

** Optional location for Non-Interruptable Alarm

SEE DETAIL DRAWINGS ON FIGURE 9 FOR VALVE CONNECTIONS

Figure 6
Firecycle® III Preaction System
1-1/2" & 2" Straight-Through Horizontal Valve



TECHNICAL DATA

TRIMPAC® MODEL E-1 & E-1B FIRECYCLE® III MULTI-CYCLE SI & DI PREACTION

The Viking Corporation, 210 N Industrial Park Drive, Hastings MI 49058
 Telephone: 269-945-9501 Technical Services: 877-384-5464 Fax: 269-818-1680 Email: techsvcs@vikingcorp.com
 Visit the Viking website for the latest edition of this technical data page www.vikinggroupinc.com

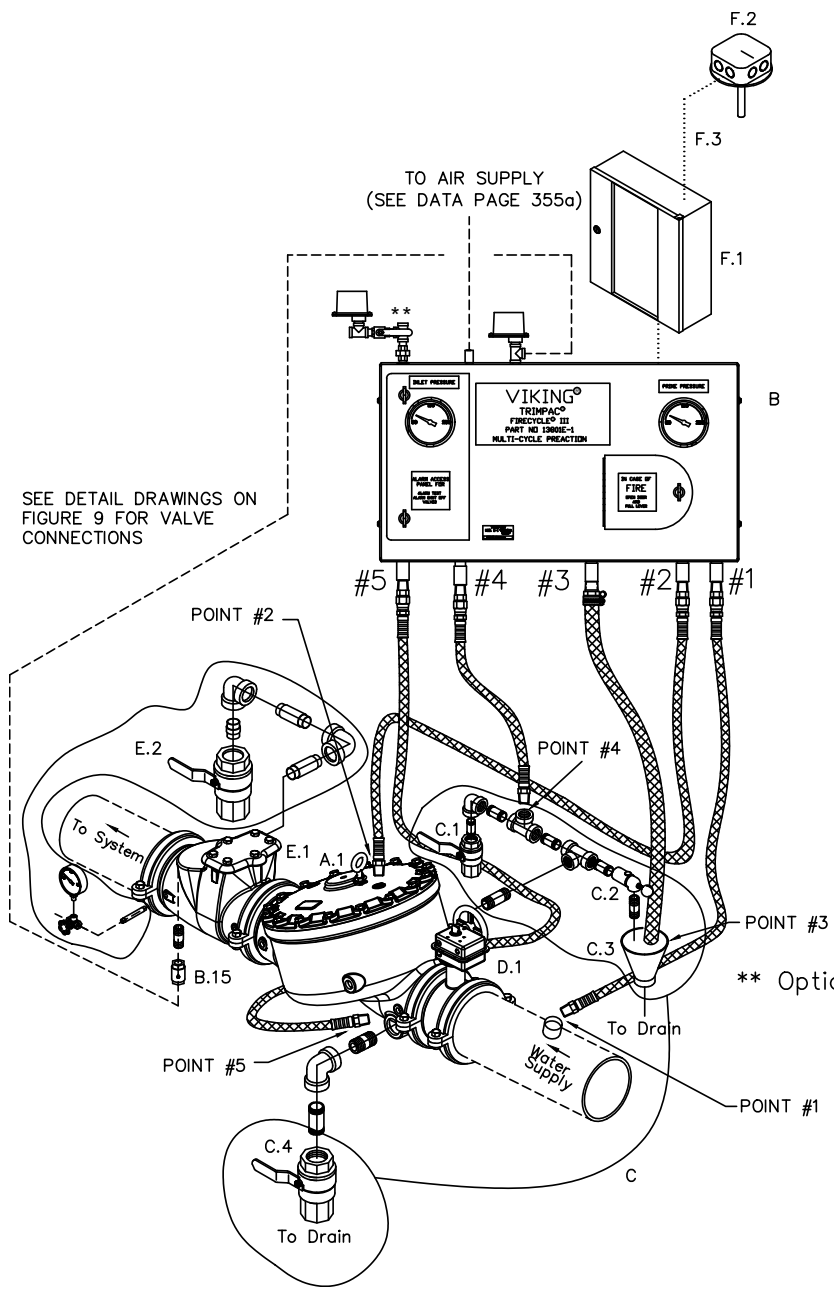

FIRECYCLE® III MULTICYCLE PREACTION

- A System Valve
- A.1 Flow Control Valve
- B TRIMPAC®
- Components (See Figure 10)
- C TRIMPAC® Drain Package
 - C.1 Auxiliary Drain Valve (NC)
 - C.2 Drip Check Valve
 - C.3 Drain Cup
 - C.4 Flow Test Valve (NC)
- D Riser
 - D.1 Water Supply Control Valve
- E Check Valve
 - E.1 Easy Riser Check Valve
 - E.2 Check Valve Trim
- F Release System
 - F.1 VFR-500 Release Control Panel
 - F.2 Firecycle® Detector
 - F.3 Detector Cable

** Optional location for Non-Interruptible Alarm

Figure 8
Firecycle® III Preaction System
8" Straight-Through Horizontal Valve



TECHNICAL DATA

TRIMPAC® MODEL E-1 & E-1B FIRECYCLE® III MULTI-CYCLE SI & DI PREACTION

The Viking Corporation, 210 N Industrial Park Drive, Hastings MI 49058
 Telephone: 269-945-9501 Technical Services: 877-384-5464 Fax: 269-818-1680 Email: techsvcs@vikingcorp.com
 Visit the Viking website for the latest edition of this technical data page www.vikinggroupinc.com

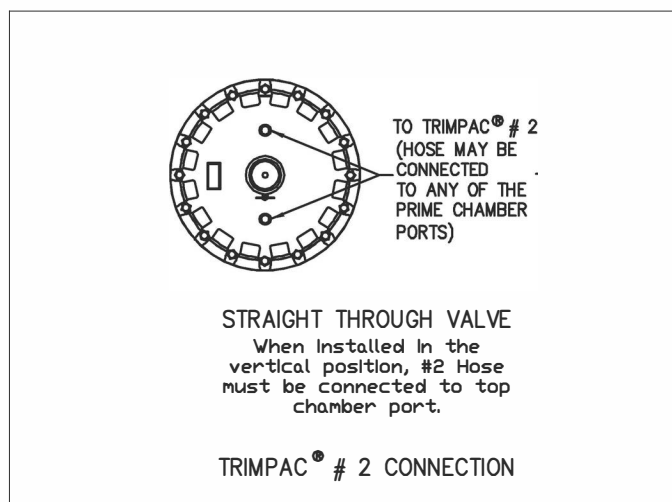
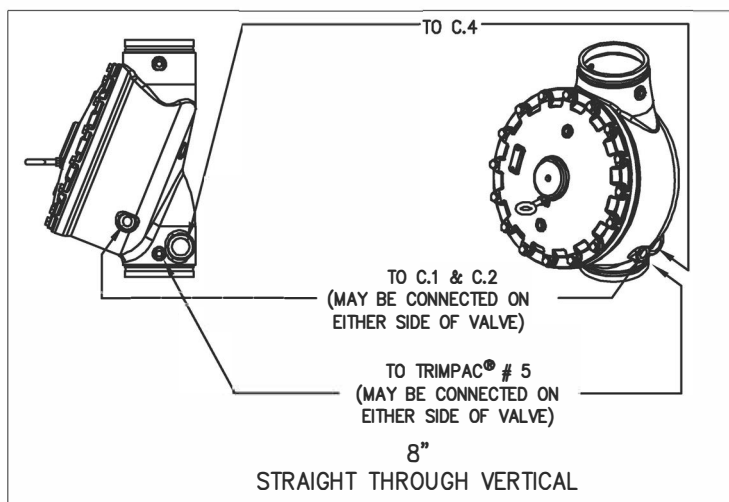
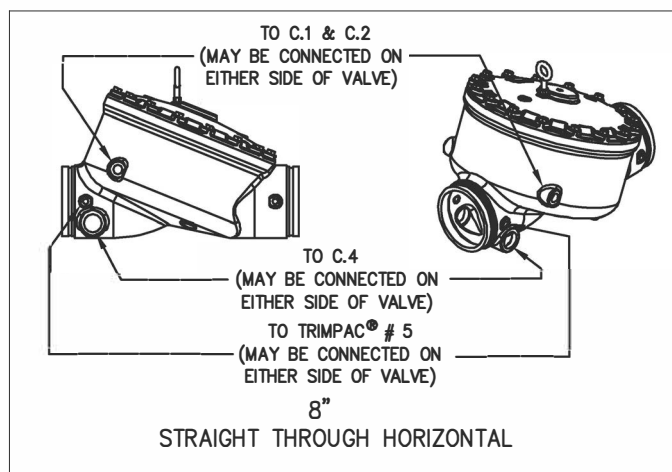
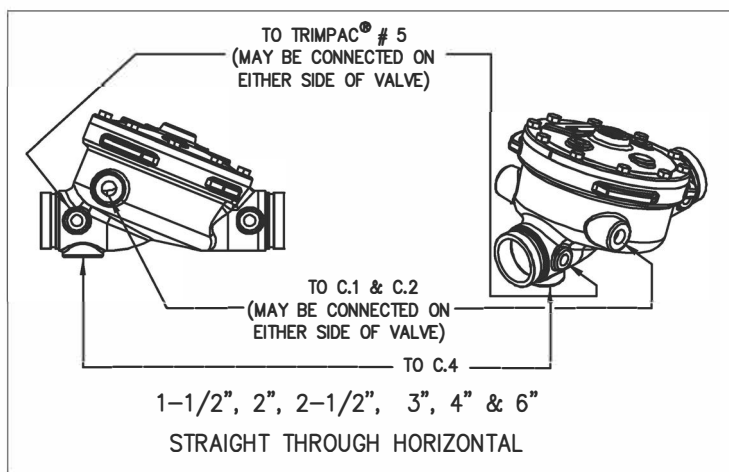
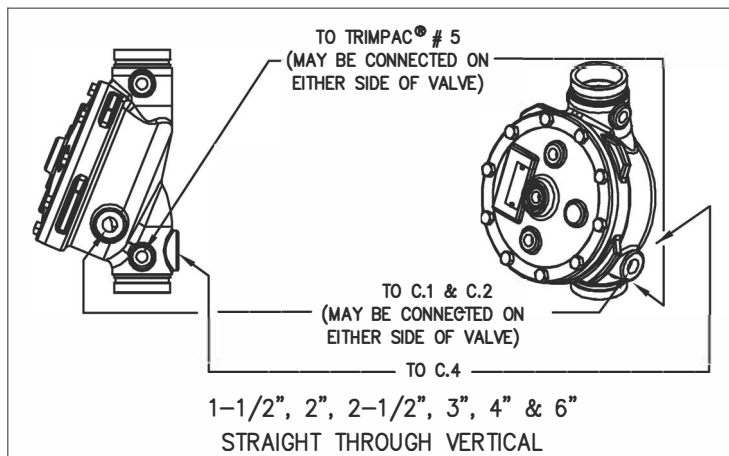

Figure 9 - Valve Connections



TECHNICAL DATA

TRIMPAC® MODEL E-1 & E-1B FIRECYCLE® III MULTI-CYCLE SI & DI PREACTION

The Viking Corporation, 210 N Industrial Park Drive, Hastings MI 49058

Telephone: 269-945-9501 Technical Services: 877-384-5464 Fax: 269-818-1680 Email: techsvcs@vikingcorp.com

Visit the Viking website for the latest edition of this technical data page www.vikinggroupinc.com

NOTE: Emergency release (B.1) is closed when the handle is in-line with the pipe. This allows the door to close when the valve is in the normal position.

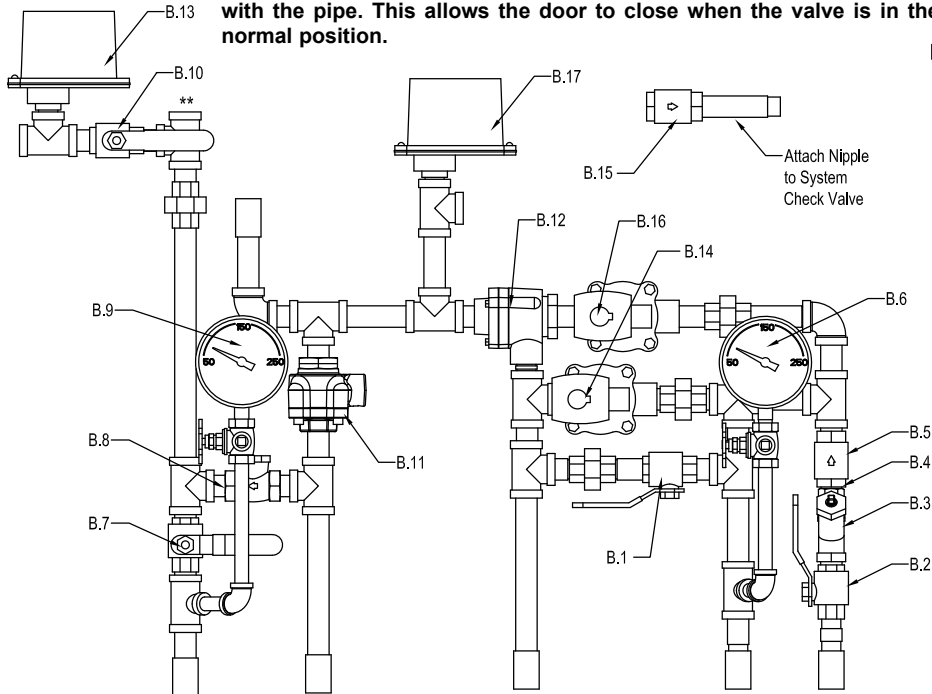

B. TRIMPAC, FIRECYCLE III Preaction

- B.1 Emergency Release (Normally Closed)
 - B.2 Priming Valve (Normally Open)
 - B.3 Strainer
 - B.4 1/8" Restriction
 - B.5 Spring Loaded Check Valve
 - B.6 Priming Pressure Water Gauge and Valve
 - B.7 Alarm Test Valve (Normally Closed)
 - B.8 Drain Check Valve
 - B.9 Water Supply Pressure Gauge and Valve
 - B.10 Alarm Shut-Off Valve (Normally Open)
 - B.11 Pressure Operated Relief Valve (PORV)
 - B.12 Pneumatic Actuator
 - B.13 Water Flow Alarm Pressure Switch (Optional)
 - B.14 Solenoid Valve (Normally Closed)
 - B.15 Spring Loaded Check Valve
 - B.16 Solenoid Valve (Normally Open)
 - B.17 Air Pressure Supervisory Switch
- ** Optional location for non-interruptible Alarm Switch

Figure 10 - TRIMPAC® Components (Items B.1 - B.17)

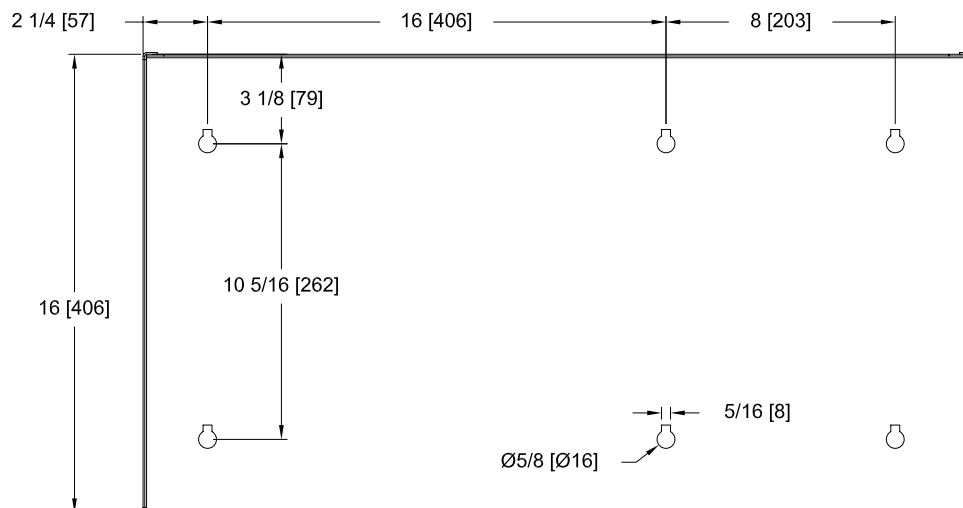

Figure 11 - Mounting Dimensions

Wall Mounting Notes:

1. Mounting Fasteners are supplied by the contractor.
2. Recommended Fasteners - Minimum 1/4" x 1-1/2 Lg. Hex Head lag screws with washers.
3. When installing into concrete, drywall or metal, use typical grommet.
4. Approximate Weight of TRIMPAC® Model E-1 & E-1B and Flexible Hoses: 34 lbs. (15.4 kg)



TECHNICAL DATA

TRIMPAC® MODEL E-1 & E-1B FIRECYCLE® III MULTI-CYCLE SI & DI PREACTION

The Viking Corporation, 210 N Industrial Park Drive, Hastings MI 49058
 Telephone: 269-945-9501 Technical Services: 877-384-5464 Fax: 269-818-1680 Email: techsvcs@vikingcorp.com
 Visit the Viking website for the latest edition of this technical data page www.vikinggroupinc.com

TRIMPAC® DRAIN PACKAGE PART NUMBERS			
Valve	Size	Galvanized	Brass
Straight	8" (DN200)	11894-4	11894-8

8" (DN200) Straight-Through Vertical Valve Drain Package Trim Chart

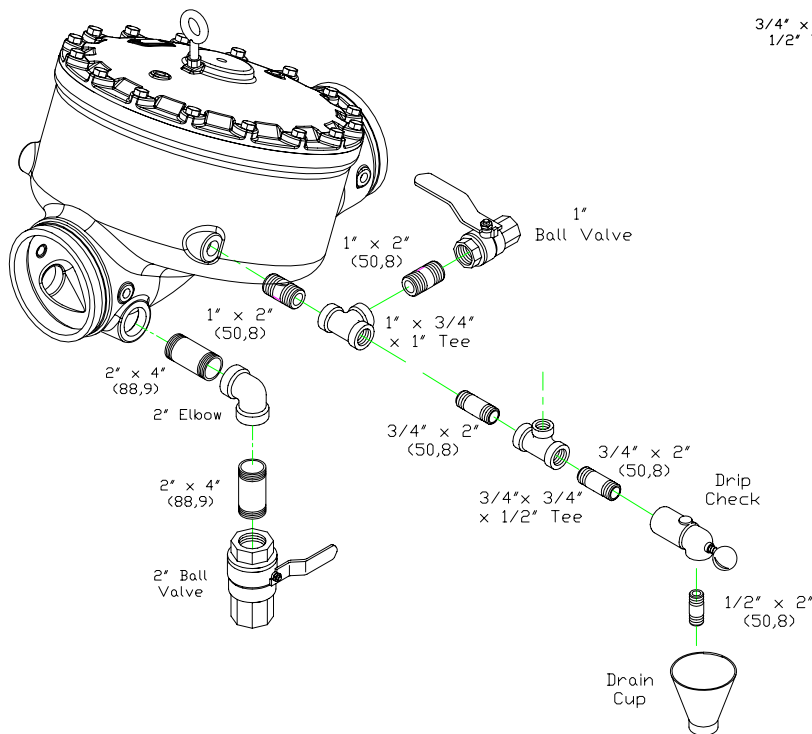
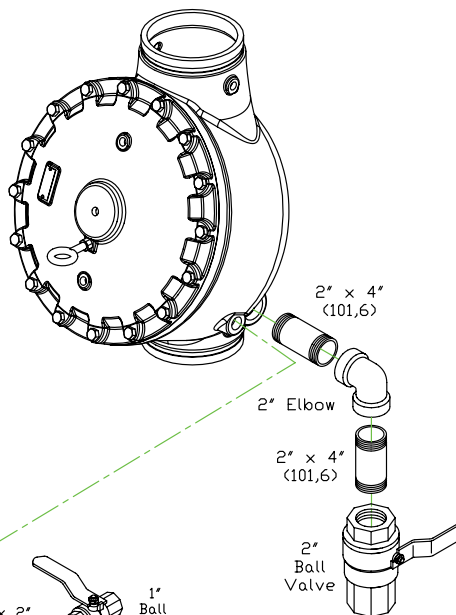

8" (DN200) Straight-Through Horizontal Valve Drain Package Trim Chart

Figure 13