



TECHNICAL DATA

TRIMPAC® MODEL E-3 FIRECYCLE® III MULTI-CYCLE WET

The Viking Corporation, 210 N Industrial Park Drive, Hastings MI 49058

Telephone: 269-945-9501 Technical Services: 877-384-5464 Fax: 269-818-1680 Email: techsvcs@vikingcorp.com

Visit the Viking website for the latest edition of this technical data page www.vikinggroupinc.com

1. DESCRIPTION

The Viking Firecycle® III Multi-Cycle Wet System utilizes a Viking Model J Flow Control Valve and a VFR-500 Control Panel with additional valves, devices, and trim to form a unique operating system.

The cycling wet configuration operates the Firecycle® III System as a normal wet pipe system with the abilities to sense when the fire has been controlled and to turn off the water flow automatically after a pre-programmed "Soak Timer" has been satisfied. If the fire rekindles, Firecycle® III will initiate the sequence again. This unique cycling feature will continue to operate as long as necessary, provided that the panel receives power, and helps to minimize water usage, water damage, and the threat of pollution to surrounding areas. Batteries are available to provide up to ninety (90) hours of emergency power. If the AC power fails and the battery backup power expires while the system is operating, the system will "fail-safe", and continue flowing until AC power is restored or the system is manually shut-off.

The Firecycle® III Cycling Wet Pipe System has several "fail-safe" features

that are not available on standard wet pipe systems. Refer to section 5. Operation for details. TRIMPAC® Model E-3 is a trim package for a Firecycle® III and Firecycle® III-OH System and is manufactured and factory leak tested in a metal enclosure. The standard trim normally required on a Firecycle® III and Firecycle® III-OH System has been preassembled into a single cabinet. TRIMPAC® Model E-3 provides access doors for the emergency release and alarm test valve for manual operation of these trim valves. TRIMPAC® Model E-3 is equipped with a priming water pressure gauge view-ports for easy monitoring of water pressures, and with a monitored solenoid (NC) or a non-monitored solenoid (NO). TRIMPAC® Model E-3 eliminates the installation of alarm trim piping and release trim piping at the flow control valve. The enclosure protects trim valves from inadvertent operation. The included stainless steel hoses (or field provided hard piping) from the valve body to the enclosure assembly allows the assembly to be installed remote of the sprinkler system riser. A Water Flow and Alarm Switch and System Drain Package is required and is to be ordered based on the flow control valve size.



2. LISTINGS AND APPROVALS

UL listed - VLTR

3. TECHNICAL DATA

Specifications:

Rated Water Working Pressure: 250 psi (17.2 bar)

Gauges: 0-300 PSI

Weight: 55 lbs. (24.9 kg.)

Dimensions: 16-1/8" (409 mm) high x 29-1/8" (748 mm) wide x 8-25/32" (223 mm) deep

Material Standards:

Enclosure: 6 gauge steel, painted red: Epoxy Powder Coat

Solenoid Valves (1 NC, 1 NO):

- Monitored Solenoid (NC): Brass body, 24 VDC, 5-300 PSI (0.34-20.7 bar), NEMA Rated 2, 3, 3S, 4, 4X, 9.0 Watts
- Non-Monitored Solenoids (NO): Brass Body 1/2" (1.27 cm), 24 Volt DC, 250 psi (17.2 bar), NEMA Rated 1, 2, 3, 3S, 4 or 4X, 10 Watts

Ball valves: 1/2" NPT female ends

Strainer: Brass Body, 1/2" NPT inlet and outlet, 50 mesh screen

Restricted orifice: Brass Body, 1/2" NPT female inlet, 1/2" NPT male outlet, 0.0625" orifice

Spring Loaded Check Valve: Brass Body, 1/2" NPT female inlet and outlet

Hoses (3): Flexible braided stainless steel hoses with steel fittings and connectors, PTFE lined

Trim Piping: 1/2" galvanized or 1/2" brass

Fittings: 1/2" galvanized

Ordering Information: Refer to Table 1.

Accessories:

- Vertical Mounting Plate Kit - Part No. 11900
- Horizontal Mounting Plate Kit - Part No. 11901
- Hose Assembly Kit (Includes (4) Stainless Steel Hoses and (1) PVC Drain Hose) - Part No. 12072 (included with Part Nos. 13802E-2 and 13802E-2B)
- Individual 5'-0" Stainless Steel & PTFE Hose: Part No. 16558 (3 required)
- Individual PVC Hose: Part No. 12071 (1 required)



TECHNICAL DATA

TRIMPAC® MODEL E-3 FIRECYCLE® III MULTI-CYCLE WET

The Viking Corporation, 210 N Industrial Park Drive, Hastings MI 49058

Telephone: 269-945-9501 Technical Services: 877-384-5464 Fax: 269-818-1680 Email: techsvcs@vikingcorp.com

Visit the Viking website for the latest edition of this technical data page www.vikinggroupinc.com

4. INSTALLATION (Refer to Figures 3 - 10 for identification of trim components. Refer to Figure 11 for wall-mounting.)

1. TRIMPAC® Model E-3 Trim Assemblies may be installed with the Model J Straight-Through Flow Control valves, sizes 1-1/2", 2", 2-1/2", 3", 4", 6", and 8".

NOTE: WHEN TRIMPAC™ MODEL E-3 IS UTILIZED WITH THE MODEL J FLOW CONTROL VALVE, REMOTE OR AUTOMATIC ON/OFF OPERATION OF THE FLOW CONTROL VALVE CANNOT BE ACCOMPLISHED.

2. TRIMPAC® Model E-3 trim assembly and valve must be installed in an area not subject to freezing.
3. TRIMPAC® Model E-3 trim assembly must be installed to facilitate drainage.
4. TRIMPAC® Model E-3 trim assembly must be installed above the elevation of the valve. (Bottom of TRIMPAC® Model E-3 to top of valve cover.)
5. TRIMPAC® Model E-3 trim assembly can be installed with the furnished hose package or 1/2" non-corrosive metallic piping. The maximum distance the TRIMPAC® Model E-3 may be installed away from the flow control valve is 5'-0".
6. The flow control valve equipped with TRIMPAC® Model E-3 must be installed in accordance with Viking Technical data. The required water flow indicator and system drain valve package must be installed in accordance with applicable trim data pages.
 - a. Remove all plastic thread protectors from the openings of the flow control valve and the TRIMPAC® Model E-3 trim assembly.
 - b. Apply a small amount of pipe-joint compound or tape to the external threads of all pipe connections required. Take care not to allow any compound, tape, or other foreign matter inside any of the nipples or openings of the valve or trim components.
 - c. Verify that all system components are rated for the water working pressure of the system.

Hydrostatic Test:

The Viking flow control valve is manufactured and listed for use at a maximum Water Working Pressure of 250 PSI (17.2 bar). The valve is factory tested at 500 psi (34.5 bar). The Viking flow control valve may be hydrostatically tested at 300 PSI (20.7 bar) and/or 50 PSI (3.5 bar) above the normal Water Working Pressure, for limited periods of time (2 hours) for the purpose of acceptance by the Authority Having Jurisdiction. If air testing is required, DO NOT exceed 40 psi (2.8 bar) air pressure.

Trim Note: (Refer also to System Data and/or Trim Chart.)

Discharge piping from all system drains should be kept separate.

7. The priming line (#1) must be connected upstream of the system water supply main control valve.
8. After the flow control valve is set, operation requires the release of priming water from the priming chamber. For TRIMPAC® Model E-3 the release of the priming water from the priming chamber will be automatically controlled by the pneumatic release system that is installed in the hazard area. Upon activation of the automatic pneumatic release system, air pressure will be relieved from the normally closed pneumatic actuator in the TRIMPAC® Model E-3, allowing it to open, which will then relieve priming water pressure from the priming chamber.

CAUTION

Operation of Viking flow control valve by pressurizing the priming chamber with air pressure or any other pressurized gas is not recommended or approved.

9. Placing the System in Service: (Refer to Figures 3 - 10.)
 - a. Verify that the system has been properly drained. Open the Emergency Release (B.1).
 - b. Open the VFR-500 Release Control Panel (E.1) and press "RESET." Release Solenoid Valve #1 (B.7) should close.
 - c. Fully open and secure the Main Water Supply Control Valve (D.1).
 - d. Close the Emergency Release (B.1).
 - e. Verify that all valves are secured in their normal operating position.

5. OPERATION (Refer to Figures 3 - 10.)

System water supply pressure enters the priming chamber of the Flow Control Valve (A.1) through the 1/2" (13 mm) priming line, which includes a Strainer (B.3), restricted orifice (B.4), normally open priming valve (B.2) and Check Valve (B.5). Normally open Release Solenoid Valve #2 (B.8) allows priming water to escape so that the Flow Control Valve (A.1) will not set, but remain open, filling the system piping with water.

In fire conditions:

When the Firecycle® III detection system (E.2 and E.3) operates, the VFR-500 Release Control Panel (E.1) activates a piezo sounder and energizes normally closed Release Solenoid Valve #1 (B.7) open and normally open Release Solenoid Valve #2 (B.8) closed. Pressure continues to be released from the priming chamber faster than it is supplied through the restricted orifice (B.4). The Flow Control Valve (A.1) clapper remains fully open to allow water to flow through the system piping and to activate alarm devices, including a Water Flow and Alarm Switch (C.1). Water will immediately flow from any sprinklers attached to the system that may have operated. Water Flow and Alarm Switch (C.1) activates, latching normally open Release Solenoid Valve #2 (B.8) closed. Water discharges until all Firecycle® Detectors have reset (cooled below their set point). After all detectors have reset, the VFR-500 Control Panel (E.1) activates the "Soak Timer", allowing the system to continue discharging water for a preset time period. When the "Soak Timer" has



TECHNICAL DATA

TRIMPAC® MODEL E-3
FIRECYCLE® III MULTI-CYCLE WET

The Viking Corporation, 210 N Industrial Park Drive, Hastings MI 49058

Telephone: 269-945-9501 Technical Services: 877-384-5464 Fax: 269-818-1680 Email: techsvcs@vikingcorp.com

Visit the Viking website for the latest edition of this technical data page www.vikinggroupinc.com

expired, the VFR-500 Control Panel (E.1) de-energizes normally closed Release Solenoid Valve #1 (B.7), allowing it to close. (The normally open Release Solenoid Valve #2 (B.8) remains energized closed until the VFR-500 Control Panel is manually reset, or both AC power and battery backup have failed.) The Flow Control Valve (A.1) re-primed and closes, stopping the flow of water through the system piping.

If a Firecycle® Detector goes into alarm at this time, the VFR-500 Release Control Panel (E.1) re-energizes normally closed Release Solenoid Valve #1 (B.7) open, and the entire cycle repeats.

To return the system to "Normal" conditions, drain the system piping and replace any sprinklers that may have operated, and any Firecycle® Detectors that have been damaged. Open the Emergency Release (B.1) to allow the system pressure to return to normal. Once the pressure has stabilized, close the Emergency Release (B.1) and press the "System Reset" button on the VFR-500 Control Panel (E.1).

Trouble conditions:

If the detection system is damaged or malfunctions, the VFR-500 Control Panel will initiate the appropriate alarms, and the Flow Control Valve (A.1) will open. Water will not flow from any sprinklers until a sprinkler has operated, as in a fire. The cycling function of the Firecycle® III or Firecycle® III-OH System will not operate in this condition, and the system must be manually shut off. All alarms will operate normally.

If the piping system is damaged sufficiently to activate the Water Flow and Alarm Switch (C.1), the VFR-500 Control Panel (E.1) will energize normally open Release Solenoid Valve #2 (B.8) closed. Because a detector has not gone into alarm mode, Release Solenoid Valve #1 (B.7) will remain energized closed. The Flow Control Valve (A.1) will re-prime and close after a short delay. If a sprinkler or the system piping is damaged, this feature ensures that the amount of discharging water is limited by the system pressure and the location of the system damage. If a Firecycle® Detector detects a fire during this condition, the normally closed Release Solenoid Valve #1 (B.7) will be energized open, allowing the Flow Control Valve (A.1) to open, and water will be discharged from any sprinklers that may have operated as a result of the fire, as well as from the damaged portion of the system. The cycling function of the Firecycle® III or Firecycle® III-OH System and all alarms will operate normally in this condition.

Loss of Power Prior to Operation:

If the AC power fails, the Firecycle® III or Firecycle® III-OH System continues to operate on the stand-by batteries. The VFR-500 Control Panel will initiate a trouble alarm. If the AC power and the standby batteries fail prior to the operation of the system, all alarms would be lost. The cycling function of the system will be lost, and the system will operate as a typical wet system. The system will not cycle and must be manually shut-off.

Loss of Power During Operation:

If all power fails while the system is flowing water, the system will not cycle off, and must be manually shut-off.

Manual Operation:

Any time the handle inside Emergency Release (B.1) is pulled, pressure is released from the priming chamber faster than it can be replaced through the priming line; the Flow Control Valve (A.1) will open. Water will flow into the system piping and will be discharged from any open sprinklers. After operating the Emergency Release (B.1), DO NOT close the Emergency Release until the system is ready to be reset.

6. INSPECTIONS, TESTS, AND MAINTENANCE

It is imperative that the system be inspected and tested on a regular basis. The frequency of the inspections may vary due to contaminated water supplies, corrosive water supplies, or corrosive atmospheres. Also, the alarm devices, detection systems, or other connected trim may require a more frequent schedule. For minimum maintenance and inspection requirements, refer to NFPA 25. In addition, the Authority Having Jurisdiction may have additional maintenance, testing, and inspection requirements that must be followed. Refer to the specific Viking flow control valve data page for periodic testing.

Maintenance:

TRIMPAC® Model E-3 should be inspected, tested, and maintained in accordance with the latest edition of NFPA 25, The Standard for Inspection, Testing, and Maintenance of water based fire protection systems, and in accordance with the Authority Having Jurisdiction.



TECHNICAL DATA

TRIMPAC® MODEL E-3 FIRECYCLE® III MULTI-CYCLE WET

The Viking Corporation, 210 N Industrial Park Drive, Hastings MI 49058

Telephone: 269-945-9501 Technical Services: 877-384-5464 Fax: 269-818-1680 Email: techsvcs@vikingcorp.com

Visit the Viking website for the latest edition of this technical data page www.vikinggroupinc.com

NOTICE

The owner is responsible for maintaining the fire protection system and devices in proper operating condition. The flow control valve must be kept from freezing conditions and physical damage that could impair its operation. Contact the valve manufacturer or authorized representative when performance difficulty occurs and field adjustment is needed.

WARNING

Any system maintenance that involves placing a control valve or detection system out of service may eliminate the fire protection capabilities of that system. Prior to proceeding, notify all Authorities Having Jurisdiction. Consideration should be given to employment of a fire patrol in the affected areas.

After Each Operation:

1. Sprinkler systems that have been subjected to a fire must be returned to service as soon as possible. The entire system must be inspected for damage, and repaired or replaced as necessary.
2. Flow control valves and TRIMPAC® Model E-3 that have been subjected to brackish water, salt water, foam, foam/water solution, or any other corrosive water supply should be flushed with good quality fresh water before being returned to service. Refer to specific flow control valve for maintenance schedule.

7. AVAILABILITY

The Viking TRIMPAC® Model E-3 is available through a network of domestic and international distributors. See the Viking Corp. website for closest distributor or contact The Viking Corporation.

8. GUARANTEE

For details of warranty, refer to Viking's current list price schedule or contact Viking directly.

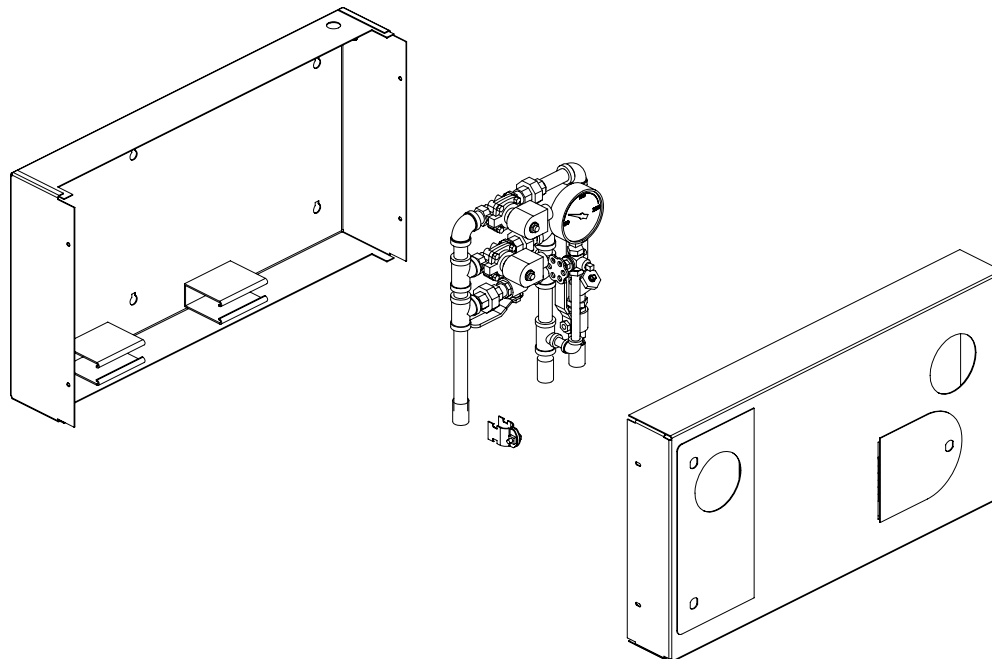

Figure 1 - Isometric View



TECHNICAL DATA

TRIMPAC® MODEL E-3 FIRECYCLE® III MULTI-CYCLE WET

The Viking Corporation, 210 N Industrial Park Drive, Hastings MI 49058
 Telephone: 269-945-9501 Technical Services: 877-384-5464 Fax: 269-818-1680 Email: techsvcs@vikingcorp.com
 Visit the Viking website for the latest edition of this technical data page www.vikinggroupinc.com

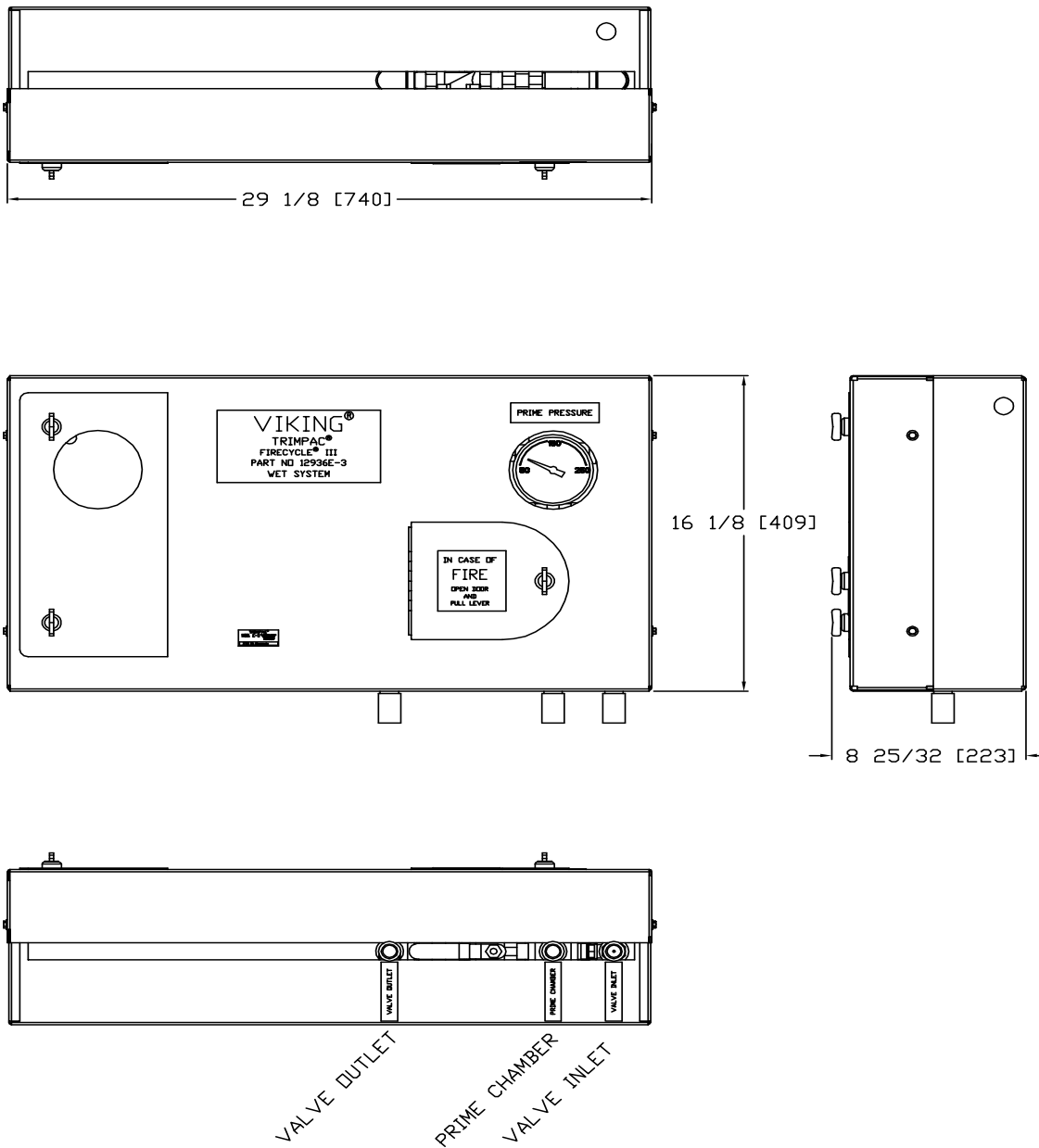

Figure 2 - TRIMPAC® Model E-3 Dimensions



TECHNICAL DATA

TRIMPAC® MODEL E-3 FIRECYCLE® III MULTI-CYCLE WET

The Viking Corporation, 210 N Industrial Park Drive, Hastings MI 49058
 Telephone: 269-945-9501 Technical Services: 877-384-5464 Fax: 269-818-1680 Email: techsvcs@vikingcorp.com
 Visit the Viking website for the latest edition of this technical data page www.vikinggroupinc.com

Ordering Information

Component	Description	Part Numbers		Corresponding Data Pages																
System Valve																				
A	A.1	Flow Control Valve	Various		F_040304 F_040402 F_040404 F_040502															
	TRIMPAC®		12936E-3	--																
12936E-3B (Brass available by special order)																				
28184E-3*																				
28184E3B*																				
*Note: Monitored solenoid option: Each of the above configurations can be ordered with a monitored or non-monitored release solenoid. The monitored solenoid is a new option, which offers an NFPA 13 solenoid monitoring-compliant solution.																				
B.1 - B.8	TRIMPAC® Components	Refer to Figure 10.																		
TRIMPAC® Water Flow & Alarm Switch and Drain Package																				
C	C.1	Water Flow and Alarm Switch	<table border="1"> <thead> <tr> <th>Galvanized</th> <th>Brass</th> </tr> </thead> <tbody> <tr> <td>1-1/2": 12961-2</td> <td>1-1/2": 12961-10</td> </tr> <tr> <td>2": 12961-3</td> <td>2": 12961-11</td> </tr> <tr> <td>2-1/2": 12961-4</td> <td>2-1/2": 12961-12</td> </tr> <tr> <td>3": 12961-5</td> <td>3": 12961-13</td> </tr> <tr> <td>4": 12961-6</td> <td>4": 12961-14</td> </tr> <tr> <td>6": 12961-7</td> <td>6": 12961-15</td> </tr> <tr> <td>8": 12961-8</td> <td>8": 12961-16</td> </tr> </tbody> </table>	Galvanized	Brass	1-1/2": 12961-2	1-1/2": 12961-10	2": 12961-3	2": 12961-11	2-1/2": 12961-4	2-1/2": 12961-12	3": 12961-5	3": 12961-13	4": 12961-6	4": 12961-14	6": 12961-7	6": 12961-15	8": 12961-8	8": 12961-16	--
	Galvanized	Brass																		
1-1/2": 12961-2	1-1/2": 12961-10																			
2": 12961-3	2": 12961-11																			
2-1/2": 12961-4	2-1/2": 12961-12																			
3": 12961-5	3": 12961-13																			
4": 12961-6	4": 12961-14																			
6": 12961-7	6": 12961-15																			
8": 12961-8	8": 12961-16																			
C.2	Sprinkler System Main Drain and Trim																			
Riser																				
D	D.1	Water Supply Control Valve	Various		Refer to manufacturer's documentation**															
	**For questions, contact Viking Tech Services.																			
D.2	System Water Supply Gauge & Valve	--		--																
Release System																				
E.1	VFR-500 Multi-Hazard Release Control Panel	26107		F_081022																
E.2	Firecycle® Detectors	Firecycle® III Model B	Various		F_071697															
		Firecycle® OH Model C	Various		F_040902															
E.3	Detector Cables	FPL Cable	16 Gauge - 19749 18 Gauge - 19750	F_031915																
Table 1 - TRIMPAC® System Components Refer to Figures 3 through 10 for component Identification.																				





TECHNICAL DATA

TRIMPAC® MODEL E-3 FIRECYCLE® III MULTI-CYCLE WET

The Viking Corporation, 210 N Industrial Park Drive, Hastings MI 49058
 Telephone: 269-945-9501 Technical Services: 877-384-5464 Fax: 269-818-1680 Email: techsvcs@vikingcorp.com
 Visit the Viking website for the latest edition of this technical data page www.vikinggroupinc.com

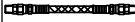
Legend for Figures 3 - 8

- Dashed lines indicate pipe required but not included with TRIMPAC trim packages. Minimum 1/2" nominal piping recommended.
-  Smaller diameter hoses are the (4) included flexible braided stainless steel hoses. Also available as a kit (P/N) 12072
-  Larger diameter hose is the included PVC Drain Hose. Also available separately (P/N) 12071
- ** 1/2" (15 mm) NPT for non-interruptible Alarm Pressure Switch (Optional)

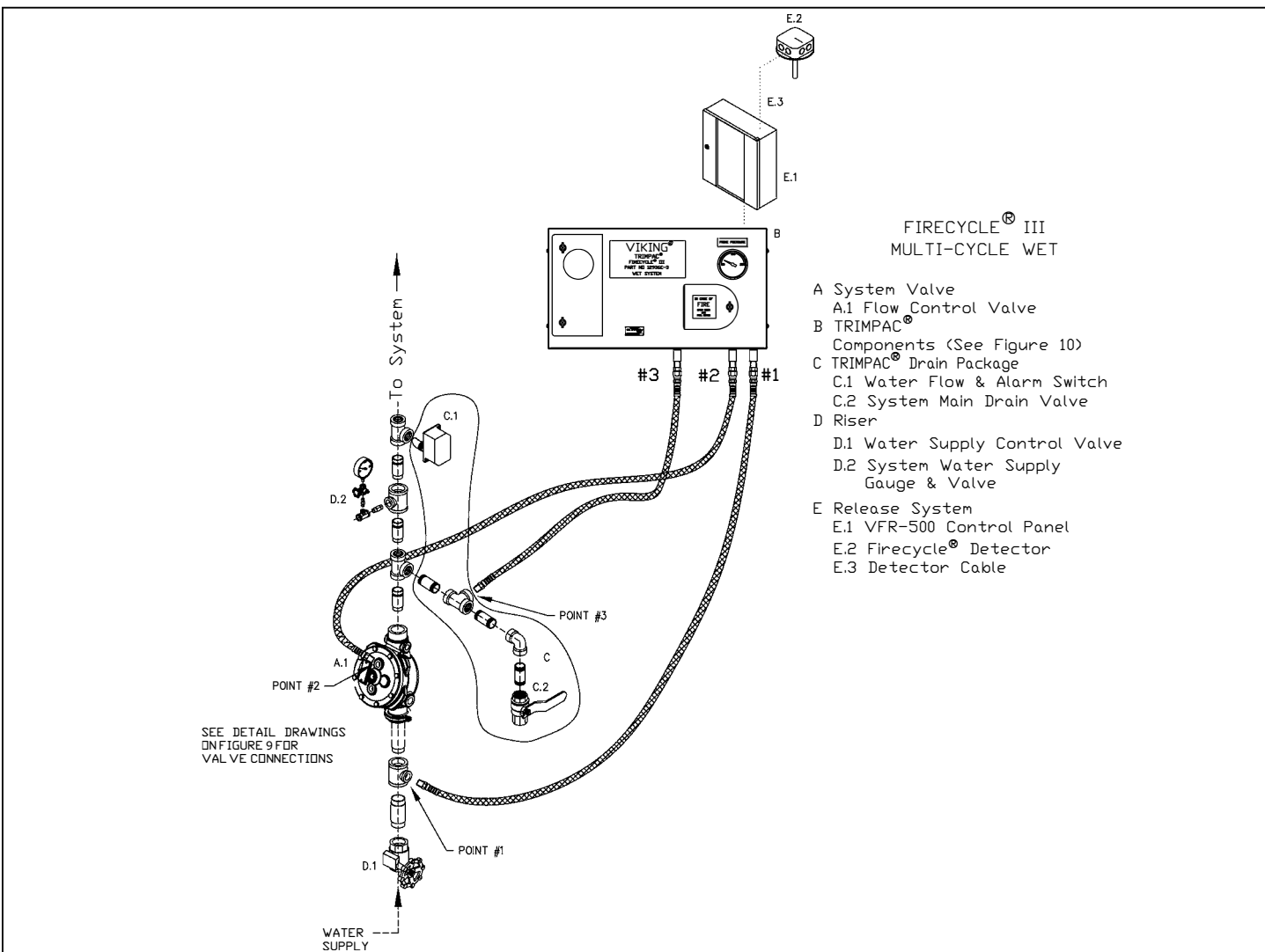

Figure 3
Firecycle® III Wet System
1-1/2" & 2" Straight-Through Vertical Valve



TECHNICAL DATA

TRIMPAC® MODEL E-3 FIRECYCLE® III MULTI-CYCLE WET

The Viking Corporation, 210 N Industrial Park Drive, Hastings MI 49058
 Telephone: 269-945-9501 Technical Services: 877-384-5464 Fax: 269-818-1680 Email: techsvcs@vikingcorp.com
 Visit the Viking website for the latest edition of this technical data page www.vikinggroupinc.com

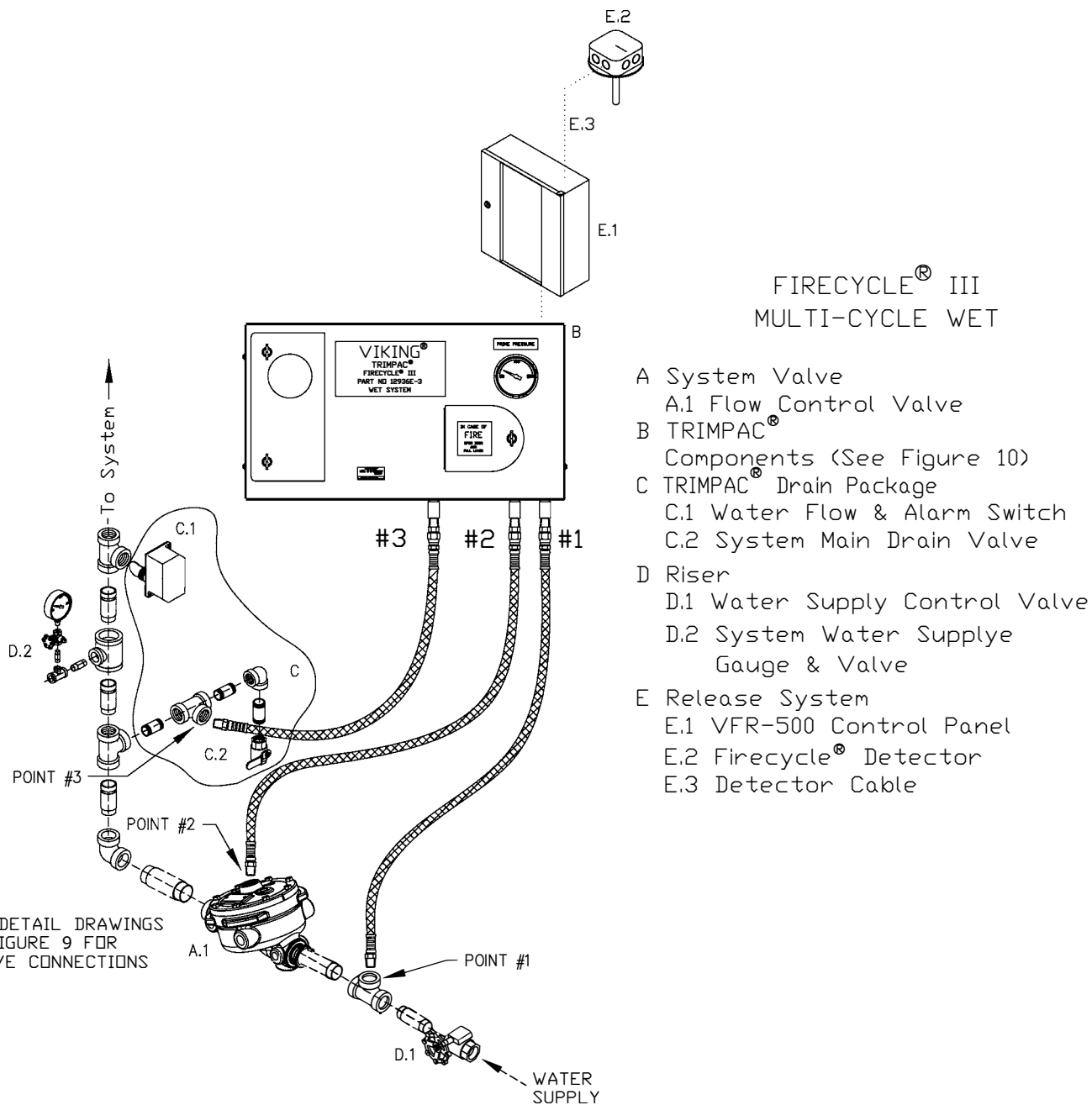

FIRECYCLE® III MULTI-CYCLE WET

- A System Valve
 - A.1 Flow Control Valve
- B TRIMPAC® Components (See Figure 10)
- C TRIMPAC® Drain Package
 - C.1 Water Flow & Alarm Switch
 - C.2 System Main Drain Valve
- D Riser
 - D.1 Water Supply Control Valve
 - D.2 System Water Supply Gauge & Valve
- E Release System
 - E.1 VFR-500 Control Panel
 - E.2 Firecycle® Detector
 - E.3 Detector Cable

Figure 4
Firecycle® III Wet System
1-1/2" & 2" Straight-Through Horizontal Valve



TECHNICAL DATA

TRIMPAC® MODEL E-3 FIRECYCLE® III MULTI-CYCLE WET

The Viking Corporation, 210 N Industrial Park Drive, Hastings MI 49058
 Telephone: 269-945-9501 Technical Services: 877-384-5464 Fax: 269-818-1680 Email: techsvcs@vikingcorp.com
 Visit the Viking website for the latest edition of this technical data page www.vikinggroupinc.com

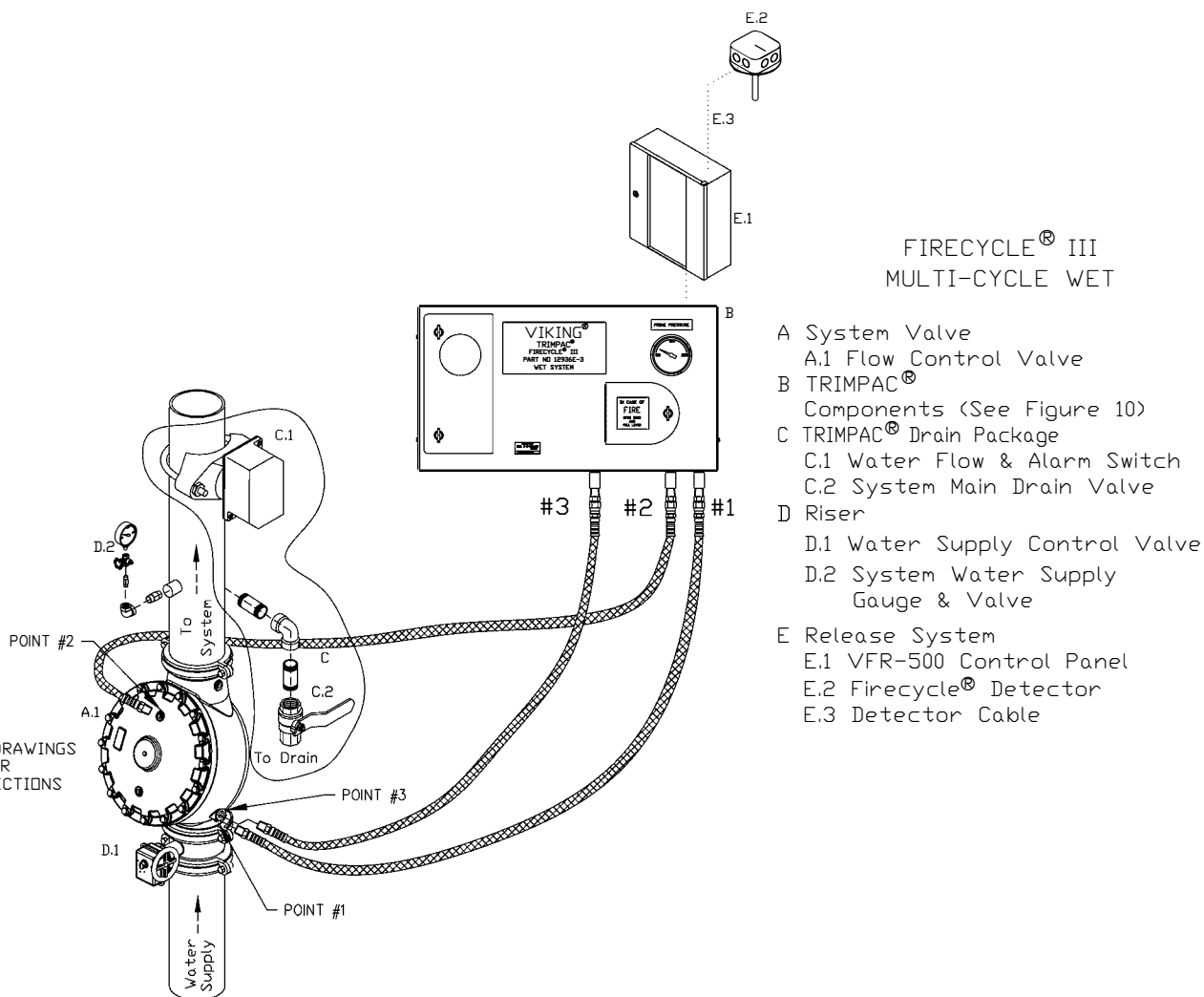

Figure 5
Firecycle® III Wet System
2-1/2" - 6" Straight-Through Vertical Valve



TECHNICAL DATA

TRIMPAC® MODEL E-3 FIRECYCLE® III MULTI-CYCLE WET

The Viking Corporation, 210 N Industrial Park Drive, Hastings MI 49058
 Telephone: 269-945-9501 Technical Services: 877-384-5464 Fax: 269-818-1680 Email: techsvcs@vikingcorp.com
 Visit the Viking website for the latest edition of this technical data page www.vikinggroupinc.com

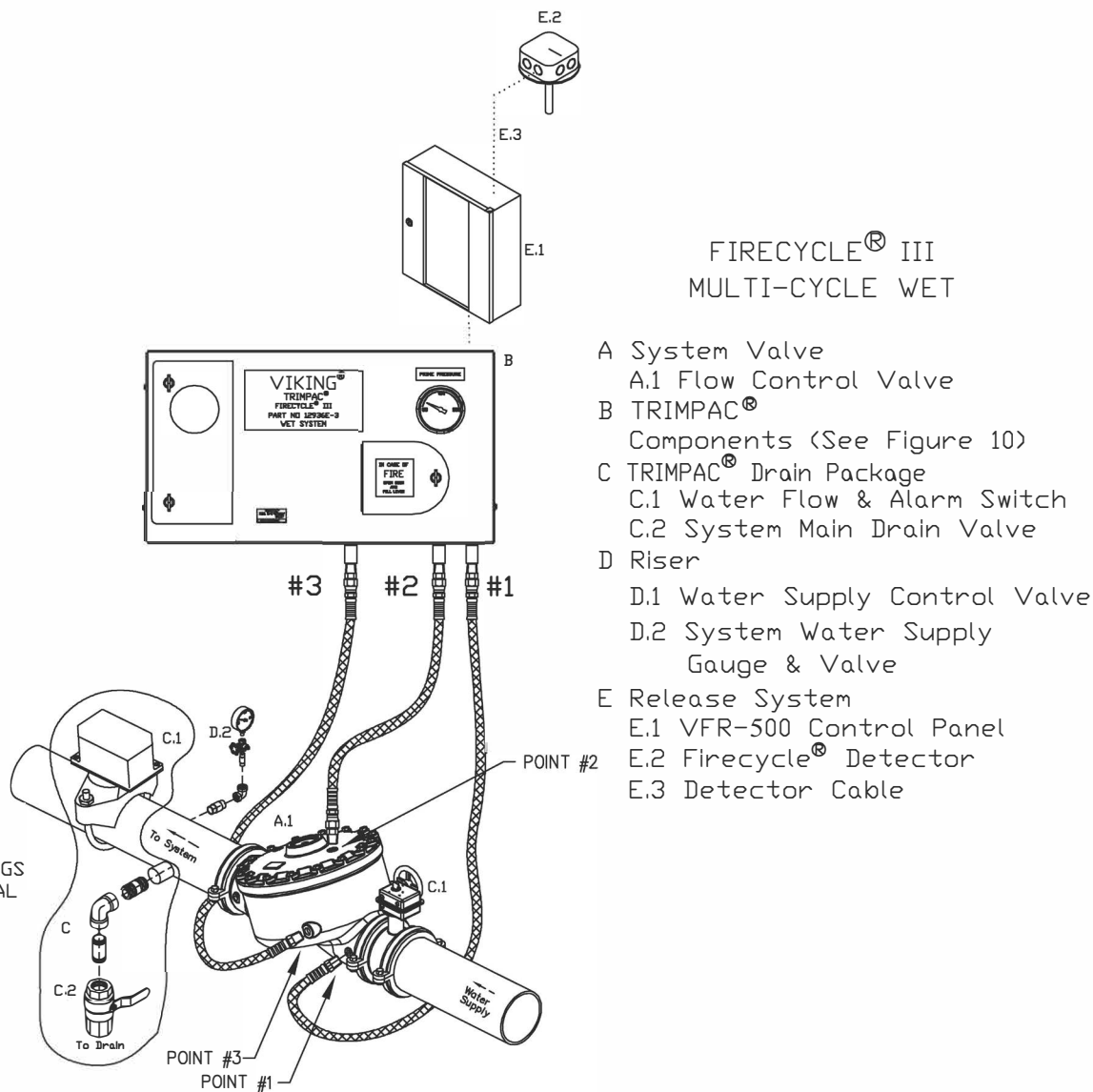

SEE DETAIL DRAWINGS
ON FIGURE 9 FOR VAL
VE CONNECTIONS

- FIRECYCLE® III
MULTI-CYCLE WET
- A System Valve
 - A.1 Flow Control Valve
 - B TRIMPAC®
 - Components (See Figure 10)
 - C TRIMPAC® Drain Package
 - C.1 Water Flow & Alarm Switch
 - C.2 System Main Drain Valve
 - D Riser
 - D.1 Water Supply Control Valve
 - D.2 System Water Supply Gauge & Valve
 - E Release System
 - E.1 VFR-500 Control Panel
 - E.2 Firecycle® Detector
 - E.3 Detector Cable

Figure 6
Firecycle® III Wet System
2-1/2" - 6" Straight-Through Horizontal Valve



TECHNICAL DATA

TRIMPAC® MODEL E-3 FIRECYCLE® III MULTI-CYCLE WET

The Viking Corporation, 210 N Industrial Park Drive, Hastings MI 49058
 Telephone: 269-945-9501 Technical Services: 877-384-5464 Fax: 269-818-1680 Email: techsvcs@vikingcorp.com
 Visit the Viking website for the latest edition of this technical data page www.vikinggroupinc.com

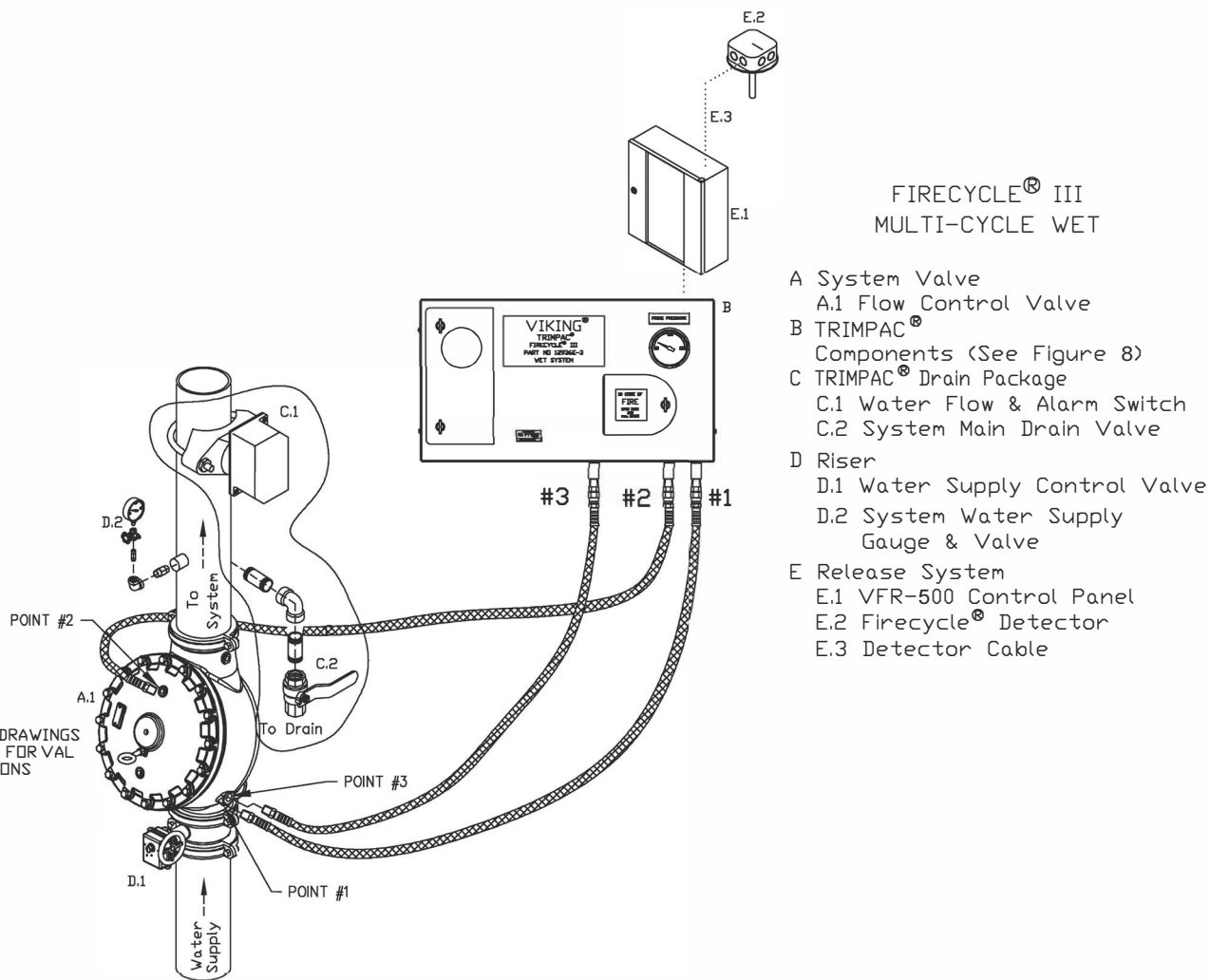

Figure 7
Firecycle® III Wet System
8" Straight-Through Vertical Valve



TECHNICAL DATA

TRIMPAC® MODEL E-3 FIRECYCLE® III MULTI-CYCLE WET

The Viking Corporation, 210 N Industrial Park Drive, Hastings MI 49058
 Telephone: 269-945-9501 Technical Services: 877-384-5464 Fax: 269-818-1680 Email: techsvcs@vikingcorp.com
 Visit the Viking website for the latest edition of this technical data page www.vikinggroupinc.com

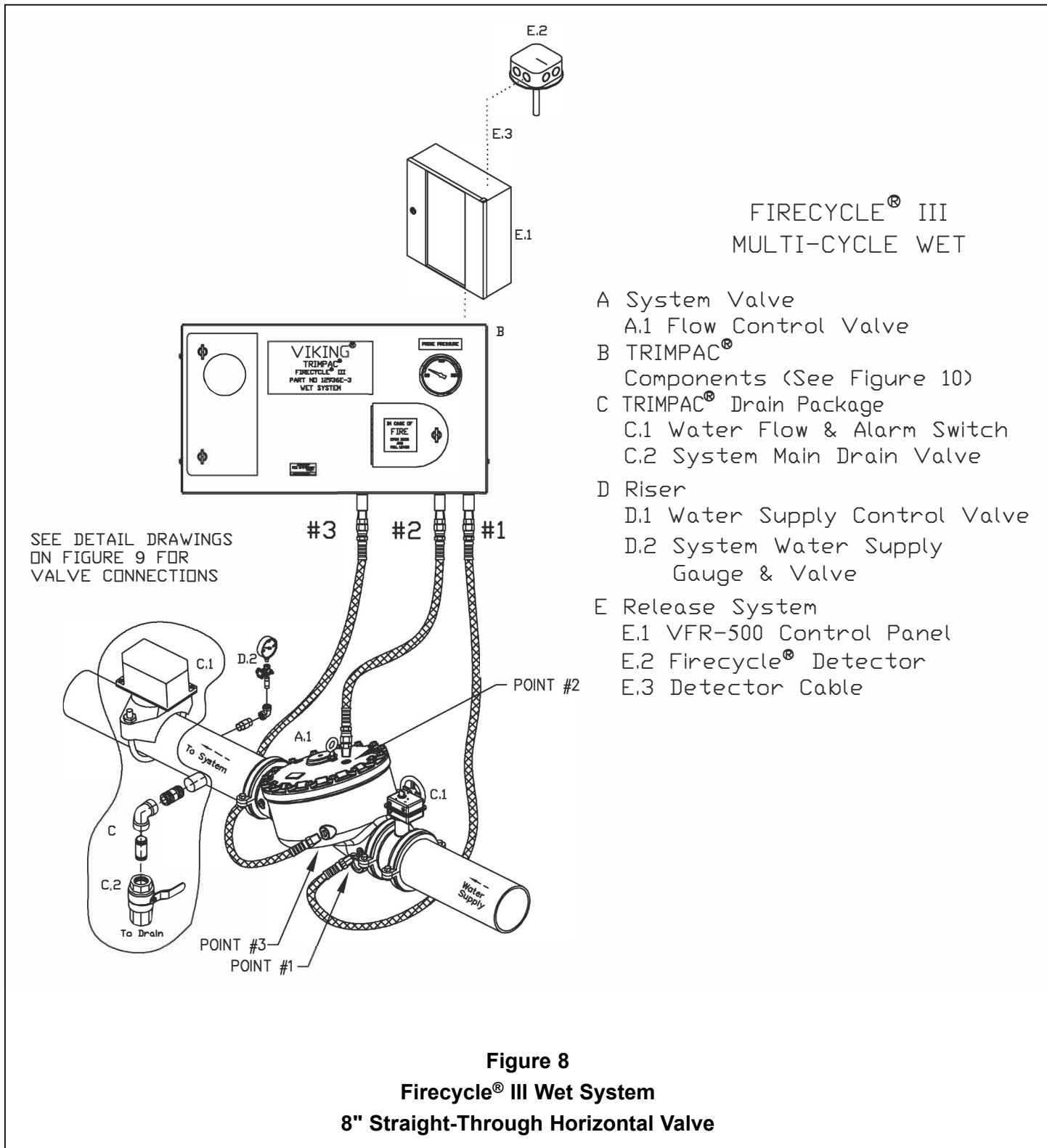



TECHNICAL DATA

TRIMPAC® MODEL E-3 FIRECYCLE® III MULTI-CYCLE WET

The Viking Corporation, 210 N Industrial Park Drive, Hastings MI 49058
 Telephone: 269-945-9501 Technical Services: 877-384-5464 Fax: 269-818-1680 Email: techsvcs@vikingcorp.com
 Visit the Viking website for the latest edition of this technical data page www.vikinggroupinc.com

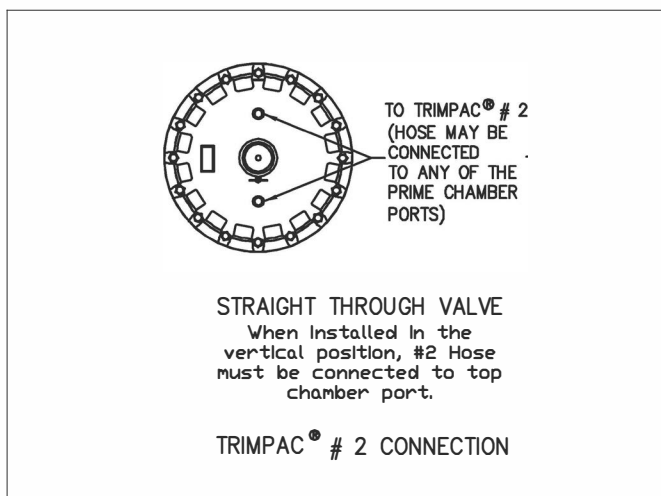
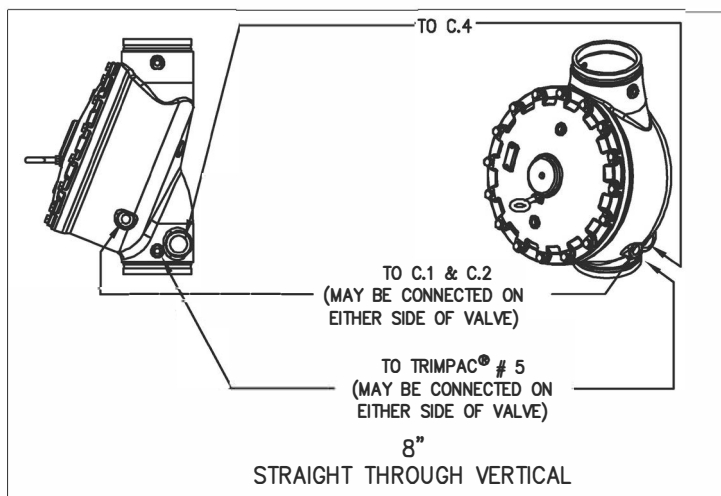
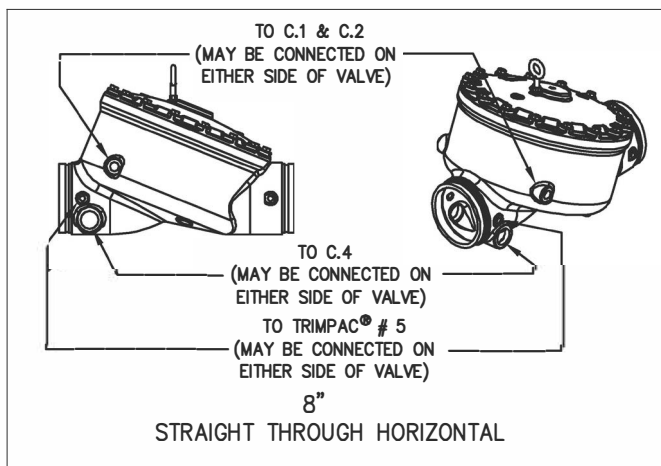
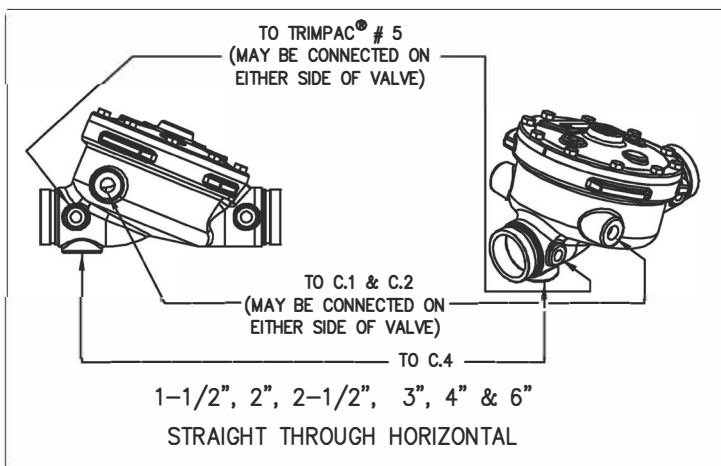
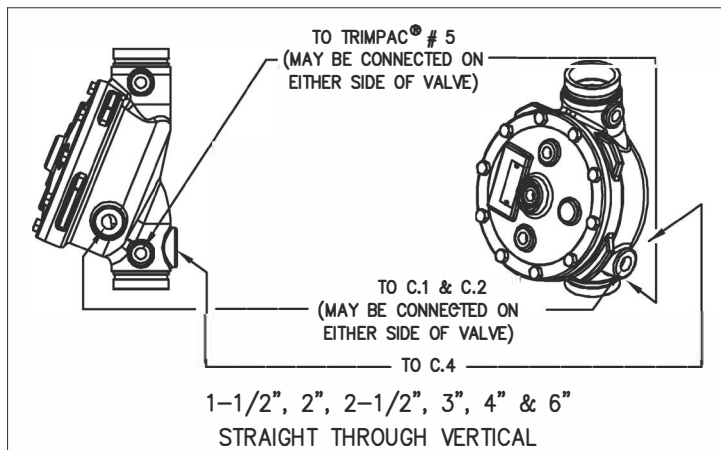

Figure 9 - Valve Connections



TECHNICAL DATA

**TRIMPAC® MODEL E-3
FIRECYCLE® III MULTI-CYCLE WET**

The Viking Corporation, 210 N Industrial Park Drive, Hastings MI 49058

Telephone: 269-945-9501 Technical Services: 877-384-5464 Fax: 269-818-1680 Email: techsvcs@vikingcorp.com

Visit the Viking website for the latest edition of this technical data page www.vikinggroupinc.com

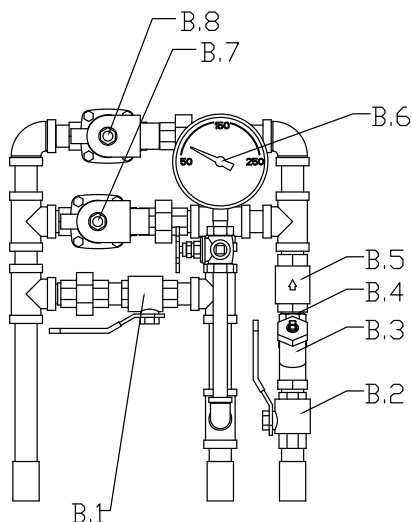

- B. TRIMPAC, FIRECYCLE III Wet
- B.1 Emergency Release (Normally Closed)
 - B.2 Priming Valve (Normally Open)
 - B.3 Strainer
 - B.4 1/8" Restriction
 - B.5 Spring Loaded Check Valve
 - B.6 Priming Pressure Water Gauge and Valve
 - B.7 Solenoid Valve (Normally Closed)
 - B.8 Solenoid Valve (Normally Open)

Figure 10 - TRIMPAC® Components (Items B.1 - B.8)

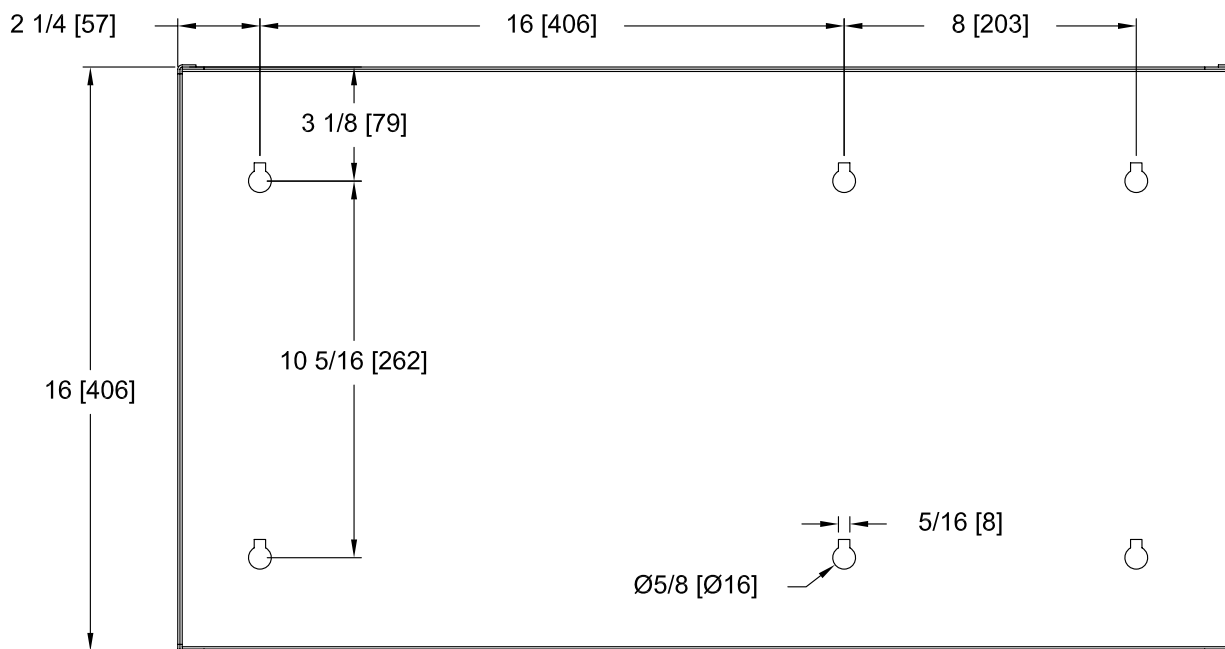

Figure 11 - Mounting Dimensions

Wall Mounting Notes:

1. Mounting Fasteners are supplied by the contractor.
2. Recommended Fasteners - Minimum 1/4" x 1-1/2 Lg. Hex Head lag screws with washers.
3. When installing into concrete, drywall or metal, use typical grommet.
4. Approximate Weight of TRIMPAC® Model B-3 and Flexible Hoses: 40 lbs. (31.3 kg)