



TECHNICAL DATA

TRIMPAC® MODEL D-2 & D-2B SUREFIRE® DOUBLE INTERLOCK PREACTION

The Viking Corporation, 210 N Industrial Park Drive, Hastings MI 49058

Telephone: 269-945-9501 Technical Services: 877-384-5464 Fax: 269-818-1680 Email: techsvcs@vikingcorp.com

1. DESCRIPTION

The Viking Double SUREFIRE® Single Interlock Preaction TRIMPAC® Model D-2 and D-2B used with either a Model E or F Deluge Valve (A.1), a Viking Easy Riser Check Valve (F.1) or VFR-500 Release Control Panel (G.1) and all associated trim piping form a unique operating system. The system piping is normally dry and pneumatically pressurized to supervise the integrity of the piping, fitting and sprinklers and provide the failsafe operation of the system upon loss of the primary and secondary power supplies. Double Interlock Preaction systems are commonly used in areas subject to freezing and to help minimize accidental water damage.

The Viking SUREFIRE® Double Interlock Preaction TRIMPAC® Model D-2 & D-2B is a factory assembled and tested unit. The enclosure incorporates access doors for the emergency release and alarm test valves and view ports for the prime and water supply pressure gauges. The TRIMPAC® Model D-2 and D-2B eliminates the field assembly of the deluge valve trim and release module piping. The enclosure protects the trim from damage or inadvertent operation. The included stainless steel hoses (or field provided piping) from the deluge valve to the enclosure assembly allows the TRIMPAC® Model D-2 & D-2B to be installed remote from the sprinkler system riser. A valve drain package is required for the deluge valve and is ordered based on the size of the deluge valve. See Figures 12-13 for drain trim charts.

Note: Viking SUREFIRE® Double Interlock Preaction TRIMPAC® D-2 & D-2B is a complete system, and is listed as a unit. As such, it is normally not possible to modify the components of the system or their interrelationship without comprising the listing.



WARNING: Cancer and Reproductive Harm
www.P65Warnings.ca.gov

2. LISTINGS AND APPROVALS

 **cULus listed** - VLTR & VLTR7



FM Approved - Preaction Sprinkler Systems

3. TECHNICAL DATA

Specifications:

Rated Water Working Pressure: 250 psi (17.2 bar)

Gauges: 0-300 PSI (20.7 bar)

Weight: 55 lbs. (24.9 kg.)

Dimensions: 16-1/8" (409 mm) high x 29-1/8" (748 mm) wide x 8-25/32" (223 mm) deep

Material Standards:

Enclosure: 16 gauge steel, painted red: Epoxy Powder Coat

Gauges: Brass, 1/4 NPT, Plastic Body

Solenoid Valves (1 NC, 1 NO):

- Monitored Solenoid (NC): Brass body, 24 VDC, 5-300 PSI (0.34-20.7 bar), NEMA Rated 2, 3, 3S, 4, 4X, 9.0 Watts
- Non-Monitored Solenoid (NO): Brass Body 1/2" (1.27 cm), 24 Volt DC, 250 psi (17.2 bar) NEMA Rated 1, 2, 3, 3S, 4 or 4X, 9 Watts

PORV: Brass Body, 250 PSI (17.2 bar), 1/2" NPT inlet, 1/2" NTP drain, 1/2" NPT sensing side

Ball Valves: 1/2" NPT female ends

Strainer: Brass Body, 1/2" NPT inlet and outlet, 50 mesh stainless steel screen

Restricted Orifice: Brass Body, 1/2" NPT male inlet and outlet, 0.0625" orifice

Spring Loaded Check Valve: Brass Body, 1/2" NPT female inlet and outlet

Drain Check Valve: Brass Body, 1/2" NPT female inlet and outlet, EPDM clapper rubber

Hoses (4): Flexible braided stainless steel hoses with steel fittings and connectors, PTFE lined

Drain Hose (1): PVC Hose 60" long with brass hose connector x 1/2" NPT

Trim Piping: 1/2" galvanized or 1/2" brass

Fittings: 1/2" galvanized or 1/2" brass

Ordering Information: Refer to Table 1

Accessories:

1. Vertical Mounting Plate Kit - Part No. 11900
2. Horizontal Mounting Plate Kit - Part No. 11901
3. Hose Assembly Kit (Includes (4) Stainless Steel Hoses and (1) PVC Drain Hose) - Part No. 12072
4. Individual 5'-0" Stainless Steel & PTFE Hose: Part No. 16558 (4) (included with Part Nos. 13799D-2 and 13799D-2B)
5. Individual PVC Hose: P/N 12071 (1) (included with Part Nos. 13799D-2 and 13799D-2B)



TECHNICAL DATA

TRIMPAC® MODEL D-2 & D-2B SUREFIRE® DOUBLE INTERLOCK PREACTION

The Viking Corporation, 210 N Industrial Park Drive, Hastings MI 49058

Telephone: 269-945-9501 Technical Services: 877-384-5464 Fax: 269-818-1680 Email: techsvcs@vikingcorp.com

4. INSTALLATION (Refer to Figures 3-10 for identification of trim components. Refer to Figure 11 for wall-mounting.)

1. TRIMPAC® Model D-2 & D-2B SureFire® Double Interlock Trim Assemblies may be installed with Viking Model F (straight-through style) Deluge Valves, sizes 1-1/2", 2", 2-1/2", 3", 4", 6", and 8".
2. The TRIMPAC® Model D-2 & D-2B and valve must be installed in an area not subject to freezing.
3. The TRIMPAC® Model D-2 & D-2B must be installed to facilitate drainage.
4. The TRIMPAC® Model D-2 & D-2B must be installed above the elevation of the drip check valve (C.2).
5. The TRIMPAC® Model D-2 & D-2B can be installed with the hose package or 1/2" non-corrosive metallic piping. The maximum distance the TRIMPAC® Model D-2 & D-2B may be installed away from the deluge valve is 5'-0".
6. The check valve in the air line must be installed on the riser valve to facilitate drainage.
7. The deluge valve equipped with TRIMPAC® Model D-2 & D-2B must be installed in accordance with Viking Technical data. The required drain package must be installed in accordance with Figures 12 and 13.
 - a. Remove all plastic thread protectors from the openings of the deluge valve and the TRIMPAC® trim assembly.
 - b. Apply a small amount of pipe-joint compound or tape to the external threads of all pipe connections required. Take care not to allow any compound, tape, or other foreign matter inside any of the nipples or openings of the valve or trim components.
 - c. Verify that all system components are rated for the water working pressure of the system.

Hydrostatic Test:

The Viking deluge valve is manufactured and listed for use at a maximum Water Working Pressure of 250 PSI (17.2 bar). The valve is factory tested at 500 psi (34.5 bar). The Viking deluge valve may be hydrostatically tested at 300 PSI (20.7 bar) and/or 50 PSI (3.5 bar) above the normal Water Working Pressure, for limited periods of time (2 hours) for the purpose of acceptance by the Authority Having Jurisdiction. If air testing is required, do not exceed 40 psi (2.8 bar) air pressure.

Trim Note: (Refer also to System Data and/or Trim Chart.)

Discharge piping from the auxiliary drain valve (C.1), the flow test valve (C.4), and all system drains should be kept separate. DO NOT connect the outlet of the drip check (C.2) to any other drain.

CAUTION

Operation of Viking flow control valve by pressurizing the priming chamber with air pressure or any other pressurized gas is not recommended or approved.

8. Placing the System in Service: (Refer to Figures 3-10.)

NOTE: REFER TO THE VFR-500 OWNER'S MANUAL, AND INSTRUCTIONS PROVIDED IN TECHNICAL DATA DESCRIBING THE VIKING DELUGE VALVE AND OTHER SYSTEM COMPONENTS.

- a. Verify that the VFR-500 Control Panel (G.1), Detector Circuits and Detectors have been properly installed and energized according to instructions provided in Viking Technical Data and the release control panel Owner's Manual.
- b. Verify that the system has been properly drained. (When plunger is depressed on drip check (C.2), no water should flow.) System Drain should be open. Verify that Emergency Release (B.1) is closed. **Note:** Emergency release (B.1) is closed when the handle is In-Line with the pipe. This allows the door to close when the valve is in the normal position.
- c. Verify that the System Main Water Supply Control Valve (E.1) is closed and the Deluge Valve (A.1) is trimmed according to Figures 3 through 12.
- d. Verify that the system water supply piping is pressurized up to the closed System Main Water Supply Control Valve (E.1) and the priming line is pressurized up to the closed Priming Valve (B.2).
- e. Establish a normal condition on the VFR-500 Control Panel (G.1): Open panel and press "RESET". Release Solenoid Valve (B.14) should close. Flow from Release Solenoid Valve (B.14) to Drain Cup (C.3) should stop.
- f. Establish system air pressure. Make sure Supervisory Air Switch (B.18) is set to proper activation pressure.
- g. Open Priming Valve (B.2).
- h. Open Flow Test Valve (C.4).
- i. Partially open Main Water Supply Control Valve (E.1) (if closed).
- j. When full flow develops from Flow Test Valve (C.4), close the Flow Test Valve. Verify that there is no flow from open Auxiliary Drain (C.1).
- k. Close Auxiliary Drain (C.1).
- l. Fully open and secure the Main Water Supply Control Valve (E.1).
- m. Verify that the Alarm Shut-off Valve (B.10) is open and that all other valves are in their normal operating position.
- n. Depress the plunger of the Drip Check (C.2). No water should flow from the Drip Check when the plunger is pushed.



TECHNICAL DATA

TRIMPAC® MODEL D-2 & D-2B SUREFIRE® DOUBLE INTERLOCK PREACTION

The Viking Corporation, 210 N Industrial Park Drive, Hastings MI 49058

Telephone: 269-945-9501 Technical Services: 877-384-5464 Fax: 269-818-1680 Email: techsvcs@vikingcorp.com

5. OPERATION (Refer to Figures 3-10.)

In the SET condition:

System water supply pressure enters the priming chamber of the Deluge Valve (A.1) through the 1/4" (8 mm) hose and 1/2" priming line which includes a normally open priming valve (B.2), strainer (B.3), restricted orifice (B.4) and check valve (B.5). In the SET condition, water supply pressure is trapped in the priming chamber by check valve (B.5), normally closed Emergency Release (B.1), Pneumatic Actuator (B.12), Pressure Operated Relief Valve (PORV) (B.11) and normally closed Release Solenoid Valve (B.14). Water Supply pressure in the priming chamber holds the clapper of the Deluge Valve (A.1) on the seat due to the differential design of the valve pressure. The clapper separates the inlet chamber from the outlet chamber, keeping the outlet chamber and system piping dry.

In Fire Conditions:

When the detection system (G.2) operates, the VFR-500 Control Panel (G.1) activates the system alarm and initiates the appropriate detection alarms. No water enters the system piping at this time. When a sprinkler operates, as caused by the heat of a fire, system supervisory air is lost, and the Low Air Pressure Switch (B.18) is activated. Only after both indicating circuits have operated, the VFR-500 Release Control Panel (G.1) energizes normally closed Release Solenoid Valve (B.14) open and normally open Release Solenoid Valve (B.17) closed. Pressure is released from the priming chamber faster than it is supplied through restricted orifice (B.4). The Deluge Valve (A.1) clapper opens to allow water flow into the system piping and to alarm devices. Water entering the system piping increases pressure on the PORV (B.11), which vents off the water supply to the priming chamber. Water will flow from any open sprinklers or nozzles.

To return the system to "Normal" conditions, drain the system piping and replace any sprinklers that may have operated. Replace any detectors which have been damaged. Re-establish system air pressure by following the steps in section 4. INSTALLATION, Step 8 Placing the System in Service.

Panel Trouble, Loss of Power Prior to Operation or Pipe Damage Conditions: During Normal Power Supply Conditions, faults or complete loss of power.

During normal power conditions if the system piping and/or the sprinklers are damaged, the low pressure supervisory switch (B.18) will activate a supervisory alarm at the PAR-3 or VFR-500 Release Control Panel (G.1) and the normally open solenoid valve (B.17) will be powered closed to prevent the deluge valve from opening.

In the event of a fire during a fault on the input circuit wiring, loss of primary AC power or complete loss of all power, the deluge valve will open allowing water flow if the following conditions occur:

1. The initiating devices (G.2) activate causing the VFR-500 Release Control Panel (G.1) to enter an alarm and release condition. The normally closed solenoid (E.14) will open allowing water pressure to be relieved from the priming chamber of the deluge valve (A.1). With pressure relieved from the priming chamber, the deluge valve will open and allow water flow. Water will not be discharged into the protected area until a sprinkler head operates.
2. During a fault condition on the input wiring which caused a trouble alarm on the VFR-500 Release Control Panel (G.1) or a complete loss of normal AC power and standby battery backup power, the normally open solenoid (B.17) is prevented from operating. During this condition, activation of a sprinkler head will allow a pneumatic release of the deluge valve (A.1). Water pressure will be relieved from the priming chamber, the deluge valve (A.1) will open and allow water to flow.

Loss of Power During Operation:

If all power fails while the system is flowing water, the normally open Release Solenoid (B.17) will open and the normally closed Release Solenoid (B.14) will remain closed. The PORV (B.11) is already pressurized open to prevent pressure in the chamber from building up. Water from main supply will continue entering the system, and through any open sprinkler(s).

6. INSPECTIONS, TESTS AND MAINTENANCE

It is imperative that the system be inspected and tested on a regular basis. The frequency of the inspections may vary due to contaminated water supplies, corrosive water supplies, or corrosive atmospheres. Also, the alarm devices, detection systems, or other connected trim may require a more frequent schedule. For minimum maintenance and inspection requirements, refer to NFPA 25. In addition, the Authority Having Jurisdiction may have additional maintenance, testing, and inspection requirements that must be followed. Refer to the specific Viking deluge valve data page for periodic testing.

Maintenance:

TRIMPAC® Model D-2 should be inspected, tested, and maintained in accordance with the latest edition of NFPA 25, The Standard for Inspection, Testing, and Maintenance of water based fire protection systems, and in accordance with the Authority Having Jurisdiction.



TECHNICAL DATA

TRIMPAC® MODEL D-2 & D-2B
SUREFIRE® DOUBLE
INTERLOCK PREACTION

The Viking Corporation, 210 N Industrial Park Drive, Hastings MI 49058

Telephone: 269-945-9501 Technical Services: 877-384-5464 Fax: 269-818-1680 Email: techsvcs@vikingcorp.com

NOTICE

The owner is responsible for maintaining the fire protection system and devices in proper operating condition. The flow control valve must be kept from freezing conditions and physical damage that could impair its operation. Contact the valve manufacturer or authorized representative when performance difficulty occurs and field adjustment is needed.

WARNING

Any system maintenance that involves placing a control valve or detection system out of service may eliminate the fire protection capabilities of that system. Prior to proceeding, notify all Authorities Having Jurisdiction. Consideration should be given to employment of a fire patrol in the affected areas.

After Each Operation:

1. Sprinkler systems that have been subjected to a fire must be returned to service as soon as possible. The entire system must be inspected for damage, and repaired or replaced as necessary.
2. Deluge valves and TRIMPAC® Model D-2 that have been subjected to brackish water, salt water, foam, foam/water solution, or any other corrosive water supply should be flushed with good quality fresh water before being returned to service. Refer to specific deluge valve for a maintenance schedule.

7. AVAILABILITY

The Viking TRIMPAC® Model D-2 is available through a network of domestic and international distributors. See the Viking Corp. Web site for closest distributor or contact The Viking Corporation.

8. GUARANTEE

For details of warranty, refer to Viking's current list price schedule or contact Viking directly.

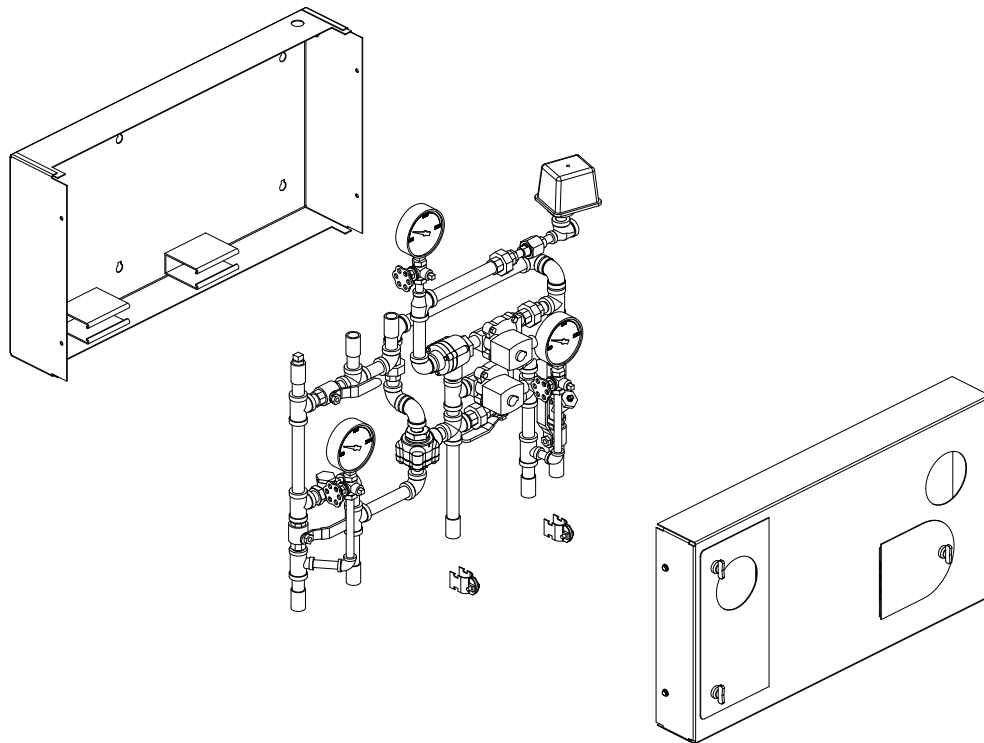

Figure 1: Isometric View



TECHNICAL DATA

**TRIMPAC® MODEL D-2 & D-2B
SUREFIRE® DOUBLE
INTERLOCK PREACTION**

The Viking Corporation, 210 N Industrial Park Drive, Hastings MI 49058
 Telephone: 269-945-9501 Technical Services: 877-384-5464 Fax: 269-818-1680 Email: techsvcs@vikingcorp.com

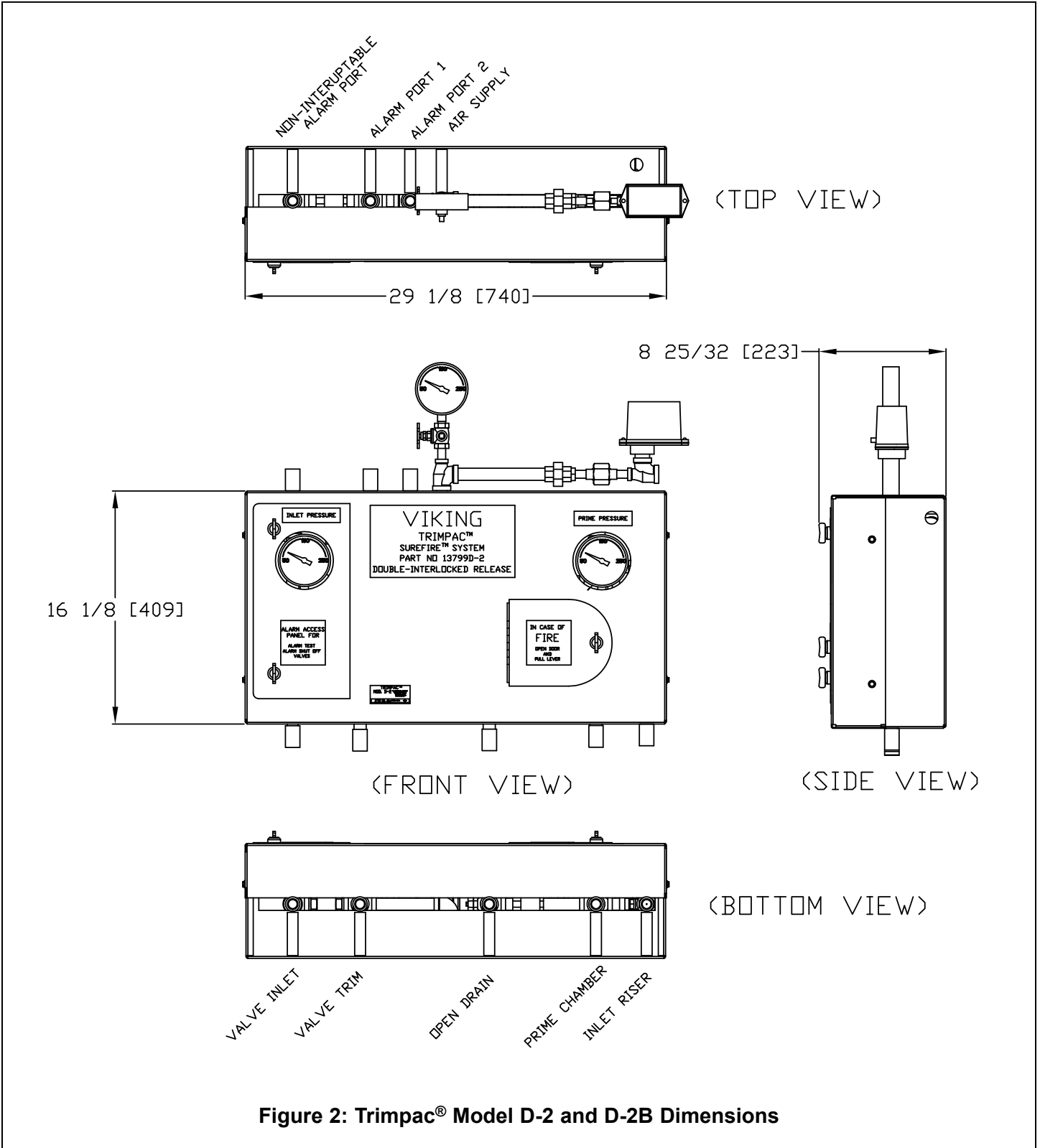

Figure 2: Trimpac® Model D-2 and D-2B Dimensions



TECHNICAL DATA

**TRIMPAC® MODEL D-2 & D-2B
SUREFIRE® DOUBLE
INTERLOCK PREACTION**

The Viking Corporation, 210 N Industrial Park Drive, Hastings MI 49058

Telephone: 269-945-9501 Technical Services: 877-384-5464 Fax: 269-818-1680 Email: techsvcs@vikingcorp.com

Ordering Information

Component	Description	Part Numbers	Corresponding Data Pages																
System Valve																			
A	A.1	Deluge Valve	Various																
			F_040104, F_110802, F_040204, F_110902																
B	Trimpac®		13799D-2	--															
			13799D-2B (Brass available by special order only)																
			28232D-2*																
			28232D-2B*																
*Note: Monitored solenoid option: Each of the above configurations can be ordered with a monitored or non-monitored release solenoid. The monitored solenoid is a new option, which offers an NFPA 13 solenoid monitoring-compliant solution.																			
B.1 - B.18	Trimpac® Components	Refer to Figure 10.																	
Trimpac® Drain Package																			
C	C.1	Auxiliary Drain Valve (NC)	<table style="width: 100%; border: none;"> <thead> <tr> <th></th> <th style="text-align: center;">Galv.</th> <th style="text-align: center;">Brass</th> </tr> </thead> <tbody> <tr> <td>1-1/2" -</td> <td style="text-align: center;">11894-1 or 11894-5</td> <td></td> </tr> <tr> <td>2" -</td> <td style="text-align: center;">11894-2 or 11894-6</td> <td></td> </tr> <tr> <td>2-1/2" & 3" -</td> <td style="text-align: center;">11894-3 or 11894-7</td> <td></td> </tr> <tr> <td>4", 6", & 8" -</td> <td style="text-align: center;">11894-4 or 11894-8</td> <td></td> </tr> </tbody> </table>		Galv.	Brass	1-1/2" -	11894-1 or 11894-5		2" -	11894-2 or 11894-6		2-1/2" & 3" -	11894-3 or 11894-7		4", 6", & 8" -	11894-4 or 11894-8		--
		Galv.		Brass															
	1-1/2" -	11894-1 or 11894-5																	
	2" -	11894-2 or 11894-6																	
2-1/2" & 3" -	11894-3 or 11894-7																		
4", 6", & 8" -	11894-4 or 11894-8																		
C.2	Drip Check Valve																		
C.3	Drain Cup																		
C.4	Flow Test Valve (NC)																		
Water Flow Alarm Equipment																			
D	D.1	Alarm Pressure Switch	PS101A	--															
	D.2	Water Motor Alarm (F-2) (Optional)	07862	F_082789															
	D.3	Strainer	01489A	--															
	D.4	Electric Alarm Bell	-	--															
Riser																			
E	E.1	Water Supply Control Valve	-	--															
Check Valve																			
F	F.1	1-1/2" & 2" - L-1 or M-1 Check Valve 3" - 8" - Easy Riser Check Valve	Various	--															
	F.2	Check Valve Trim	Various																
Release System																			
G	G.1	VFR-500 Multi-Hazard Release Control Panel	26107	F_081022															
	G.2	Electric Detection System	Various	--															
Air Supply																			
H	--	Air Line Trim for TANK Mounted Compressor	13770	--															
	--	Air Line Trim for RISER Mounted Compressor	13771	--															

Table 1: Trimpac® System Components
Refer to Figures 3 through 10 for Component Identification.





TECHNICAL DATA

TRIMPAC® MODEL D-2 & D-2B SUREFIRE® DOUBLE INTERLOCK PREACTION

The Viking Corporation, 210 N Industrial Park Drive, Hastings MI 49058

Telephone: 269-945-9501 Technical Services: 877-384-5464 Fax: 269-818-1680 Email: techsvcs@vikingcorp.com

Legend for Figures 3 - 8

- Dotted lines indicate electrical system wiring required but not listed in "System Components" Table. For additional wiring requirements refer to technical data for components used.
- Dashed lines indicate pipe required but not included with TRIMPAC trim packages. Minimum 1/2" nominal piping recommended.
-  Smaller diameter hoses are the (4) included flexible braided stainless steel hoses. Also available as a kit (P/N) 12072
-  Larger diameter hose is the included PVC Drain Hose. Also available separately (P/N 12071).
- ** 1/2" (15 mm) NPT for non-interruptible Alarm Pressure Switch (Optional)

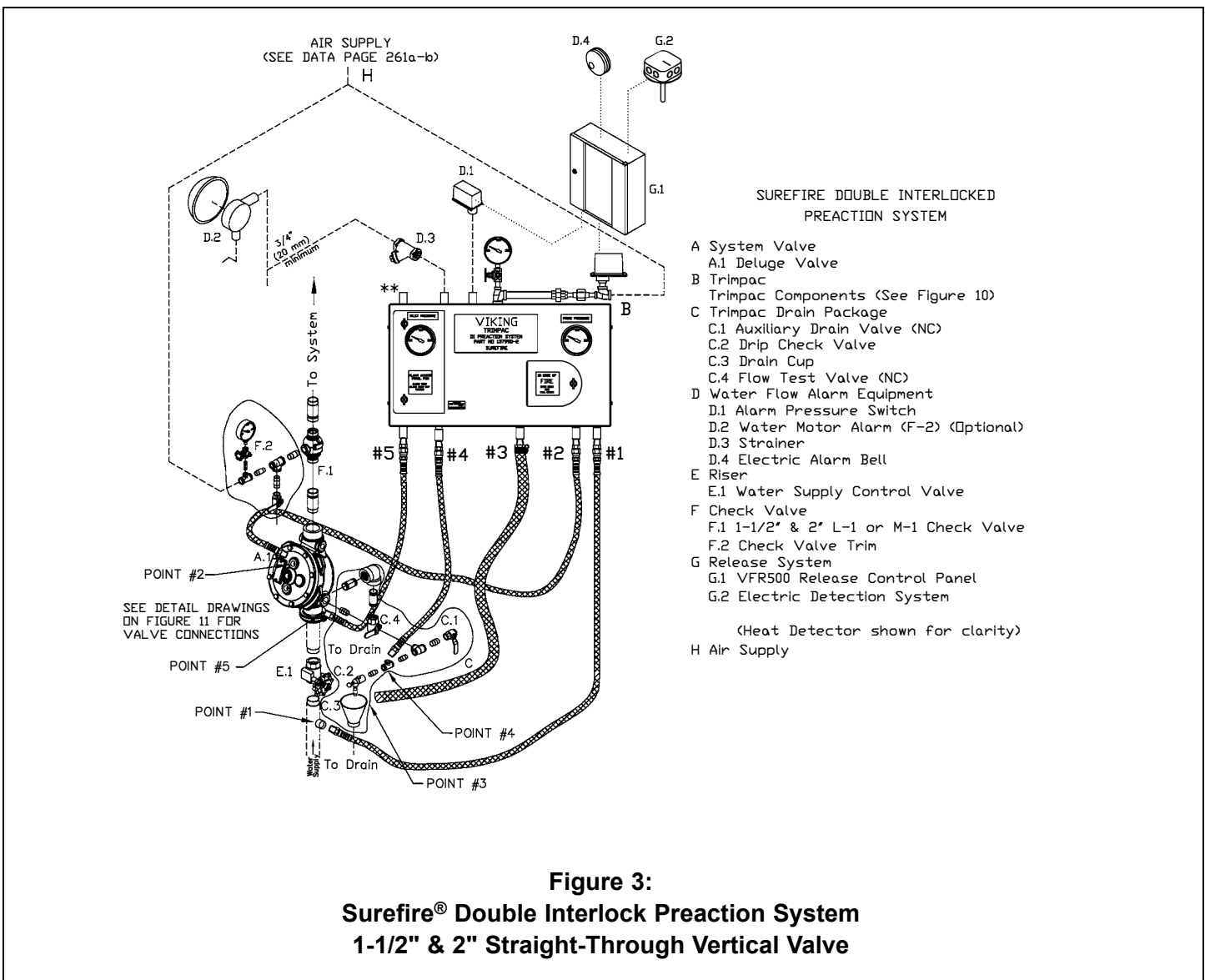



TECHNICAL DATA

TRIMPAC® MODEL D-2 & D-2B SUREFIRE® DOUBLE INTERLOCK PREACTION

The Viking Corporation, 210 N Industrial Park Drive, Hastings MI 49058

Telephone: 269-945-9501 Technical Services: 877-384-5464 Fax: 269-818-1680 Email: techsvcs@vikingcorp.com

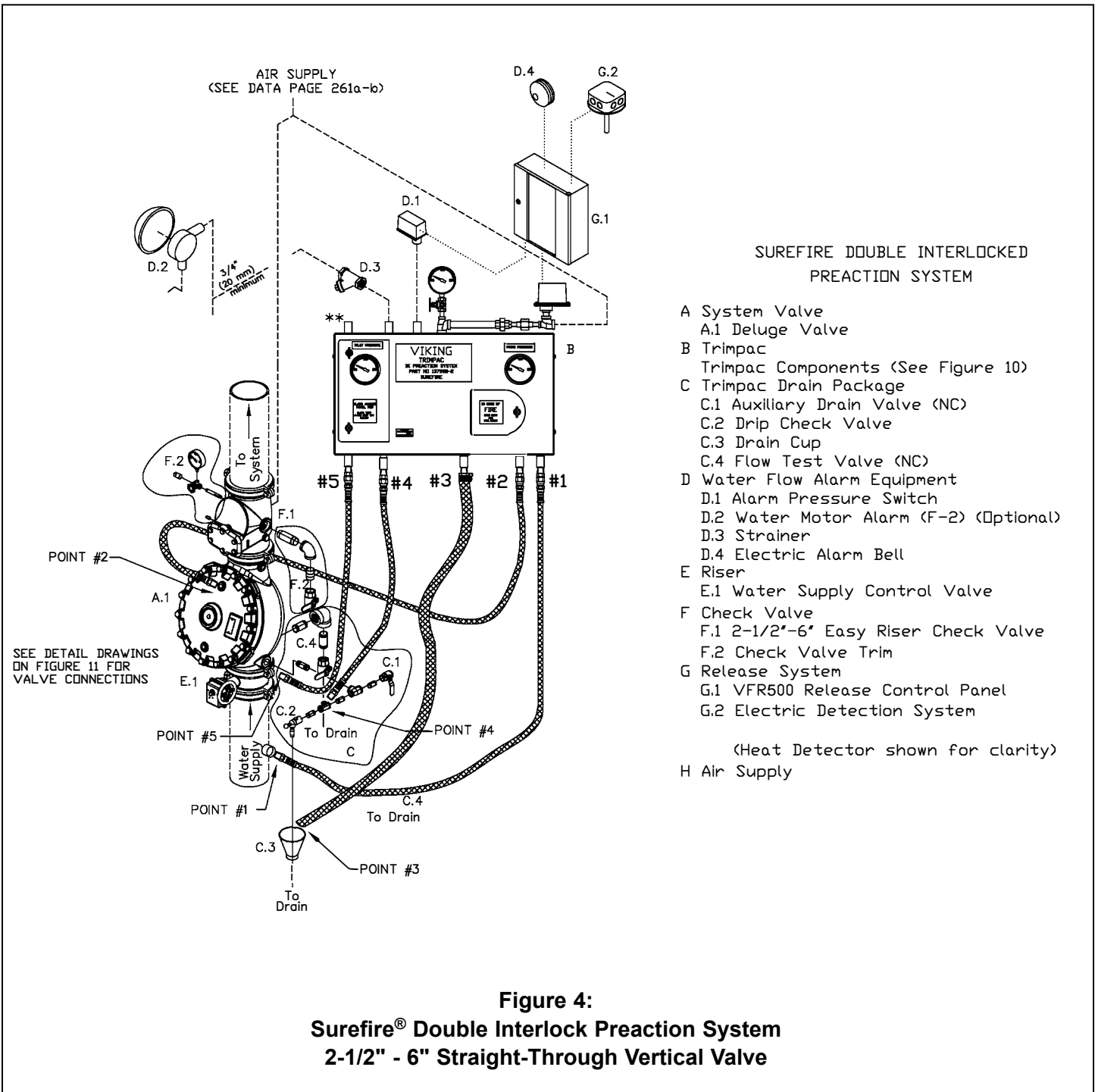



TECHNICAL DATA

TRIMPAC® MODEL D-2 & D-2B SUREFIRE® DOUBLE INTERLOCK PREACTION

The Viking Corporation, 210 N Industrial Park Drive, Hastings MI 49058

Telephone: 269-945-9501 Technical Services: 877-384-5464 Fax: 269-818-1680 Email: techsvcs@vikingcorp.com

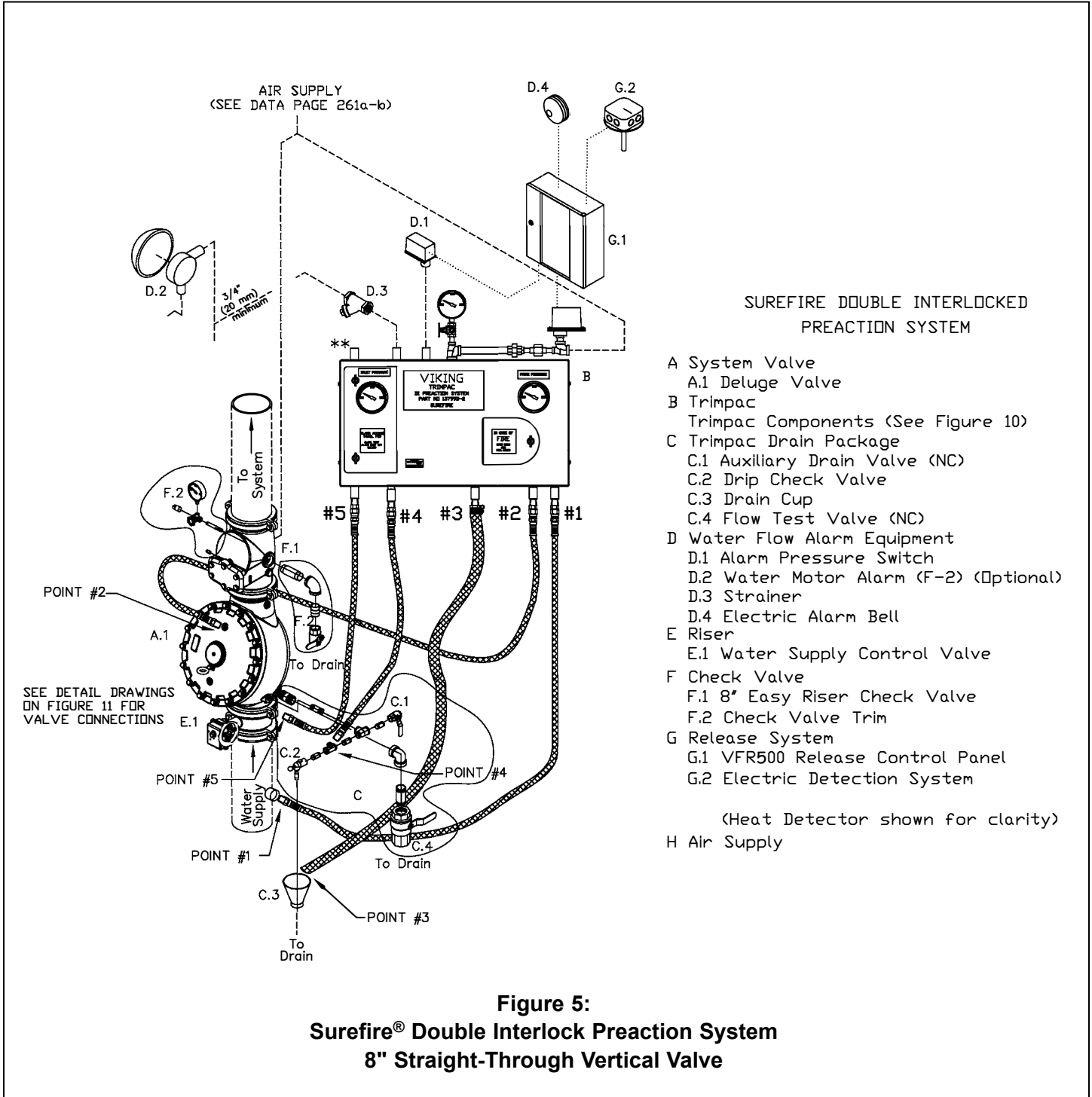



TECHNICAL DATA

TRIMPAC® MODEL D-2 & D-2B SUREFIRE® DOUBLE INTERLOCK PREACTION

The Viking Corporation, 210 N Industrial Park Drive, Hastings MI 49058

Telephone: 269-945-9501 Technical Services: 877-384-5464 Fax: 269-818-1680 Email: techsvcs@vikingcorp.com

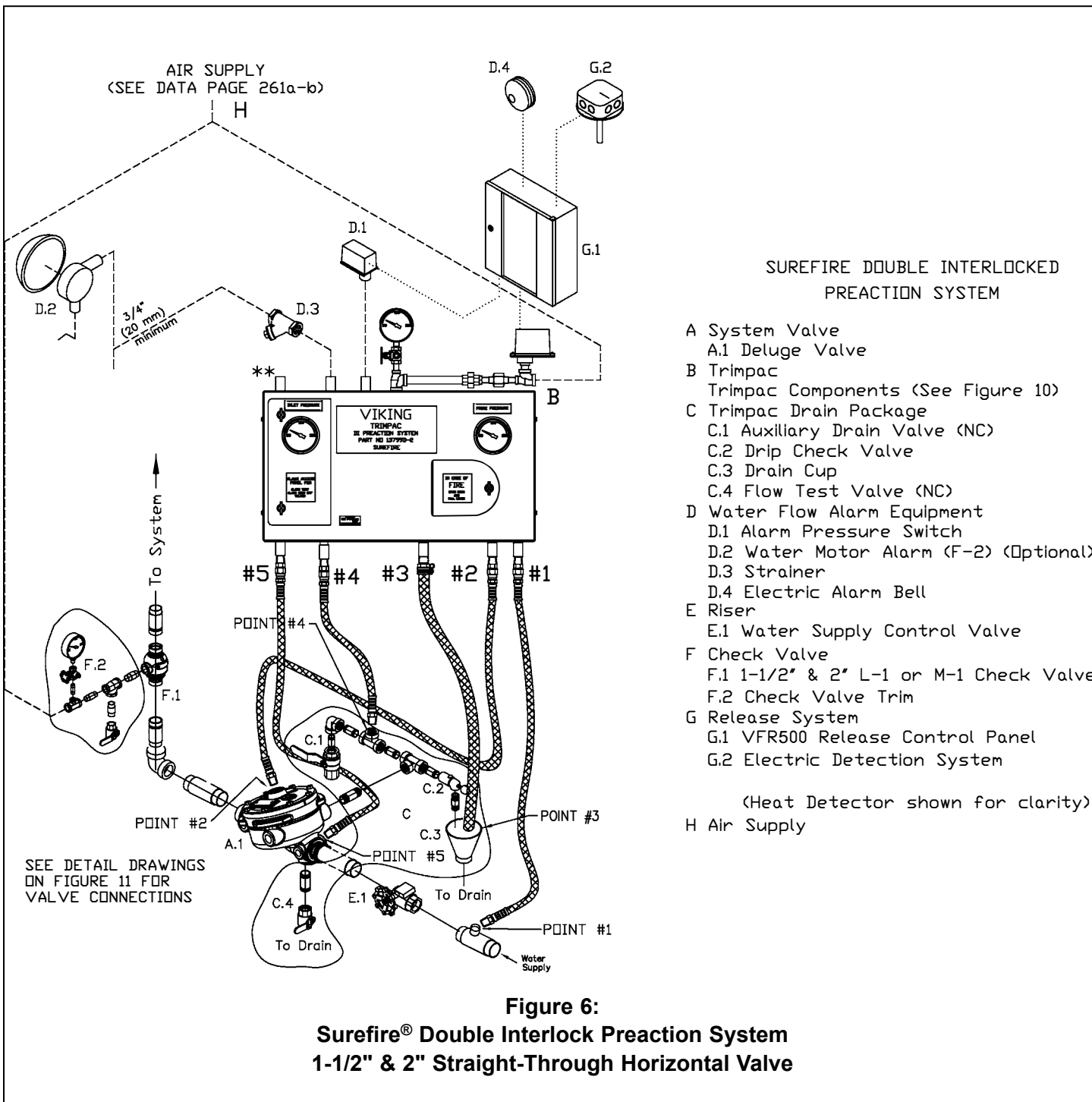



TECHNICAL DATA

TRIMPAC® MODEL D-2 & D-2B SUREFIRE® DOUBLE INTERLOCK PREACTION

The Viking Corporation, 210 N Industrial Park Drive, Hastings MI 49058

Telephone: 269-945-9501 Technical Services: 877-384-5464 Fax: 269-818-1680 Email: techsvcs@vikingcorp.com

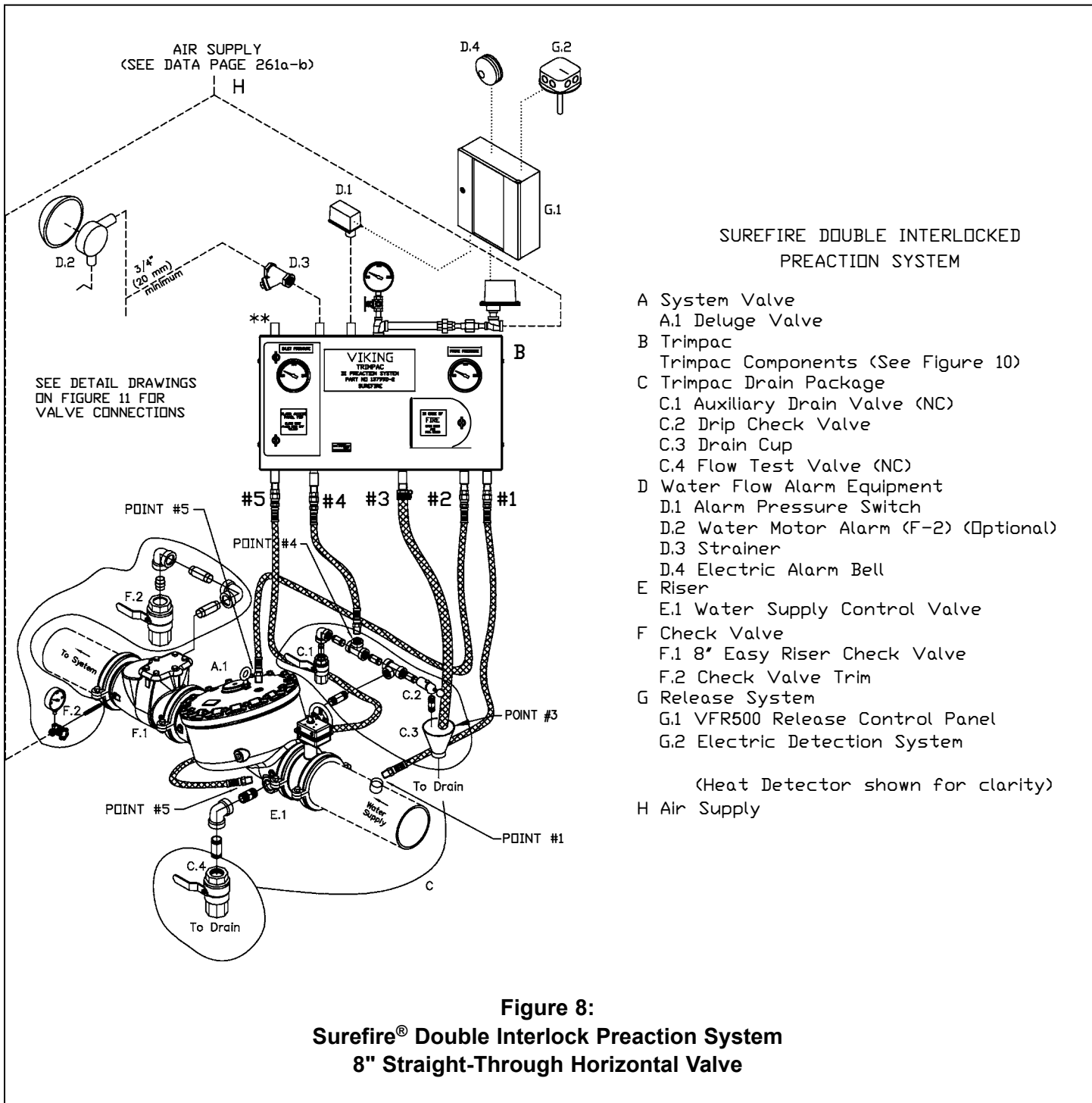



TECHNICAL DATA

**TRIMPAC® MODEL D-2 & D-2B
SUREFIRE® DOUBLE
INTERLOCK PREACTION**

The Viking Corporation, 210 N Industrial Park Drive, Hastings MI 49058

Telephone: 269-945-9501 Technical Services: 877-384-5464 Fax: 269-818-1680 Email: techsvcs@vikingcorp.com

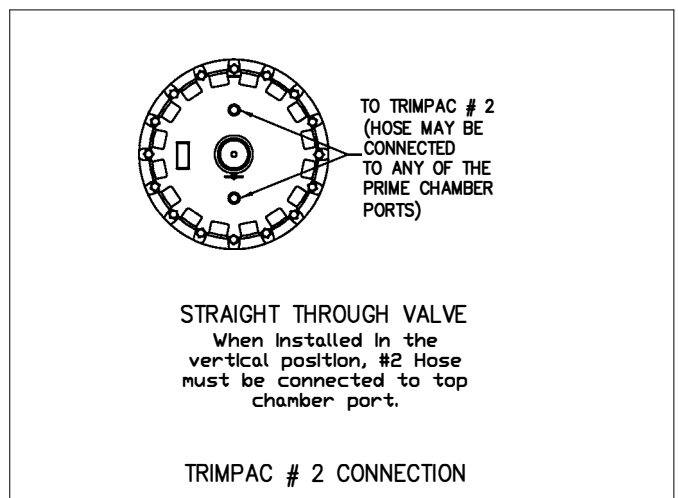
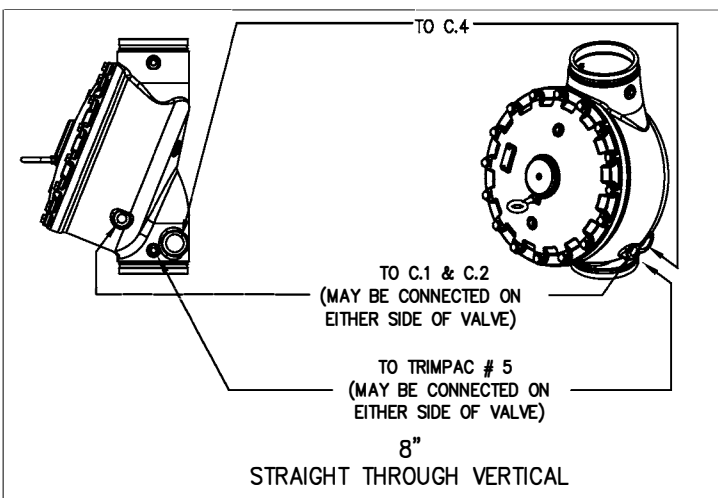
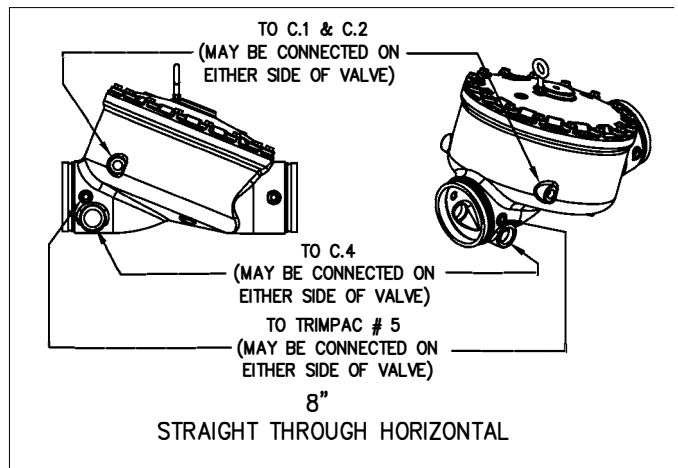
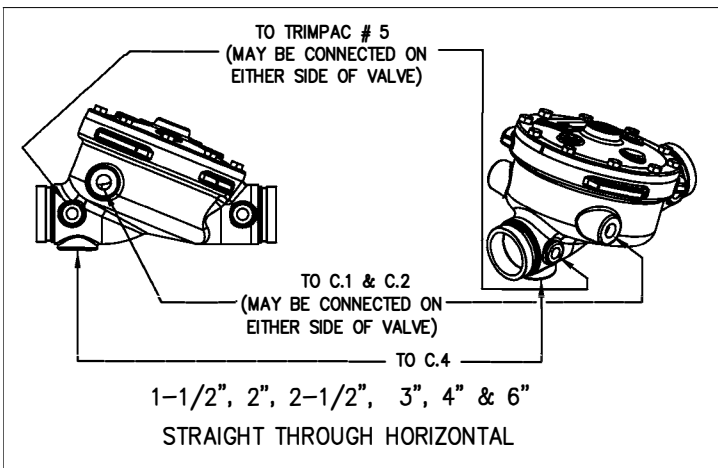
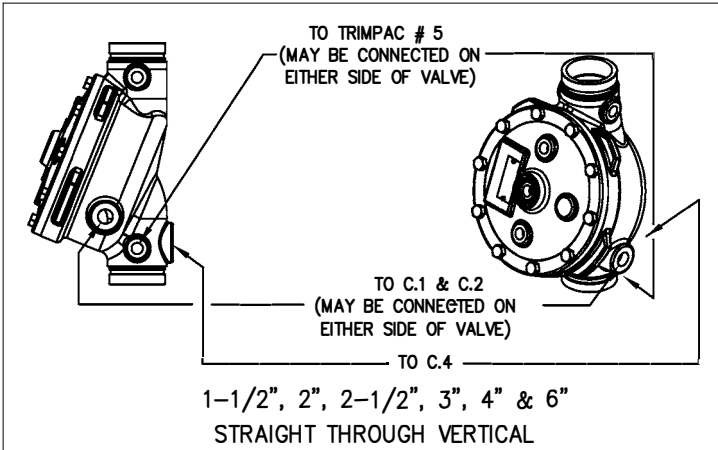

Figure 9: Valve Connections



TECHNICAL DATA

TRIMPAC® MODEL D-2 & D-2B SUREFIRE® DOUBLE INTERLOCK PREACTION

The Viking Corporation, 210 N Industrial Park Drive, Hastings MI 49058

Telephone: 269-945-9501 Technical Services: 877-384-5464 Fax: 269-818-1680 Email: techsvcs@vikingcorp.com

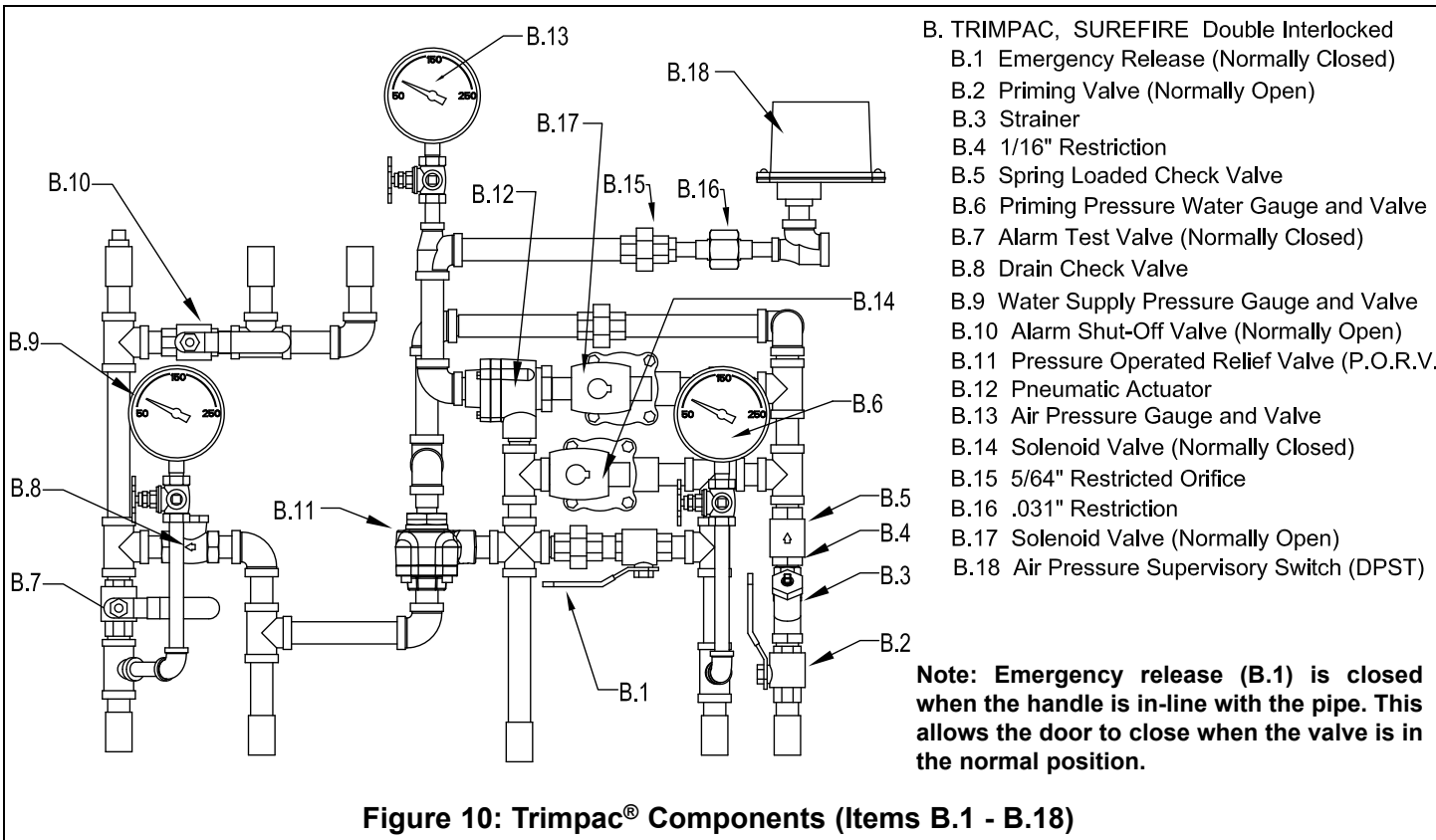
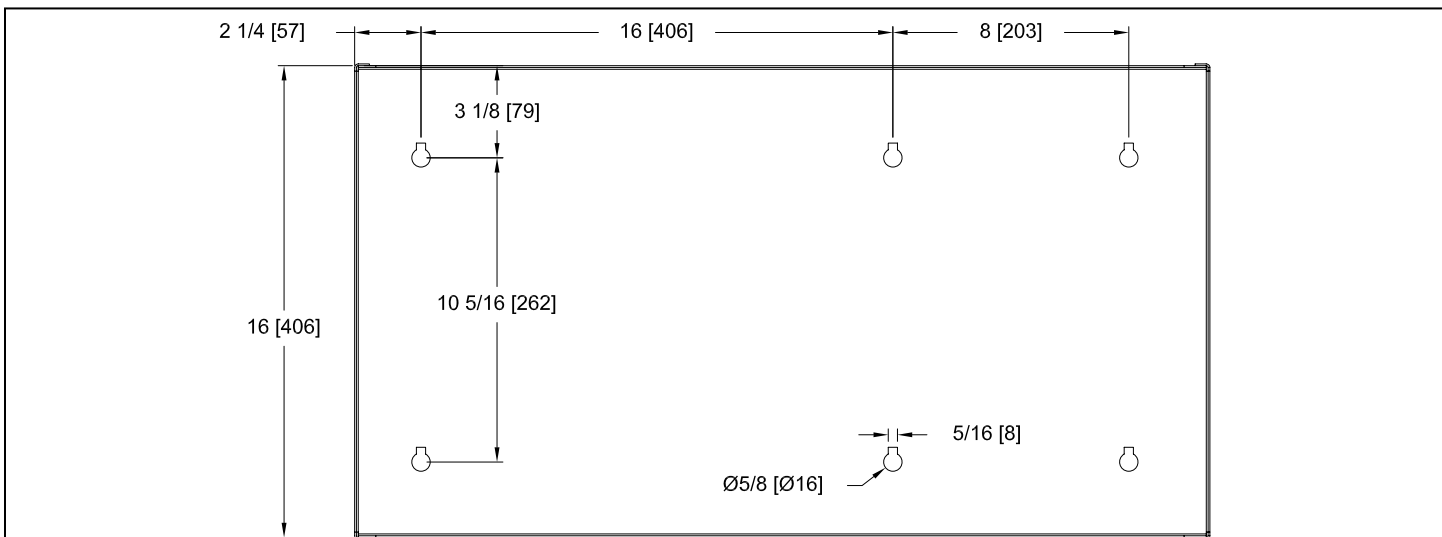

Figure 10: Trimpac® Components (Items B.1 - B.18)



Wall Mounting Notes:

1. Mounting Fasteners are supplied by the contractor.
2. Recommended Fasteners - Minimum 1/4" X 1-1/2 Lg. Hex Head lag screws with washers.
3. When installing into concrete, drywall or metal, use typical grommet.
4. Approximate Weight of Trimpac® Model D-2 and Flexible Hoses: 55 lbs. (24.9 kg)

Figure 11: Mounting Dimensions



TECHNICAL DATA

TRIMPAC® MODEL D-2 & D-2B SUREFIRE® DOUBLE INTERLOCK PREACTION

The Viking Corporation, 210 N Industrial Park Drive, Hastings MI 49058

Telephone: 269-945-9501 Technical Services: 877-384-5464 Fax: 269-818-1680 Email: techsvcs@vikingcorp.com

TRIMPAC® DRAIN PACKAGE PART NUMBERS			
Valve	Size	Galvanized	Brass
Straight	8" (DN200)	11894-4	11894-8

8" (DN200) Straight-Through Vertical Valve Drain Package Trim Chart

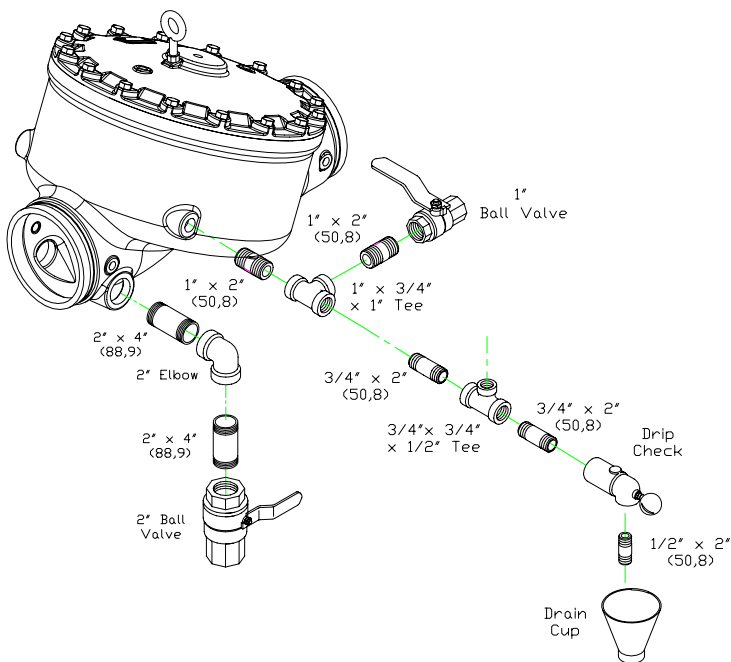
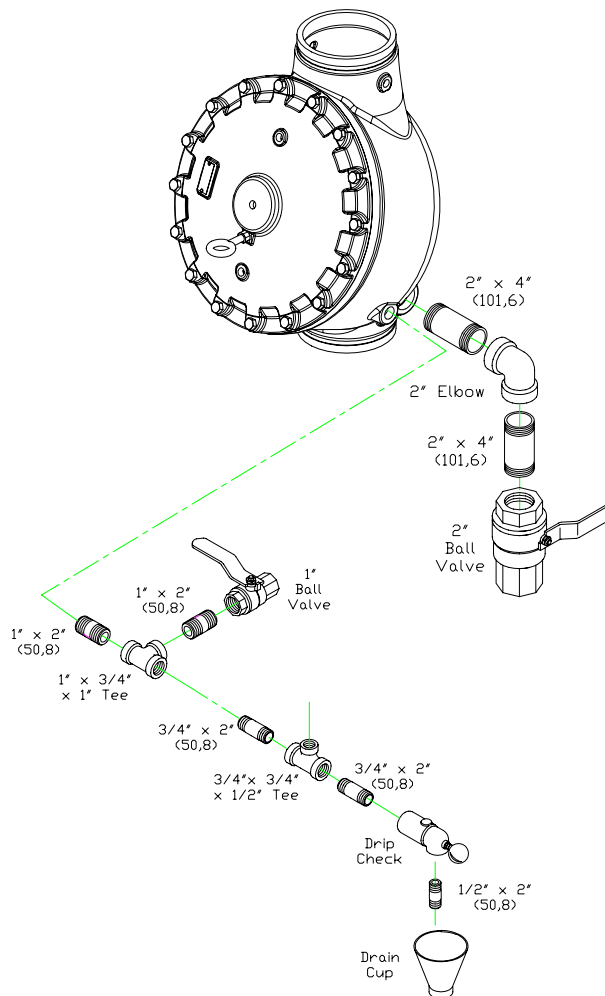

8" (DN200) Straight-Through Horizontal Valve Drain Package Trim Chart

Figure 13