



## TECHNICAL DATA

### SINGLE INTERLOCKED PREACTION SYSTEM WITH ELECTRIC RELEASE

The Viking Corporation, 210 N Industrial Park Drive, Hastings MI 49058

Telephone: 269-945-9501 | Technical Services: 877-384-5464 | Fax: 269-818-1680 | Email: techsvcs@vikingcorp.com

Visit the Viking website for the latest edition of this technical data page [www.vikinggroupinc.com](http://www.vikinggroupinc.com)

## 1. DESCRIPTION

(Refer to Figures 1-7.)

Viking supervised Single-Interlocked Preaction Systems utilize a Viking Deluge Valve and a pneumatically pressurized automatic sprinkler system. The system piping is pneumatically pressurized for supervisory purposes only. This feature serves to prevent undetected leaks. If the system piping or a sprinkler is damaged, supervisory pressure is reduced and a "low air" alarm is activated.

Electrically controlled preaction systems require an electric monitored or non-monitored solenoid valve controlled by an approved release control panel with compatible detection system. In fire conditions, when the detection system operates, the system control panel energizes the solenoid valve open, causing the deluge valve to open. The sprinkler system fills with water. If any sprinklers have opened, water will flow from the system. If sprinklers have not opened, water will be in the sprinkler system piping when the sprinkler operates. A sprinkler head must open before water flows from the system.

Single Interlocked Preaction Systems are commonly used where the sprinkler system piping and/or sprinkler may be subject to damage. The most common applications are system applications where it is important to control accidental water discharge due to damaged sprinkler piping.

## 2. LISTINGS AND APPROVALS



**FM Approved:** The Viking supervised, electrically controlled Single Interlocked Preaction System is FM Approved when installed with specific components. Refer to the current FM Approval Guide. Consult the manufacturer for any component approvals too recent to appear in the FM Approval Guide.

## 3. SYSTEM OPERATION

(Refer to Figures 1-7.)

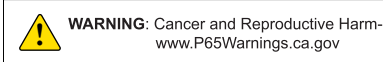

### A. IN THE SET CONDITION

System water supply pressure enters the priming chamber of the deluge valve through the 1/4" (8 mm) priming line, which includes a normally open priming valve (B.1), strainer (B.2), restricted orifice (B.3) and check valve (B.4). In the SET condition, water supply pressure is trapped in the priming chamber by the check valve and normally closed monitored or non-monitored solenoid valve (F.1). The pressure in the priming chamber holds the deluge valve clapper closed, keeping the outlet chamber and system piping dry.

### B. IN FIRE CONDITIONS

In a fire condition, when the detection system (F.4) operates, the system control panel (F.3) activates an alarm and energizes the normally closed monitored or non-monitored solenoid valve (F.1) open. Pressure is released from the priming chamber to the open drain cup faster than it is supplied through the restricted orifice (B.3). The deluge valve clapper (A.1) opens to allow water to flow into the system piping and alarm devices, causing the water motor alarm (C.2) and water flow alarms connected to the alarm pressure switch (C.1) to activate. When a sprinkler head opens, water will flow from the system.

When the deluge valve operates, the sensing end of the PORV (B.10) is pressurized, causing the PORV (B.10) to operate. When the PORV (B.10) operates, it continually vents the priming chamber to prevent the deluge valve from resetting even if the open releasing devices close. The deluge valve can only be reset after the system has been taken out of service, and the outlet chamber of the deluge valve and associated trim piping are depressurized and drained.

### C. TROUBLE CONDITIONS

If a sprinkler opens prior to operation of the detection system, or any time supervisory pressure in the sprinkler piping is lost, the air supervisory switch (E.3) will signal a low air pressure condition, but the deluge valve will NOT open. If the detection system (F.4) operates due to mechanical damage or malfunction, the deluge valve will open, but the water will be contained in the sprinkler piping. The water motor alarm and alarms connected to the alarm pressure switch (C.1) will activate.

### D. MANUAL OPERATION

Any time the handle inside the emergency release (B.11) is pulled, pressure is released from the priming chamber; the deluge valve will open. Water will flow into the system piping and alarm devices. If a sprinkler head opens, water will flow from the system.

## 4. INSTALLATION

Refer to current Viking Technical Data describing individual components of the Viking Single Interlocked Preaction System. Technical Data describing the Viking Deluge Valve, and other system components are packed with product and in the *Viking Engineering and Design Data* book. Also, refer to applicable installation standards, codes, and Authorities Having Jurisdiction.

### A. IMPORTANT SETTINGS

1. Recommended supervisory pressure in the closed sprinkler piping is 20 PSI (1.4 bar).
  - a. Where supervisory pressure is maintained at 20 PSI (1.4 bar), set the air supervisory switch (E.3) to activate at 15 PSI (1.03 bar) on pressure drop.



## TECHNICAL DATA

### SINGLE INTERLOCKED PREACTION SYSTEM WITH ELECTRIC RELEASE

The Viking Corporation, 210 N Industrial Park Drive, Hastings MI 49058

Telephone: 269-945-9501 | Technical Services: 877-384-5464 | Fax: 269-818-1680 | Email: techsvcs@vikingcorp.com

Visit the Viking website for the latest edition of this technical data page [www.vikinggroupinc.com](http://www.vikinggroupinc.com)

- b. The air supervisory switch (E.3) should be wired to activate a supervisory alarm to signal a "low air" pressure condition. Activation of an alarm to signal a high pressure condition may be required. Refer to applicable installation standards and the Authority Having Jurisdiction.

**NOTE: Installation Standards may allow supervisory pressures lower than those recommended above. When using supervisory pressures lower than the recommended setting noted above, verify that the air regulation equipment and air supervisory switches used are compatible with the supervisory pressure setting used.**

2. The alarm pressure switch (C.1) should activate when pressurized to 4 to 8 PSI (0.3 to 0.6 bar) on pressure rise and should be wired to activate the water flow alarm (C.2).

#### B. AIR SUPPLY DESIGN

The air supply compressor (G.1) should be sized to establish total required air pressure in 30 minutes. The air supply must be regulated, restricted, and maintained automatically. Air maintenance device (G.6) is used to regulate and restrict the flow of supervisory air into the sprinkler system piping.

**The air supply must be regulated** to maintain the supervisory pressure desired in the sprinkler piping. Pressures other than the pressure settings recommended in section 4. INSTALLATION, may affect operation of the system.

**The air supply must be restricted** to ensure that the automatic air supply cannot replace air as fast as it escapes when a sprinkler operates.

##### Riser-Mounted Compressors:

(Refer to Figures 2, 4, or 6.)

A riser mounted compressor (G.1) may be suitable for small electrically operated single interlocked preaction systems. However, placement of a dehydrator (G.5) and/or an air maintenance device (G.6) in the outlet piping of a riser mounted compressor may affect operation of the compressor.

#### 5. PLACING THE SYSTEM IN SERVICE

(Refer to Figures 1-7.)

**NOTE: REFER TO INSTRUCTIONS PROVIDED IN TECHNICAL DATA DESCRIBING THE VIKING DELUGE VALVE AND OTHER SYSTEM COMPONENTS. (SEE SECTION 8.)**

##### To Return the System to Service:

1. Verify that the system has been properly drained. The system main drain and auxiliary drain should be open. Verify that the emergency release (B.11) is closed.
2. Close the system main drain (D.3).
3. Restore supervisory pressure to the sprinkler piping.
  - a. Verify that the 1/2" valve in the air maintenance device by-pass trim (G.6) is closed and that both 1/4" valves are open.
4. Establish a normal condition on the release control panel (F.3).
5. Open the flow test valve (B.15).
6. Partially open the main water supply control valve (D.1).
7. When full flow develops from the flow test valve, close the flow test valve (B.15).
  - a. Verify that there is no flow from the open auxiliary drain (B.6).
8. Close the auxiliary drain.
9. Fully open and secure the main water supply control valve (D.1).
10. Verify that the alarm shut-off valve (B.9) is open and that all other valves are in their normal operating position.
11. Depress the plunger of drip check (B.7). No water should flow from the drip check when the plunger is pushed.

#### 6. EMERGENCY INSTRUCTIONS

(Refer to Figures 1-7.)

##### **⚠ WARNING**

Any system maintenance that involves placing a control valve or detection system out of service will impair the fire protection capabilities of that system. Prior to proceeding, appropriate impairment procedures per NFPA 25 shall be followed with the notification of all Authorities Having Jurisdiction. Consideration should be given to employment of a fire patrol in the affected areas.

**Failure to follow these instructions could cause improper system operation, resulting in serious personal injury and/or property damage.**



## TECHNICAL DATA

### SINGLE INTERLOCKED PREACTION SYSTEM WITH ELECTRIC RELEASE

The Viking Corporation, 210 N Industrial Park Drive, Hastings MI 49058

Telephone: 269-945-9501 | Technical Services: 877-384-5464 | Fax: 269-818-1680 | Email: techsvcs@vikingcorp.com

Visit the Viking website for the latest edition of this technical data page [www.vikinggroupinc.com](http://www.vikinggroupinc.com)

#### To Take System Out of Service:

After a fire, verify that the fire is OUT and that placing the system out of service has been authorized by the appropriate Authority Having Jurisdiction.

1. Close the water supply valve (D.1).
2. Open the system main drain (D.3).
3. Silence alarms (optional).
  - a. To silence electric alarms controlled by the Viking VFR-500 Release Control Panel (F.3): Open the panel and press "SIGNAL SILENCE".
  - b. To silence electric alarms controlled by the pressure switch (C.1) and to silence the water motor alarm (C.2): Close the alarm shut-off valve (B.9) and press Alarm Silence in the release control panel.

**NOTE: ELECTRIC ALARMS CONTROLLED BY A PRESSURE SWITCH (G.2) INSTALLED IN THE ½" (15 MM) NPT CONNECTION FOR A NON-INTERRUPTIBLE ALARM PRESSURE SWITCH CANNOT BE SHUT OFF UNTIL THE DELUGE VALVE IS RESET OR TAKEN OUT OF SERVICE.**

4. Shut off the air supply (optional) (G.1).
5. Open the auxiliary drain (B.6).

**NOTE: SPRINKLER SYSTEMS THAT HAVE BEEN SUBJECTED TO A FIRE MUST BE RETURNED TO SERVICE AS SOON AS POSSIBLE. THE ENTIRE SYSTEM MUST BE INSPECTED FOR DAMAGE, AND REPAIRED OR REPLACED AS NECESSARY.**

6. Replace any detectors that have been damaged.
7. Replace any sprinklers that have opened, been damaged, or have been exposed to fire conditions.
8. Perform all maintenance procedures recommended in Technical Data describing individual components of the system that has operated.
9. Return the system to service as soon as possible. Refer to section 5. PLACING THE SYSTEM IN SERVICE.

## 7. INSPECTIONS AND TESTS

### NOTICE

**The owner is responsible for maintaining the fire protection system and devices in proper operating condition.**

It is imperative that the system is inspected and tested on a regular basis in accordance with NFPA 25. Refer to INSPECTIONS and TESTS recommended in current Viking Technical Data describing individual components of the Viking Single Interlocked Preaction System used.

The frequency of the inspections may vary due to contaminated water supplies, corrosive water supplies, corrosive atmospheres, as well as the condition of the air supply to the system. For minimum maintenance and inspection requirements, refer to NFPA 25. In addition, the Authority Having Jurisdiction may have additional maintenance, testing, and inspection requirements that must be followed.

### WARNING

Any system maintenance that involves placing a control valve or detection system out of service will impair the fire protection capabilities of that system. Prior to proceeding, appropriate impairment procedures per NFPA 25 shall be followed with the notification of all Authorities Having Jurisdiction. Consideration should be given to employment of a fire patrol in the affected areas.

**Failure to follow these instructions could cause improper system operation, resulting in serious personal injury and/or property damage.**

#### Low-Air Pressure Alarm Test

Quarterly testing of low-air alarms is recommended.

#### To Test Sprinkler System "Low Supervisory Air" Alarm:

1. To prevent operation of the deluge valve and filling the system with water during the test, DO NOT operate the electric detection system during the test. Consider closing the main water supply control valve (D.1).
2. Fully open the sprinkler system test connection.
3. Verify that low air alarms (E.3) operate within an acceptable time period and continue without interruption.



## TECHNICAL DATA

### SINGLE INTERLOCKED PREACTION SYSTEM WITH ELECTRIC RELEASE

The Viking Corporation, 210 N Industrial Park Drive, Hastings MI 49058

Telephone: 269-945-9501 | Technical Services: 877-384-5464 | Fax: 269-818-1680 | Email: techsvcs@vikingcorp.com  
Visit the Viking website for the latest edition of this technical data page [www.vikinggroupinc.com](http://www.vikinggroupinc.com)

4. Close the test connection.
5. Establish recommended pneumatic supervisory pressure to be maintained. Refer to section 4. INSTALLATION.
6. Open the system control panel (F.3) and press RESET. Alarms should stop.

**When testing is complete, return the system to service following steps 1 through 8 below.**

#### ⚠ CAUTION

**This procedure applies only when done in conjunction with “low air” alarm testing described above.**

If the main water supply control valve (D.1) was closed in step 1, proceed with steps 3 through 9 below.

1. Verify that the pressure indicated on the priming pressure water gauge (B.12) indicates that the priming chamber is pressurized with system water supply pressure.
2. Depress the plunger of the drip check (B.7). No water should flow from the drip check when the plunger is pushed.
3. Open the flow test valve (B.15).
4. Partially open the main water supply control valve (D.1).
5. When full flow develops from the flow test valve, close the flow test valve (B.15).
6. Fully open and secure the main water supply control valve (D.1).
7. Verify that the alarm shut-off valve (B.9) is open and that all other valves are in their normal operating position.
8. Depress the plunger of the drip check (B.7). No water should flow from the drip check when the plunger is pushed.

#### Full-Flow Trip Test

Performance of a trip test is recommended annually during warm weather. Consider coordinating this test with operation testing of the detectors.

#### ⚠ CAUTION

**Performing a trip test results in operation of the deluge valve. Water will flow into the sprinkler piping. Take necessary precautions to prevent damage.**

#### To Trip Test the Electrically Controlled Single Interlocked Preaction System:

1. Notify the Authority Having Jurisdiction and those in the area affected by the test.
2. Trip the deluge valve by performing option “a” or “b” below.
  - a. Operate a detector according to the manufacturer’s instructions.
  - b. Open the door of the emergency release (B.11) and pull the handle.
3. The deluge valve should open, filling the sprinkler system with water.
  - a. Water flow alarms should operate.
4. Open the sprinkler system inspector’s test valve to verify adequate flow.

#### **When Trip Testing is Complete:**

5. Perform steps 1 through 10 of section 6. EMERGENCY INSTRUCTIONS to take the system out of service.
6. Perform steps 1 through 12 of section 5. PLACING THE SYSTEM IN SERVICE to return the system to service.
7. Notify the Authority Having Jurisdiction and those in the affected area that testing is complete.

## 8. ORDERING INSTRUCTIONS

To order a complete Single-Interlocked Preaction System with Electric Release, the following components must be purchased: Deluge Valve, conventional trim, release trim package, monitored or non-monitored solenoid Valve, and Release Control Panel.



# TECHNICAL DATA

## SINGLE INTERLOCKED PREACTION SYSTEM WITH ELECTRIC RELEASE

The Viking Corporation, 210 N Industrial Park Drive, Hastings MI 49058  
 Telephone: 269-945-9501 | Technical Services: 877-384-5464 | Fax: 269-818-1680 | Email: techsvcs@vikingcorp.com  
 Visit the Viking website for the latest edition of this technical data page [www.vikinggroupinc.com](http://www.vikinggroupinc.com)

### VALVE PART NUMBERS

DELUGE VALVES, STRAIGHT-THROUGH STYLE				
DESCRIPTION		NOMINAL SIZE	PART NUMBERS	
			Painted Red	Halar®
Threaded NPT	<b>Pipe O.D.</b>		<b>Model F-1</b>	<b>Model F-2</b>
	NPT 48 mm	1½"	12126	----
	NPT 60 mm	2"	12059	----
	NPT 65 mm	2½"	12401	12402Q/B
	BSP 48 mm	DN40	12682	----
	BSP 60 mm	DN50	12686	----
Flange / Flange	<b>Flange Drilling</b>		<b>Model F-1</b>	<b>Model F-2</b>
	ANSI	3"	12014	12015Q/B
	ANSI	4"	11953	11960Q/B
	ANSI	6"	11955	11962Q/B
	ANSI	8"	11991	11992Q/B
	ANSI/Japan	6"	11964	----
	PN10/16	DN80	12026	12027Q/B
	PN10/16	DN100	11965	11966Q/B
	PN10/16	DN150	11956	11963Q/B
	PN10	DN200	11995	11996Q/B
PN16	DN200	11999	12000Q/B	
Flange / Groove	<b>Flange Drilling / Pipe O.D.</b>		<b>Model F-1</b>	<b>Model F-2</b>
	ANSI / 89 mm	3"	12018	12019Q/B
	ANSI / 114 mm	4"	11952	11959Q/B
	ANSI / 168 mm	6"	11954	11961Q/B
	PN10/16 / 89 mm	DN80	12030	12644Q/B
	PN10/16 / 114 mm	DN100	11958	12645Q/B
	PN10/16 / 165 mm	DN150	12640	12641Q/B
	PN10/16 / 168 mm	DN150	11954	11961Q/B
Groove / Groove	<b>Pipe O.D.</b>		<b>Model F-1</b>	<b>Model F-2</b>
	48 mm	1½" / DN40	12125	12127Q/B
	60 mm	2" / DN50	12057	12058Q/B
	73 mm	2½" / DN65	12403	12404Q/B
	76 mm	DN80	12729	12730Q/B
	89 mm	3" / DN80	12022	12023Q/B
	114 mm	4" / DN100	11513	11514Q/B
	165 mm	DN150	11910	11911Q/B
	168 mm	6" / DN150	11524	11525Q/B
	219 mm	8" / DN200	11018	11118Q/B



# TECHNICAL DATA

## SINGLE INTERLOCKED PREACTION SYSTEM WITH ELECTRIC RELEASE

The Viking Corporation, 210 N Industrial Park Drive, Hastings MI 49058

Telephone: 269-945-9501 | Technical Services: 877-384-5464 | Fax: 269-818-1680 | Email: techsvcs@vikingcorp.com

Visit the Viking website for the latest edition of this technical data page [www.vikinggroupinc.com](http://www.vikinggroupinc.com)

### VALVE TRIM PACKAGE PART NUMBERS

DESCRIPTION		NOMINAL SIZE	PART NUMBERS	
Use with Straight-Through Valves	Horizontal Arrangement		Galvanized Brass	
		1½" / DN40	14635-1	14635-2
		2" / DN50	14635-1	14635-2
		2½" / DN65	14637-1	14637-2
		3" / DN80	14637-1	14637-2
		4" / DN100	14638-1	14638-2
		6" / DN150	14640-1	14640-2
		8" / DN200	14643-1	14643-2
	Vertical Arrangement	1½" / DN40	14634-1	14634-2
		2" / DN50	14634-1	14634-2
		2½" / DN65	14636-1	14636-2
		3" / DN80	14636-1	14636-2
		4" / DN100	14639-1	14639-2
		6" / DN150	14641-1	14641-2
8" / DN200	14642-1	14642-2		

### RELEASE CONTROL PANEL PART NUMBER

DESCRIPTION	PART NUMBER
VFR-500	26107

### CHECK VALVE PART NUMBERS

DESCRIPTION		NOMINAL SIZE	PART NUMBER	
<b>IN-LINE CHECK VALVE</b>				
Groove / Groove	Model L-1	1-1/2" / DN40	11054	
		2" / DN50	11059	
Threaded NPT	Model K-1	1-1/2" / DN40	10659	
		2" / DN50	10667	
<b>EASY RISER® SWING CHECK VALVE</b>				
Flange / Flange	Flange Drilling	Model F-1		
		ANSI	3"	08505
		ANSI	4"	08508
		ANSI	6"	08511
		ANSI/Japan	DN100	09039
		ANSI/Japan	DN150	09385
		ANSI/Japan	DN200	14023
		PN10/16	DN80	08796
		PN10/16	DN100	08797
		PN10/16	DN150	08835
		PN10	DN200	08836
		PN16	DN200	12355
		Flange / Groove	Flange Drilling / Pipe O.D.	Model F-1
ANSI / 89 mm	3"			08506
ANSI / 114 mm	4"			08509
ANSI / 168 mm	6"			08512
ANSI / 219 mm	8"			08515
PN10/16 / 89 mm	DN80			12648
PN10/16 / 114 mm	DN100			12649
PN10/16 / 165 mm	DN150			12652
PN10/16 / 168 mm	DN150			08512
PN10 / 219 mm	DN200			12651
PN16 / 219 mm	DN200	12650		
Groove / Groove	Pipe O.D.	Model E-1		
		73 mm	2½" / DN65	07929
			Model F-1	
		89 mm	3" / DN80	08507
		114 mm	4" / DN100	08510
		165 mm	DN150	12356
		168 mm	6" / DN150	08513
219 mm	8" / DN200	08516		

### CHECK VALVE TRIM PACKAGE PART NUMBERS

DESCRIPTION	NOMINAL SIZE	PART NUMBER
Check Valve Trim	1½" / DN40	12960
	2" / DN50	12960
	2½" / DN65	13776
	3", 4", 6", 8" / DN80, DN100, DN150, DN200	13777

### AIR MAINTENANCE DEVICE AND SUPERVISORY SWITCH PART NUMBERS

DESCRIPTION	MODEL	PART NUMBER
AIR PRESSURE MAINTENANCE DEVICE Complete with Trim	D-2	07459
PRESSURE SUPERVISORY SWITCH, 1/2" / DN15 Adjustable Range <small>10-175 PSI (0.7-12 bar)</small>	Single SPDT	PS40-1A
	Dual SPDT	PS40-2A

### RELEASE TRIM PACKAGE PART NUMBERS

DESCRIPTION	PART NUMBERS
Release Trim	Galvanized
	Brass
	10830      10832
Monitored Solenoid Valve	26785
Solenoid Valve	11601



# TECHNICAL DATA

## SINGLE INTERLOCKED PREACTION SYSTEM WITH ELECTRIC RELEASE

The Viking Corporation, 210 N Industrial Park Drive, Hastings MI 49058

Telephone: 269-945-9501 | Technical Services: 877-384-5464 | Fax: 269-818-1680 | Email: techsvcs@vikingcorp.com

Visit the Viking website for the latest edition of this technical data page [www.vikinggroupinc.com](http://www.vikinggroupinc.com)

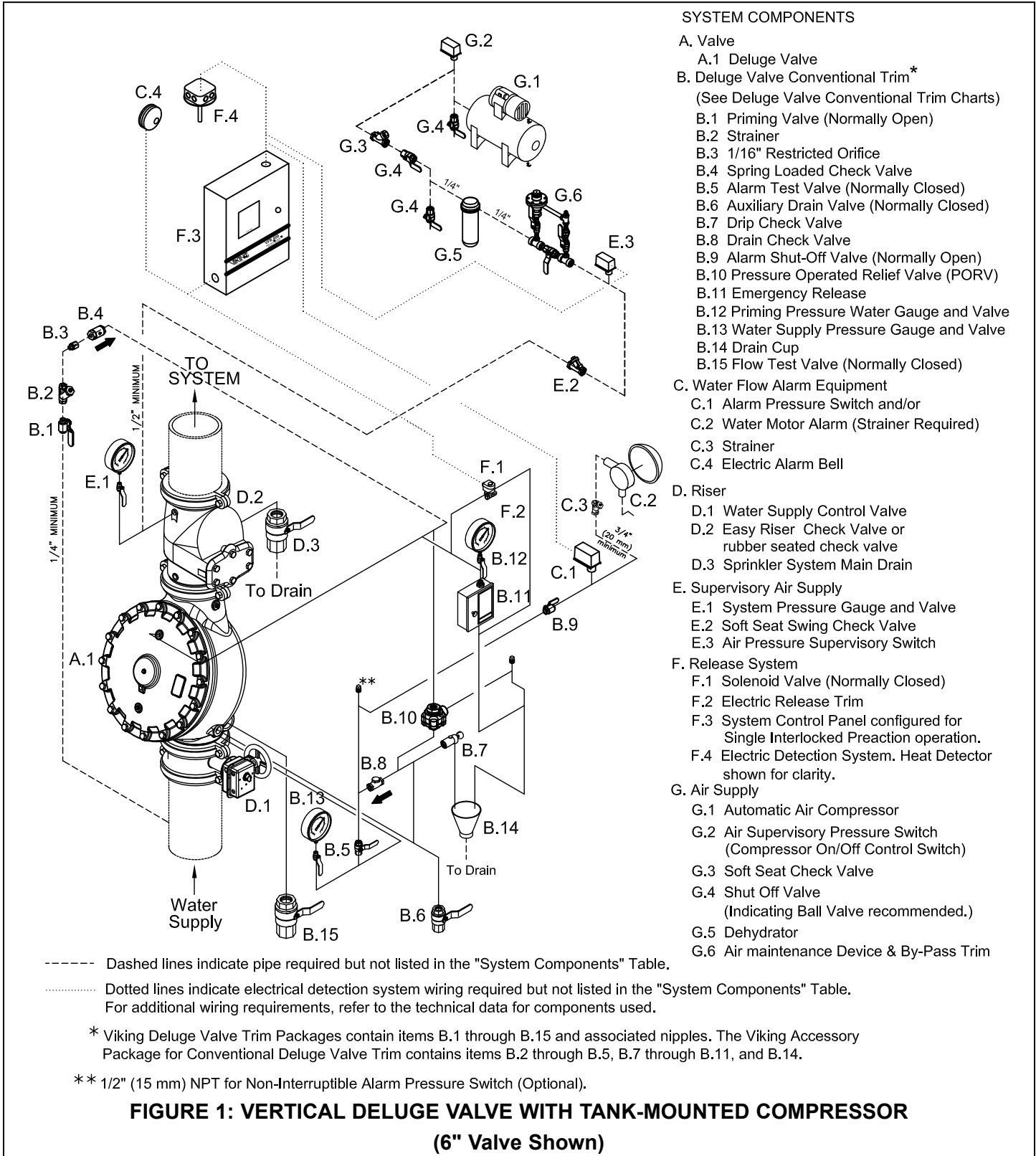



# TECHNICAL DATA

## SINGLE INTERLOCKED PREACTION SYSTEM WITH ELECTRIC RELEASE

The Viking Corporation, 210 N Industrial Park Drive, Hastings MI 49058

Telephone: 269-945-9501 | Technical Services: 877-384-5464 | Fax: 269-818-1680 | Email: techsvcs@vikingcorp.com

Visit the Viking website for the latest edition of this technical data page [www.vikinggroupinc.com](http://www.vikinggroupinc.com)

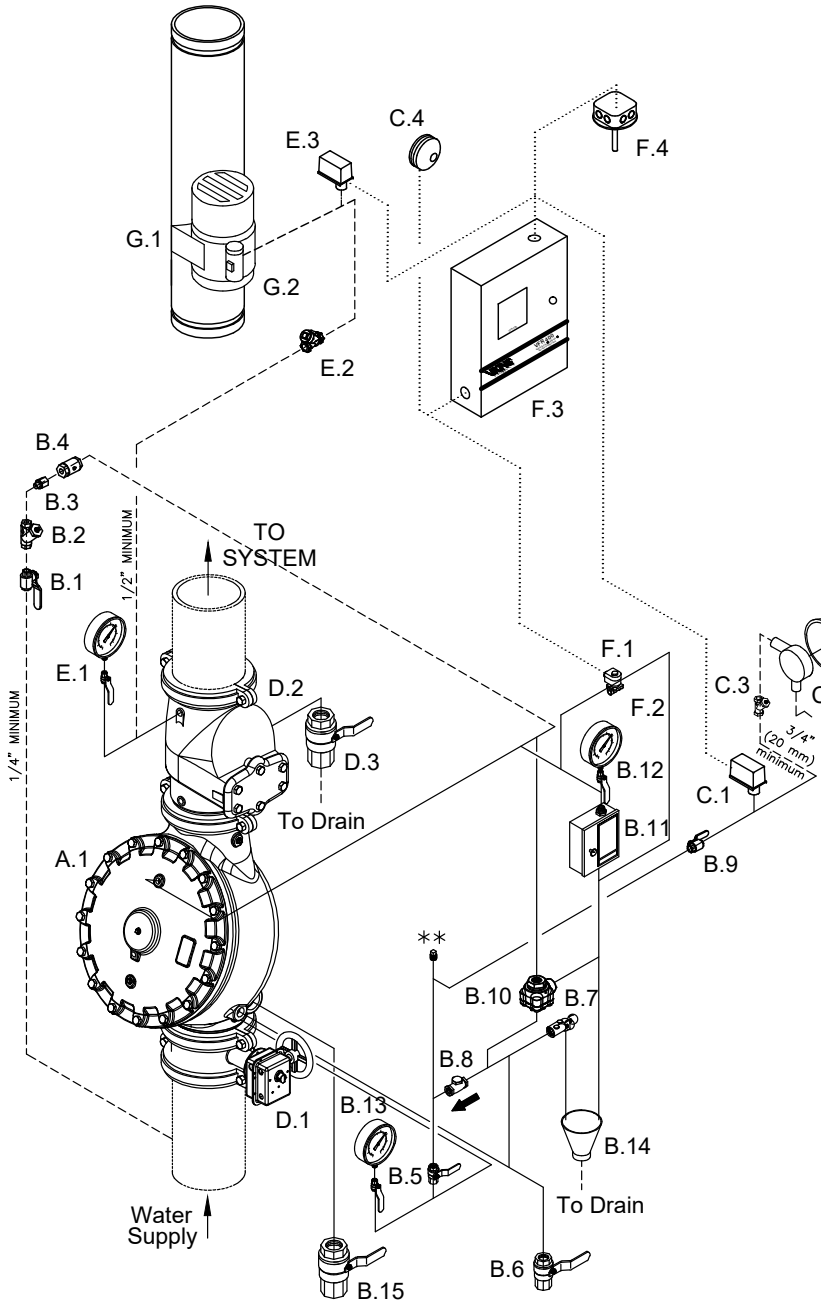

### SYSTEM COMPONENTS

- A. Valve
  - A.1 Deluge Valve
- B. Deluge Valve Conventional Trim \*
  - (See Deluge Valve Conventional Trim Charts)
  - B.1 Priming Valve (Normally Open)
  - B.2 Strainer
  - B.3 1/16" Restricted Orifice
  - B.4 Spring Loaded Check Valve
  - B.5 Alarm Test Valve (Normally Closed)
  - B.6 Auxiliary Drain Valve (Normally Closed)
  - B.7 Drip Check Valve
  - B.8 Drain Check Valve
  - B.9 Alarm Shut-Off Valve (Normally Open)
  - B.10 Pressure Operated Relief Valve (PORV)
  - B.11 Emergency Release
  - B.12 Priming Pressure Water Gauge and Valve
  - B.13 Water Supply Pressure Gauge and Valve
  - B.14 Drain Cup
  - B.15 Flow Test Valve (Normally Closed)
- C. Water Flow Alarm Equipment
  - C.1 Alarm Pressure Switch and/or
  - C.2 Water Motor Alarm (Strainer Required)
  - C.3 Strainer
  - C.4 Electric Alarm Bell
- D. Riser
  - D.1 Water Supply Control Valve
  - D.2 Easy Riser Check Valve or rubber seated check valve
  - D.3 Sprinkler System Main Drain
- E. Supervisory Air Supply
  - E.1 System Pressure Gauge and Valve
  - E.2 Soft Seat Swing Check Valve
  - E.3 Air Pressure Supervisory Switch
- F. Release System
  - F.1 Solenoid Valve (Normally Closed)
  - F.2 Electric Release Trim
  - F.3 System Control Panel configured for Single Interlocked Preaction operation.
  - F.4 Electric Detection System. Heat Detector shown for clarity.
- G. Air Supply
  - G.1 Riser Mounted Air Compressor
  - G.2 Air Supervisory Pressure Switch (Compressor On/Off Control Switch)

----- Dashed lines indicate pipe required but not listed in the "System Components" Table.

..... Dotted lines indicate electrical detection system wiring required but not listed in the "System Components" Table. For additional wiring requirements, refer to technical data for components used.

\* Viking Deluge Valve Trim Packages contain items B.1 through B.15 and associated nipples. The Viking Accessory Package for Conventional Deluge Valve Trim contains items B.2 through B.5, B.7 through B.11, and B.14.

\*\* 1/2" (15 mm) NPT for Non-Interruptible Alarm Pressure Switch (Optional).

**FIGURE 2: VERTICAL DELUGE VALVE WITH RISER-MOUNTED COMPRESSOR (6" Valve Shown)**



# TECHNICAL DATA

## SINGLE INTERLOCKED PREACTION SYSTEM WITH ELECTRIC RELEASE

The Viking Corporation, 210 N Industrial Park Drive, Hastings MI 49058

Telephone: 269-945-9501 | Technical Services: 877-384-5464 | Fax: 269-818-1680 | Email: techsvcs@vikingcorp.com

Visit the Viking website for the latest edition of this technical data page [www.vikinggroupinc.com](http://www.vikinggroupinc.com)

### SYSTEM COMPONENTS

- A. Valve
  - A.1 Deluge Valve
- B. Deluge Valve Conventional Trim \*
  - (See Deluge Valve Conventional Trim Charts)
  - B.1 Priming Valve (Normally Open)
  - B.2 Strainer
  - B.3 1/16" Restricted Orifice
  - B.4 Spring Loaded Check Valve
  - B.5 Alarm Test Valve (Normally Closed)
  - B.6 Auxiliary Drain Valve (Normally Closed)
  - B.7 Drip Check Valve
  - B.8 Drain Check Valve
  - B.9 Alarm Shut-Off Valve (Normally Open)
  - B.10 Pressure Operated Relief Valve (PORV)
  - B.11 Emergency Release
  - B.12 Priming Pressure Water Gauge and Valve
  - B.13 Water Supply Pressure Gauge and Valve
  - B.14 Drain Cup
  - B.15 Flow Test Valve (Normally Closed)
- C. Water Flow Alarm Equipment
  - C.1 Alarm Pressure Switch and/or
  - C.2 Water Motor Alarm (Strainer Required)
  - C.3 Strainer
  - C.4 Electric Alarm Bell
- D. Riser
  - D.1 Water Supply Control Valve
  - D.2 Easy Riser Check Valve or rubber seated check valve
  - D.3 Sprinkler System Main Drain
- E. Supervisory Air Supply
  - E.1 System Pressure Gauge and Valve
  - E.2 Soft Seat Swing Check Valve
  - E.3 Air Pressure Supervisory Switch
- F. Release System
  - F.1 Solenoid Valve (Normally Closed)
  - F.2 Electric Release Trim
  - F.3 System Control Panel configured for Single Interlocked Preaction operation.
  - F.4 Electric Detection System. Heat Detector shown for clarity.
- G. Air Supply
  - G.1 Automatic Air Supply, Air Compressor and Tank shown for clarity.
  - G.2 Air Supervisory Pressure Switch (Compressor On/Off Control Switch)
  - G.3 Soft Seat Check Valve
  - G.4 Shut Off Valve (Indicating Ball Valve recommended.)
  - G.5 Dehydrator
  - G.6 Air maintenance Device & By-Pass Trim

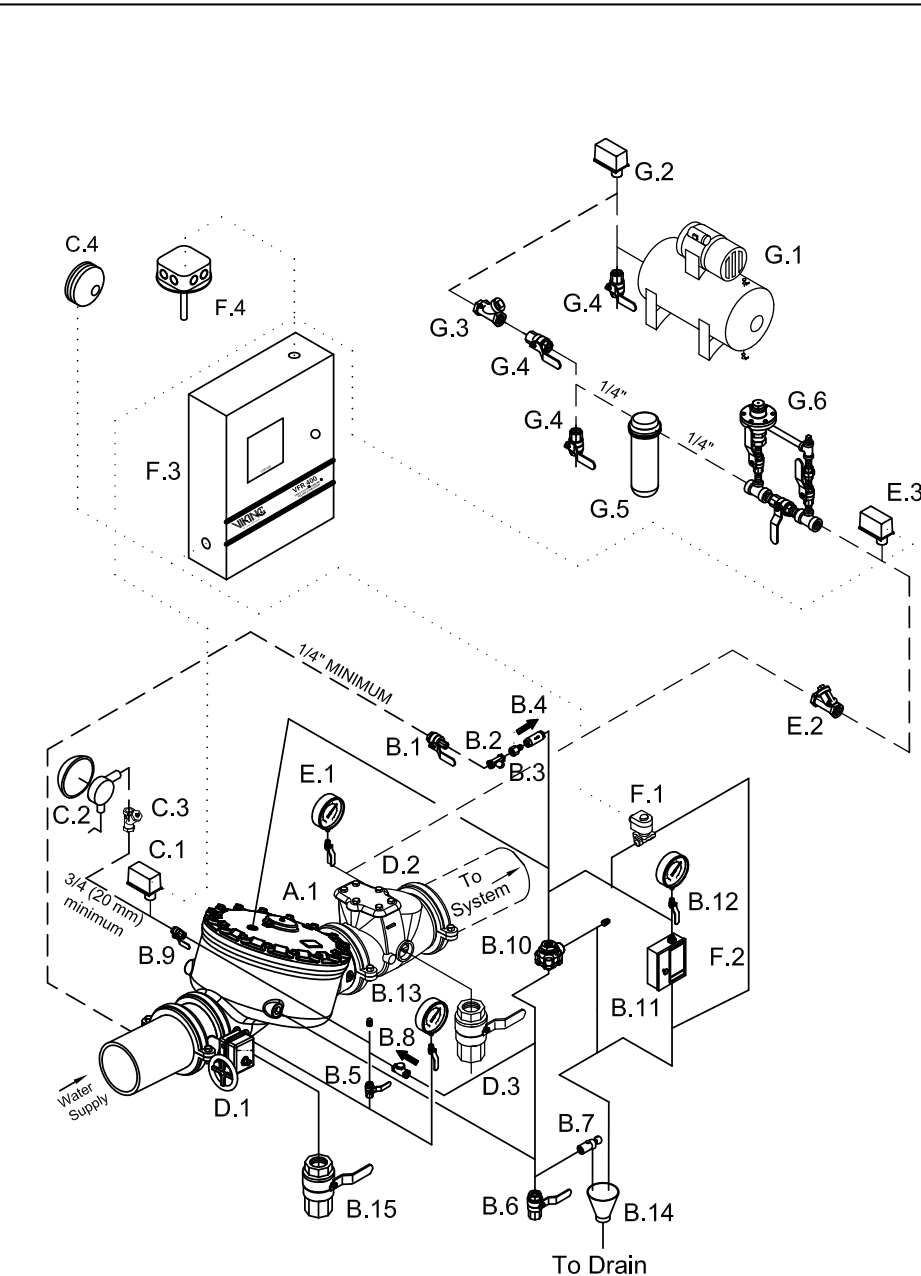

--- Dashed lines indicate pipe required but not listed in the "System Components" Table.  
 ..... Dotted lines indicate electrical detection system wiring is required but is not listed in the "System Components" Table. For additional wiring requirements, refer to technical data for components used.

\* Viking Deluge Valve Trim Packages contain items B.1 through B.15 and associated nipples. The Viking Accessory Package for Conventional Deluge Valve Trim contains items B.2 through B.5, B.7 through B.11, and B.14.

**FIGURE 3: HORIZONTAL DELUGE VALVE WITH TANK-MOUNTED COMPRESSOR (6" Valve Shown)**



# TECHNICAL DATA

## SINGLE INTERLOCKED PREACTION SYSTEM WITH ELECTRIC RELEASE

The Viking Corporation, 210 N Industrial Park Drive, Hastings MI 49058

Telephone: 269-945-9501 | Technical Services: 877-384-5464 | Fax: 269-818-1680 | Email: techsvcs@vikingcorp.com

Visit the Viking website for the latest edition of this technical data page [www.vikinggroupinc.com](http://www.vikinggroupinc.com)

### SYSTEM COMPONENTS

- A. Valve
  - A.1 Deluge Valve
- B. Deluge Valve Conventional Trim \*
  - (See Deluge Valve Conventional Trim Charts)
  - B.1 Priming Valve (Normally Open)
  - B.2 Strainer
  - B.3 1/16" Restricted Orifice
  - B.4 Spring Loaded Check Valve
  - B.5 Alarm Test Valve (Normally Closed)
  - B.6 Auxiliary Drain Valve (Normally Closed)
  - B.7 Drip Check Valve
  - B.8 Drain Check Valve
  - B.9 Alarm Shut-Off Valve (Normally Open)
  - B.10 Pressure Operated Relief Valve (PORV)
  - B.11 Emergency Release
  - B.12 Priming Pressure Water Gauge and Valve
  - B.13 Water Supply Pressure Gauge and Valve
  - B.14 Drain Cup
  - B.15 Flow Test Valve (Normally Closed)
- C. Water Flow Alarm Equipment
  - C.1 Alarm Pressure Switch and/or
  - C.2 Water Motor Alarm (Strainer Required)
  - C.3 Strainer
  - C.4 Electric Alarm Bell
- D. Riser
  - D.1 Water Supply Control Valve
  - D.2 Easy Riser Check Valve or rubber seated check valve
  - D.3 Sprinkler System Main Drain
- E. Supervisory Air Supply
  - E.1 System Pressure Gauge and Valve
  - E.2 Soft Seat Swing Check Valve
  - E.3 Air Pressure Supervisory Switch
- F. Release System
  - F.1 Solenoid Valve (Normally Closed)
  - F.2 Electric Release Trim
  - F.3 System Control Panel configured for Single Interlocked Preaction operation.
  - F.4 Electric Detection System. Heat Detector shown for clarity.
- G. Air Supply
  - G.1 Riser Mounted Air Compressor
  - G.2 Air Supervisory Pressure Switch (Compressor On/Off Control Switch)

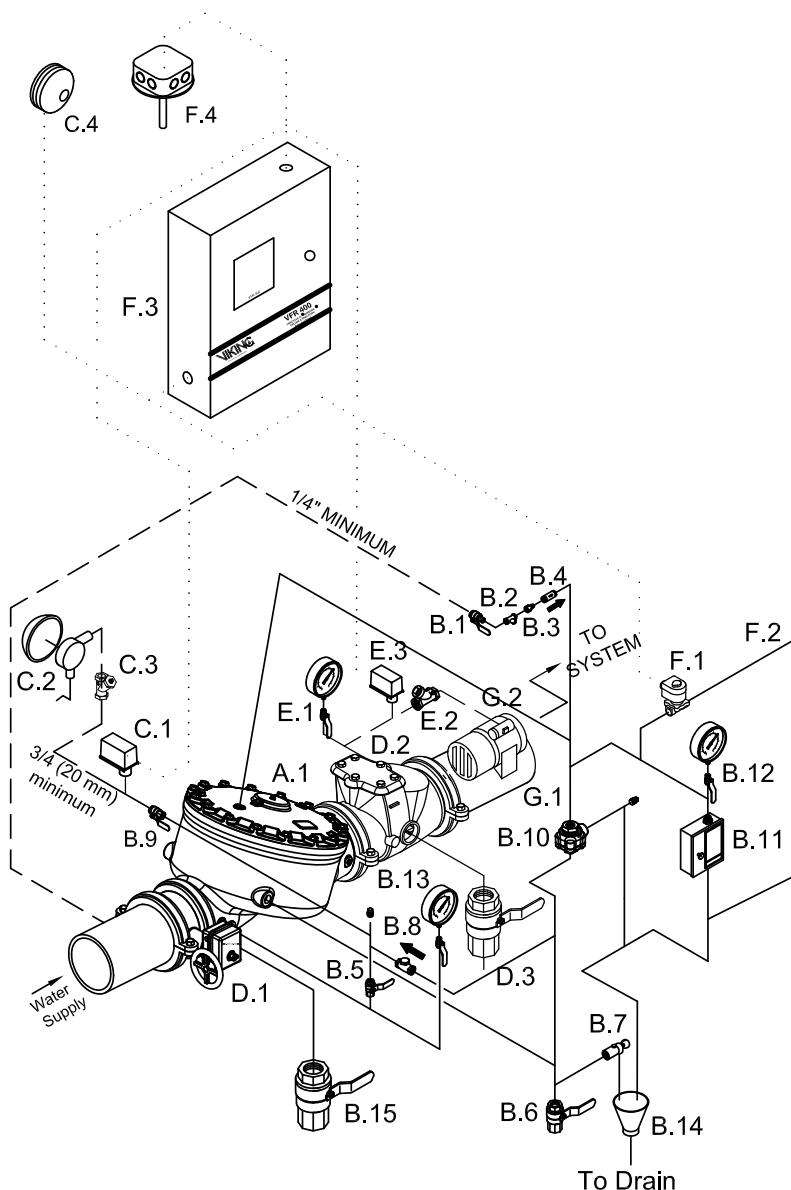

--- Dashed lines indicate pipe is required but is not listed in the "System Components" Table.

..... Dotted lines indicate electrical detection system wiring is required but is not listed in the "System Components" Table. For additional wiring requirements, refer to technical data for components used.

\* Viking Deluge Valve Trim Packages contain items B.1 through B.15 and associated nipples. The Viking Accessory Package for Conventional Deluge Valve Trim contains items B.2 through B.5, B.7 through B.11, and B.14.

**FIGURE 4: HORIZONTAL DELUGE VALVE WITH RISER-MOUNTED COMPRESSOR  
(6" Valve Shown)**