



## TECHNICAL DATA SHEET

## MONITORED SOLENOID VALVES

### 1. PRODUCT IDENTIFICATION

This document covers the following product(s), hereafter referred to as “solenoid valve”:

Monitored Solenoid Valve

### 2. DESCRIPTION

The solenoid valve has both an inlet and an outlet. It is a pack-less, internal pilot-operated valve, suitable for use in releasing water pressure from the priming chamber of the Viking F deluge valve, VXD deluge valve, the Viking Model J flow control valves, and the EA-1 Accelerator. The solenoid valve also has a floating diaphragm construction, which requires a minimum pressure drop across it to operate properly.

The solenoid valve is for use with system control units that are listed and/or approved for releasing service for water-based fire protection systems. The solenoid valve is NFPA 13 solenoid monitoring-compliant.



Governmental codes, ordinances, and standards may apply and may differ from one another.

### WARNING

Cancer and Reproductive Harm [www.P65Warnings.ca.gov](http://www.P65Warnings.ca.gov).

#### 2.1 Product Features

- Part number: 26785
- Body style: straight-through
- Required accessories: a 50 mesh strainer. It is included as part of the Model F and VXD deluge valve trim, the Model J flow control valve trim, as well as the EA-1 Accelerator trim.

### 3. LISTING AND APPROVALS



**cULus Listed** - YIOZ.MP618, shut-off valve, ordinary locations per UL429 (under ASCO X210575972001F1)

**UL Complementary Listed** - VLTR.MP618, per UL429A (under ASCO X210575972001F1)



**FM Approved** - As part of Viking Deluge Valves and EA-1 Accelerator



**CSA Certified** - Shut-off valve, file 010381 per CSA139 and UL429 (under ASCO X210575972001F1)



**CE Directives Applicable** - CE Directives Applicable  
• RoHS 2011/65/E

**TECHNICAL DATA SHEET**
**MONITORED  
SOLENOID VALVES**
**4. TECHNICAL SPECIFICATIONS**
**4.1 Product Specifications**

Parameter	Value
Rated pressure range	5 PSI (0.34 bar) to 300 PSI (20.7 bar)
Maximum ambient temperature	130°F (54°C)
Normal position	Normally Closed (NC)
Enclosure type	NEMA 2, 3, 3S, 4, 4X <sup>1</sup>
Associated Viking systems	Deluge and preaction, SureFire, or Firecycle
Orifice	3/4"
Wattage	9.0
DC current	338 mA
Voltage	24 VDC
Cv Factor	4.0
Connections	1/2" (15 mm) NPT, female
<sup>1</sup> Enclosure types: (2) drip-proof, (3 & 3S) rain-tight, (4 & 4X) water-tight	

**4.2 Material Specifications**

Components	Material
Body	Brass
Seals and discs	Buna N
Core tube	305 stainless steel
Core and plugnut	430F stainless steel
Springs	302 stainless steel



4.3 Dimensions

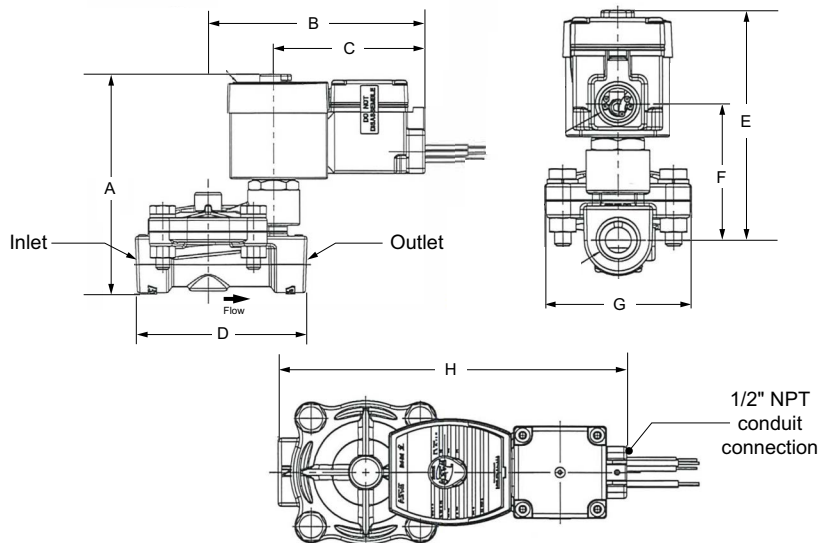

Figure – 1: Dimensions

Unit	A	B	C	D	E	F	G	H
Inches	5	5	3.5	3.9	4.3	2.6	2.8	6.6
mm	127	127	88	100	110	65	70	168

4.4 Wiring Diagram

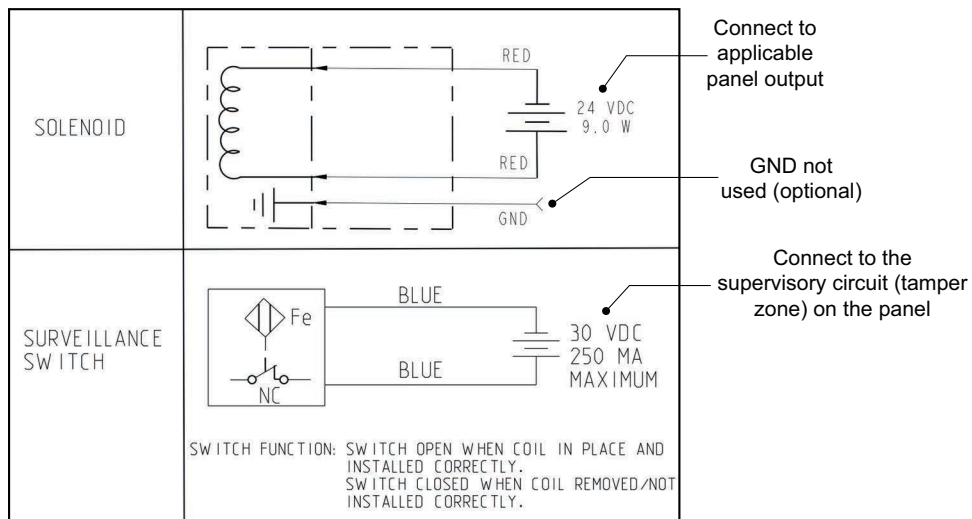

Figure – 2



## 5. INSTALLATION INSTRUCTIONS

1. Check the nameplate for the correct unit, including voltage and mode of operation.
2. Mount the solenoid valve.

**NOTE: Standard solenoid valves may be mounted in any position. However, for optimum life and performance, solenoid valves should be mounted so that the coil is upright.**

3. The solenoid valve should be installed in the correct direction, according to the inlet and outlet placement on the trim drawing.
4. Install the 50 mesh strainer to the valve's inlet at the priming line connection, as indicated on Viking's model trim drawing.
5. Apply pipe-joint compound sparingly to the connecting pipe's male-end threads only.

### CAUTION

**Solenoid valve malfunction or damage. If the pipe-joint compound is applied to the valve threads or the first two male threads on the connecting pipe, the compound may enter the valve and cause operation difficulty or leakage.**

6. Once the installation is completed, perform the proper system inspection and testing.

## 6. OPERATION

The solenoid valve is an internal pilot operated valve with pilot and bleed orifices utilizing line pressure for operation. Normally closed, de-energized valves open when energized. Power is applied to the solenoid valve coil, causing the solenoid valve core to lift, opening the pilot orifice to the outlet side of the valve. This relieves pressure on the top side of the diaphragm and allows the line pressure to open the valve. When de-energized, the solenoid core reseals the pilot orifice, allowing the line pressure to build above the diaphragm, closing the valve.

Normally closed solenoid valves are commonly used as releases for Viking deluge and flow control valves. Opening the solenoid valve allows the deluge or flow control valve to open.

**NOTE: When using a normally closed solenoid valve as a release, a system will not operate automatically on total loss of power. For this reason, it is recommended and normally required that an emergency battery back-up, supervised power supply be provided to maintain fire protection during interruptions of the main power system and to meet the requirements of appropriate Authorities Having Jurisdiction (AHJ).**



## 7. INSPECTIONS, TESTS, AND MAINTENANCE

### NOTICE

The owner is responsible for maintaining the fire protection system and devices in proper operating condition. For minimum maintenance and inspection requirements, refer to recognized standards, such as those produced by NFPA, LPCB, and VdS, which describe sprinkler system care and maintenance. The AHJ may have additional inspection, testing, and maintenance requirements that must be followed.

### ⚠ WARNING

Any system maintenance or testing that involves placing a control valve or detection system out of service may eliminate the fire protection of that system. Prior to proceeding, notify all AHJs. Consideration should be given to employment of a fire patrol in the affected area. Failure to follow these instructions could cause improper system operation, resulting in serious personal injury and/or property damage.

### ⚠ WARNING

Prior to operating the solenoid valve, be sure to close the system control valve to avoid unintentional operation of the deluge valve.

#### Inspections:

It is imperative that the system is inspected and tested on a regular basis and in accordance with NFPA 25 standards. The frequency of the inspections may vary due to contaminated water supplies, corrosive water supplies, or corrosive atmospheres. In addition, the alarm devices, detection systems, or other connected trim may require a more frequent schedule. Refer to the system description and applicable codes for minimum requirements.

- The solenoid valve must be operated at least monthly. The solenoid valve must open and close freely.
- When open, the water flow must be clear and flushed out at the proper flow rate. When closed, a total water shut-off must be observed.
- After the test, the strainer must be cleaned. Prior to cleaning the strainer, the priming line valve must be closed and the priming line depressurized. After the strainer is cleaned, the priming line valve must be re-opened.
- The valve must be inspected at least monthly for cracks, corrosion, leakage, and flushed out or replaced, as necessary.
- At least annually, the valve diaphragms and seats must be inspected and, if necessary, replaced.

### NOTICE

**Do not disassemble the solenoid valve. Disassembling the solenoid valve may cause solenoid valve damage or malfunction.**

- After maintenance is completed, operate the valve a few times to ensure proper operation. A metallic “click” signifies the solenoid valve is operating.
- It is recommended that the valve be replaced every seven years. Shorter intervals may be required if the valve is subject to corrosive water supplies or atmospheres.
- All service must be performed by qualified personnel. Once the inspection is completed or the valve is replaced, the entire system must be checked for proper operation. See appropriate system description and testing instructions for additional information.

**TECHNICAL DATA SHEET**
**MONITORED  
SOLENOID VALVES**
**8. CONTACT**

The solenoid valve and its required accessory are available through Viking distributors only. Contact your local Viking sales office which can be found on our website:

Americas and Asia: [www.vikinggroupinc.com/locations](http://www.vikinggroupinc.com/locations) OR Europe, Middle East, Africa (EMEA): [www.viking-emea.com/contact](http://www.viking-emea.com/contact)

**Manufacturer:**

ASCO L.P.  
160 Park Ave  
Florham Park, NJ 07932  
United States

**Importer EU:**

Viking S.A.  
21, Z.I., Haneboesch  
L-4562 Differdange / Niederkorn  
Tel.: +352 58 37 37 – 1  
Fax: +352 58 37 36  
[vikinglux@viking-emea.com](mailto:vikinglux@viking-emea.com)

**Asia Pacific (APAC) Main Office:**

The Viking Corporation (Far East) Pte. Ltd.  
69 Tuas View Square  
Westlink Techpark, Singapore 637621  
Tel: (+65) 6 278 4061  
Fax: (+65) 6 278 4609  
[vikingAPAC@vikingcorp.com](mailto:vikingAPAC@vikingcorp.com)

**Distributor**

The Viking Corporation  
5150 Beltway SE  
Caledonia, MI 49316  
Tel.: (800) 968–9501  
Fax: 269–818–1680  
Technical Services: 1–877–384–5464  
[techsvcs@vikingcorp.com](mailto:techsvcs@vikingcorp.com)