



# TECHNICAL DATA

## MODEL VXD DELUGE SYSTEM WITH ELECTRIC RELEASE

The Viking Corporation, 210 N Industrial Park Drive, Hastings MI 49058  
 Telephone: 269-945-9501 Technical Services: 877-384-5464 Fax: 269-818-1680 Email: techsvcs@vikingcorp.com  
 Visit the Viking website for the latest edition of this technical data page [www.vikinggroupinc.com](http://www.vikinggroupinc.com)

### 1. INTRODUCTION

Viking VXD Deluge Systems utilize a Viking Model VXD Deluge Valve to control the water supply to system piping equipped with open sprinklers and/or spray nozzles. The system piping remains empty until the deluge valve is activated by operation of the release system. Deluge systems are commonly used where it is desirable to simultaneously spray water from all open sprinklers and/or nozzles on the system when it operates. Electrically controlled deluge systems require an electric solenoid valve controlled by an approved system release control panel with compatible detection system.

In fire conditions, when the detection system operates, the system release control panel energizes solenoid valve open, causing the deluge valve to open and allowing water to enter the system piping. Water will flow from any open sprinklers and/or spray nozzles on the system.

### 2. LISTINGS AND APPROVALS



cULus Listed - Categories VLFT and VLFT7



FM Approved

### 3. ORDERING INFORMATION

#### 3.1 Options and Configurations

The Model VXD Deluge System with Electric Release can be ordered in the following configurations:

- Pre-Trimmed Riser (PTR) assembly - Refer to section 3.2
- Pre-Trimmed (PT) - Refer to section 3.3
- Loose configurations (with the same trim configuration as PT) - Refer to section 3.4

#### Monitored Solenoid Option

Each of the above configurations can be ordered with a monitored or non-monitored release solenoid. The monitored solenoid is a new option, which offers an NFPA 13 solenoid monitoring-compliant solution. For more information, refer to F\_031225.



**WARNING:** Cancer and Reproductive Harm  
[www.P65Warnings.ca.gov](http://www.P65Warnings.ca.gov)

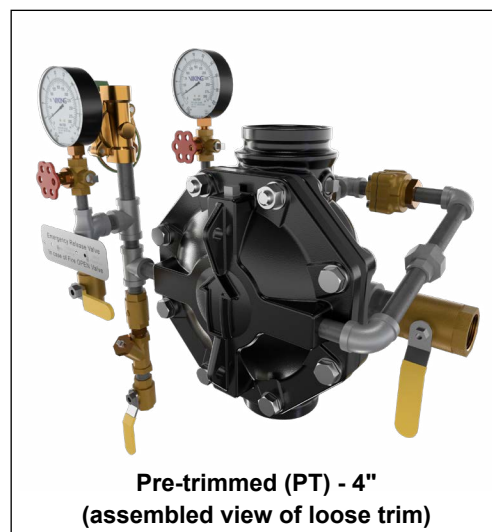



## TECHNICAL DATA

### MODEL VXD DELUGE SYSTEM WITH ELECTRIC RELEASE

The Viking Corporation, 210 N Industrial Park Drive, Hastings MI 49058  
 Telephone: 269-945-9501 Technical Services: 877-384-5464 Fax: 269-818-1680 Email: techsvcs@vikingcorp.com  
 Visit the Viking website for the latest edition of this technical data page [www.vikinggroupinc.com](http://www.vikinggroupinc.com)



**Figure 2: Pre-trimmed - 4\"**  
**(assembled loose trim)**

### 3.2 Pre-Trimmed Riser (PTR)

Pre-Trimmed Riser packages come completely assembled and ready to install. These packages include the Model VXD deluge valve with trim, additional components shown below, and come with galvanized pipe and groove/groove connections only.

The Pre-Trimmed Riser packages include the following components:

- Model VXD Deluge valve
- completely assembled trim
- electric release solenoid
- water supply control valve
- water pressure gauge
- grooved coupling
- water flow pressure switches
- complete drain manifold with hoses and drain cup

**Table 1: Pre-Trimmed Riser (PTR)  
Model VXD Deluge System  
with Electric Release (Vertical)**

Nominal Size (inch)	Part Numbers <sup>1</sup>	
	Non-Monitored Solenoid	Monitored Solenoid
1½	24883	28123
2	24893	28124
2½	25464	28125
3	25396	28126
4	25411	28127
6	25437	28128
8	25497	28129
10	Not available	Not available

1. Pre-trimmed riser assemblies include galvanized trim components and grooved pipe connections.



## TECHNICAL DATA

### MODEL VXD DELUGE SYSTEM WITH ELECTRIC RELEASE

The Viking Corporation, 210 N Industrial Park Drive, Hastings MI 49058  
 Telephone: 269-945-9501 Technical Services: 877-384-5464 Fax: 269-818-1680 Email: techsvcs@vikingcorp.com  
 Visit the Viking website for the latest edition of this technical data page [www.vikinggroupinc.com](http://www.vikinggroupinc.com)

#### 3.3 Pre-trimmed (PT) Assemblies

Pre-trimmed packages come completely assembled and ready to install. These packages include the Model VXD deluge valve with trim as shown below come with galvanized pipe and groove/groove connections only.

- Model VXD Deluge valve
- completely assembled trim
- electric release solenoid
- water pressure gauges
- loose drain cup

Refer to Table 2 for ordering information.

#### 3.4 Loose Trim Packages

**NOTICE: The deluge valve must be trimmed as shown on the trim diagrams. Any deviation from trim size or arrangement may affect the proper operation of the deluge valve. Refer to the appropriate trim diagram for the system size and type to be used.**

Loose trim packages come loose in a box and assembly is required. These packages do NOT include the Model VXD deluge valve which must be ordered separately. The Model VXD deluge valve can be ordered with flange/flange or groove/groove connections (refer to the Model VXD deluge valve technical data). The loose trim packages can be ordered with galvanized or brass trim, refer to Table 2 below.

These packages include the following components:

- all required trim components
- electric release solenoid
- water pressure gauge
- loose drain cup

Refer to the "System Components" for more information.



Figure 1: Pre-Trimmed Riser - 4"

**Table 2: Pre-trimmed (PT) and Loose trim  
Model VXD Deluge System  
with Electric Release (Vertical)**

	Pre-trimmed		Loose trim <sup>1</sup>			
	Non-Monitored Solenoid	Monitored Solenoid	Non-Monitored Solenoid		Monitored Solenoid	
	Galvanized	Galvanized	Galvanized	Brass	Galvanized	Brass
1-½	23546	28064	23545-1	23545-2	28063-1	28063-2
2	23578	28068	23577-1	23577-2	28067-1	28067-2
2½	23599	28053	23598-1	23598-2	28052-1	28052-2
3	23620	28070	23619-1	23619-2	28069-1	28069-2
4	23641	28046	23640-1	23640-2	28044-1	28044-2
6	23663	28072	23662-1	23662-2	28071-1	28071-2
8	23684	28097	23683-1	23683-2	28096-1	28096-2
10	23745	28099	23744-1	23744-2	28098-1	28098-2

1. Loose trim packages do NOT include the deluge valve. Refer to the Model VXD Deluge Valve technical data sheet for more information.



# TECHNICAL DATA

## MODEL VXD DELUGE SYSTEM WITH ELECTRIC RELEASE

The Viking Corporation, 210 N Industrial Park Drive, Hastings MI 49058  
 Telephone: 269-945-9501 Technical Services: 877-384-5464 Fax: 269-818-1680 Email: techsvcs@vikingcorp.com  
 Visit the Viking website for the latest edition of this technical data page www.vikinggroupinc.com

### 4. SYSTEM COMPONENTS

#### 4.1 Deluge System PTR Components

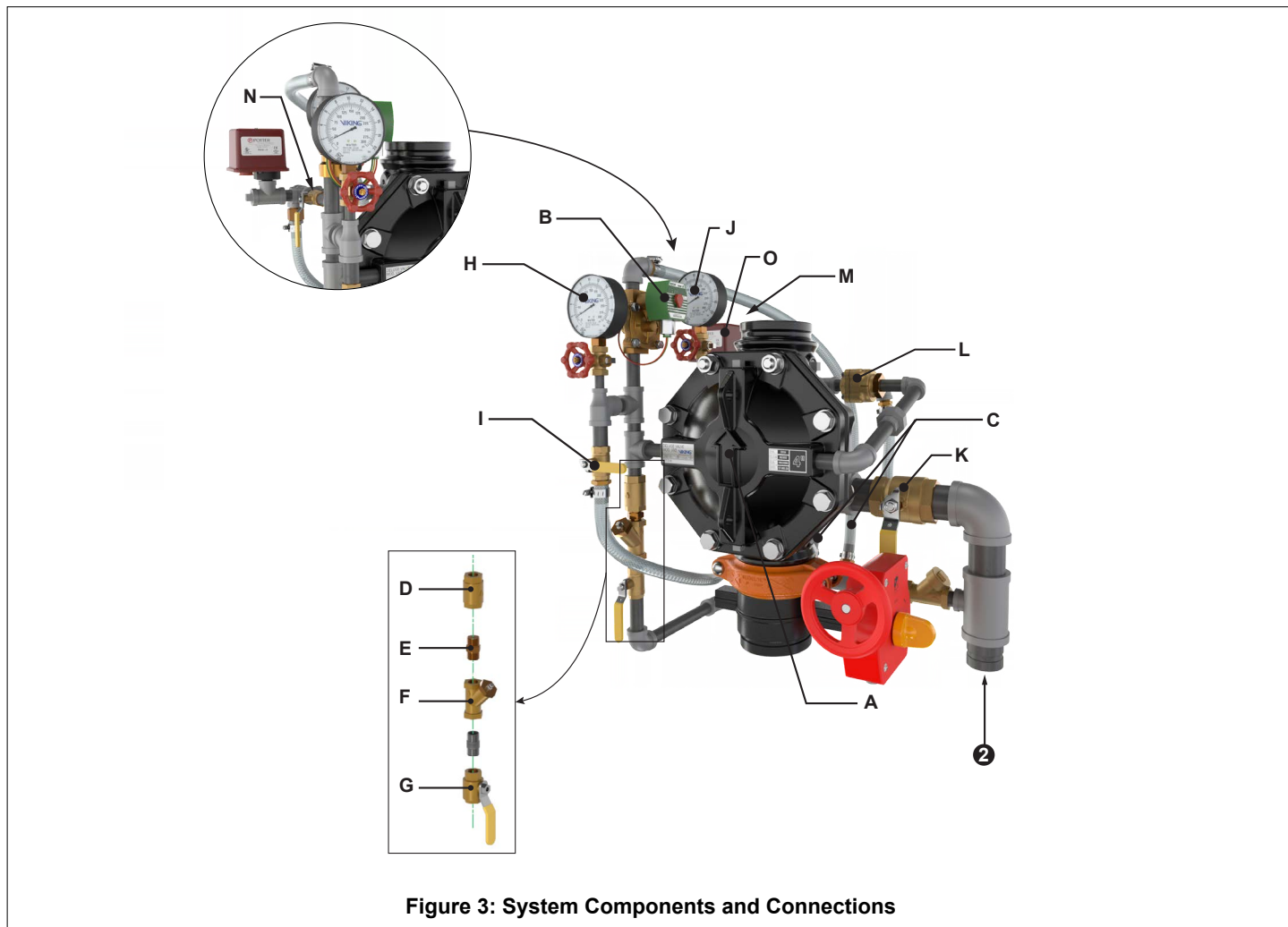

Figure 3: System Components and Connections

Item	Description	Item	Description
A	Deluge valve	I	Emergency release valve (normally closed)
B	Solenoid valve (normally closed)	J	Water supply pressure gauge
C	Drain manifold	K	Flow test valve (normally closed)
D	In-line check valve	L	Pressure Operated Relief Valve (P.O.R.V.)
E	1/8" Restricted orifice	M	Swing check valve (not shown)
F	Y-strainer	N	Alarm test valve (normally closed)
G	Priming valve (normally open)	O	PS-10 alarm pressure switch
H	Prime pressure gauge	#2	Drain connection point



# TECHNICAL DATA

## MODEL VXD DELUGE SYSTEM WITH ELECTRIC RELEASE

The Viking Corporation, 210 N Industrial Park Drive, Hastings MI 49058  
 Telephone: 269-945-9501 Technical Services: 877-384-5464 Fax: 269-818-1680 Email: techsvcs@vikingcorp.com  
 Visit the Viking website for the latest edition of this technical data page www.vikinggroupinc.com

### 4.2 Deluge System PTR Components

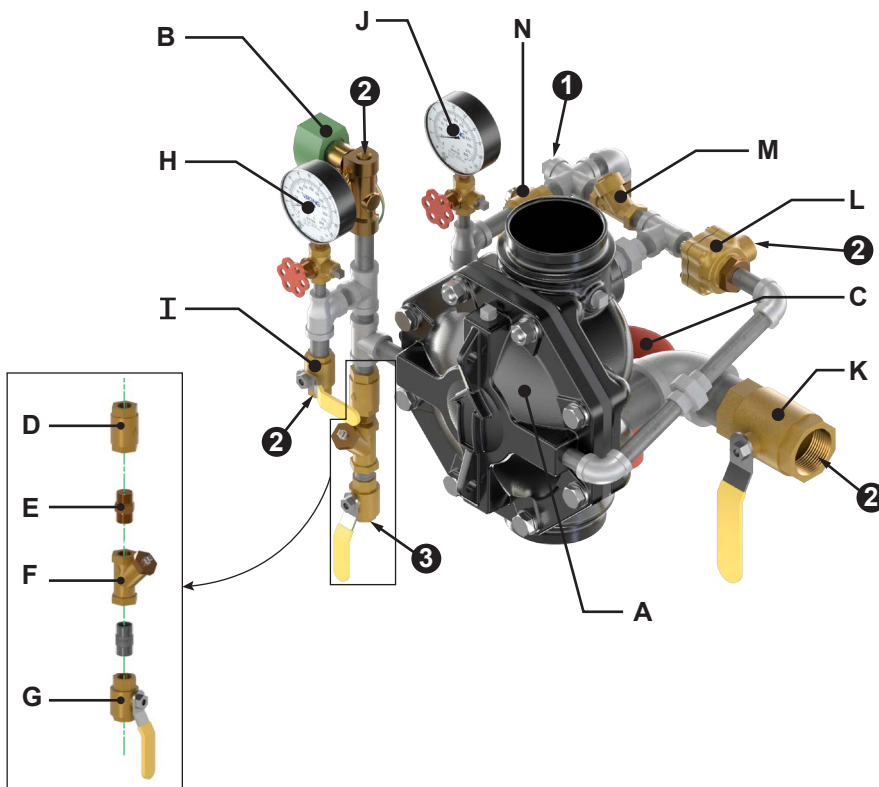

Figure 4: System Components and Connections

Item	Description	Item	Description	Item	Description
A	Deluge valve	H	Prime pressure gauge	1	Water flow alarm (example: PS-10) connection point (device purchased separately)
B	Solenoid valve (normally closed)	I	Emergency release valve (normally closed)		
C	Drain cup	J	Water supply pressure gauge		
D	In-line check valve	K	Flow test valve (normally closed)	2*	Drain connection point (piping not provided)
E	1/8" Restricted orifice	L	Pressure Operated Relief Valve (P.O.R.V.)		
F	Y-strainer	M	Swing check valve	3	Prime supply connection point (must be piped to upstream of main water supply valve; piping not provided)
G	Priming valve (normally open)	N	Alarm test valve (normally closed)		

\*PTR packages include pre-installed drain manifolds with hoses and fittings.



## TECHNICAL DATA

### MODEL VXD DELUGE SYSTEM WITH ELECTRIC RELEASE

The Viking Corporation, 210 N Industrial Park Drive, Hastings MI 49058  
 Telephone: 269-945-9501 Technical Services: 877-384-5464 Fax: 269-818-1680 Email: techsvcs@vikingcorp.com  
 Visit the Viking website for the latest edition of this technical data page [www.vikinggroupinc.com](http://www.vikinggroupinc.com)

## 5. SYSTEM OPERATION

### 5.1 In the SET condition:

System water supply pressure enters the priming chamber of the deluge valve through the priming line, which includes a normally open priming valve (A), strainer (B), restricted orifice (not shown), check valve (C) and also stops at the inlet of the normally closed PORV (D). In the SET condition, water supply pressure is trapped in the priming chamber by check valve (C), normally closed solenoid valve (E), and the emergency release (F). The pressure in the priming chamber holds the Deluge Valve clapper closed, keeping the outlet chamber and system piping dry.

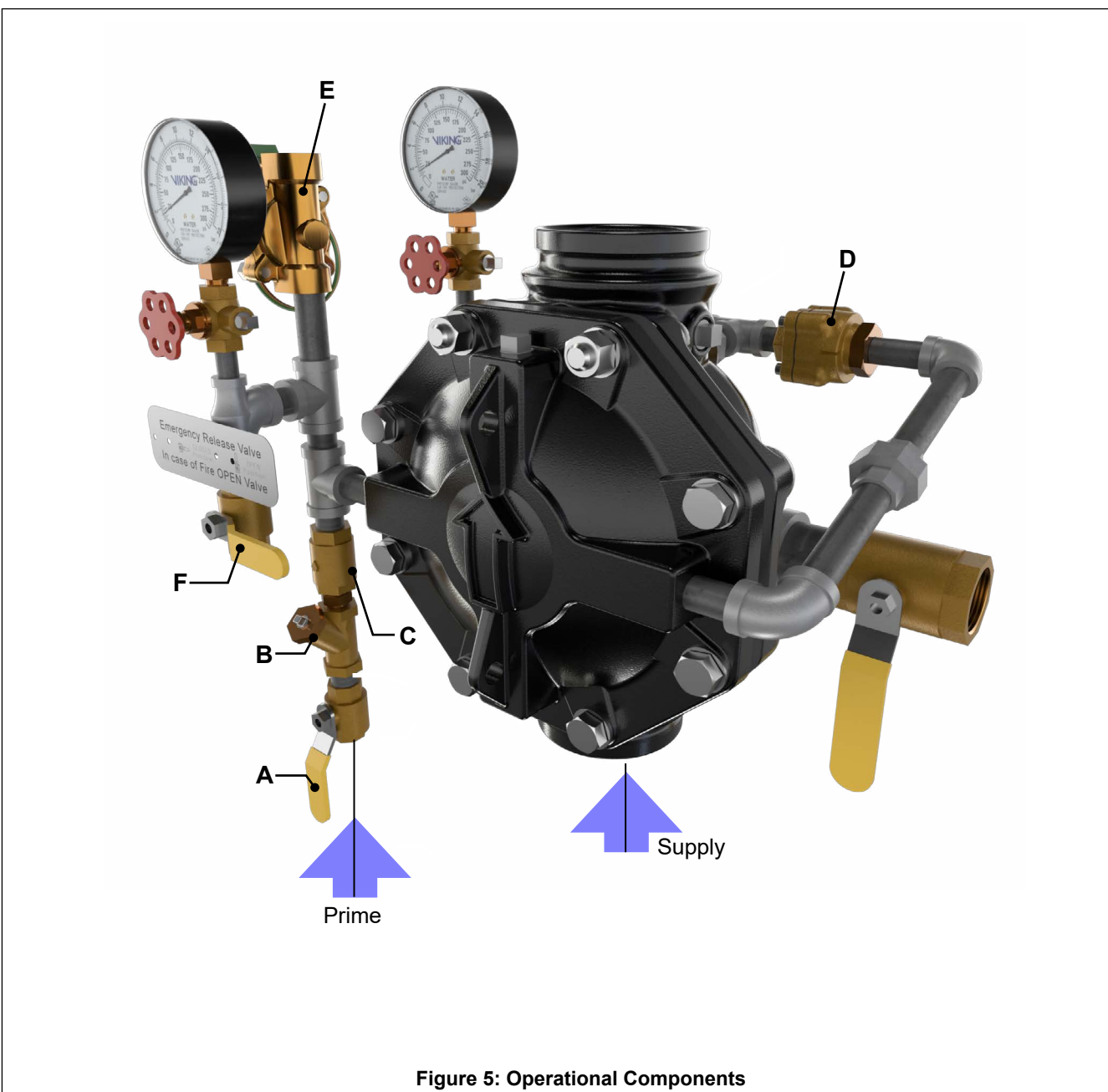

Figure 5: Operational Components



## TECHNICAL DATA

### MODEL VXD DELUGE SYSTEM WITH ELECTRIC RELEASE

The Viking Corporation, 210 N Industrial Park Drive, Hastings MI 49058  
 Telephone: 269-945-9501 Technical Services: 877-384-5464 Fax: 269-818-1680 Email: techsvcs@vikingcorp.com  
 Visit the Viking website for the latest edition of this technical data page [www.vikinggroupinc.com](http://www.vikinggroupinc.com)

#### 5.2 In fire conditions:

When the detection system operates, the system release control panel activates an alarm and energizes the normally closed solenoid valve (E) open. Pressure is released from the priming chamber faster than it is supplied through the restricted orifice. The Deluge Valve diaphragm opens to allow water to flow into the system piping and alarm devices, causing the water motor alarm and water flow alarms connected to the alarm pressure switch (not shown) to activate. Water will flow from any open sprinklers and/or spray nozzles on the system. When the deluge valve operates, water is drained from the PORV inlet. When the 10:1 differential is overcome, the push rod opens, allowing the prime water to drain. If a release resets, priming water will continue to escape through the PORV, allowing the deluge valve to continue to operate until the system is reset. The Deluge Valve can only be reset after the system is taken out of service, and the outlet chamber of the deluge valve and associated trim piping are de-pressurized and drained.

#### 5.3 In trouble conditions:

If the detection system operates due to mechanical damage or malfunction, the Deluge Valve will open. Water will flow from any open sprinklers and/or spray nozzles on the system. The water motor alarm and alarms connected to alarm pressure switch will activate.

#### 5.4 Manual operation:

Anytime the emergency release is pulled, pressure is released from the priming chamber and the deluge valve will open. Water will flow into the system piping and alarm devices. Water will flow from any open sprinklers and/or spray nozzles on the system.

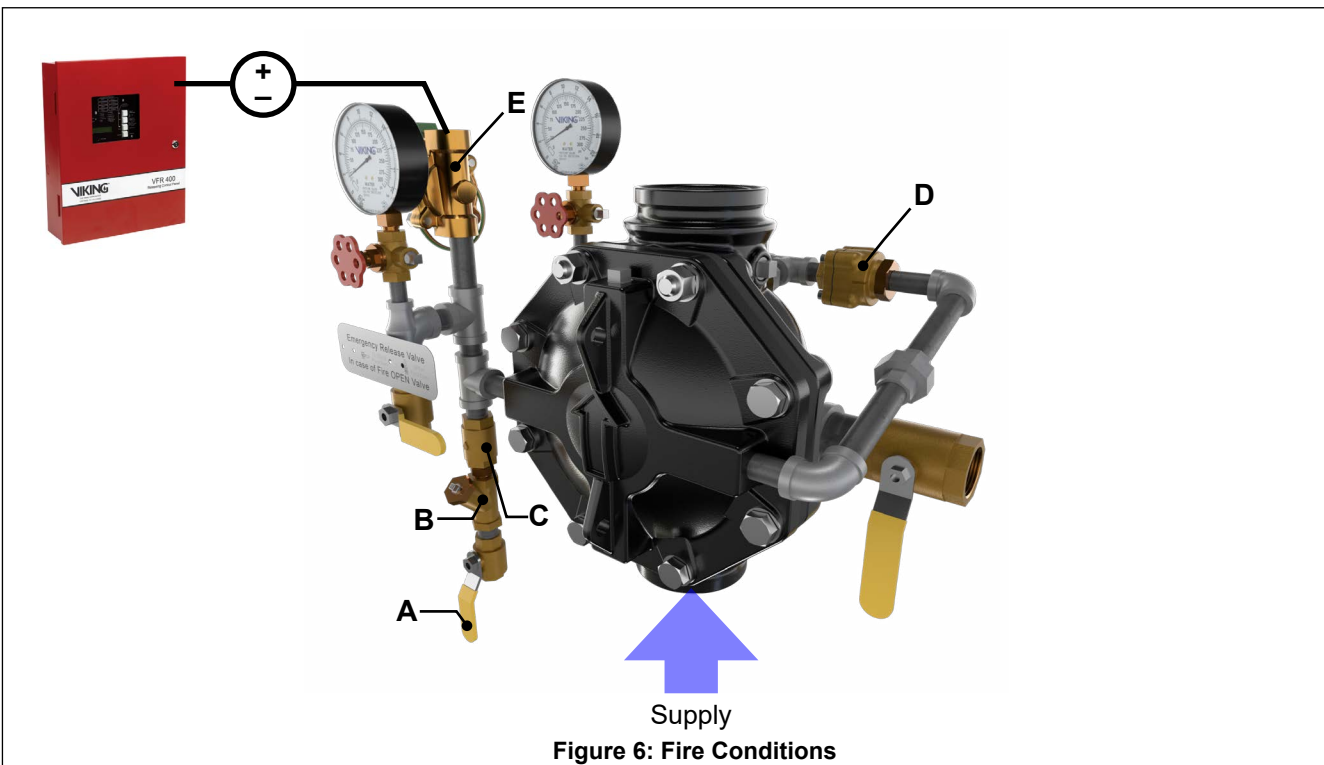

## 6. INSTALLATION

Refer to current Viking Technical Data describing individual components of the Viking VXD Deluge System. Also, refer to applicable installation standards, codes, and Authorities Having Jurisdiction.

1. The valve and trim must be installed only in areas where they will not be subjected to freezing temperatures.
2. Alarm pressure switch should activate when pressurized to 4 to 8 PSI (.3 to .6 bar) on pressure rise. Alarm pressure switch should be wired to activate the waterflow alarm.
3. All initiating devices (detectors), indicating appliances, releasing devices, and the system release control panel must be compatible and approved for use with the deluge system that is used. Refer to appropriate Fire Protection Equipment Approval Guides and current Viking Technical Data describing individual components of the Viking Deluge System that is used.



## TECHNICAL DATA

### MODEL VXD DELUGE SYSTEM WITH ELECTRIC RELEASE

The Viking Corporation, 210 N Industrial Park Drive, Hastings MI 49058  
 Telephone: 269-945-9501 Technical Services: 877-384-5464 Fax: 269-818-1680 Email: techsvcs@vikingcorp.com  
 Visit the Viking website for the latest edition of this technical data page [www.vikinggroupinc.com](http://www.vikinggroupinc.com)

## 7. PLACING THE SYSTEM IN SERVICE

1. Verify the following:
  - The system main water supply control valve (not shown) is closed.
  - The system has been properly drained.
  - The emergency release (F) is closed.
  - The system water supply piping is pressurized up to the closed main water supply control valve and the priming line is pressurized up to the closed priming valve.
2. Open the priming valve (A).
3. Reset the system release control panel. For Viking Model VFR400 Panel, open the panel and press "RESET". The solenoid valve (E) should close. Flow from the solenoid valve to the drain cup should stop.
4. Open flow test valve (G).
5. Slowly and partially open main water supply control valve (not shown).  
**NOTE: Opening the main water supply valve too quickly can create excessive pressure causing the valve to trip.**
6. When full flow develops from the flow test valve (G), close the valve. Verify that there is no flow from the open orifice.
7. Fully open and secure the main water supply control valve.
8. Verify that all valves are in their normal operating position.
9. Verify that no water is discharging into the drain cup.
10. Check for, and repair all leaks.
11. On new installations, those systems that have been placed out of service, or where new equipment has been installed, trip test the system to verify that all equipment functions properly. Refer to Annual Trip Tests, section 9.2 C.
12. After completing a trip test, perform semi-annual maintenance. Refer to section 9.3.B.

### **CAUTION**

Performing a trip test results in operation of the Deluge Valve. Water will flow into the sprinkler piping. Take necessary precautions to prevent damage.

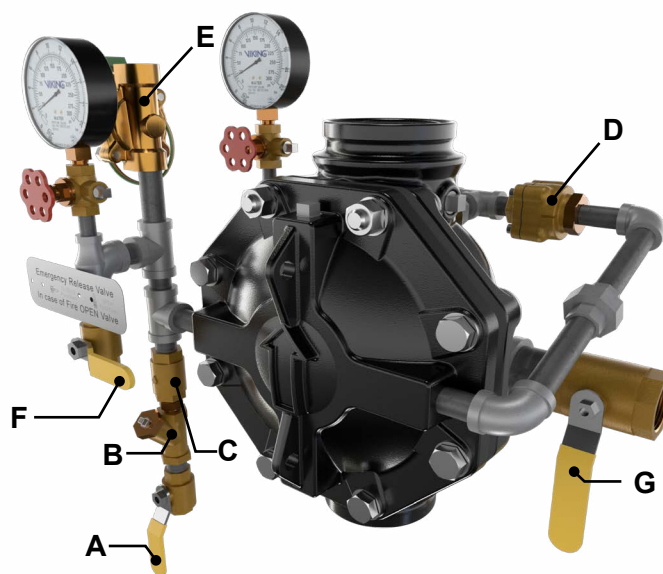

Figure 7: Placing the System in Service



## TECHNICAL DATA

### MODEL VXD DELUGE SYSTEM WITH ELECTRIC RELEASE

The Viking Corporation, 210 N Industrial Park Drive, Hastings MI 49058  
 Telephone: 269-945-9501 Technical Services: 877-384-5464 Fax: 269-818-1680 Email: techsvcs@vikingcorp.com  
 Visit the Viking website for the latest edition of this technical data page [www.vikinggroupinc.com](http://www.vikinggroupinc.com)

## 8. EMERGENCY INSTRUCTIONS

To take system out of service (Refer to Figure 7):

### ⚠ WARNING

**WARNING:** Placing a control valve or detection system out of service may eliminate the fire protection capabilities of the system. Prior to proceeding, notify all Authorities Having Jurisdiction (AHJ). Consideration should be given to employment of a fire patrol in the affected areas.

Refer to the appropriate technical data page and NFPA standards for complete care, handling, installation, and maintenance instructions. For additional product and system information, Viking data pages and installation instructions are available on the Viking Web site at [www.vikinggroupinc.com](http://www.vikinggroupinc.com).

After a fire, verify that the fire is OUT and that placing the system out of service has been authorized by the appropriate Authority Having Jurisdiction.

1. Close the water supply control valve (not shown).  
**NOTE: Sprinkler systems that have been subjected to a fire must be returned to service as soon as possible. The entire system must be inspected for damage, and repaired or replaced as necessary.**
2. Close the priming valve (A).
3. Replace any detectors that have been damaged.
4. Replace any sprinklers and/or spray nozzles that have been damaged or have been exposed to fire conditions.
5. Perform all maintenance procedures recommended in Technical Data describing individual components of the system that have operated.
6. Return the system to service as soon as possible. Refer to section 7: Placing the System In Service.

## 9. INSPECTIONS, TESTS, AND MAINTENANCE

### ⚠ WARNING

Any system maintenance that involves placing a control valve or detection system out of service may eliminate the fire protection capabilities of that system. Prior to proceeding, notify all Authorities Having Jurisdiction. Consideration should be given to employment of a fire patrol in the affected areas.

### ⚠ WARNING

**Risk of death or serious injury.** Having the system out of service may lead to a situation that could cause death or serious injury. If the coil to the monitored solenoid valve is removed, the release control panel will provide a supervisory alarm and the system will be out of service. The solenoid valve must have the coil connected for the system to remain in service.

- Contact the manufacturer, ASCO, or refer to the manufacturer's documentation for more information.

### NOTICE

**The owner is responsible for maintaining the fire protection system and devices in proper operating condition.**

It is imperative that the system be inspected and tested on a regular basis in accordance with NFPA 25. Refer to current Viking Technical Data describing individual components.

The frequency of the inspections may vary due to contaminated water supplies, corrosive water supplies, and corrosive atmospheres. For minimum maintenance and inspection requirements, refer to NFPA 25. In addition, the Authority Having Jurisdiction may have additional maintenance, testing, and inspection requirements that must be followed.



## TECHNICAL DATA

### MODEL VXD DELUGE SYSTEM WITH ELECTRIC RELEASE

The Viking Corporation, 210 N Industrial Park Drive, Hastings MI 49058  
 Telephone: 269-945-9501 Technical Services: 877-384-5464 Fax: 269-818-1680 Email: techsvcs@vikingcorp.com  
 Visit the Viking website for the latest edition of this technical data page [www.vikinggroupinc.com](http://www.vikinggroupinc.com)

## 9.1 Inspection

### Weekly - Viking recommends a weekly visual inspection; check the following items.

- Verify that the main water supply control valve is open and that all other valves are in their normal operating position and appropriately secured.
- Check for signs of mechanical damage, leakage, and/or corrosive activity. If detected, perform maintenance as required. If necessary, replace the device.
- Verify that the valve and trim are adequately heated and protected from freezing and physical damage.

**NOTE: For normal operating position, refer to Figure 4.**

## 9.2 Periodic System Tests

### A. Quarterly Water Flow Alarm Test

1. Notify the Authority Having Jurisdiction and those in the area affected by the test.
2. To test the local electric alarm (if provided) and/or mechanical water motor alarm (if provided), OPEN the alarm test valve in the Deluge Valve trim.
  - a. Electric alarm pressure switches (if provided) should activate.
  - b. Electric local alarms should be audible.
  - c. The local water motor gong should be audible.
  - d. If equipped with remote station alarm signaling devices, verify that alarm signals were received.
3. When testing is complete, CLOSE the Alarm Test Valve.
4. Verify the following:
  - a. All local alarms stop sounding and alarm panels (if provided) reset.
  - b. All remote station alarms reset.
  - c. Supply piping to water motor alarm properly drains.
5. Verify that the Alarm Test Valve is CLOSED.
6. Verify that the outlet chamber is free of water. No water should flow from the alarm drain line.
7. Notify the Authority Having Jurisdiction and those in the affected area that testing is complete.

### B. Quarterly Main Drain Test

1. Notify the Authority Having Jurisdiction and those in the area affected by the test.
2. Record pressure reading from the water supply pressure gauge.
3. Verify that the outlet chamber of the Deluge Valve is free of water. No water should flow from the alarm drain line.
4. Fully OPEN the Flow Test Valve.
5. When a full flow is developed from the Flow Test Valve, record the residual pressure from the water supply pressure gauge.
6. When the test is complete, SLOWLY CLOSE the Flow Test Valve.
7. Compare test results with previous flow information. If deterioration of the water supply is detected, take appropriate steps to restore adequate water supply.
8. Verify:
  - a. Normal water supply pressure has been restored to the inlet chamber, the priming chamber, and the release system. The pressure on the priming chamber water pressure gauge should equal the system water supply pressure.
  - b. All alarm devices and valves are secured in normal operating position (refer to Figure 5).
9. Notify the Authority Having Jurisdiction that the test is complete. Record and/or provide notification of test results as required by the Authority Having Jurisdiction.

### C. Annual Trip Test

#### **⚠ CAUTION**

**Performing this test results in operation of the Deluge Valve. Water will flow into the sprinkler piping and from any open sprinklers and/or nozzles. Take necessary precautions to prevent damage.**

1. Notify the Authority Having Jurisdiction and those in the area affected by the test.
2. Fully open the Flow Test Valve to flush away any accumulation of foreign material.
3. Close the Flow Test Valve.
4. Trip the system by operating the release system. Allow a full flow to pass through the Deluge Valve. Water flow alarms should operate.

**TECHNICAL DATA****MODEL VXD DELUGE SYSTEM  
WITH ELECTRIC RELEASE**

The Viking Corporation, 210 N Industrial Park Drive, Hastings MI 49058  
Telephone: 269-945-9501 Technical Services: 877-384-5464 Fax: 269-818-1680 Email: techsvcs@vikingcorp.com  
Visit the Viking website for the latest edition of this technical data page [www.vikinggroupinc.com](http://www.vikinggroupinc.com)

5. When test is complete:
  - a. Close the Main Water Supply Control Valve.
  - b. Close the Priming Valve.
  - c. Open all system main drains. Allow the system to drain completely.
6. Perform semi-annual maintenance. Refer to section 9.3.B: Semi-Annual Maintenance.
7. Place the system in service. Refer to section 7.
8. Notify the Authority Having Jurisdiction that the test is complete. Record and/or provide notification of test results as required by the Authority Having Jurisdiction.

### 9.3 Maintenance

#### A. After Each Operation:

1. Sprinkler systems that have been subjected to a fire must be returned to service as soon as possible. The entire system must be inspected for damage, and repaired or replaced as necessary.
2. Deluge Valves and trim that have been subjected to brackish water, salt water, foam/water solution, or any other corrosive water supply, should be flushed with good quality fresh water before being returned to service.
3. Perform semi-annual maintenance after every operation.

#### B. Semi-Annually:

1. Remove the system from service.
2. Close the Main Water Supply Control Valve and Priming Valve.
3. Relieve pressure in the priming chamber by opening the emergency release Valve.
4. Inspect all trim for signs of corrosion and/or blockage. Clean and/or replace as required.
5. Clean and/or replace all strainer screens.
6. Refer to section 7: Placing the System in Service.

#### C. Every Fifth Year:

1. Internal inspection of Deluge Valves is recommended every five years unless inspections and tests indicate more frequent internal inspections are required. Refer to the Model VXD Valve Technical Data Page.
2. Internal inspection of strainers, and restricted orifices is recommended every five years unless inspections and tests indicate more frequent internal inspections are required.
3. Record and provide notification of inspection results as required by the Authority Having Jurisdiction.



# TECHNICAL DATA

## MODEL VXD DELUGE SYSTEM WITH ELECTRIC RELEASE

The Viking Corporation, 210 N Industrial Park Drive, Hastings MI 49058  
 Telephone: 269-945-9501 Technical Services: 877-384-5464 Fax: 269-818-1680 Email: techsvcs@vikingcorp.com  
 Visit the Viking website for the latest edition of this technical data page [www.vikinggroupinc.com](http://www.vikinggroupinc.com)

### 10. DIMENSIONS

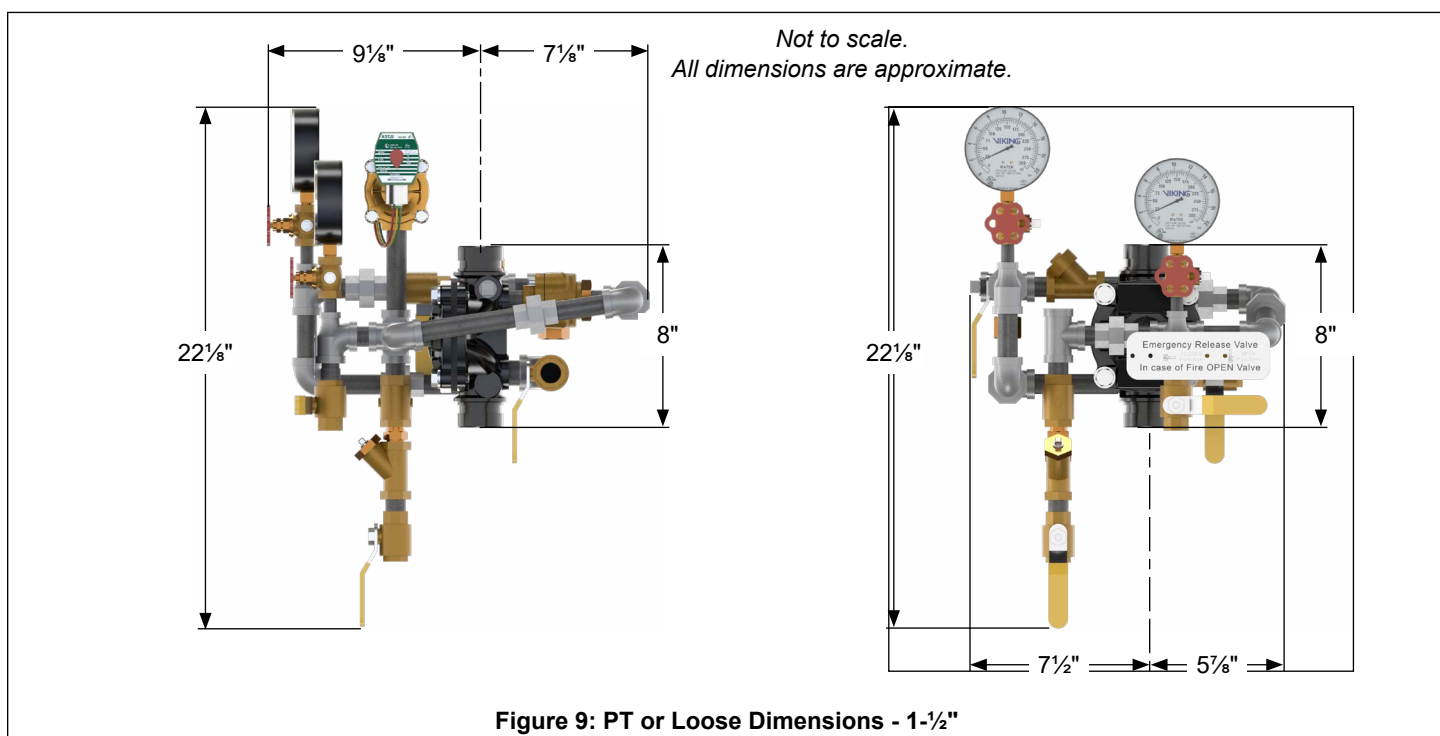
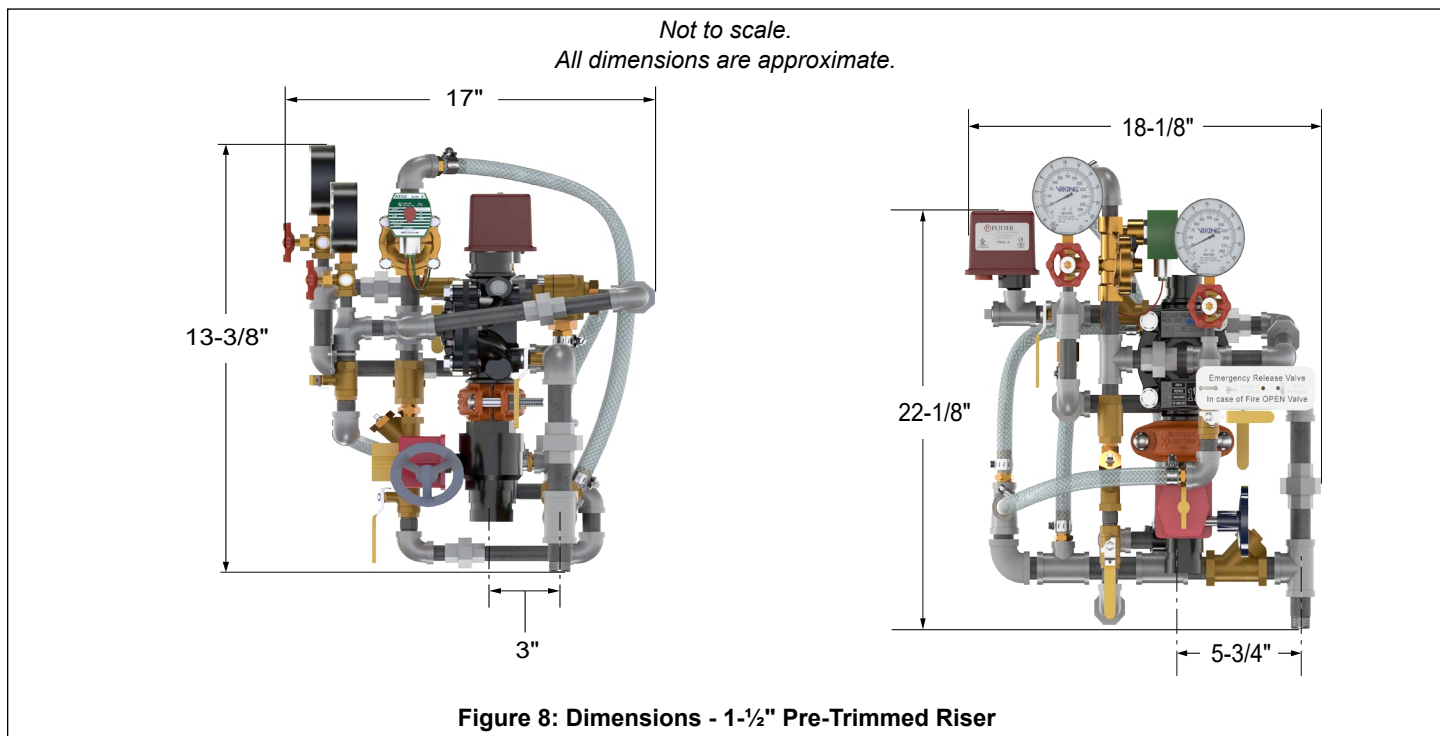



# TECHNICAL DATA

## MODEL VXD DELUGE SYSTEM WITH ELECTRIC RELEASE

The Viking Corporation, 210 N Industrial Park Drive, Hastings MI 49058  
 Telephone: 269-945-9501 Technical Services: 877-384-5464 Fax: 269-818-1680 Email: techsvcs@vikingcorp.com  
 Visit the Viking website for the latest edition of this technical data page [www.vikinggroupinc.com](http://www.vikinggroupinc.com)

Not to scale.  
 All dimensions are approximate.

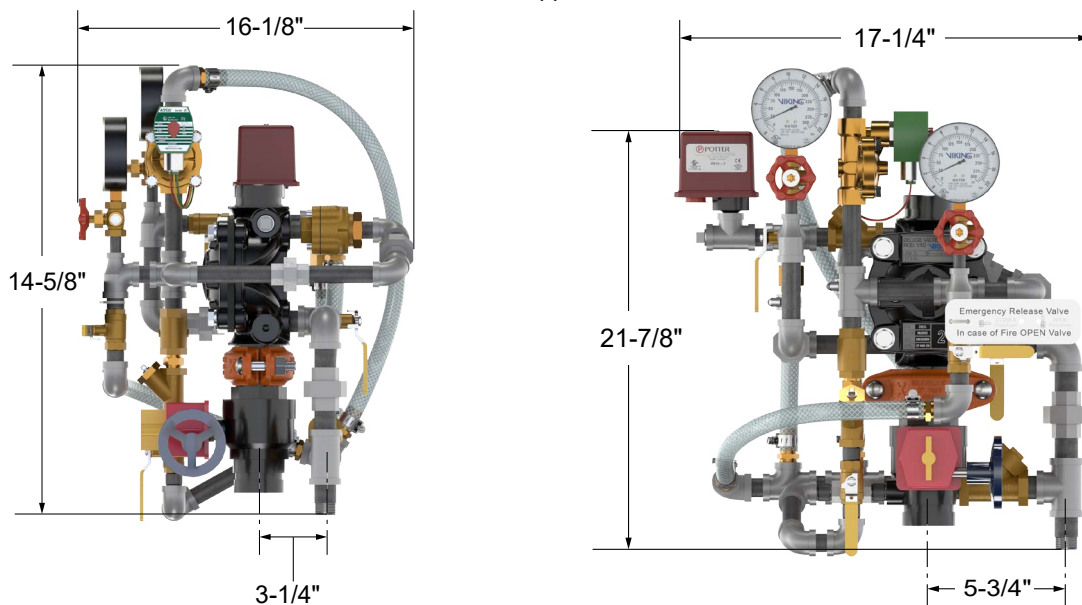

Figure 10: Pre-Trimmed Riser Dimensions - 2"

Not to scale.  
 All dimensions are approximate.

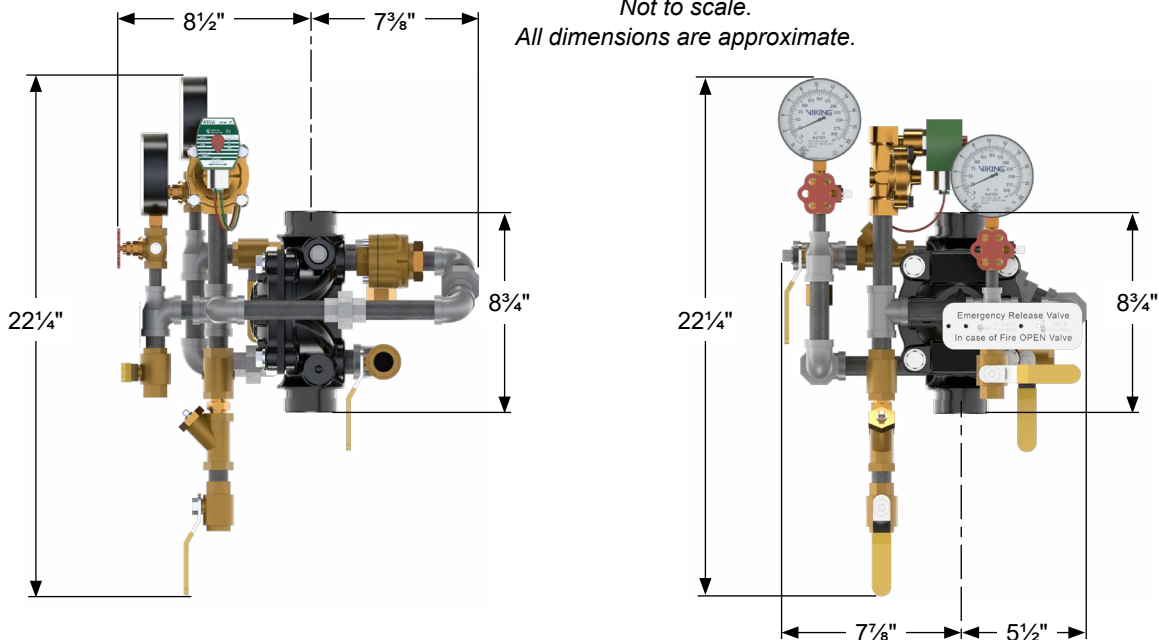

Figure 11: PT or Loose Dimensions - 2"



# TECHNICAL DATA

## MODEL VXD DELUGE SYSTEM WITH ELECTRIC RELEASE

The Viking Corporation, 210 N Industrial Park Drive, Hastings MI 49058  
 Telephone: 269-945-9501 Technical Services: 877-384-5464 Fax: 269-818-1680 Email: techsvcs@vikingcorp.com  
 Visit the Viking website for the latest edition of this technical data page [www.vikinggroupinc.com](http://www.vikinggroupinc.com)

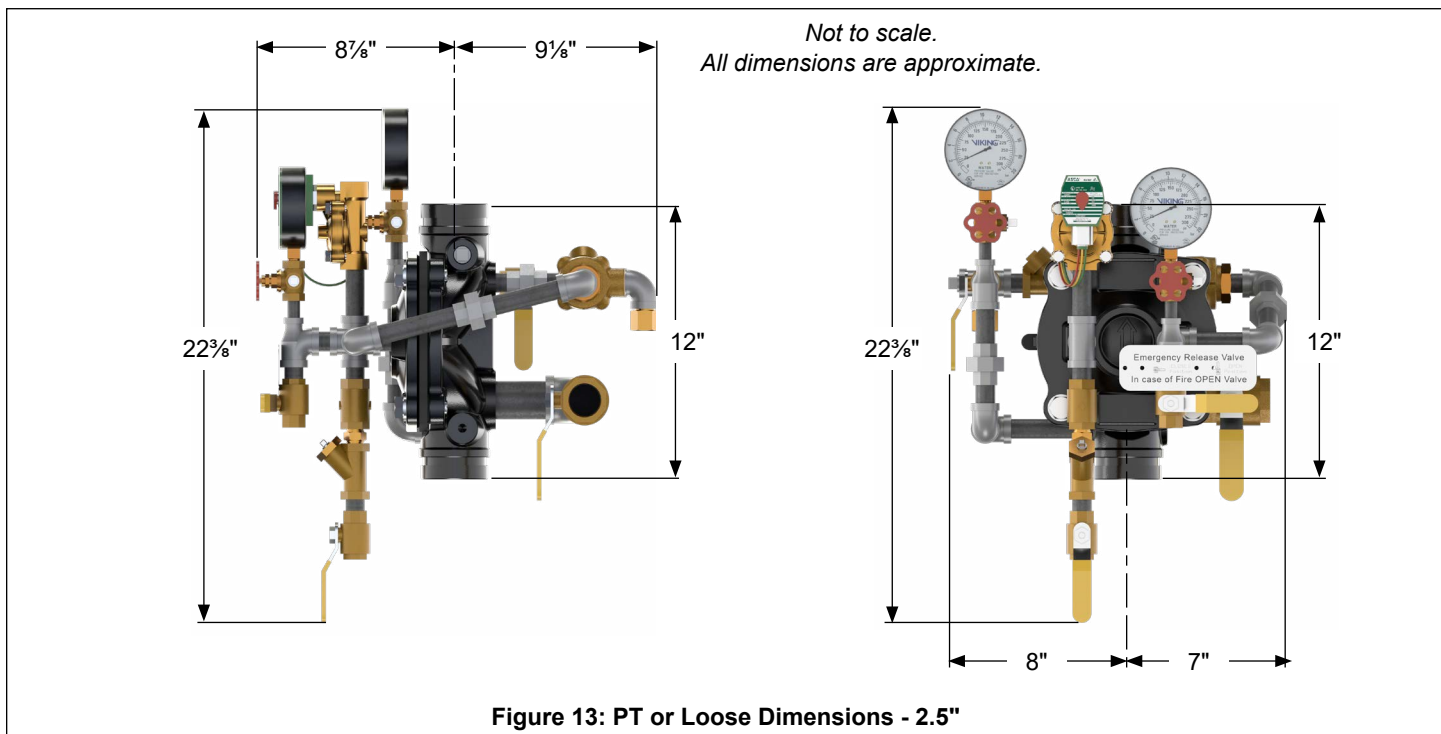
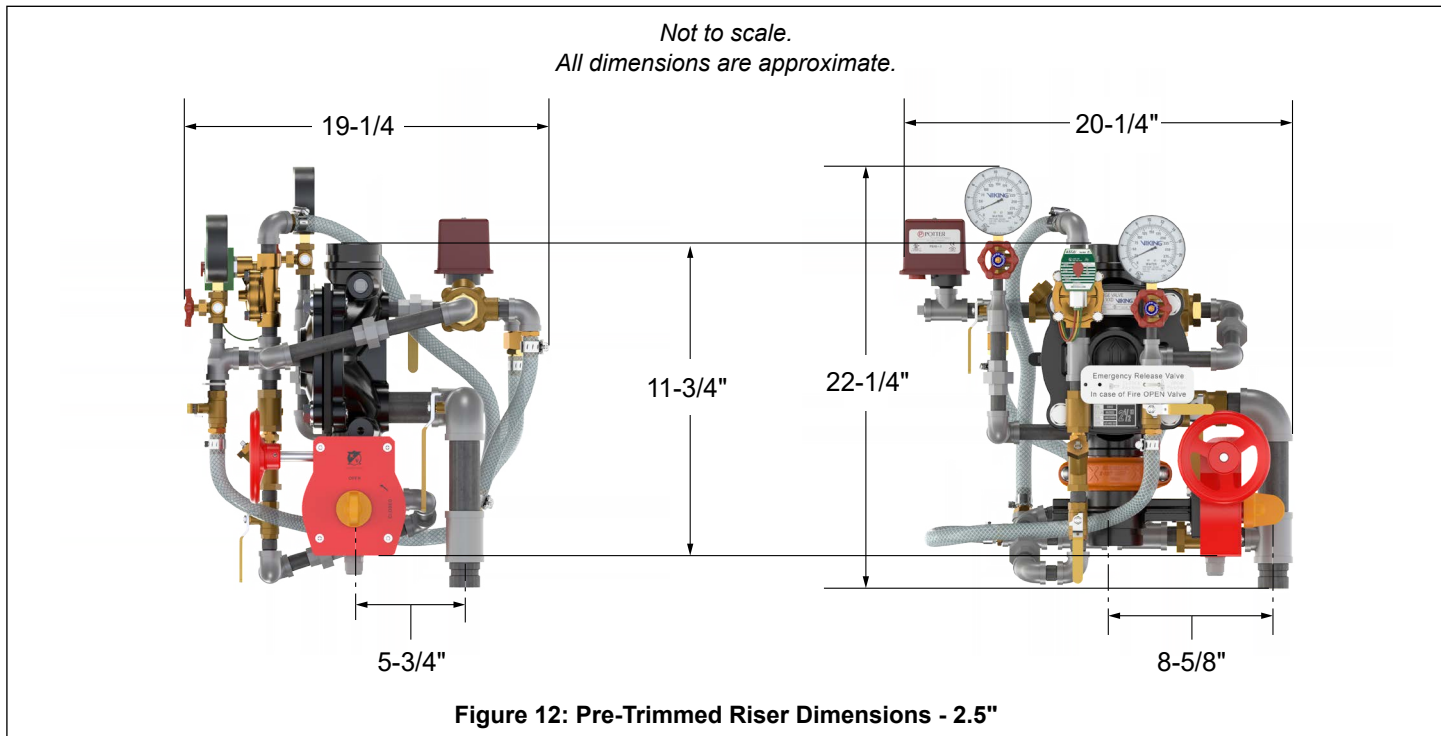



# TECHNICAL DATA

## MODEL VXD DELUGE SYSTEM WITH ELECTRIC RELEASE

The Viking Corporation, 210 N Industrial Park Drive, Hastings MI 49058  
 Telephone: 269-945-9501 Technical Services: 877-384-5464 Fax: 269-818-1680 Email: techsvcs@vikingcorp.com  
 Visit the Viking website for the latest edition of this technical data page [www.vikinggroupinc.com](http://www.vikinggroupinc.com)

*Not to scale.  
 All dimensions are approximate.*

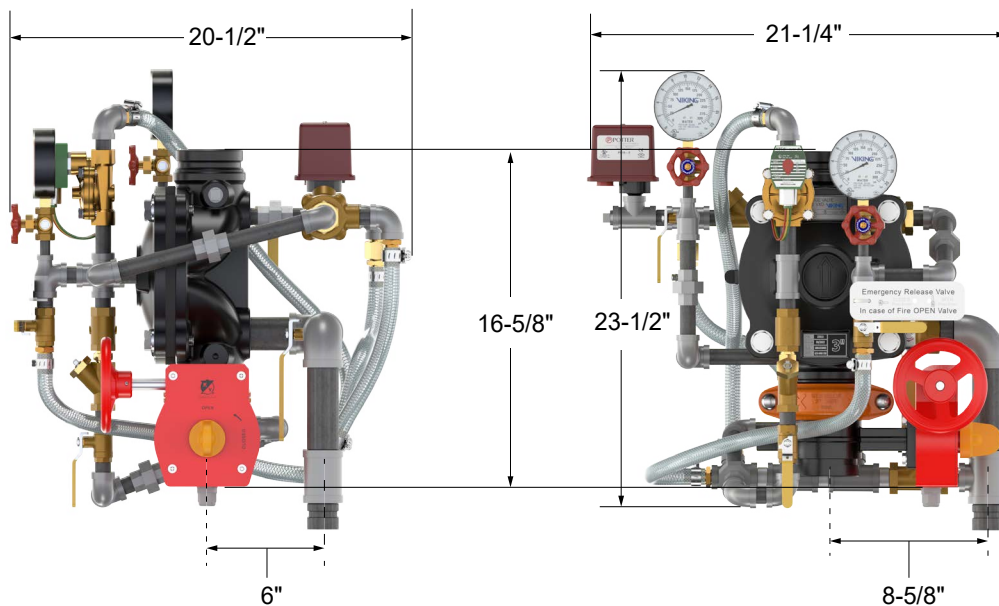

**Figure 14: Pre-Trimmed Riser Dimensions - 3"**

*Not to scale.  
 All dimensions are approximate.*

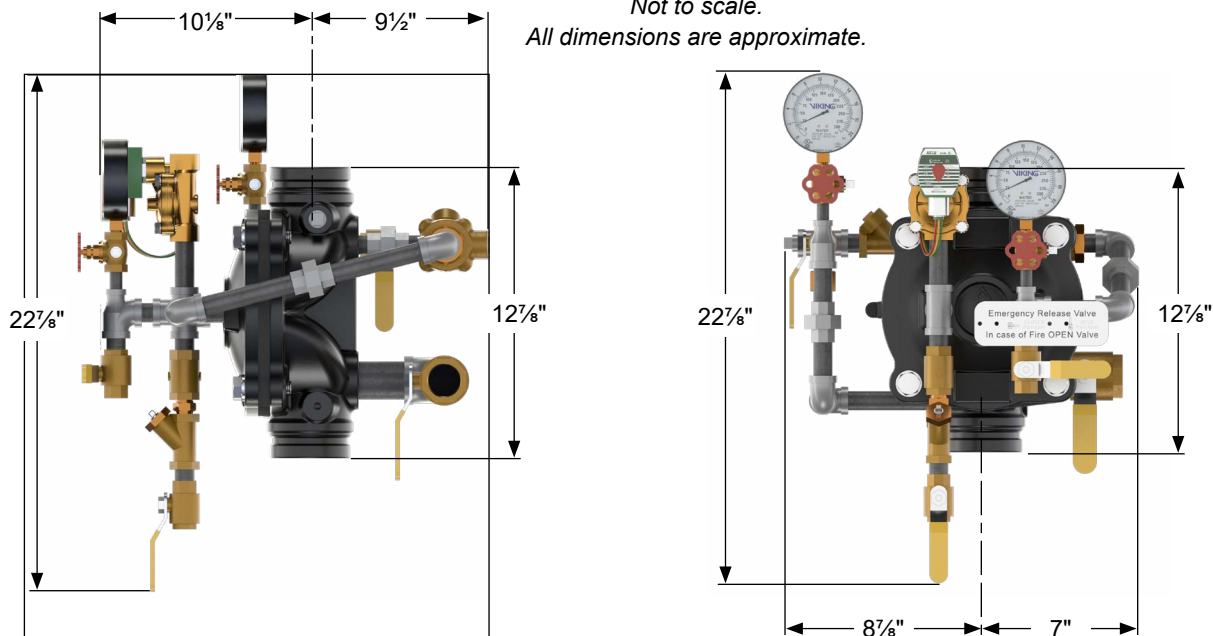

**Figure 15: PT or Loose Dimensions - 3"**



# TECHNICAL DATA

## MODEL VXD DELUGE SYSTEM WITH ELECTRIC RELEASE

The Viking Corporation, 210 N Industrial Park Drive, Hastings MI 49058  
 Telephone: 269-945-9501 Technical Services: 877-384-5464 Fax: 269-818-1680 Email: techsvcs@vikingcorp.com  
 Visit the Viking website for the latest edition of this technical data page [www.vikinggroupinc.com](http://www.vikinggroupinc.com)

*Not to scale.  
 All dimensions are approximate.*

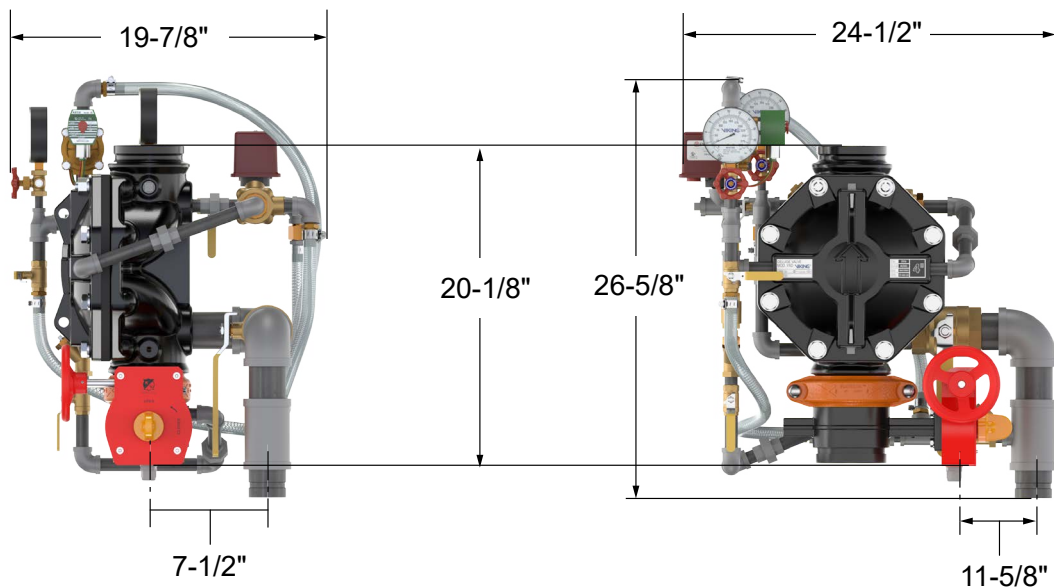

**Figure 16: Pre-Trimmed Riser Dimensions - 4"**

*Not to scale.  
 All dimensions are approximate.*

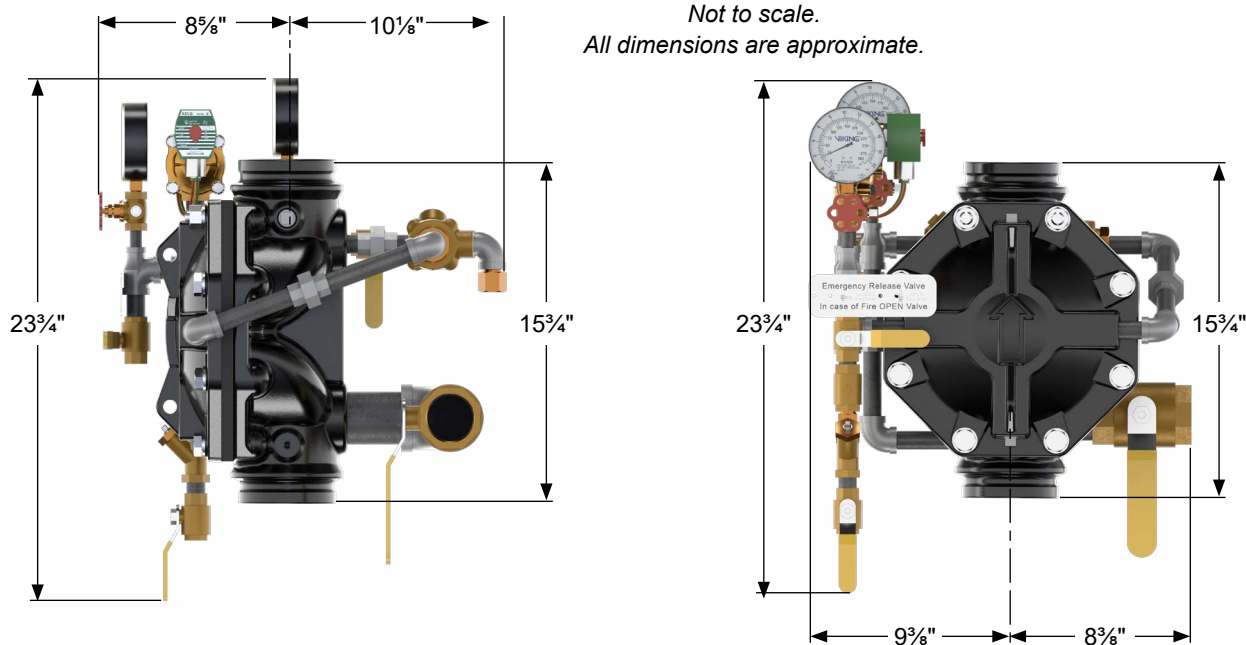

**Figure 17: PT or Loose Dimensions - 4"**



# TECHNICAL DATA

## MODEL VXD DELUGE SYSTEM WITH ELECTRIC RELEASE

The Viking Corporation, 210 N Industrial Park Drive, Hastings MI 49058  
 Telephone: 269-945-9501 Technical Services: 877-384-5464 Fax: 269-818-1680 Email: techsvcs@vikingcorp.com  
 Visit the Viking website for the latest edition of this technical data page [www.vikinggroupinc.com](http://www.vikinggroupinc.com)

*Not to scale.  
 All dimensions are approximate.*

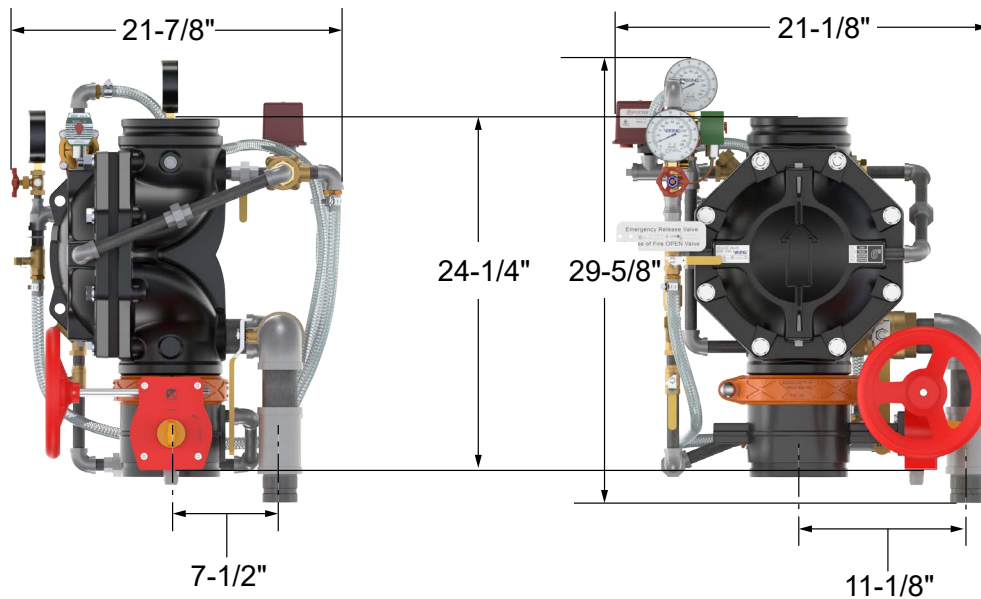

**Figure 18: Pre-Trimmed Riser Dimensions - 6"**

*Not to scale.  
 All dimensions are approximate.*

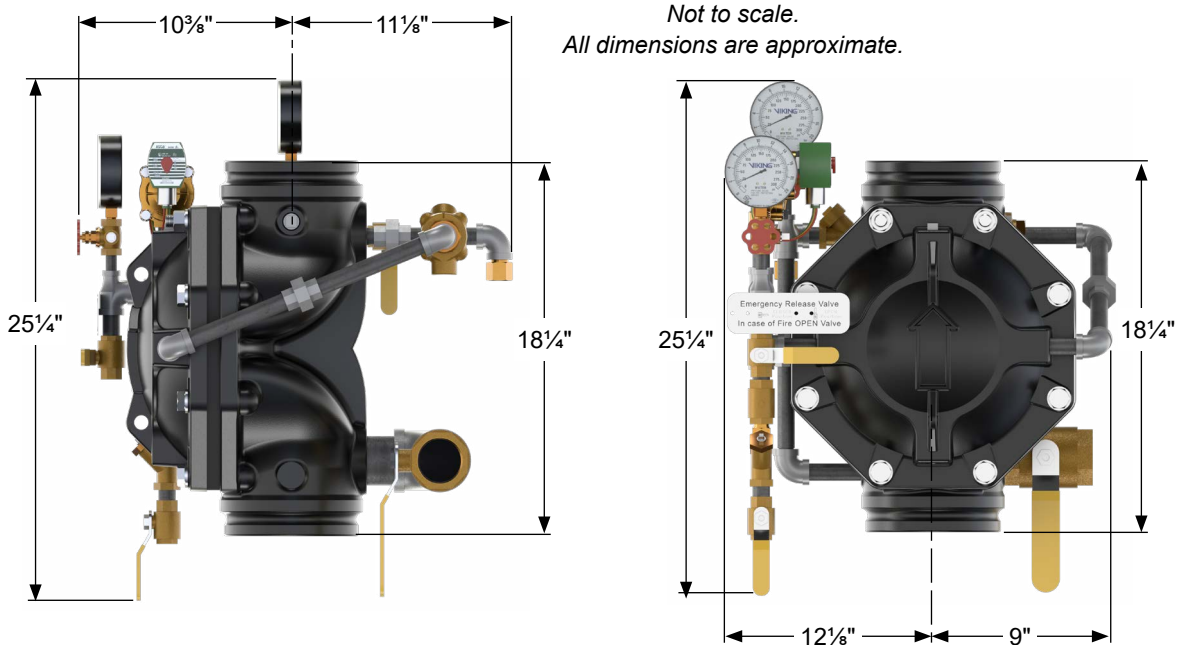

**Figure 19: PT or Loose Dimensions - 6"**



# TECHNICAL DATA

## MODEL VXD DELUGE SYSTEM WITH ELECTRIC RELEASE

The Viking Corporation, 210 N Industrial Park Drive, Hastings MI 49058  
 Telephone: 269-945-9501 Technical Services: 877-384-5464 Fax: 269-818-1680 Email: techsvcs@vikingcorp.com  
 Visit the Viking website for the latest edition of this technical data page [www.vikinggroupinc.com](http://www.vikinggroupinc.com)

*Not to scale.  
 All dimensions are approximate.*

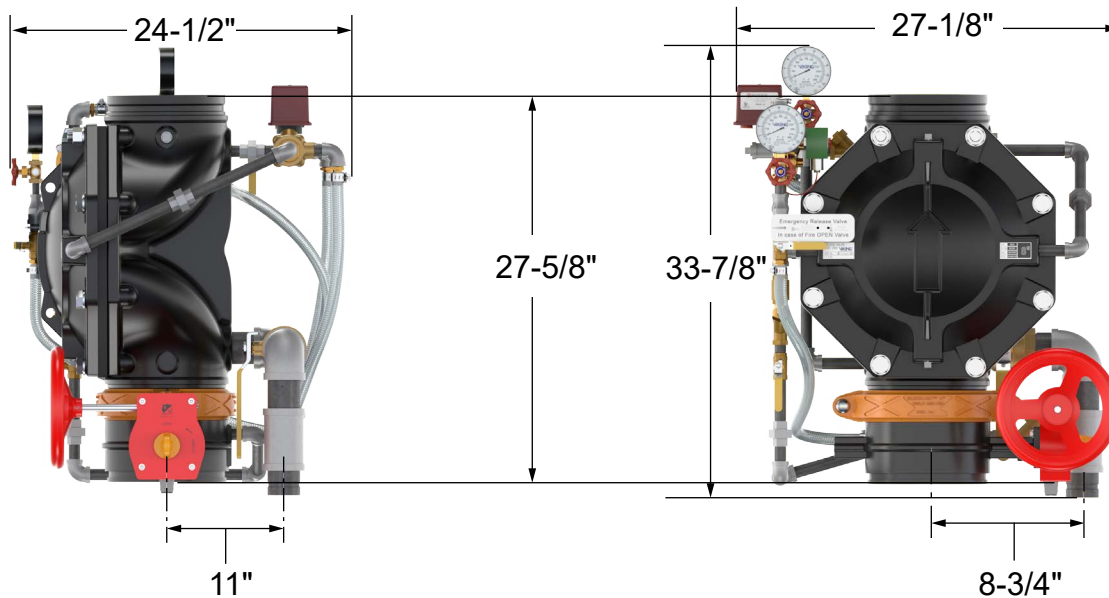

**Figure 20: Pre-Trimmed Riser Dimensions - 8"**

*Not to scale.  
 All dimensions are approximate.*

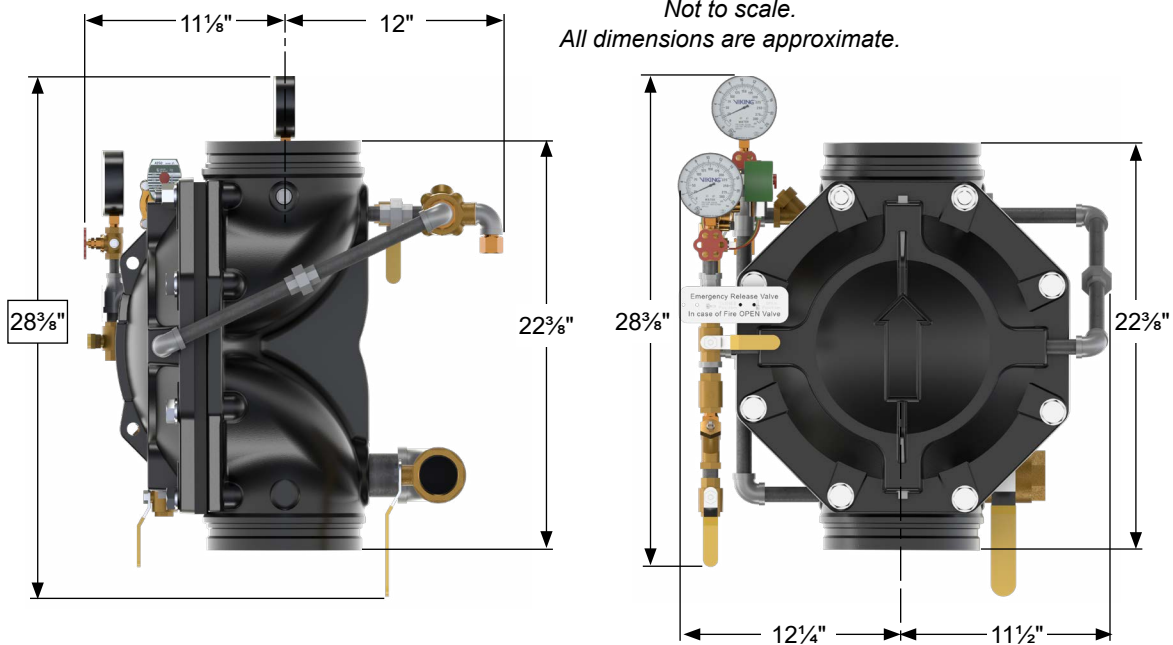

**Figure 21: PT or Loose Dimensions - 8"**



# TECHNICAL DATA

## MODEL VXD DELUGE SYSTEM WITH ELECTRIC RELEASE

The Viking Corporation, 210 N Industrial Park Drive, Hastings MI 49058  
 Telephone: 269-945-9501 Technical Services: 877-384-5464 Fax: 269-818-1680 Email: techsvcs@vikingcorp.com  
 Visit the Viking website for the latest edition of this technical data page [www.vikinggroupinc.com](http://www.vikinggroupinc.com)

