



# TECHNICAL DATA

## MODEL VXD DOUBLE INTERLOCKED PREACTION SYSTEM WITH ELECTRIC/PNEUMATIC RELEASE

The Viking Corporation, 210 N Industrial Park Drive, Hastings MI 49058  
 Telephone: 269-945-9501 Technical Services: 877-384-5464 Fax: 269-818-1680 Email: techsvcs@vikingcorp.com  
 Visit the Viking website for the latest edition of this technical data page [www.vikinggroupinc.com](http://www.vikinggroupinc.com)

### 1. INTRODUCTION

Viking VXD Double-Interlocked Preaction Systems use a Viking Model VXD Deluge Valve that is controlled by a pneumatic actuator. The actuator is normally held closed by the sprinkler system's air/nitrogen that is maintained by a normally-closed electric solenoid valve. In order for the deluge valve to open and fill the system with water, the releasing panel with electric detection system must activate and the air/nitrogen must be relieved from the system. If the electric detection system (alone) operates due to fire, damage, or malfunction, an alarm will activate, but the deluge valve will NOT open. If the sprinkler piping is damaged or a sprinkler is broken or fused, but the detection system has not activated, an alarm will activate but the deluge valve will NOT open. In fire conditions, operation of both the detection system and a sprinkler is required before the deluge valve will open allowing water to enter the system piping.

Electric/Pneumatic double interlocked preaction systems are commonly used as refrigerated area systems, where flooding of the pipe can have serious consequences, and where it is important to control accidental water discharge due to damaged sprinkler piping. Care should be taken since double interlocked preaction systems may not produce flow from opened sprinklers as quickly as single- or non-interlocked preaction systems. Activation of the detection system alone, or operation of a sprinkler alone, will sound an alarm but will NOT cause the system to fill with water.



### 2. LISTINGS AND APPROVALS



**cULus Listed** - Categories VLFT and VLFT7



**FM Approved** - Viking Electric/Pneumatic Double-Interlocked Preaction Systems are FM Approved as refrigerated area systems.



**WARNING:** Cancer and Reproductive Harm-  
[www.P65Warnings.ca.gov](http://www.P65Warnings.ca.gov)

### 3. ORDERING INFORMATION

#### 3.1 Options and Configurations

The Model VXD Double Interlock Preaction System with Electric/Pneumatic Release can be ordered in the following configurations:

- Pre-Trimmed Riser (PTR) assembly - Refer to section 3.2
- Pre-Trimmed (PT) - Refer to section 3.3
- Loose configurations (with the same trim configuration as PT) - Refer to section 3.4

#### Monitored Solenoid Option

Each of the above configurations can be ordered with a monitored or non-monitored release solenoid. The monitored solenoid is a new option, which offers an NFPA 13 solenoid monitoring-compliant solution. For more information, refer to F\_031225.

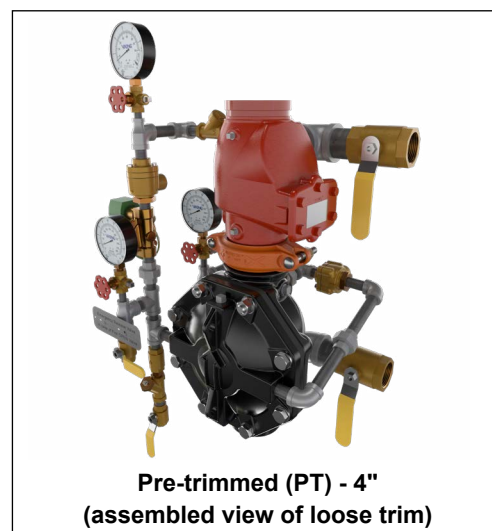



## TECHNICAL DATA

### MODEL VXD DOUBLE INTERLOCKED PREACTION SYSTEM WITH ELECTRIC/PNEUMATIC RELEASE

The Viking Corporation, 210 N Industrial Park Drive, Hastings MI 49058  
 Telephone: 269-945-9501 Technical Services: 877-384-5464 Fax: 269-818-1680 Email: techsvcs@vikingcorp.com  
 Visit the Viking website for the latest edition of this technical data page [www.vikinggroupinc.com](http://www.vikinggroupinc.com)

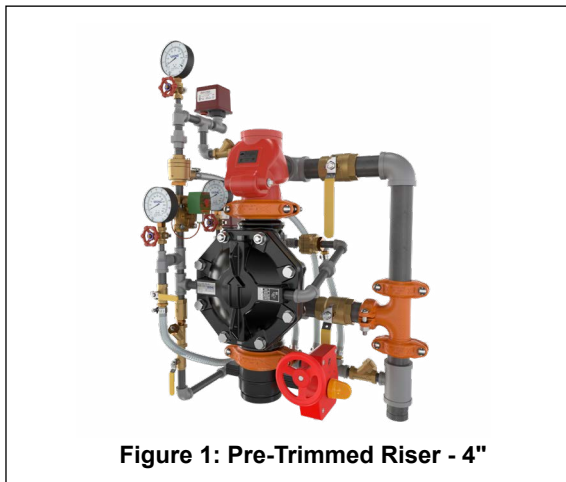

Figure 1: Pre-Trimmed Riser - 4"

### 3.2 Pre-Trimmed Riser (PTR)

Pre-Trimmed Riser packages come completely assembled and ready to install. These packages include the Model VXD deluge valve with trim, a riser check valve, additional components as shown below, and come with galvanized pipe and groove/groove connections only.

The Pre-Trimmed Riser packages include the following components: Model VXD valve

- Riser check valve
- completely assembled trim
- electric release solenoid
- pneumatic actuator
- water supply control valve
- pressure gauges for air and water
- grooved couplings
- water flow and air supervisory pressure switches
- complete drain manifold with hoses and drain cup

**Table 1: Pre-Trimmed Riser (PTR)  
Model VXD Double Interlock Preaction System  
with Electric/Pneumatic Release (Vertical)**

Nominal Size (inch)	Part Numbers <sup>1</sup>	
	Non-Monitored Solenoid	Monitored Solenoid
1½	24891	28137
2	24901	28138
2½	25468	28139
3	25400	28140
4	25415	28141
6	25441	28142
8	25501	28143
10	Not available	Not available

<sup>1</sup> Pre-trimmed riser assemblies include galvanized trim components and grooved pipe connections.



## TECHNICAL DATA

### MODEL VXD DOUBLE INTERLOCKED PREACTION SYSTEM WITH ELECTRIC/PNEUMATIC RELEASE

The Viking Corporation, 210 N Industrial Park Drive, Hastings MI 49058  
 Telephone: 269-945-9501 Technical Services: 877-384-5464 Fax: 269-818-1680 Email: techsvcs@vikingcorp.com  
 Visit the Viking website for the latest edition of this technical data page [www.vikinggroupinc.com](http://www.vikinggroupinc.com)

### 3.3 Pre-trimmed (PT) Assemblies

Pre-trimmed packages come completely assembled and ready to install. These packages include the Model VXD Deluge valve with trim as shown below, a riser check valve, and come with galvanized pipe and groove/groove connections only.

The Pre-trimmed packages include the following components:

- Model VXD valve
- riser check valve
- completely assembled trim
- electric release solenoid
- pneumatic actuator
- pressure gauges for air and water
- loose drain cup

Refer to Table 2 for ordering information.

### 3.4 Loose Trim Packages

**NOTICE: The Model VXD valve must be trimmed as shown on the trim diagrams. Any deviation from trim size or arrangement may affect the proper operation of the valve. Refer to the appropriate trim diagram for the system size and type to be used.**

Loose trim packages come loose in a box and assembly is required. The packages do NOT include the Model VXD valve or a riser check valve, which must be ordered separately. The Model VXD deluge valve can be ordered with flange/flange or groove/groove connections (refer to the Model VXD deluge valve technical data). The loose trim packages can be ordered with galvanized or brass trim, refer to Table 2 below.

These loose trim packages include the following components:

- all required trim components
- electric release solenoid
- pneumatic actuator
- pressure gauges for air and water
- loose drain cup

Refer to the "System Components" for more information.

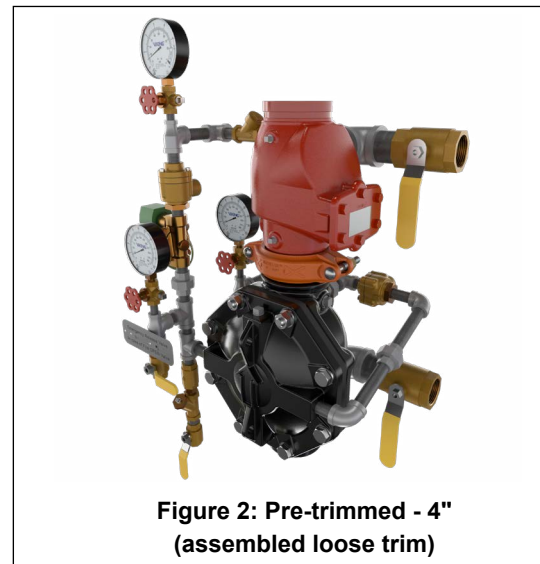

Figure 2: Pre-trimmed - 4"  
(assembled loose trim)

**Table 2: Pre-trimmed (PT) and Loose trim  
Model VXD Double Interlock Preaction System  
with Electric/Pneumatic Release (Vertical)**

Nominal Size	Ordering Information					
	Pre-trimmed		Loose trim <sup>1</sup>			
	Non-Monitored Solenoid	Monitored Solenoid	Non-Monitored Solenoid		Monitored Solenoid	
	Galvanized	Galvanized	Galvanized	Brass	Galvanized	Brass
1-½	23569	28066	23568-1	23568-2	28065-1	28065-2
2	23590	28115	23589-1	23589-2	28114-1	28114-2
2½	23611	28062	23610-1	23610-2	28061-1	28061-2
3	23632	28119	23631-1	23631-2	28118-1	28118-2
4	23654	28049	23653-1	23653-2	28048-1	28048-2
6	23675	28117	23674-1	23674-2	28116-1	28116-2
8	23696	28109	23695-1	23695-2	28108-1	28108-2
10	23757	28122	23756-1	23756-2	28121-1	28121-2

1. Loose trim packages do NOT include the VXD valve or the riser check valve. Refer to the Model VXD Deluge Valve technical data sheet for more information.



# TECHNICAL DATA

## MODEL VXD DOUBLE INTERLOCKED PREACTION SYSTEM WITH ELECTRIC/PNEUMATIC RELEASE

The Viking Corporation, 210 N Industrial Park Drive, Hastings MI 49058  
 Telephone: 269-945-9501 Technical Services: 877-384-5464 Fax: 269-818-1680 Email: techsvcs@vikingcorp.com  
 Visit the Viking website for the latest edition of this technical data page www.vikinggroupinc.com

### 4. SYSTEM COMPONENTS

#### 4.1 VXD Double Interlock PTR Components

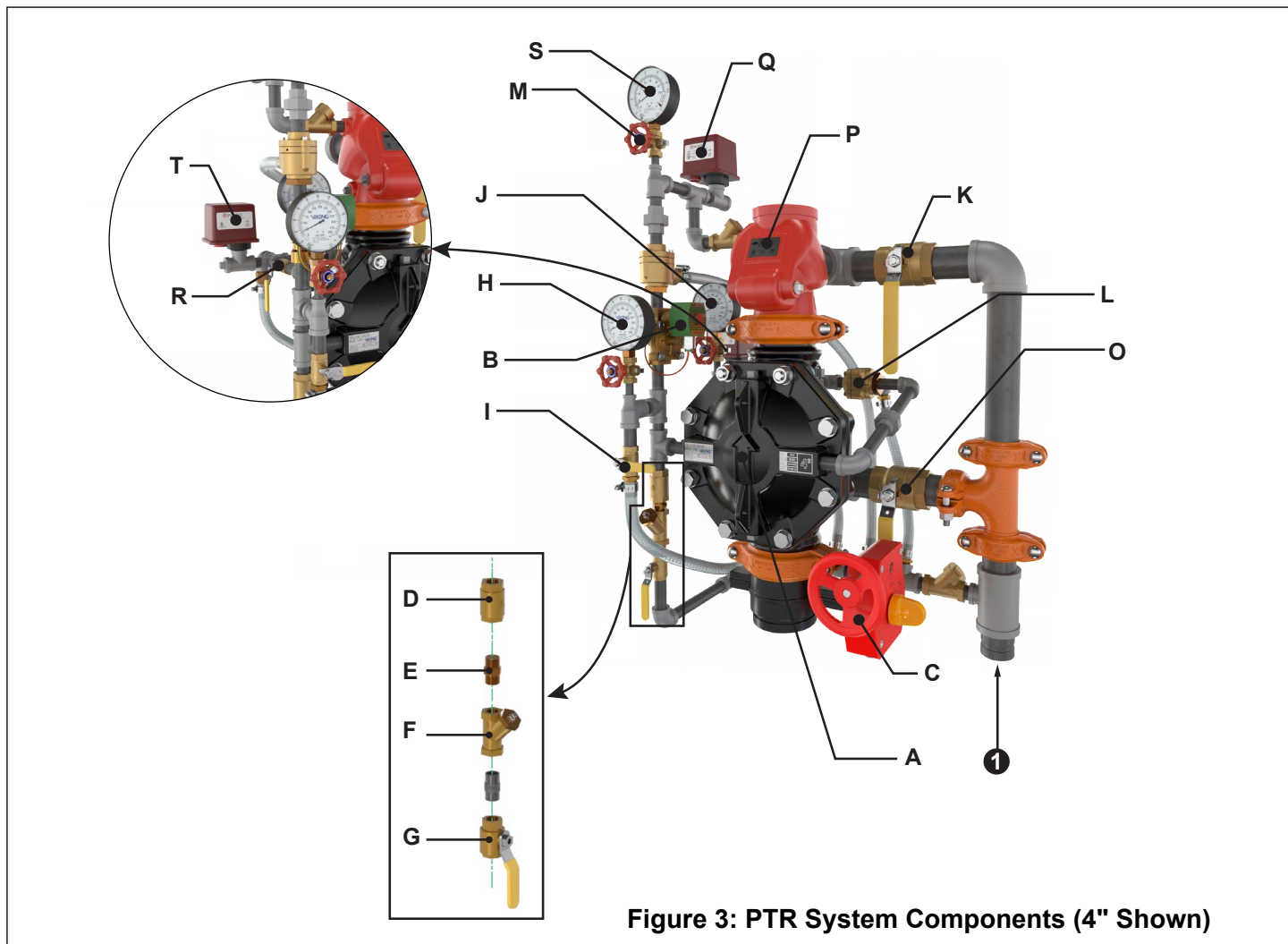

Figure 3: PTR System Components (4" Shown)

Item	Description	Item	Description	Item	Description
A	Deluge valve	H	Prime pressure gauge	O	Flow test valve (normally closed)
B	Solenoid valve	I	Emergency release valve (normally closed)	P	Riser check valve (with drain trim) <sup>1</sup>
C	Butterfly valve	J	Water supply pressure gauge	Q	PS-40 switch
D	In-line check valve	K	Main drain	R	Alarm test valve
E	1/8" Restricted orifice (M x M)	L	Pressure Operated Relief Valve (P.O.R.V.)	S	Air gauge
F	Y-strainer	M	Swing check valve	T	PS-10 switch
G	Priming valve (normally open)	N	1/8" Restricted orifice (M x F) (not shown)	1	Drain connection

NOTE: Piping shown for reference only.

<sup>1</sup> Zurn is a registered trademark of Zurn Industries, LLC/Wilkins



# TECHNICAL DATA

**MODEL VXD DOUBLE INTERLOCKED  
PREACTION SYSTEM WITH  
ELECTRIC/PNEUMATIC RELEASE**

The Viking Corporation, 210 N Industrial Park Drive, Hastings MI 49058  
Telephone: 269-945-9501 Technical Services: 877-384-5464 Fax: 269-818-1680 Email: techsvcs@vikingcorp.com  
Visit the Viking website for the latest edition of this technical data page www.vikinggroupinc.com

## 4.2 VXD Double Interlock PT Components

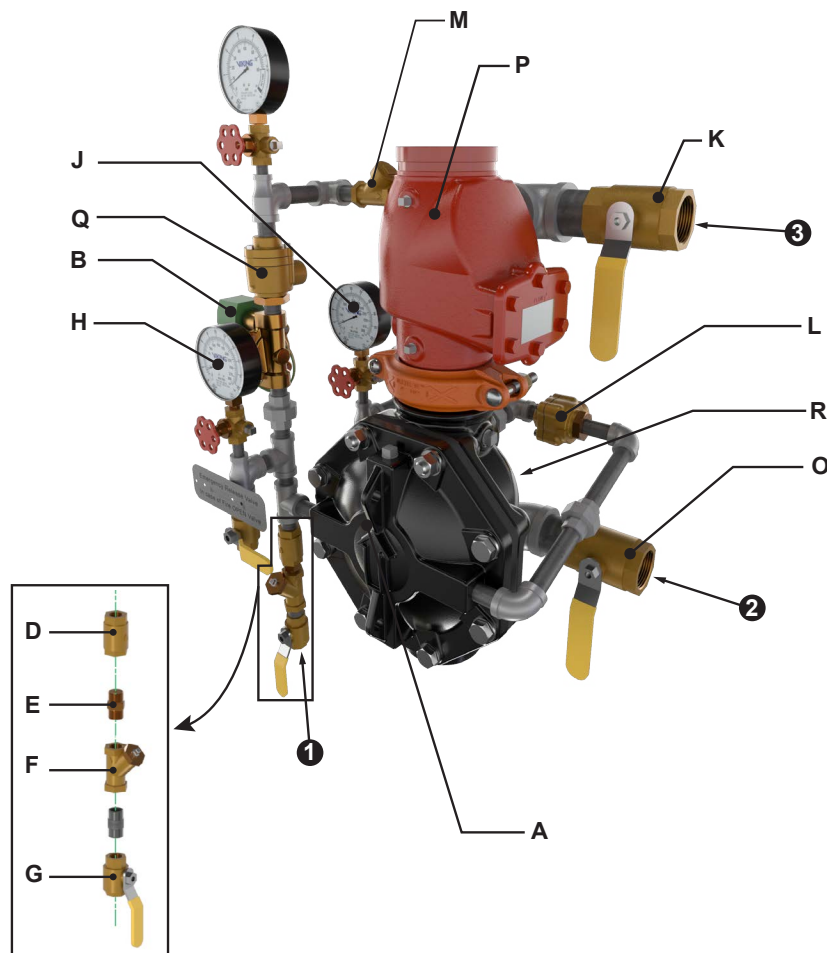

**Figure 4: PT/Loose System Components (4" Shown)**

Item	Description	Item	Description	Item	Description
A	Deluge valve	J	Water supply pressure gauge	1	Prime supply connection point (must be piped to upstream of main water supply valve; piping not provided)
B	Solenoid valve	K	Main drain		
C	Drain cup (not shown)	L	Pressure Operated Relief Valve (P.O.R.V.)	2	Drain connection point (piping not provided)
D	In-line check valve	M	Swing check valve		
E	1/8" Restricted orifice (M x M)	N	1/8" Restricted orifice (M x F) (not shown)	3	Drain connection point (piping not provided)
F	Y-strainer	O	Flow test valve (normally closed)		
G	Priming valve (normally open)	P	Riser check valve (with drain trim)	4	Air supply or Low Air switch (example: PS-40) connection point (devices purchased separately)
H	Prime pressure gauge	Q	Pneumatic actuator		
I	Emergency release valve (normally closed)	R	Alarm test valve (normally closed)		

NOTE: Piping shown for reference only.



## TECHNICAL DATA

MODEL VXD DOUBLE INTERLOCKED  
PREACTION SYSTEM WITH  
ELECTRIC/PNEUMATIC RELEASE

The Viking Corporation, 210 N Industrial Park Drive, Hastings MI 49058  
Telephone: 269-945-9501 Technical Services: 877-384-5464 Fax: 269-818-1680 Email: techsvcs@vikingcorp.com  
Visit the Viking website for the latest edition of this technical data page [www.vikinggroupinc.com](http://www.vikinggroupinc.com)

### 5. SYSTEM OPERATION

#### 5.1 In the SET condition:

System water supply pressure enters the priming chamber of the deluge valve through the priming line which includes a normally open priming valve (A), strainer (B), restricted orifice (not shown), and check valve (C). In the SET condition, water supply pressure is trapped in the priming chamber by check valve (C), pneumatic actuator (H), normally closed solenoid valve (E), and emergency release (F). The water supply pressure trapped in the priming chamber holds the deluge valve diaphragm closed, keeping the outlet chamber and system piping dry.

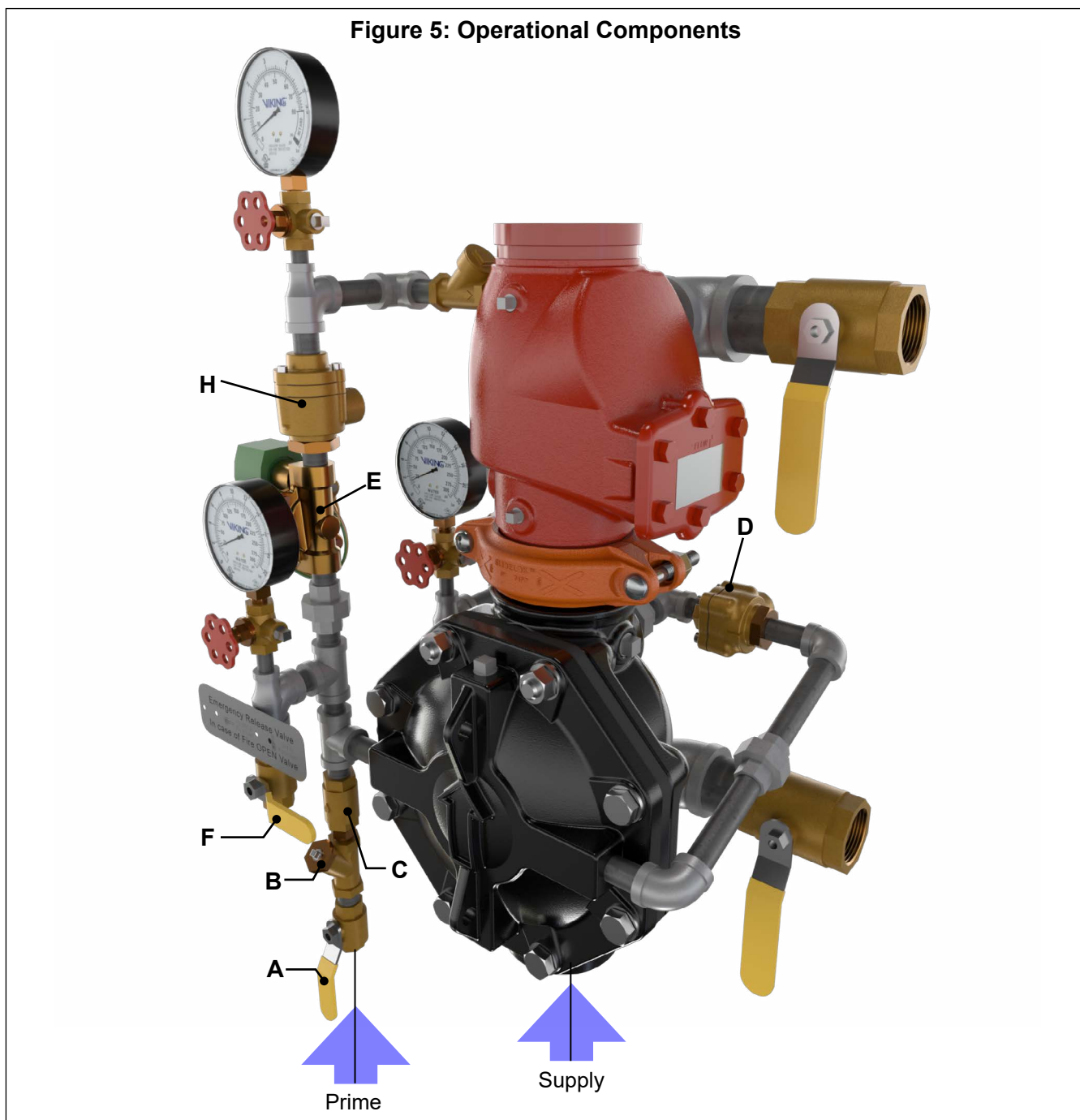



## TECHNICAL DATA

MODEL VXD DOUBLE INTERLOCKED  
PREACTION SYSTEM WITH  
ELECTRIC/PNEUMATIC RELEASE

The Viking Corporation, 210 N Industrial Park Drive, Hastings MI 49058  
Telephone: 269-945-9501 Technical Services: 877-384-5464 Fax: 269-818-1680 Email: techsvcs@vikingcorp.com  
Visit the Viking website for the latest edition of this technical data page [www.vikinggroupinc.com](http://www.vikinggroupinc.com)

### 5.2 In fire conditions:

In a fire condition, when the detection system operates, system release control panel energizes solenoid valve (E) open. Alarms activate, but the deluge valve will NOT open until a sprinkler opens relieving air/nitrogen pressure from the sprinkler system. When a sprinkler opens, supervisory pressure in the sprinkler piping is reduced causing the pneumatic actuator (H) to open. After BOTH the electric detection system activates AND air/nitrogen in the sprinkler system has been lost, pressure is released from the priming chamber faster than it is supplied through restricted orifice. The deluge valve diaphragm opens to allow water to flow into the system piping and alarm devices, causing water motor alarm and water flow alarms connected to alarm pressure switch to activate.

When the deluge valve operates, water is drained from the PORV (D) inlet. When the 10:1 differential is overcome, the push rod opens, allowing the prime water to drain. If a release resets, priming water will continue to escape through the PORV, allowing the deluge valve to continue to operate until the system is reset. The Deluge Valve can only be reset after the system is taken out of service, and the outlet chamber of the deluge valve and associated trim piping are de-pressurized and drained.

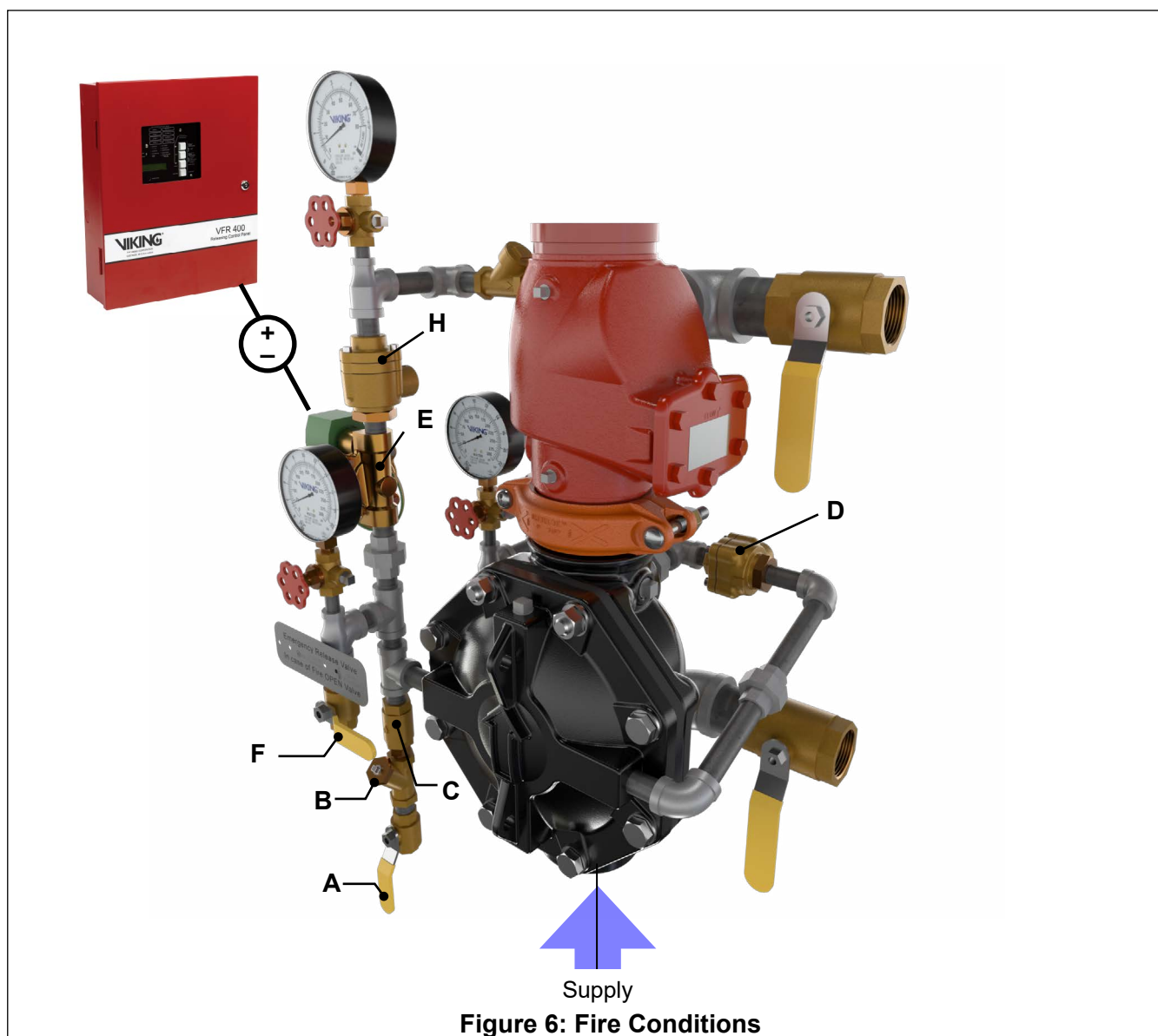



## TECHNICAL DATA

### MODEL VXD DOUBLE INTERLOCKED PREACTION SYSTEM WITH ELECTRIC/PNEUMATIC RELEASE

The Viking Corporation, 210 N Industrial Park Drive, Hastings MI 49058  
 Telephone: 269-945-9501 Technical Services: 877-384-5464 Fax: 269-818-1680 Email: techsvcs@vikingcorp.com  
 Visit the Viking website for the latest edition of this technical data page [www.vikinggroupinc.com](http://www.vikinggroupinc.com)

#### 5.3 In trouble conditions:

If a sprinkler opens prior to operation of the detection system, or any time supervisory pressure in the sprinkler piping is lost, the air supervisory switch will signal a low air pressure condition, but the deluge valve will NOT open. If the electric detection system operates due to mechanical damage or malfunction, the deluge valve will NOT open.

#### 5.4 Manual operation:

Anytime the emergency release is pulled, pressure is released from the priming chamber and the deluge valve will open. Water will flow into the system piping and alarm devices. Water will flow from any open sprinklers and/or spray nozzles on the system.

## 6. INSTALLATION

Refer to current Viking Technical Data describing individual components of the Viking VXD Preaction System. Also, refer to applicable installation standards, codes, and Authorities Having Jurisdiction.

### 6.1 Recommended Air Pressure Settings

**NOTE: Installation Standards may allow air/nitrogen pressures lower than those recommended below. When using air/nitrogen pressures lower than the recommended setting noted below, verify that the air regulation equipment and air supervisory switches used are compatible with the air/nitrogen pressure setting used.**

TABLE 2: Recommended Air Pressure Settings		
Device	System Water Pressure	
	Up to 175 PSI (12 bar)	Over 175 PSI (12 bar) to 250 PSI (17 bar)
Set to Maintain:		
Air Compressor On/Off Switch	ON: 30 PSI (2 bar) OFF: 40 PSI (2.8 bar)	ON: 50 PSI (3.4 bar) OFF: 60 PSI (4.1 bar)
Air Maintenance Device (release system)	30 PSI (2 bar)	50 PSI (3.4 bar)
Air Pressure Supervisory Switch (release system)	25 PSI (1.7 bar)	45 PSI (3.1 bar)
Alarm pressure switch	4 to 8 PSI (0.3 to 0.6 bar)	4 to 8 PSI (0.3 to 0.6 bar)

### 6.2 Air Supply Design

The air supply compressor should be sized to establish total required air pressure in 30 minutes. The air supply must be regulated, restricted, and maintained automatically. The air maintenance device is used to regulate and restrict the flow of air/nitrogen into the sprinkler system piping.

The air supply must be regulated to maintain the pressure desired in the release system. Pressure settings other than those recommended in section 6.1 above may affect operation of the system. The air/nitrogen supply must be restricted to ensure that the automatic air supply cannot replace air as fast as it escapes when a releasing device operates.

It is recommended practice to provide an inspectors test connection on the pneumatic release system. The inspectors test connection should be equipped with a ball valve (normally locked closed) capable of being opened to simulate the opening of a releasing device. Locate the connection and valve at the highest, most demanding location of the release system. Test connections provided on pneumatic release systems should terminate in an orifice equal to the smallest orifice of the releasing devices provided. The inspectors test connection may be used to verify that the automatic air supply cannot replace air as fast as it escapes when a releasing device operates. Refer to section 9. Inspections, Tests, and Maintenance.

#### Speed of Operation:

An optional accelerator may be installed to allow the system to fill with water faster. An accelerator may be necessary to meet water delivery time requirements.



## TECHNICAL DATA

MODEL VXD DOUBLE INTERLOCKED  
PREACTION SYSTEM WITH  
ELECTRIC/PNEUMATIC RELEASE

The Viking Corporation, 210 N Industrial Park Drive, Hastings MI 49058  
Telephone: 269-945-9501 Technical Services: 877-384-5464 Fax: 269-818-1680 Email: techsvcs@vikingcorp.com  
Visit the Viking website for the latest edition of this technical data page [www.vikinggroupinc.com](http://www.vikinggroupinc.com)

### 7. PLACING THE SYSTEM IN SERVICE

Placing the Valve in Service:

1. Verify the following:
  - The system main water supply control valve (not shown) is closed.
  - The system has been properly drained and main drain (J) is open.
  - The emergency release (F) is closed.
2. Close the system main drain (J).
3. Restore air/nitrogen to the sprinkler piping. Verify that the 1/2" valve in the air maintenance device by-pass trim is closed and that both the 1/4" valves are open.
4. Establish a normal condition on the release control panel.
5. Open the priming valve (A).
6. Open flow test valve (G).
7. Slowly and partially open main water supply control valve (not shown).
 

**NOTE: Opening the main water supply valve too quickly can create excessive pressure causing the valve to trip.**
8. When full flow develops from the flow test valve (G), close the valve. Verify that there is no flow from the open orifice.
9. Fully open and secure the main water supply control valve.
10. Verify that all valves are in their normal operating position.
11. Verify that no water is discharging into the drain cup.
12. Check for, and repair all leaks.
13. On new installations, those systems that have been placed out of service, or where new equipment has been installed, trip test the system to verify that all equipment functions properly. Refer to Annual Trip Tests, section 9.2.C.
14. After completing a trip test, perform semi-annual maintenance. Refer to section 9.3.B.

#### CAUTION

Performing a trip test results in operation of the Deluge Valve. Water will flow into the sprinkler piping. Take necessary precautions to prevent damage.

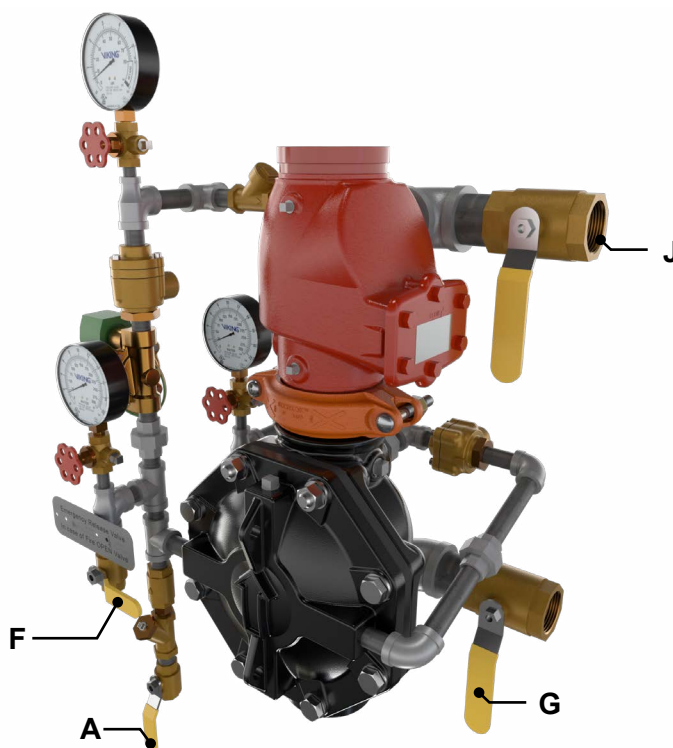

Figure 7: Placing the System in Service



## TECHNICAL DATA

MODEL VXD DOUBLE INTERLOCKED  
PREACTION SYSTEM WITH  
ELECTRIC/PNEUMATIC RELEASE

The Viking Corporation, 210 N Industrial Park Drive, Hastings MI 49058  
Telephone: 269-945-9501 Technical Services: 877-384-5464 Fax: 269-818-1680 Email: techsvcs@vikingcorp.com  
Visit the Viking website for the latest edition of this technical data page [www.vikinggroupinc.com](http://www.vikinggroupinc.com)

### 8. EMERGENCY INSTRUCTIONS

#### ⚠ WARNING

**WARNING:** Placing a control valve or detection system out of service may eliminate the fire protection capabilities of the system. Prior to proceeding, notify all Authorities Having Jurisdiction (AHJ). Consideration should be given to employment of a fire patrol in the affected areas.

Refer to the appropriate technical data page and NFPA standards for complete care, handling, installation, and maintenance instructions. For additional product and system information, Viking data pages and installation instructions are available on the Viking Web site at [www.vikinggroupinc.com](http://www.vikinggroupinc.com).

#### To take system out of service (Refer to Figure 7):

After a fire, verify that the fire is OUT and that placing the system out of service has been authorized by the appropriate Authority Having Jurisdiction.

1. Close the water supply control valve (not shown).  
**NOTE: Sprinkler systems that have been subjected to a fire must be returned to service as soon as possible. The entire system must be inspected for damage, and repaired or replaced as necessary.**
2. Open the system main drain.
3. Shut off the air supply (optional).
4. Close the priming valve (A).
5. Replace any release devices, sprinklers and/or spray nozzles that have been damaged or have been exposed to fire conditions.
6. Perform all maintenance procedures recommended in Technical Data describing individual components of the system that have operated.
7. Return the system to service as soon as possible. Refer to section 7: Placing the System In Service.

### 9. INSPECTIONS, TESTS, AND MAINTENANCE

#### ⚠ WARNING

Any system maintenance that involves placing a control valve or detection system out of service may eliminate the fire protection capabilities of that system. Prior to proceeding, notify all Authorities Having Jurisdiction. Consideration should be given to employment of a fire patrol in the affected areas.

#### ⚠ WARNING

**Risk of death or serious injury.** Having the system out of service may lead to a situation that could cause death or serious injury. If the coil to the monitored solenoid valve is removed, the release control panel will provide a supervisory alarm and the system will be out of service. The solenoid valve must have the coil connected for the system to remain in service.

- Contact the manufacturer, ASCO, or refer to the manufacturer's documentation for more information.

#### NOTICE

**The owner is responsible for maintaining the fire protection system and devices in proper operating condition.**

It is imperative that the system be inspected and tested on a regular basis in accordance with NFPA 25. Refer to current Viking Technical Data describing individual components.

The frequency of the inspections may vary due to contaminated water supplies, corrosive water supplies, corrosive atmospheres, as well as the condition of the air supply to the system. For minimum maintenance and inspection requirements, refer to NFPA 25. In addition, the Authority Having Jurisdiction may have additional maintenance, testing, and inspection requirements that must be followed.



## TECHNICAL DATA

MODEL VXD DOUBLE INTERLOCKED  
PREACTION SYSTEM WITH  
ELECTRIC/PNEUMATIC RELEASE

The Viking Corporation, 210 N Industrial Park Drive, Hastings MI 49058  
Telephone: 269-945-9501 Technical Services: 877-384-5464 Fax: 269-818-1680 Email: techsvcs@vikingcorp.com  
Visit the Viking website for the latest edition of this technical data page [www.vikinggroupinc.com](http://www.vikinggroupinc.com)

### 9.1 Inspection

**Weekly - Viking recommends a weekly visual inspection; check the following items.**

- Verify that the main water supply control valve is open and that all other valves are in their normal operating position and appropriately secured. (refer to Figure 7)
- Check for signs of mechanical damage, leakage, and/or corrosive activity. If detected, perform maintenance as required. If necessary, replace the device.
- Verify that the valve and trim are adequately heated and protected from freezing and physical damage.

**NOTE: For normal operating position, refer to Figure 4.**

### 9.2 Periodic System Tests

#### A. Quarterly Water Flow Alarm Test

1. Notify the Authority Having Jurisdiction and those in the area affected by the test.
2. To test the local electric alarm (if provided) and/or mechanical water motor alarm (if provided), OPEN the alarm test valve in the Deluge Valve trim.
  - a. Electric alarm pressure switches (if provided) should activate.
  - b. Electric local alarms should be audible.
  - c. The local water motor gong should be audible.
  - d. If equipped with remote station alarm signaling devices, verify that alarm signals were received.
3. When testing is complete, CLOSE the Alarm Test Valve.
4. Verify the following:
  - a. All local alarms stop sounding and alarm panels (if provided) reset.
  - b. All remote station alarms reset.
  - c. Supply piping to water motor alarm properly drains.
5. Verify that the Alarm Test Valve is CLOSED.
6. Verify that the outlet chamber is free of water. No water should flow from the alarm drain line.
7. Notify the Authority Having Jurisdiction and those in the affected area that testing is complete.

#### B. Quarterly Main Drain Test

1. Notify the Authority Having Jurisdiction and those in the area affected by the test.
2. Record pressure reading from the water supply pressure gauge.
3. Verify that the outlet chamber of the Deluge Valve is free of water. No water should flow from the alarm drain line.
4. Fully OPEN the Flow Test Valve.
5. When a full flow is developed from the Flow Test Valve, record the residual pressure from the water supply pressure gauge.
6. When the test is complete, SLOWLY CLOSE the Flow Test Valve.
7. Compare test results with previous flow information. If deterioration of the water supply is detected, take appropriate steps to restore adequate water supply.
8. Verify:
  - a. Normal water supply pressure has been restored to the inlet chamber, the priming chamber, and the release system. The pressure on the priming chamber water pressure gauge should equal the system water supply pressure.
  - b. All alarm devices and valves are secured in normal operating position (refer to Figure 4).
9. Notify the Authority Having Jurisdiction that the test is complete. Record and/or provide notification of test results as required by the Authority Having Jurisdiction.

#### C. Annual Trip Test

#### **CAUTION**

**Performing this test results in operation of the Deluge Valve. Water will flow into the sprinkler piping and from any open sprinklers and/or nozzles. Take necessary precautions to prevent damage.**

1. Notify the Authority Having Jurisdiction and those in the area affected by the test.
2. Fully open the Flow Test Valve to flush away any accumulation of foreign material.
3. Close the Flow Test Valve.
4. To trip the deluge valve:
  - a. Operate a detector according to the manufacturer's instructions.



## TECHNICAL DATA

MODEL VXD DOUBLE INTERLOCKED  
PREACTION SYSTEM WITH  
ELECTRIC/PNEUMATIC RELEASE

The Viking Corporation, 210 N Industrial Park Drive, Hastings MI 49058  
Telephone: 269-945-9501 Technical Services: 877-384-5464 Fax: 269-818-1680 Email: techsvcs@vikingcorp.com  
Visit the Viking website for the latest edition of this technical data page [www.vikinggroupinc.com](http://www.vikinggroupinc.com)

- b. Open the sprinkler system inspector's test valve.
5. When test is complete:
  - a. Close the Main Water Supply Control Valve.
  - b. Close the Priming Valve.
  - c. Open all system main drains. Allow the system to drain completely.
6. Perform semi-annual maintenance. Refer to section 9.3.B: Semi-Annual Maintenance.
7. Place the system in service. Refer to section: "7. Placing the System in Service".
8. Notify the Authority Having Jurisdiction that the test is complete. Record and/or provide notification of test results as required by the Authority Having Jurisdiction.

### D. Quarterly "Low Air" Pressure Alarm Test

#### IMPORTANT

**Do not operate the electric detection system during this test.**

1. Notify the Authority Having Jurisdiction and those in the area affected by the test.
2. Close the main water supply valve.  
**NOTE: Closing the main water supply valve prevents operation of the deluge valve during the test.**
3. Fully OPEN the test connection to simulate operation of a sprinkler.
4. Verify that the low air alarms operate within an acceptable time period and continue without interruption.
5. Close the test connection.
6. Establish recommended air/nitrogen pressure to be maintained. Refer to section "6.1 Recommended Air Pressure Settings".
7. Reset the system release control panel to stop the alarms.
8. Return the system to service. Refer to section: "7. Placing the System in Service".

## 9.3 Maintenance

### A. After Each Operation:

1. Sprinkler systems that have been subjected to a fire must be returned to service as soon as possible. The entire system must be inspected for damage, and repaired or replaced as necessary.
2. Deluge Valves and trim that have been subjected to brackish water, salt water, foam/water solution, or any other corrosive water supply, should be flushed with good quality fresh water before being returned to service.
3. Perform semi-annual maintenance after every operation.

### B. Semi-Annually:

1. Remove the system from service.
2. Close the Main Water Supply Control Valve and Priming Valve.
3. Relieve pressure in the priming chamber by opening the emergency release Valve.
4. Inspect all trim for signs of corrosion and/or blockage. Clean and/or replace as required.
5. Clean and/or replace all strainer screens.
6. Refer to section: "7. Placing the System in Service".

### C. Every Fifth Year:

1. Internal inspection of Deluge Valves is recommended every five years unless inspections and tests indicate more frequent internal inspections are required. Refer to the Model VXD Valve Technical Data Page.
2. Internal inspection of strainers, and restricted orifices is recommended every five years unless inspections and tests indicate more frequent internal inspections are required.
3. Record and provide notification of inspection results as required by the Authority Having Jurisdiction.



# TECHNICAL DATA

**MODEL VXD DOUBLE INTERLOCKED  
PREACTION SYSTEM WITH  
ELECTRIC/PNEUMATIC RELEASE**

The Viking Corporation, 210 N Industrial Park Drive, Hastings MI 49058  
 Telephone: 269-945-9501 Technical Services: 877-384-5464 Fax: 269-818-1680 Email: techsvcs@vikingcorp.com  
 Visit the Viking website for the latest edition of this technical data page [www.vikinggroupinc.com](http://www.vikinggroupinc.com)

## 10. DIMENSIONS

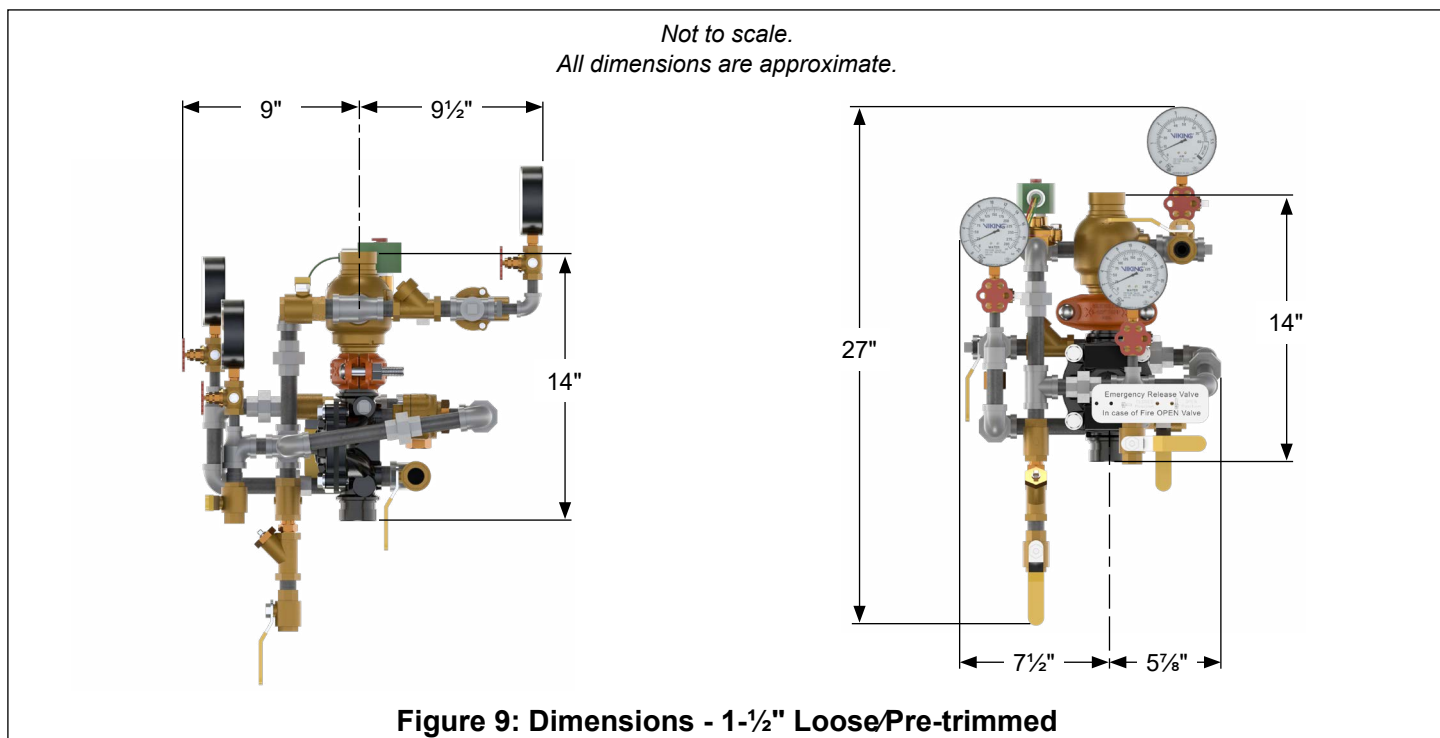
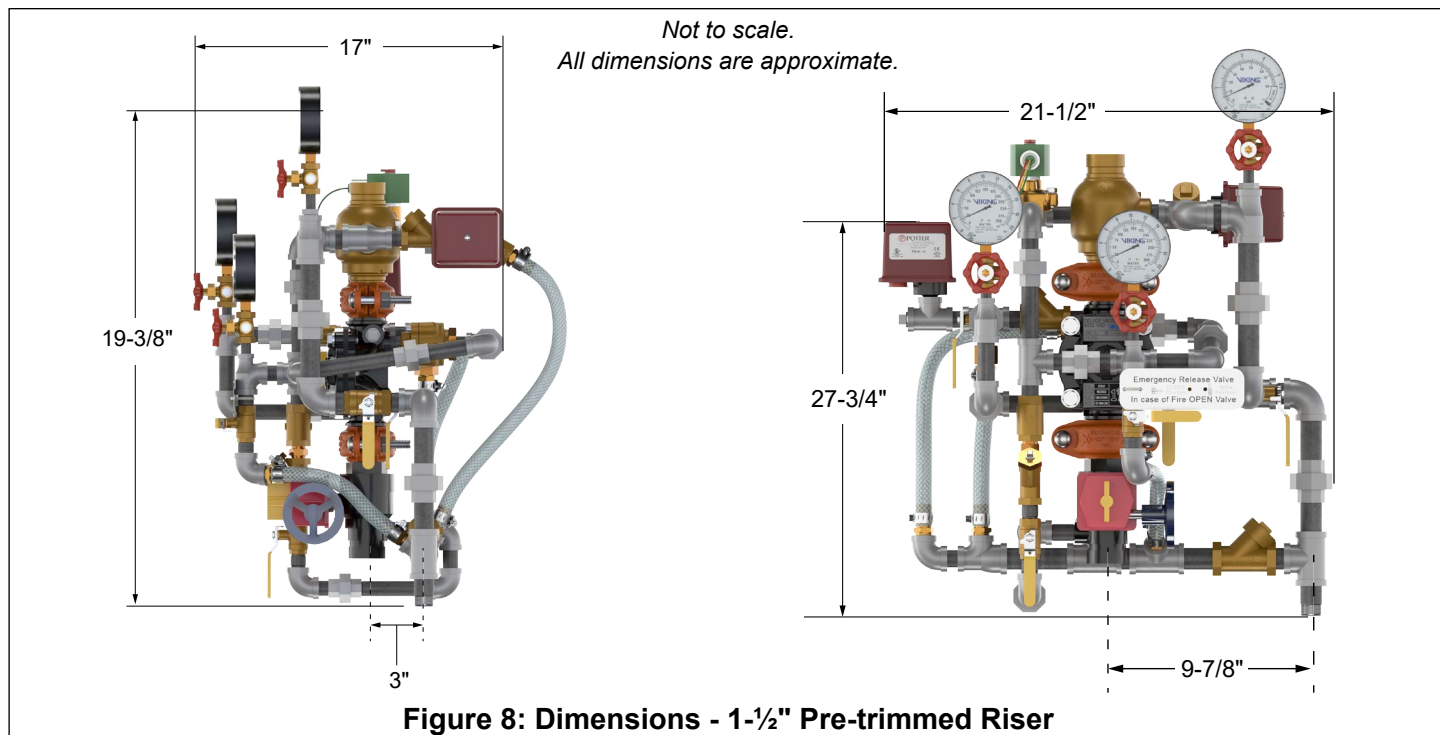



# TECHNICAL DATA

**MODEL VXD DOUBLE INTERLOCKED  
PREACTION SYSTEM WITH  
ELECTRIC/PNEUMATIC RELEASE**

The Viking Corporation, 210 N Industrial Park Drive, Hastings MI 49058  
 Telephone: 269-945-9501 Technical Services: 877-384-5464 Fax: 269-818-1680 Email: techsvcs@vikingcorp.com  
 Visit the Viking website for the latest edition of this technical data page [www.vikinggroupinc.com](http://www.vikinggroupinc.com)

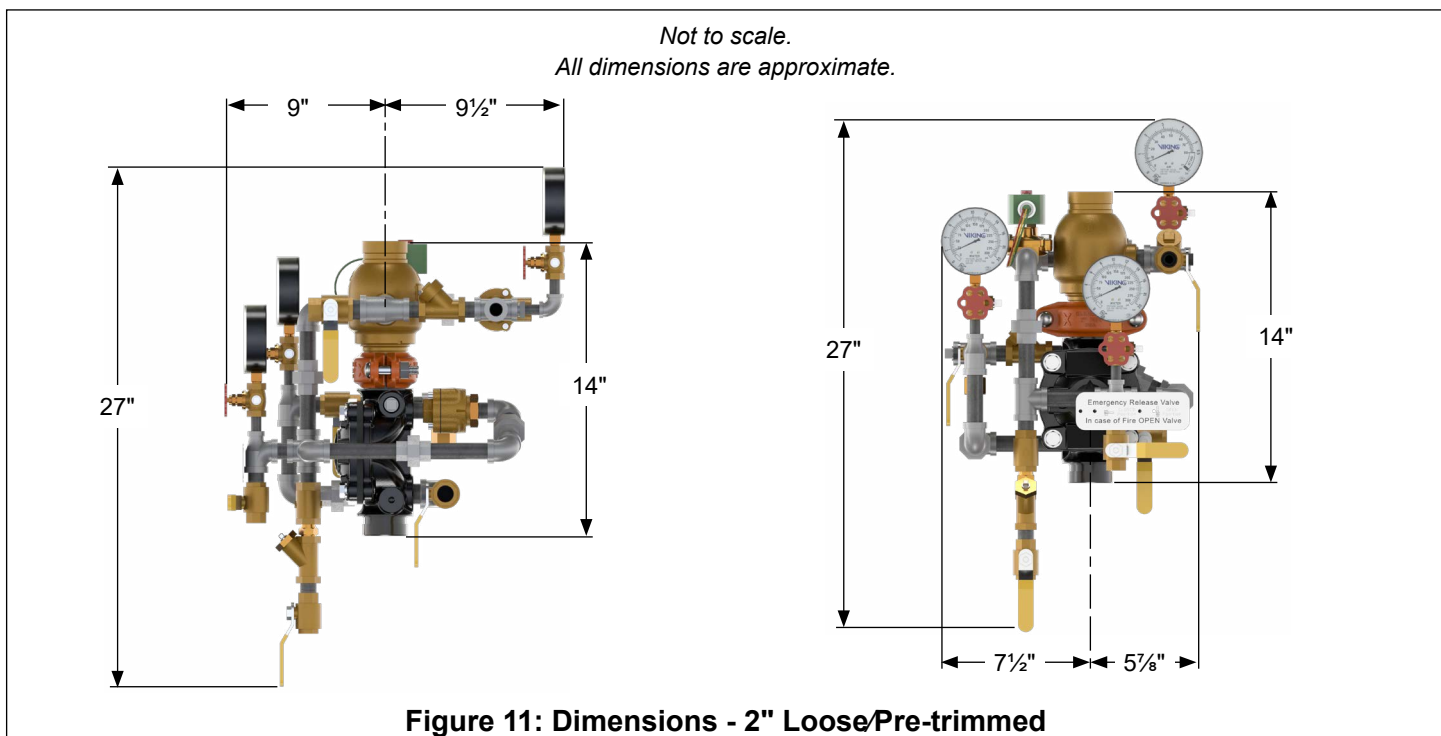
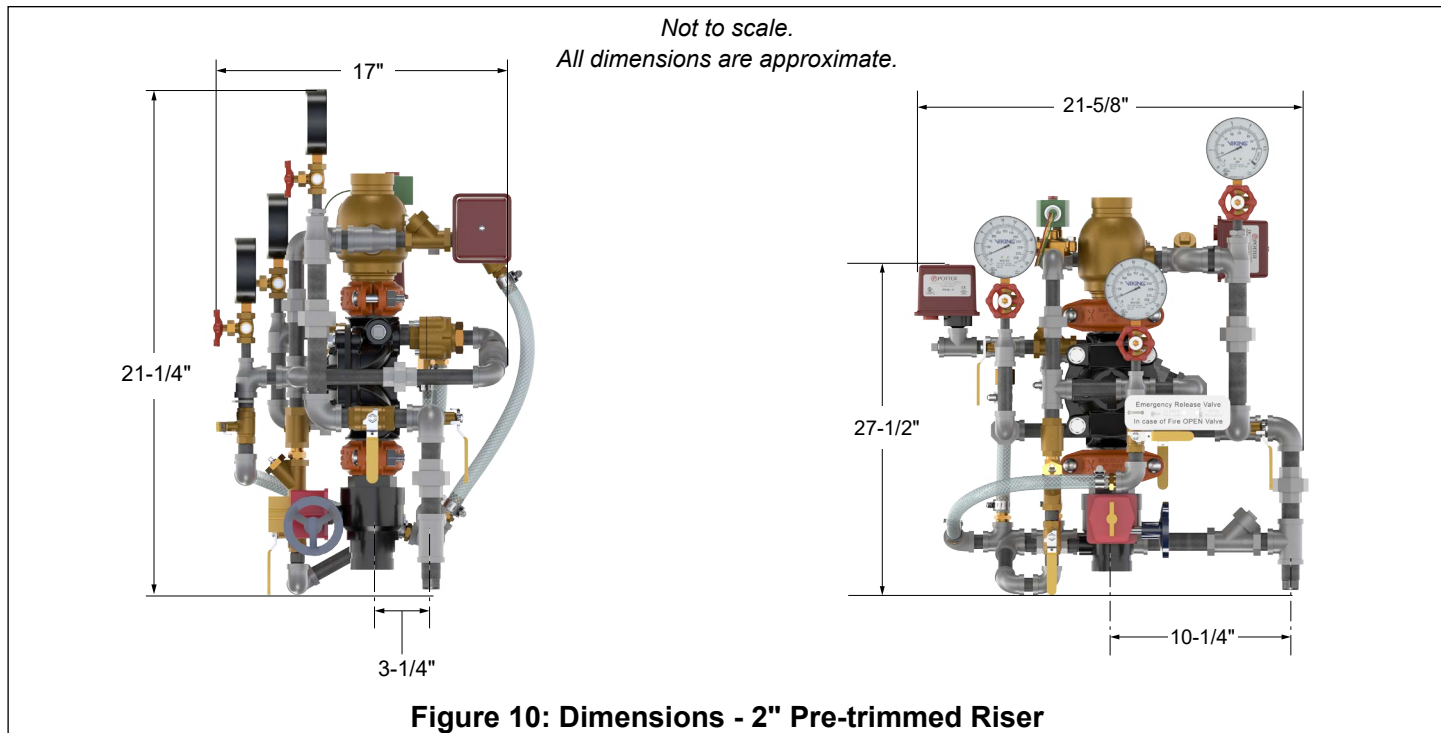



# TECHNICAL DATA

**MODEL VXD DOUBLE INTERLOCKED  
PREACTION SYSTEM WITH  
ELECTRIC/PNEUMATIC RELEASE**

The Viking Corporation, 210 N Industrial Park Drive, Hastings MI 49058  
 Telephone: 269-945-9501 Technical Services: 877-384-5464 Fax: 269-818-1680 Email: techsvcs@vikingcorp.com  
 Visit the Viking website for the latest edition of this technical data page [www.vikinggroupinc.com](http://www.vikinggroupinc.com)

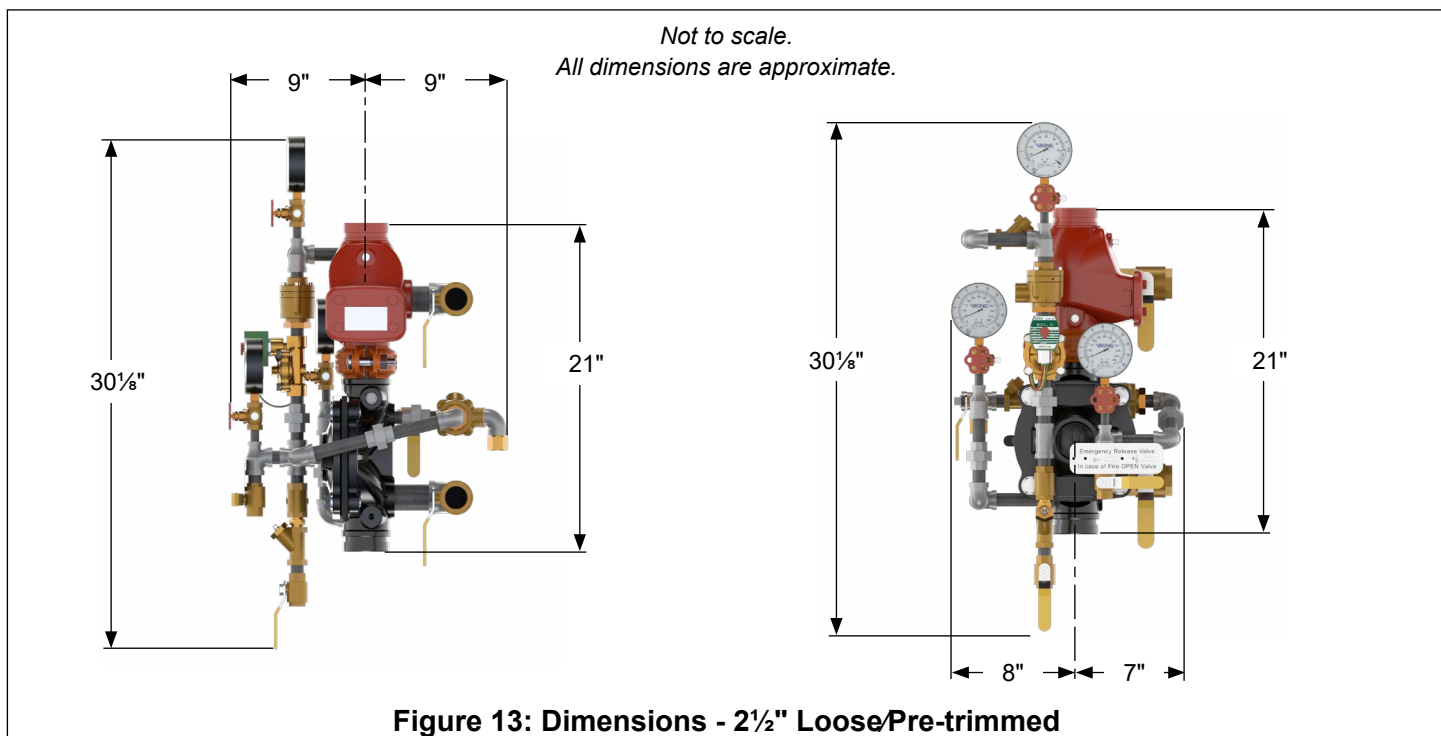
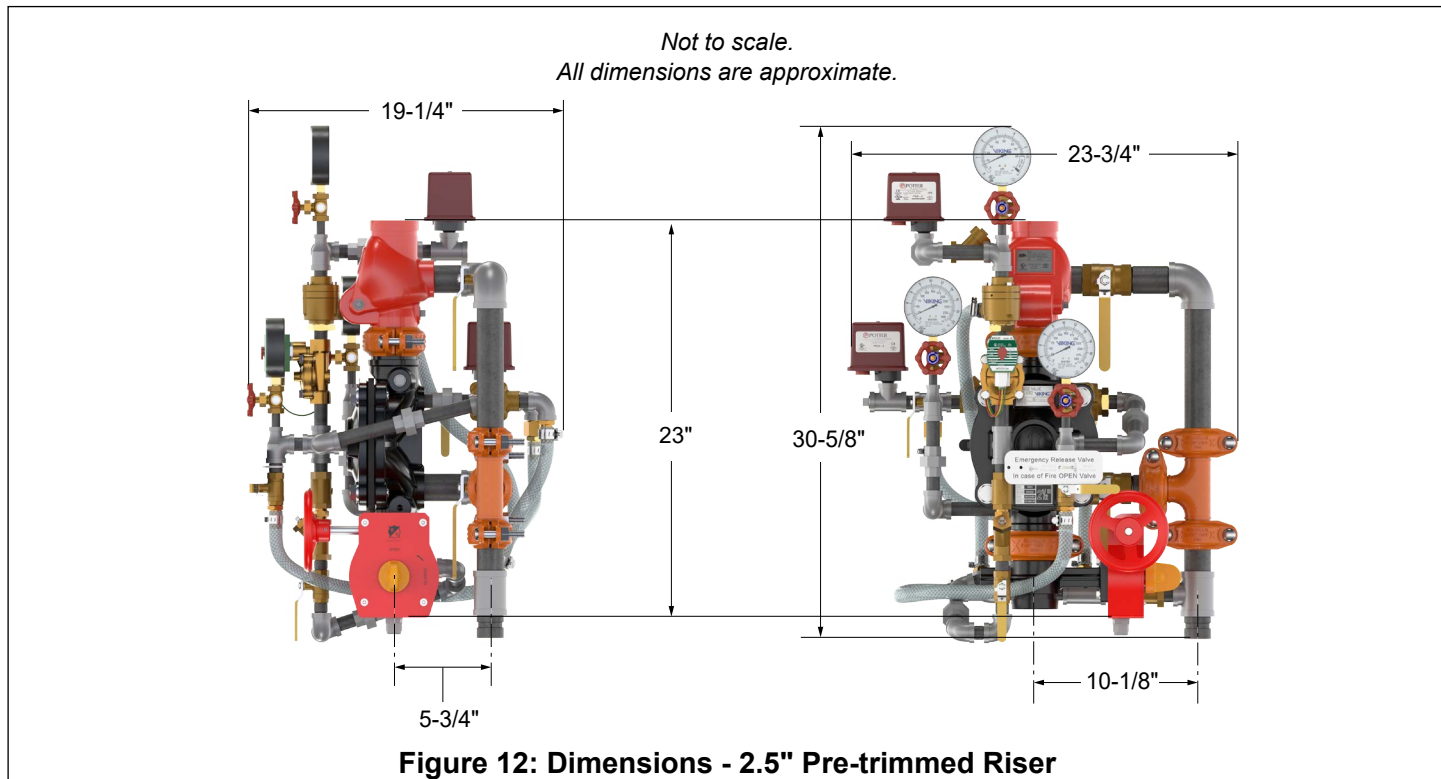



# TECHNICAL DATA

**MODEL VXD DOUBLE INTERLOCKED  
PREACTION SYSTEM WITH  
ELECTRIC/PNEUMATIC RELEASE**

The Viking Corporation, 210 N Industrial Park Drive, Hastings MI 49058  
 Telephone: 269-945-9501 Technical Services: 877-384-5464 Fax: 269-818-1680 Email: techsvcs@vikingcorp.com  
 Visit the Viking website for the latest edition of this technical data page [www.vikinggroupinc.com](http://www.vikinggroupinc.com)

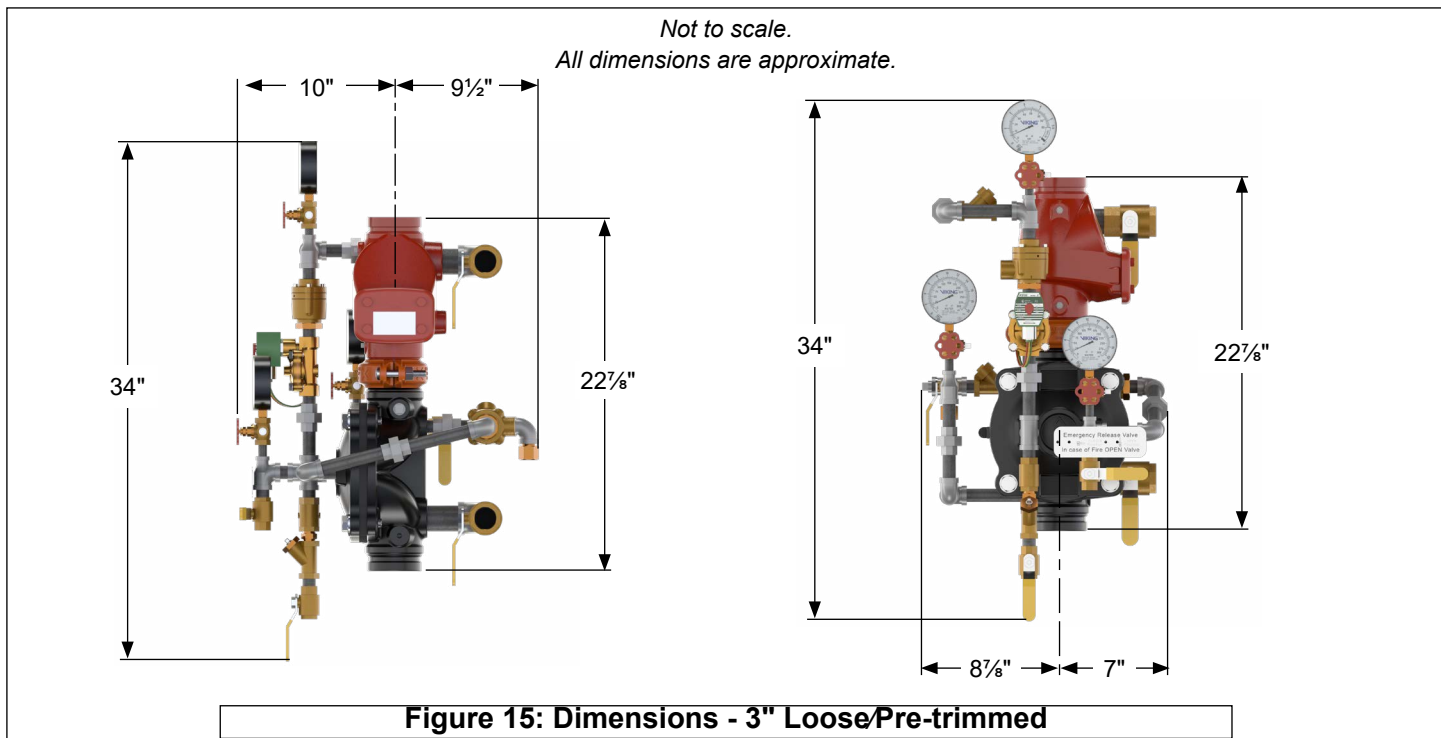
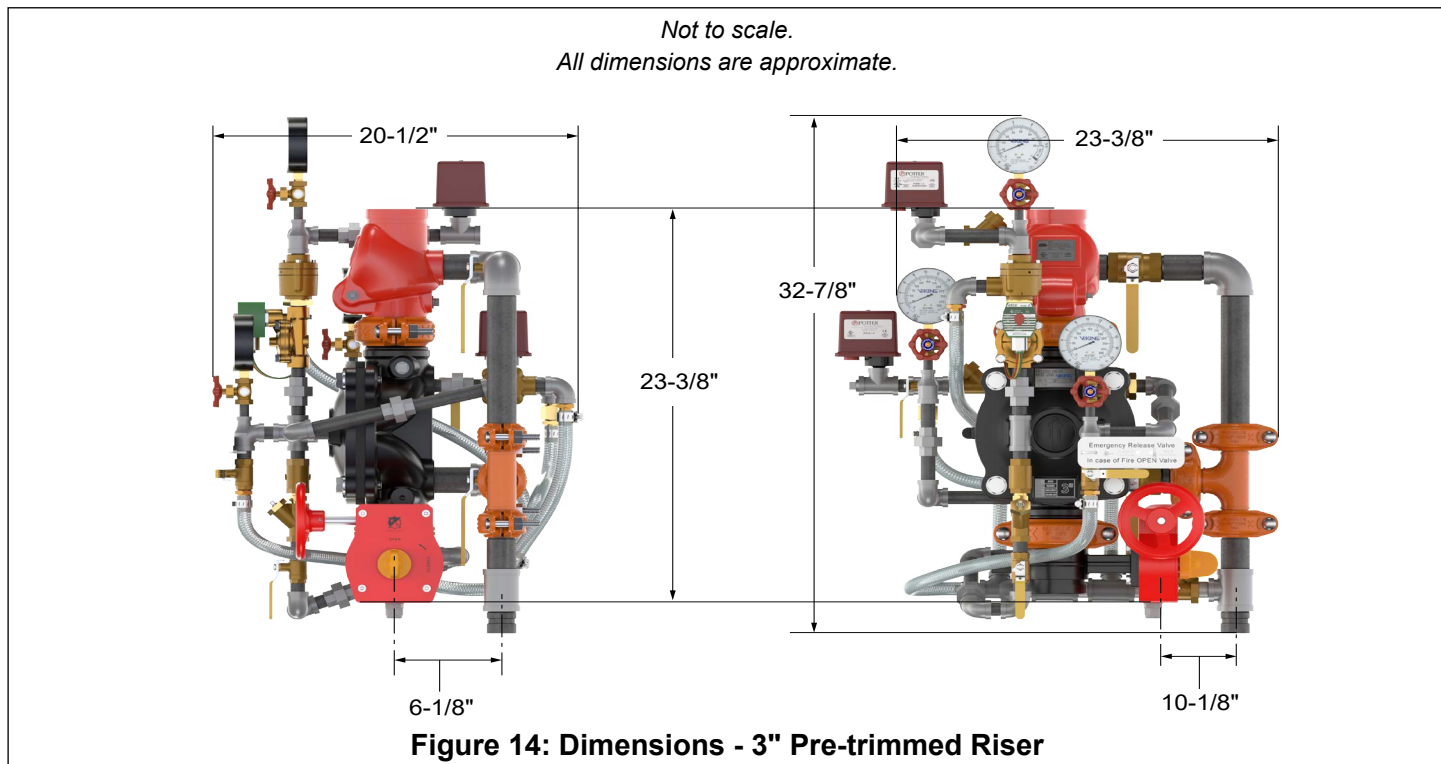



# TECHNICAL DATA

**MODEL VXD DOUBLE INTERLOCKED  
PREACTION SYSTEM WITH  
ELECTRIC/PNEUMATIC RELEASE**

The Viking Corporation, 210 N Industrial Park Drive, Hastings MI 49058  
 Telephone: 269-945-9501 Technical Services: 877-384-5464 Fax: 269-818-1680 Email: techsvcs@vikingcorp.com  
 Visit the Viking website for the latest edition of this technical data page [www.vikinggroupinc.com](http://www.vikinggroupinc.com)

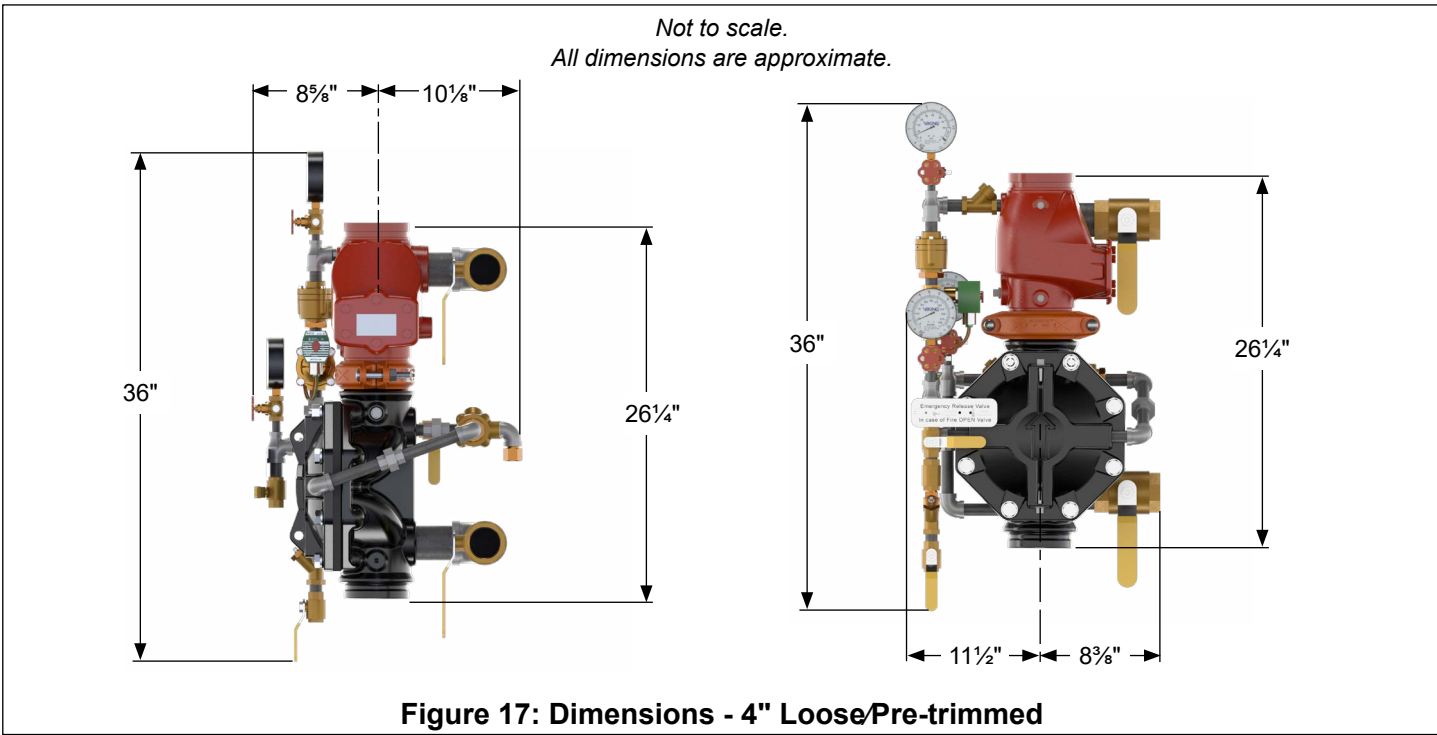
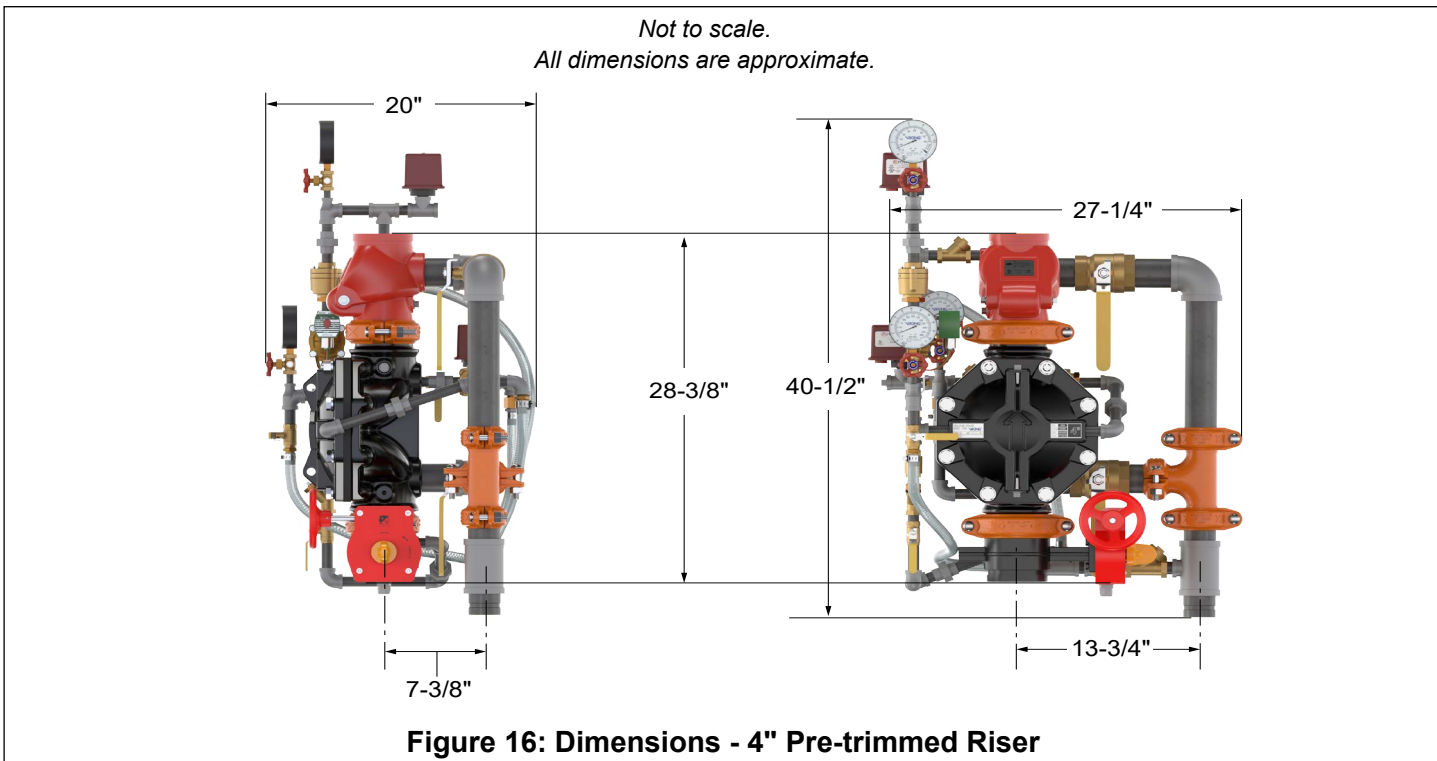



# TECHNICAL DATA

**MODEL VXD DOUBLE INTERLOCKED  
PREACTION SYSTEM WITH  
ELECTRIC/PNEUMATIC RELEASE**

The Viking Corporation, 210 N Industrial Park Drive, Hastings MI 49058  
 Telephone: 269-945-9501 Technical Services: 877-384-5464 Fax: 269-818-1680 Email: techsvcs@vikingcorp.com  
 Visit the Viking website for the latest edition of this technical data page [www.vikinggroupinc.com](http://www.vikinggroupinc.com)

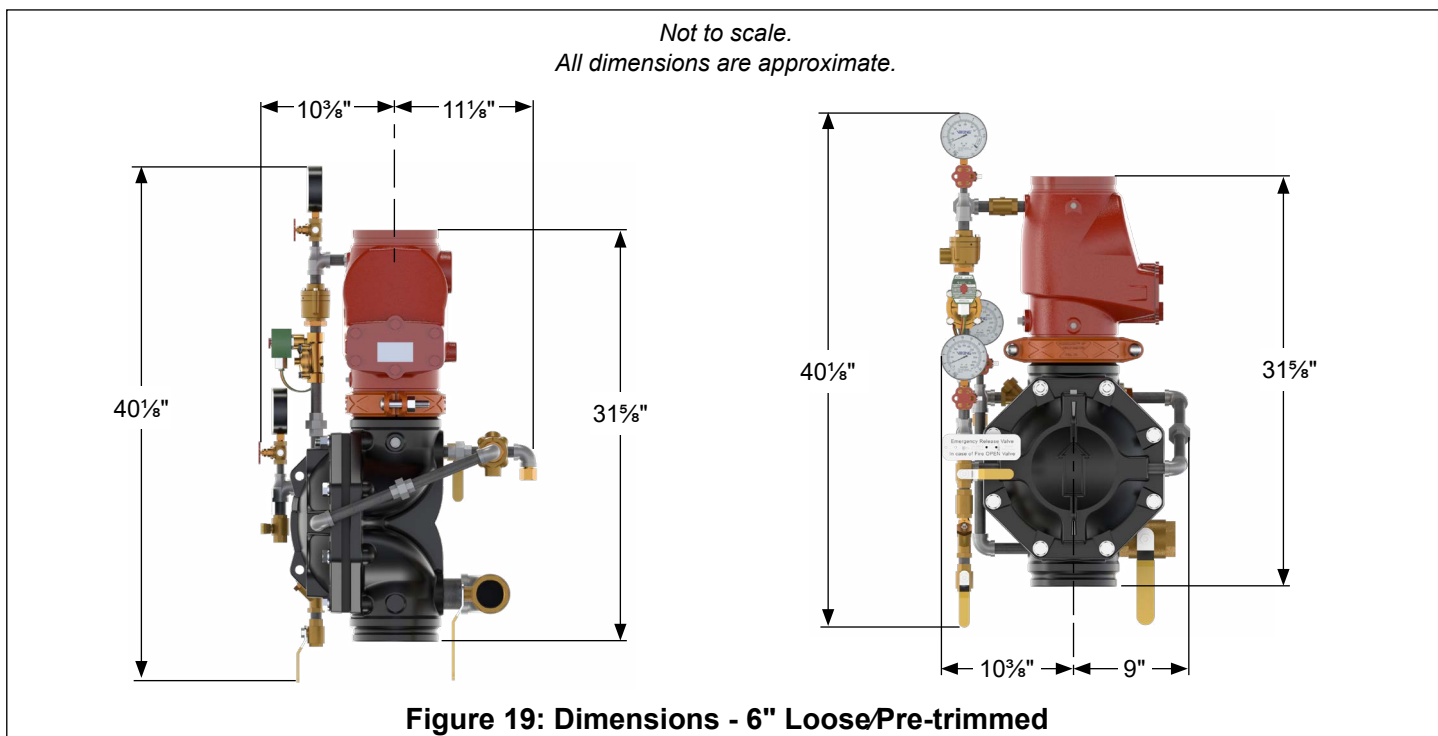
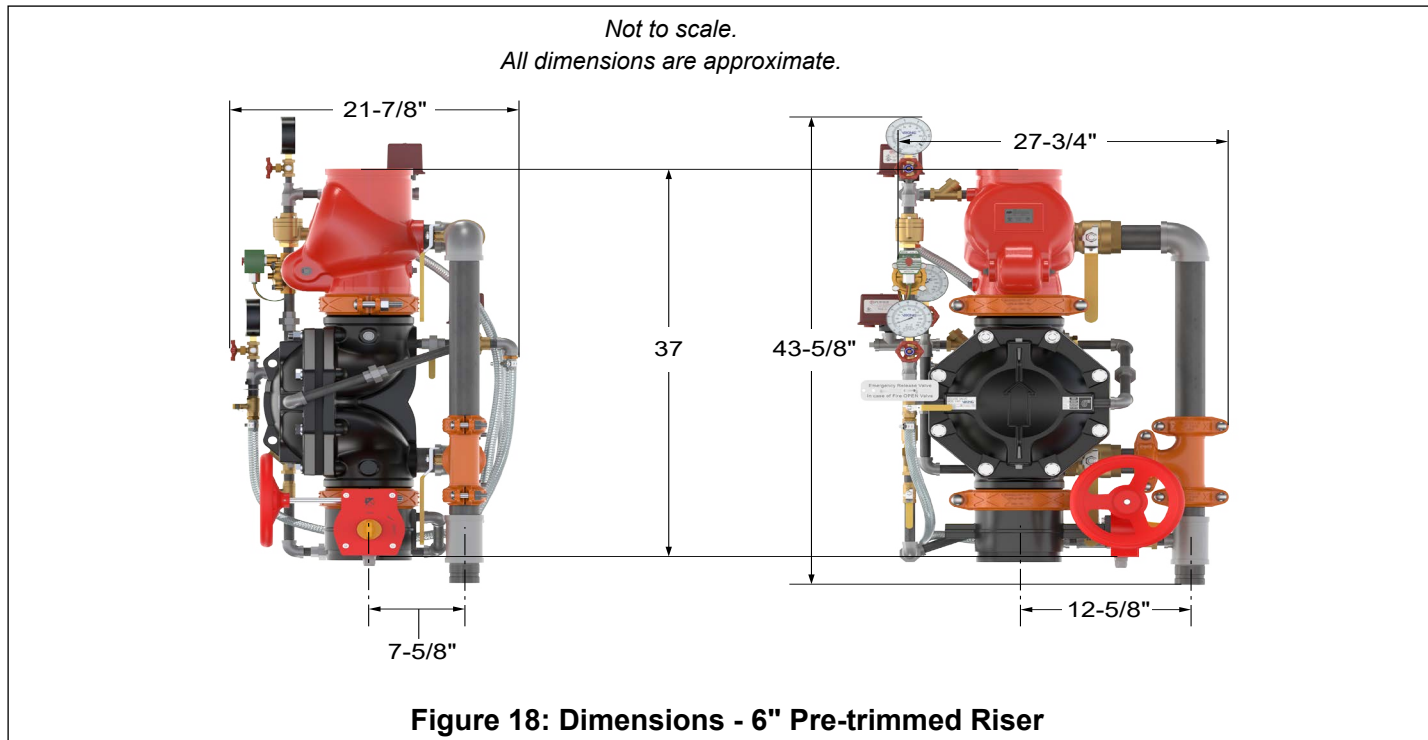



# TECHNICAL DATA

**MODEL VXD DOUBLE INTERLOCKED  
PREACTION SYSTEM WITH  
ELECTRIC/PNEUMATIC RELEASE**

The Viking Corporation, 210 N Industrial Park Drive, Hastings MI 49058  
 Telephone: 269-945-9501 Technical Services: 877-384-5464 Fax: 269-818-1680 Email: techsvcs@vikingcorp.com  
 Visit the Viking website for the latest edition of this technical data page [www.vikinggroupinc.com](http://www.vikinggroupinc.com)

*Not to scale.  
All dimensions are approximate.*

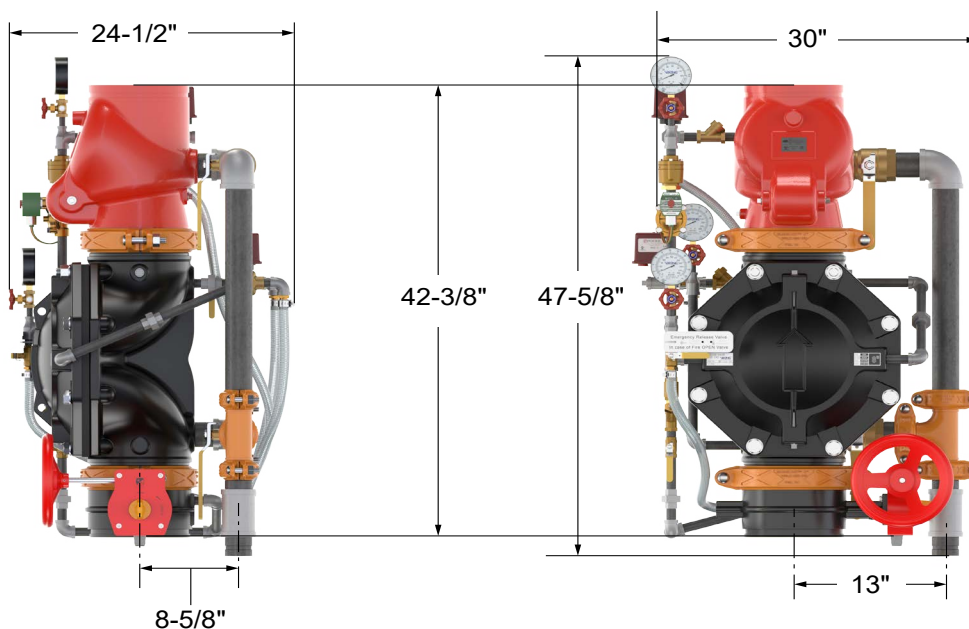

**Figure 20: Dimensions - 8" Pre-trimmed Riser**

*Not to scale.  
All dimensions are approximate.*

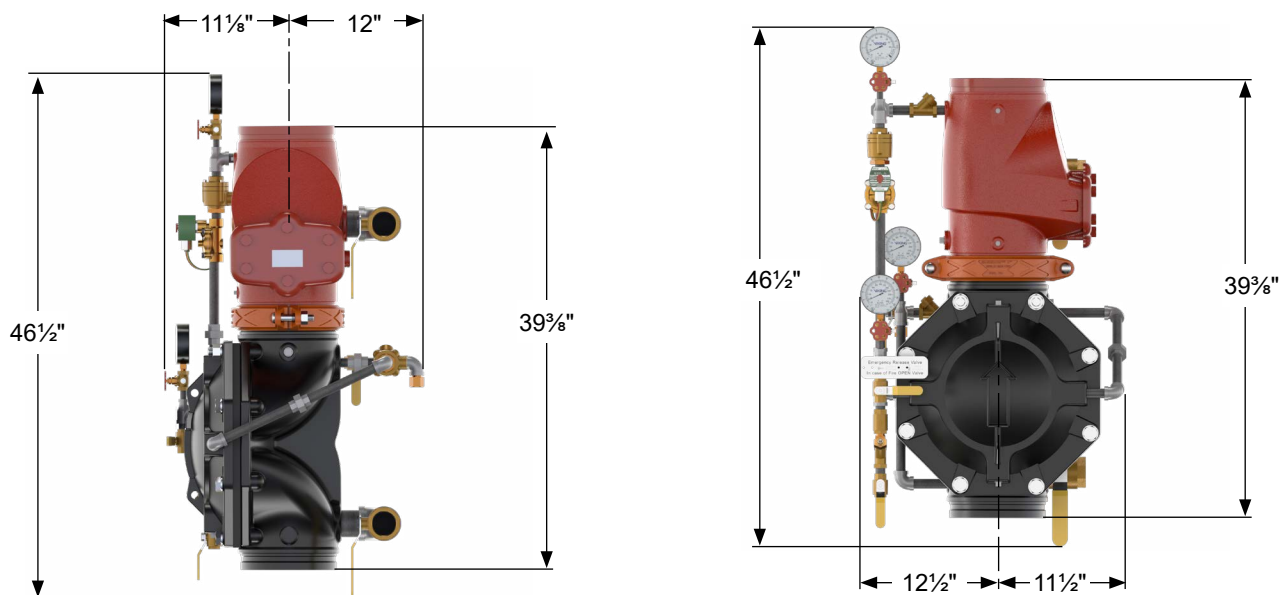

**Figure 21: Dimensions - 8" Loose/Pre-trimmed**



# TECHNICAL DATA

**MODEL VXD DOUBLE INTERLOCKED  
PREACTION SYSTEM WITH  
ELECTRIC/PNEUMATIC RELEASE**

The Viking Corporation, 210 N Industrial Park Drive, Hastings MI 49058  
 Telephone: 269-945-9501 Technical Services: 877-384-5464 Fax: 269-818-1680 Email: techsvcs@vikingcorp.com  
 Visit the Viking website for the latest edition of this technical data page [www.vikinggroupinc.com](http://www.vikinggroupinc.com)

