

	<h2 style="margin: 0;">TECHNICAL DATA</h2>	<p style="margin: 0;"><b>InstaSeal®</b> <b>WELDED SPRINKLER FITTINGS</b> <b>MODEL IS-W2 1"</b></p>
---	--	--

The Viking Corporation, 5150 Beltway Dr. SE Caledonia, MI 49316  
 Telephone: 269-945-9501 Technical Services: 877-384-5464 Fax: 269-818-1680 Email: techsvcs@vikingcorp.com  
 Visit the Viking website for the latest edition of this technical data page [www.vikinggroupinc.com](http://www.vikinggroupinc.com)

**1. DESCRIPTION**

The Viking InstaSeal® welded sprinkler fittings are designed to allow hand-tightening of threaded sprinklers. The gasket seals the connection upon sprinkler installation and eliminates the need for additional sealants (PTFE tape or thread sealant) typically used for sprinkler installation.

**2. LISTINGS AND APPROVALS**



cULus Listed: EX28508



FM Approved: Class 1920

**3. TECHNICAL DATA**

Available since 2023

**Materials of Construction:**

Fitting: ASTM A106 or AISI 1010  
 Gasket: EPDM Rubber  
 Alignment tool: Nylon reinforced plastic  
 Cap: LDPE

**Pressure rating: 175 psi (12 bar)**

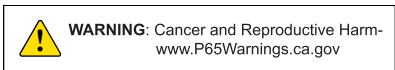

**Ordering Information**

Viking InstaSeal® fittings are pre-fabricated and welded onto the pipe. Please contact Viking SupplyNet for more information. These are custom order products and can not be returned or refunded.



**NOTE: Product appearance may vary.**

Ordering Information	
<b>Available sizes</b> (Outlet size x pipe size)	1" NPT x 2" - 2½" 1" NPT x 2½" - 3"
<b>Pipe</b>	Scheduled 10, 30, and 40
<b>Flow Pipe</b>	Bull Moose Eddy Flow, Wheatland MegaFlow, Wheatland MegaFlow GF, Nucor HydroFlow, Borusan Easy Flow, and Youngstown Fire-Flo
Accessories	
<b>Gasket(s), tool, and tool kit</b>	Gasket(s): <b>25712M/W</b> ***This part number is for 1 gasket. Specify the desired quantity when ordering.***  Push-rods: <b>26203-1</b> Includes 2 Push-rod tools. Used for installing gaskets. Good for up to 500 installations  Tool Kit: <b>26595</b> Refer to Figure 2. Kit includes 1 Gasket removal tool, 1 Push-rod, 1 Nozzle, and 6 gaskets (1")
<b>Alignment tool</b>	<b>24838</b> - For use with ¾" and 1" sprinklers, refer to Figure 2. Fits ONLY ESFR sprinklers. *** Not included with kit 26595.***  <b>26834</b> - For use with the VK595 (1" NPT). Refer to Figures 3B and 3D.



**TECHNICAL DATA**

**InstaSeal®  
WELDED SPRINKLER FITTINGS  
MODEL IS-W2 1"**

The Viking Corporation, 5150 Beltway Dr. SE Caledonia, MI 49316  
 Telephone: 269-945-9501 Technical Services: 877-384-5464 Fax: 269-818-1680 Email: techsvcs@vikingcorp.com  
 Visit the Viking website for the latest edition of this technical data page www.vikinggroupinc.com

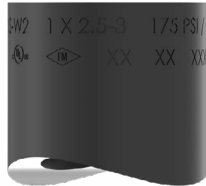

MARKINGS	
Model	VK IS-W2
Date of manufacture	[mm/yyyy]
Outlet size X pipe size range	1" NPT x 2" - 2½" 1" NPT x 2½" - 3"
Maximum pressure rating	175 PSI (12 BAR)

*\*Dimensions are approximate.*

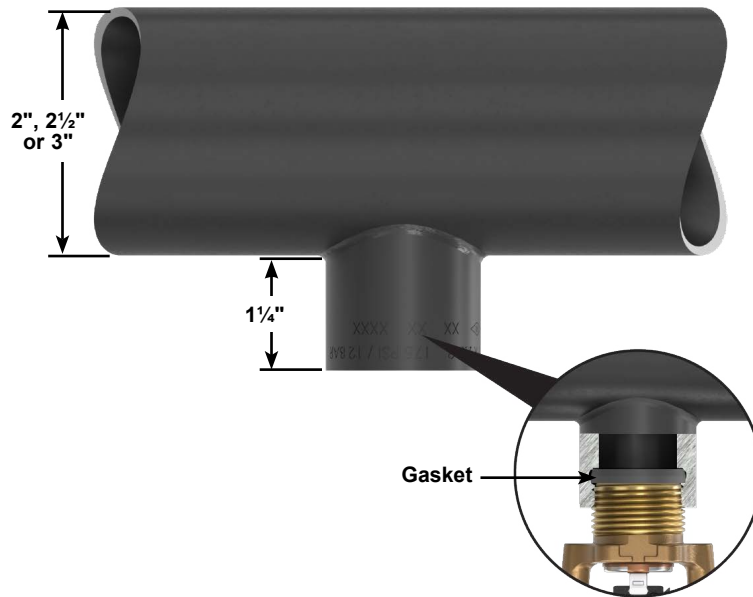

**NOTICE:**

**Install ONLY 1" NPT threaded sprinklers directly into the fitting.**

**The 1" NPT pipe adapter bushing must be installed before installing any threaded 1" NPT pipe or other devices.  
 Refer to Figure 3.**

**Figure 1: Markings and Dimensions**



**TECHNICAL DATA**

**InstaSeal®  
WELDED SPRINKLER FITTINGS  
MODEL IS-W2 1"**

The Viking Corporation, 5150 Beltway Dr. SE Caledonia, MI 49316  
Telephone: 269-945-9501 Technical Services: 877-384-5464 Fax: 269-818-1680 Email: techsvcs@vikingcorp.com  
Visit the Viking website for the latest edition of this technical data page [www.vikinggroupinc.com](http://www.vikinggroupinc.com)

**Gasket Removal Tool**



**Nozzle**



**Push-rod**



**Gasket**

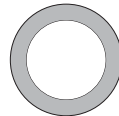

**Alignment Tool  
(NOT INCLUDED WITH TOOL KIT)**



**Figure 2: Accessories**

**TECHNICAL DATA****InstaSeal®  
WELDED SPRINKLER FITTINGS  
MODEL IS-W2 1"**

The Viking Corporation, 5150 Beltway Dr. SE Caledonia, MI 49316

Telephone: 269-945-9501 Technical Services: 877-384-5464 Fax: 269-818-1680 Email: techsvcs@vikingcorp.com

Visit the Viking website for the latest edition of this technical data page [www.vikinggroupinc.com](http://www.vikinggroupinc.com)

**NOTICE:** Installing any device that is not a Viking sprinkler into the IS-W2 fitting may cause leaks. Prior to installing devices other than sprinklers, install the pipe adapter bushing as shown below.

Prior to installing any pipe or device that is not a sprinkler:

1. Thread the pipe adapter bushing into the fitting.
2. Tighten the pipe adapter bushing completely using a pipe wrench.
3. Connections made into the adapter bushing after installation into the IS-W2 will still require normal end preparation (for example, PTFE tape).

**Adapter Bushing 24551**

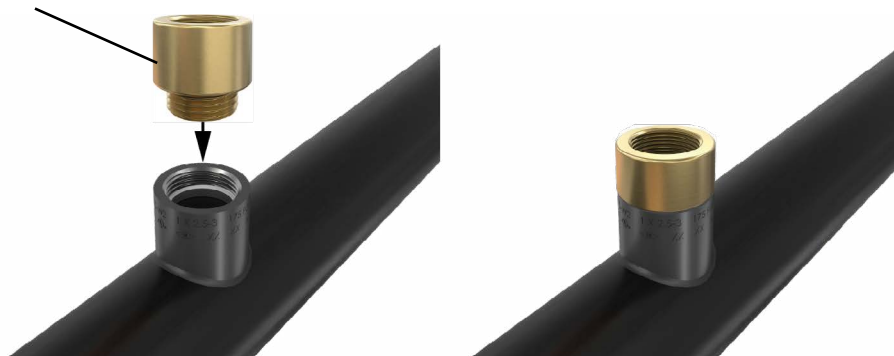

**Figure 3: Pipe Adpater Bushing Installation**



## TECHNICAL DATA

InstaSeal®  
WELDED SPRINKLER FITTINGS  
MODEL IS-W2 1"

The Viking Corporation, 5150 Beltway Dr. SE Caledonia, MI 49316

Telephone: 269-945-9501 Technical Services: 877-384-5464 Fax: 269-818-1680 Email: techsvcs@vikingcorp.com

Visit the Viking website for the latest edition of this technical data page [www.vikinggroupinc.com](http://www.vikinggroupinc.com)

### 4. INSTALLATION

Refer to appropriate NFPA, FM Global, and/or any other applicable installation standards. Also refer to the sprinkler's technical data sheet for information regarding installation of the sprinkler.

For handling the VK595 installation cap, refer to Figure 3C.

#### NOTICE

**Over-tightening the sprinkler will deform the gasket and cause leaks.**

- Do not tighten the sprinkler more than 360 degrees (1 full turn) from initial gasket contact.
- Install the sprinkler by hand or by using the InstaSeal® alignment tool.
- **DO NOT USE THE SPRINKLER'S STANDARD METAL INSTALLATION WRENCH.**
- Do not exceed the maximum torque specified for the sprinkler. Refer to the sprinkler's documentation

#### Seating the Sprinkler

1. Remove the integrity protective cap from the IS-W2 fitting.

**NOTE: DO NOT COMPRESS THE GASKET DURING THE FOLLOWING TWO STEPS.**

2. Slowly and gently thread the sprinkler into the fitting **by hand** until you feel resistance (indicates gasket contact).
3. **PAUSE** upon initial contact with gasket and take note of the position of the sprinkler's frame arms relative to the pipe before proceeding.



Figure 3A: Seating the Sprinkler



**TECHNICAL DATA**

**InstaSeal®  
WELDED SPRINKLER FITTINGS  
MODEL IS-W2 1"**

The Viking Corporation, 5150 Beltway Dr. SE Caledonia, MI 49316  
 Telephone: 269-945-9501 Technical Services: 877-384-5464 Fax: 269-818-1680 Email: techsvcs@vikingcorp.com  
 Visit the Viking website for the latest edition of this technical data page www.vikinggroupinc.com

**Compressing the Gasket**

4. Tighten the sprinkler 180 degrees (1/2 turn) for gasket seal. **Minimum recommended torque: approximately 3 ft-lbs.**

**Note: The alignment tool may be used to achieve gasket sealing.**

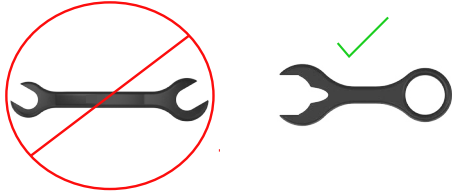

5. If desired, the sprinkler may be tightened up to an additional 180 degrees (1/2 turn) in order to align the sprinkler frame arms parallel with the pipe. **Maximum recommended torque: approximately 8 ft-lbs.**
6. Remove the sprinkler's protective cap before placing the system in service.

**NOTICE: DO NOT USE THE SPRINKLER'S STANDARD METAL INSTALLATION WRENCH  
 INSTALL THE SPRINKLER BY HAND OR USE THE InstaSeal® ALIGNMENT TOOL ONLY!**



**Figure 3B: Removing the Cap and Aligning the Sprinkler Frame Arms**

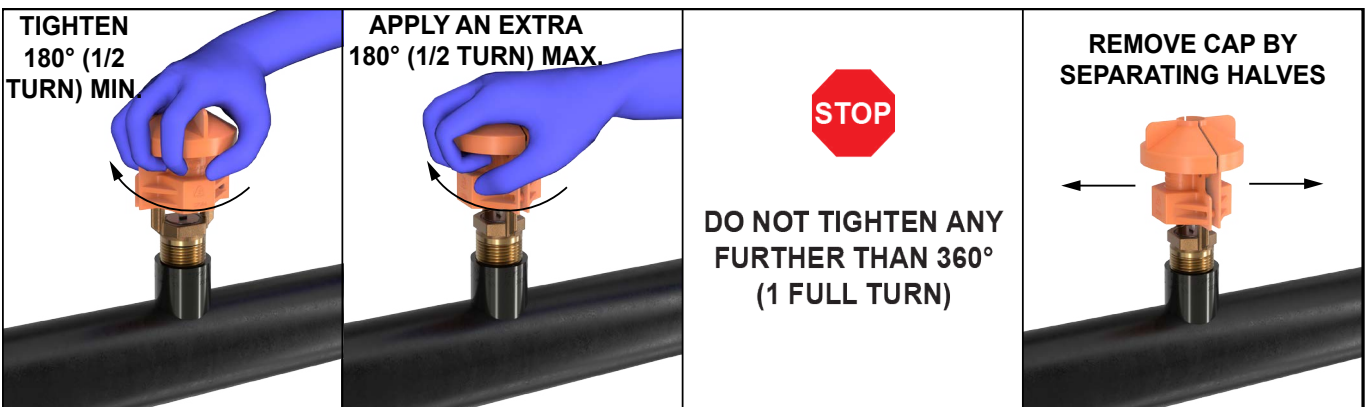

**Figure 3C: Seating the Sprinkler - VK595**



## TECHNICAL DATA

InstaSeal®  
WELDED SPRINKLER FITTINGS  
MODEL IS-W2 1"

The Viking Corporation, 5150 Beltway Dr. SE Caledonia, MI 49316

Telephone: 269-945-9501 Technical Services: 877-384-5464 Fax: 269-818-1680 Email: techsvcs@vikingcorp.com

Visit the Viking website for the latest edition of this technical data page [www.vikinggroupinc.com](http://www.vikinggroupinc.com)

### 5. GUARANTEE

For details of warranty, refer to Viking's current list price schedule or contact Viking directly.

### 6. INSPECTIONS, TESTING, AND MAINTENANCE

#### NOTICE

The owner is responsible for maintaining the fire protection system and devices in proper operating condition. For minimum maintenance and inspection requirements, refer to NFPA 25 for Inspection, Testing and Maintenance requirements. In addition, the Authority Having Jurisdiction may have additional maintenance requirements that must be followed.

#### Inspections

The InstaSeal® fittings should be inspected and the gasket replaced any time a sprinkler is removed.

#### Testing

Refer to NFPA 25 for Inspection, Testing and Maintenance requirements.

#### Maintenance

The gasket must be replaced whenever a sprinkler is removed.

#### Replacing the Gasket (see Figures 2 and 4)

1. Verify that the system has been removed from service. Refer to the system's documentation.
2. Remove the sprinkler.
3. Remove the old gasket using the pick tool (Figure 2, #1).

**NOTE: DIP THE NEW GASKET IN WATER TO LUBRICATE.**

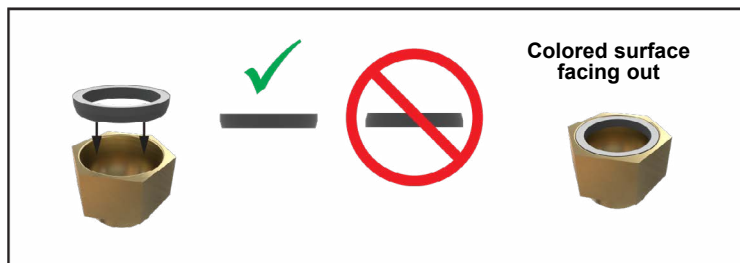

**Figure 4A: Inserting Gasket into Nozzle**

4. Place new gasket into the nozzle with the chamfered edge going in first (the surface is colored to properly orient the gasket within the nozzle).
5. Place the nozzle/gasket into the IS-W2 fitting.
6. Line up the insertion tool on the gasket surface ensuring the contact is uniform.
7. Press straight inward on the insertion tool until it contacts the mechanical stop (Figure 2, #5).
8. Remove the tool and install a new sprinkler.



**Figure 4B: Inserting Gasket into IS-W2 Fitting**



## TECHNICAL DATA

InstaSeal®  
WELDED SPRINKLER FITTINGS  
MODEL IS-W2 1"

The Viking Corporation, 5150 Beltway Dr. SE Caledonia, MI 49316

Telephone: 269-945-9501 Technical Services: 877-384-5464 Fax: 269-818-1680 Email: techsvcs@vikingcorp.com

Visit the Viking website for the latest edition of this technical data page [www.vikinggroupinc.com](http://www.vikinggroupinc.com)

### 6.1 Repairing a Fitting with a Leak at the Weld

#### **⚠ WARNING**

Any system maintenance that involves placing a control valve or detection system out of service may eliminate the fire protection capabilities of that system. Prior to proceeding, notify all Authorities Having Jurisdiction. Consideration should be given to employment of a fire patrol in the affected areas.

If a leak develops at the weld, follow the procedure below to repair the fitting.

1. Verify that the system has been removed from service. Refer to the system's documentation.
2. Remove the sprinkler from the fitting according to the manufacturer's instructions.
3. Refer to Figure 2. Remove the gasket from the fitting using the gasket removal tool (or comparable tool).
4. Discard the old gasket.
5. Perform any necessary repairs.
6. Refer to Figure 5. Place new gasket (a) into the nozzle (b) with the white colored surface facing out and the chamfered edge going in first (the surface is colored to properly orient the gasket within the nozzle) then place the nozzle into the outlet (c) as shown.

**IMPORTANT: The gasket MUST BE NEW.**

7. Line up the insertion tool on the gasket surface ensuring the contact is uniform.
8. Press straight on the insertion tool (d) until it contacts the mechanical stop fully seating the nozzle onto the welded fitting.
9. Remove the tool and install a new sprinkler. Refer to section 4 in this document for applicable installation procedure.