



TECHNICAL DATA

SOLENOID VALVES RATED TO 250 PSI (17.2 BAR)

The Viking Corporation, 210 N Industrial Park Drive, Hastings MI 49058

Telephone: 269-945-9501 Technical Services: 877-384-5464 Fax: 269-818-1680 Email: techsvcs@vikingcorp.com

Visit the Viking website for the latest edition of this technical data page www.vikinggroupinc.com

1. DESCRIPTION

The high pressure solenoid valve is a two-way type with one inlet and one outlet. It is a packless, internal pilot operated valve, suitable for use in releasing water pressure from the priming chamber of Viking Model E, F, G and VXD Series Deluge Valves and Viking Model H and J Series Flow Control Valves. The solenoid valve has floating diaphragm construction, which requires a minimum pressure drop across the valve to operate properly. The valves are available with a voltage rating of 24V DC in a normally closed or normally open configuration. These solenoid valves are for use with system control units that are listed and/or approved for releasing service for water based fire protection systems.

Features

- Normally Closed or Normally Open
- 24 VDC
- Easy to clean
- Body Style: Straight through
- NEMA 1 through 9. (See Table 1)
- Required Accessories: A 50 mesh strainer must be installed on the inlet side of the valve at the priming line connection. This strainer is included as part of the Model E, F, G and VXD Deluge Valve Trim and Model H or J Flow Control Valve Trim.

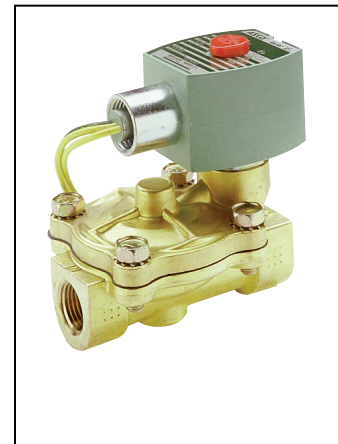

2. LISTINGS AND APPROVALS (see table 1 for specific model approvals)



UL Listed



FM Approved



CSA Certified



CE Directives Applicable



WARNING: Cancer and Reproductive Harm - www.P65Warnings.ca.gov



AVERTISSEMENT: Cancérogène et toxique pour la reproduction - www.P65Warning.ca.gov

3. TECHNICAL DATA

Specifications

Coil:

- Class F for Part Numbers 11601, 11602 and 13215.
- Class H for Part Numbers 13843 and 13844, Continuous Duty

Maximum Operating Pressure:

- 250 psi (17.2 bar) for Part Numbers 11601, 11602 and 13215.
- 300 psi (20.6 bar) for Part Numbers 13843 and 13844.

See Table 1 for enclosure descriptions and recommended ambient temperatures.

Material Standards

Body: Brass with 1/2" (15 mm) NPT connections

Seals and Discs: Buna N

Core Tube: 305 Stainless Steel

Core and Plugnut: 430F Stainless Steel

Springs: 302 Stainless Steel

Table 1 - Part Numbers and Specifications

| Description | Model | Part Number | For Viking System | Orifice | Wattage | DC Current | Max. Ambient Temp. | Cv Factor | Listings & Approvals | | | | |
|--|--------|-------------|------------------------------|---------|---------|------------|--------------------|-----------|----------------------|------------------|------------------|------------------|-------------------|
| | | | | | | | | | UL | CSA | FM | LPCB | CE |
| Normally Closed NEMA 1,2,3,3S,4,4X ¹ | 24 VDC | 11601 | Deluge & Preaction, SureFire | 3/4" | 9.0 DC | 338 mA | 130 °F (54 °C) | 4.0 | Yes ² | Yes ⁶ | Yes ⁹ | Yes ⁹ | Yes ¹⁰ |
| Normally Closed Explosion Proof NEMA 3,3S,4,4X,6,6P,7,9 ¹ | 24 VDC | 11602 | | 3/4" | 9.0 DC | 338 mA | 130 °F (54 °C) | 4.0 | Yes ³ | Yes ⁷ | Yes ⁹ | Yes ⁹ | -- |
| Normally Open NEMA 1,2,3,3S,4,4X ¹ | 24 VDC | 13215 | Surefire | 3/4" | 9.0 DC | 338 mA | 130 °F (54 °C) | 4.0 | Yes ⁴ | Yes ⁶ | Yes ⁹ | Yes ⁹ | Yes ¹⁰ |
| Normally Closed NEMA 1,2,3,3S,4,4X ¹ | 24 VDC | 13843 | Deluge & Preaction | 5/8" | 1.5 DC | 140 mA | 140 °F (60 °C) | 4.0 | Yes ⁵ | Yes ⁸ | Yes ⁹ | -- | Yes ¹⁰ |
| Normally Closed Explosion Proof NEMA 3,3S,4,4X,6,6P,7,9 ¹ | 24 VDC | 13844 | | 5/8" | 1.5 DC | 140 mA | 140 °F (60 °C) | 4.0 | Yes ⁵ | Yes ⁸ | Yes ⁹ | -- | -- |

Footnotes

1. Enclosure types: 1 - General Purpose, 2 - Drip-Proof, 3 and 3s - Rain Tight, 4 and 4X - Water Tight, 6 and 6P - Submersible, 7 - Explosion Proof Class I Groups A, B, C and D, 9 - Dust Ignition Proof Class II Groups E, F & G.
2. UL Listed - VLTR file MP618 Ordinary, under ASCO, L.P. HV274060007
3. UL Listed - YTSX file E25549 Hazardous, under ASCO, L.P. HV274060008
4. UL Listed - YIOZ file MP618 Ordinary, under ASCO, L.P. HV283852001
5. UL Listed - VLTR EX1130
6. cCSAus Certified - file 10381, Ordinary, under ASCO, L.P. HV274060007 and HV283852001
7. cCSAus Certified - file 13976, Hazardous, under ASCO, L.P. HV274060008
8. cCSAus Certified
9. FM and LPCB Approved - as part of Viking Deluge Valves
10. CE Directives Applicable (EMC 2014/30/EU)



TECHNICAL DATA

SOLENOID VALVES RATED TO 250 PSI (17.2 BAR)

The Viking Corporation, 210 N Industrial Park Drive, Hastings MI 49058

Telephone: 269-945-9501 Technical Services: 877-384-5464 Fax: 269-818-1680 Email: techsvcs@vikingcorp.com

Visit the Viking website for the latest edition of this technical data page www.vikinggroupinc.com

4. INSTALLATION

1. Check nameplate for correct unit, including voltage and mode of operation. Follow all installation and maintenance instructions enclosed with the valve.
2. Standard solenoids may be mounted in any position. However, for optimum life and performance, solenoids should be mounted vertically and upright with the coil upright.
3. A 50 mesh strainer is required on the inlet side of the valve at the priming line connection. This strainer is included as part of the Model E, F, G and VXD Deluge Valve Trim and Model H or J Flow Control Valve Trim. Install the strainer as indicated on Viking's trim drawing. Install the solenoid according to markings on the valve body. Apply pipe-joint compound sparingly to male pipe threads only. If applied to valve threads, it may enter the valve and cause operation difficulty or leakage. Avoid putting pipe compound on first two male threads as well.
4. The unit must be wired in accordance with local and national electrical codes. For valves equipped with water tight enclosures, the electrical fittings must be approved for use in the hazardous location.
5. Upon completing the installation, the entire system must be tested for proper operation. See system description and testing instructions for additional information.

5. OPERATION

The solenoid valve is an internal pilot operated valve with pilot and bleed orifices utilizing line pressure for operation. Normally closed, de-energized valves open when energized. Power is applied to the solenoid coil, causing the solenoid core to lift, opening the pilot orifice to the outlet side of the valve. This relieves pressure on the top side of the diaphragm and allows the line pressure to open the valve. When de-energized, the solenoid core reseals the pilot orifice, allowing the line pressure to build above the diaphragm, closing the valve.

Normally closed solenoid valves are commonly used as releases for Viking deluge and flow control valves. Opening the solenoid valve allows the deluge or flow control valve to open.

NOTE: When using a normally closed solenoid valve as a release, a system will not operate automatically on total loss of power. For this reason, it is recommended and normally required that an emergency battery back-up, supervised power supply be provided to maintain fire protection during interruptions of the main power system and to meet the requirements of appropriate Authorities Having Jurisdiction.

6. INSPECTIONS, TESTS AND MAINTENANCE

NOTICE

The owner is responsible for maintaining the fire protection system and devices in proper operating condition. For minimum maintenance and inspection requirements, refer to recognized standards such as those produced by NFPA, LPC, and VdS which describe care and maintenance of sprinkler systems. In addition, the Authority Having Jurisdiction (AHJ) may have additional maintenance, testing and inspection requirements which must be followed.

⚠ WARNING

Any system maintenance or testing that involves placing a control valve or detection system out of service may eliminate the fire protection of that system. Prior to proceeding, notify all Authorities Having Jurisdiction. Consideration should be given to employment of a fire patrol in the affected area. Failure to follow these instructions could cause improper system operation, resulting in serious personal injury and/or property damage.

⚠ AVERTISSEMENT

Toute maintenance du système nécessitant la mise hors service d'une vanne de régulation ou d'un système de détection altérera les capacités de protection contre l'incendie de ce système. Avant de poursuivre, les procédures de fonctionnement en mode dégradé appropriées selon la norme NFPA 25 doivent être suivies avec l'information de toutes les autorités compétentes. Il faudrait envisager de faire appel à une patrouille de pompiers dans les zones touchées.

Si ces instructions ne sont pas respectées, cela pourrait entraîner un fonctionnement incorrect du système, entraînant des blessures graves et / ou des dégâts matériels.



TECHNICAL DATA

SOLENOID VALVES
RATED TO 250 PSI (17.2 BAR)

The Viking Corporation, 210 N Industrial Park Drive, Hastings MI 49058

Telephone: 269-945-9501 Technical Services: 877-384-5464 Fax: 269-818-1680 Email: techsvcs@vikingcorp.com

Visit the Viking website for the latest edition of this technical data page www.vikinggroupinc.com

⚠ WARNING

Prior to operating the solenoid valve, be sure to close the system control valve to avoid unintentional operation of the deluge valve.

⚠ AVERTISSEMENT

AVANT D'UTILISER L'ELECTROVANNE, ASSUREZ-VOUS DE FERMER LA VANNE DE CONTRÔLE DU SYSTÈME POUR ÉVITER LE FONCTIONNEMENT NON INTENTIONNEL DE LA VANNE DELUGE.

Inspections:

It is imperative that the system is inspected and tested on a regular basis in accordance with NFPA 25. The frequency of the inspections may vary due to contaminated water supplies, corrosive water supplies, or corrosive atmospheres. In addition, the alarm devices, detection systems, or other connected trim may require a more frequent schedule. Refer to the system description and applicable codes for minimum requirements.

1. The valve must be operated at least monthly. The valve must open and close freely. When open, the water flow must be clear and clean at the proper flow rate. When closed, a total water shut-off must be observed. After the test, the strainer must be cleaned. Prior to cleaning the strainer, the priming line valve must be closed and the priming line depressurized. After the strainer is cleaned, the priming line valve must be reopened.
2. The valve must be inspected at least monthly for cracks, corrosion, leakage, etc., and cleaned, repaired, or replaced as necessary.
3. At least annually, the valve diaphragms and seats must be inspected and, if necessary, repaired or replaced.

⚠ WARNING

Close system control valve, turn off power supply, and depressurize valve before disassembling valve. It is not necessary to remove the valve from the pipe line to make inspections.

⚠ AVERTISSEMENT

FERMEZ LA VANNE DE COMMANDE DU SYSTÈME, COUPEZ L'ALIMENTATION ÉLECTRIQUE ET DÉPRESSURISEZ LA VANNE AVANT DE LA DÉMONTER. IL N'EST PAS NÉCESSAIRE D'ENLEVER LA VANNE DE LA TUYAUTERIE POUR FAIRE DES INSPECTIONS.

4. When lubricating valve components, use a high grade silicone grease (Dow Corning® 111 Compound Lubricant or equal).
5. When reassembling, tighten parts to torque values indicated in ASCO's maintenance instructions (packed with valve).
6. After maintenance is completed, operate the valve a few times to be sure of proper operation. A metallic "click" signifies the solenoid is operating.
7. It is recommended that the valve be replaced at seven-year intervals. Shorter intervals may be required if the valve is subject to corrosive water supplies or atmospheres.
8. All service must be performed by qualified personnel. Upon completion of inspections or replacement of the valve, the entire system must be checked for proper operation. See appropriate system description and testing instructions for additional information.

7. AVAILABILITY

The Viking Solenoid Valve is available through a network of domestic and international distributors. See the Viking Corp. Web site for closest distributor or contact The Viking Corporation.

8. GUARANTEE

For details of warranty, refer to Viking's current list price schedule or contact Viking directly.



TECHNICAL DATA

SOLENOID VALVES
RATED TO 250 PSI (17.2 BAR)

The Viking Corporation, 210 N Industrial Park Drive, Hastings MI 49058
 Telephone: 269-945-9501 Technical Services: 877-384-5464 Fax: 269-818-1680 Email: techsvcs@vikingcorp.com
 Visit the Viking website for the latest edition of this technical data page www.vikinggroupinc.com

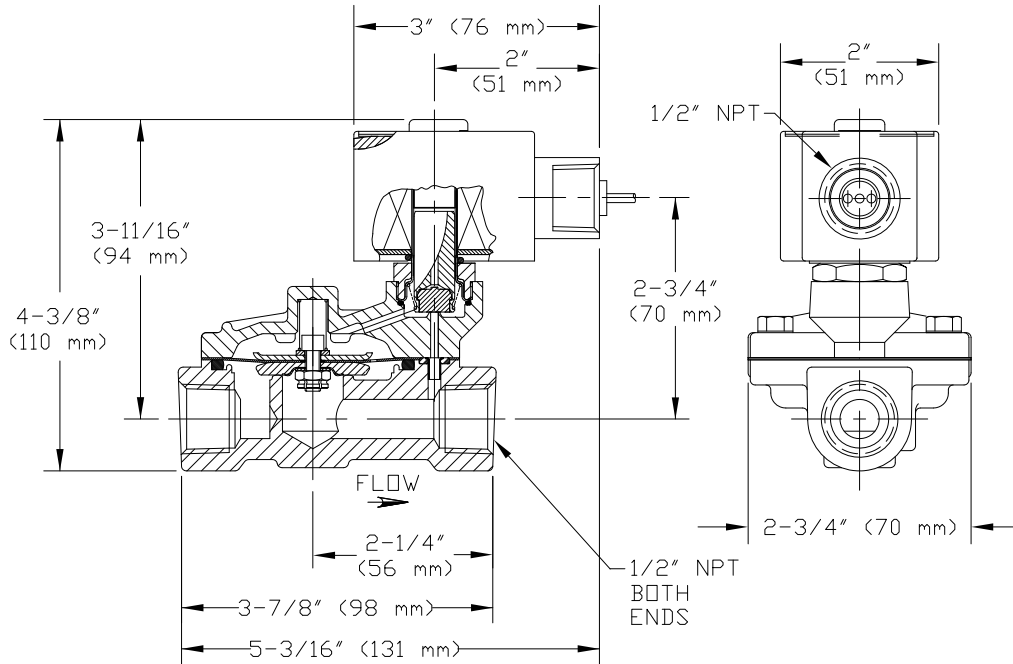

Figure 1
Dimensions for Part Numbers 11601, 11602 and 13215

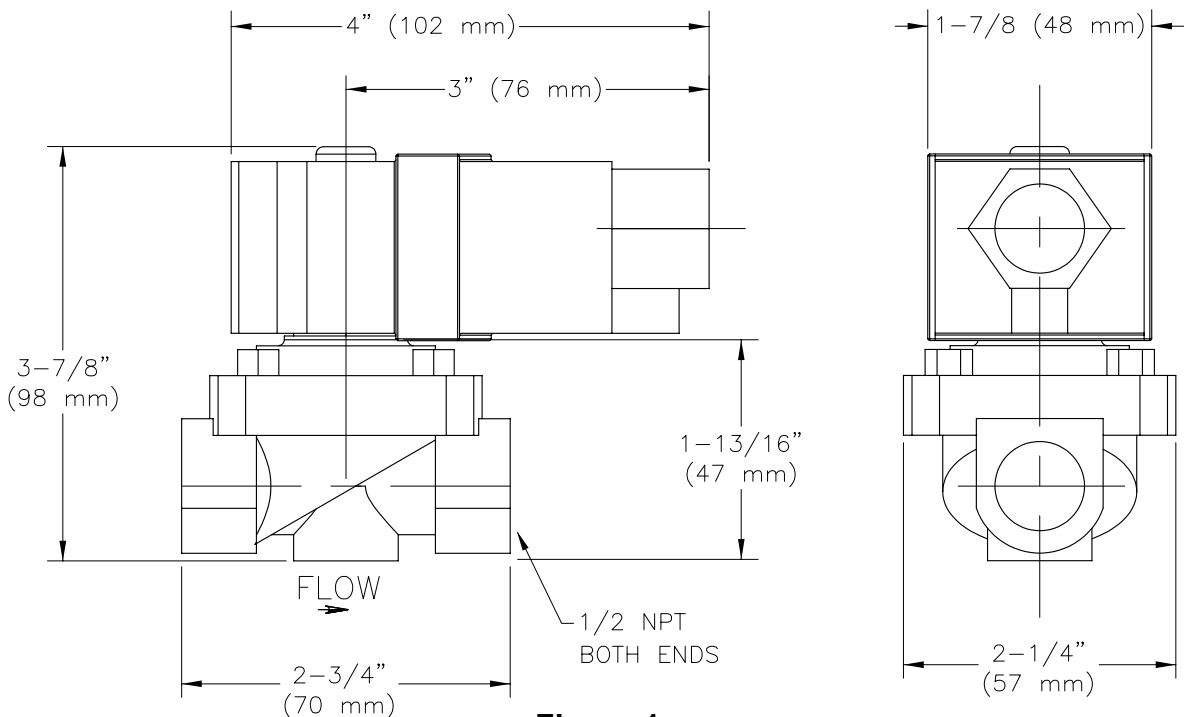

Figure 1
Dimensions for Part Numbers 13843 and 13844