



## TECHNICAL DATA

## MICROMATIC® SPECIAL RESPONSE SPRINKLERS

The Viking Corporation, 210 N Industrial Park Drive, Hastings MI 49058

Telephone: 269-945-9501 Technical Services: 877-384-5464 Fax: 269-818-1680 Email: techsvcs@vikingcorp.com

### 1. DESCRIPTION

Viking Micromatic® Special Response Sprinklers are small, thermosensitive, glass-bulb spray sprinklers available in several different finishes, temperature ratings, and K-Factors to meet design requirements.

### 2. LISTINGS AND APPROVALS



**VdS Approved:** Certificate G4060052, G4060053, G4960014, G4960015, G4960016, G4960017, G4960018, G4960019, G4960024, and G4960025



**CE Certified:** Standard EN 12259-1, EC-certificate of conformity 0786-CPD-40134, 0786-CPD-40135, 0786-CPD-40136, 0786-CPD-0138, 0786-CPD-40139, 0786-CPD-40140, 0786-CPD-40174, 0786-CPD-40175, 0786-CPD-40176, 0786-CPD-40178, 0786-CPD-40179, and 0786-CPD-40180

**NOTE:** Other International approval certificates are available upon request. Refer to the Approval Chart on page 125c.



### 3. TECHNICAL DATA

#### Specifications:

Available since 1996.

Minimum Operating Pressure: 7 PSI (0.5 bar)\*

Maximum Working Pressure: 175 PSI (12 bar).

Factory tested hydrostatically to 500 PSI (34.5 bar)

Testing: U.S.A. Patent No. 4,831,870

Thread size: Refer to the Approval Chart

Nominal K-Factor: Refer to the Approval Chart

Response Time Index (RTI): 50-80 (ms)<sup>½</sup>

Glass-bulb fluid temperature rated to -65 °F (-55 °C)

Overall Length: Refer to the Approval Chart

\*NFPA 13 installs require a minimum of 7 psi (0.5 bar). The minimum operating pressure for CE Approvals ONLY is 5 psi (0.35 bar).

#### Material Standards:

Frame Casting: Brass UNS-C84400

Deflector: Phosphor Bronze UNS-C51000, Copper UNS-C19500, or Brass UNS-C26000 for Sprinklers 09224 and 09228.

Brass UNS-C26000 for all other sprinklers

Bulb: Glass, nominal 4 mm or 5 mm diameter

Belleville Spring Sealing Assembly: Nickel Alloy, coated on both sides with Polytetrafluoroethylene (PTFE) Tape

Screw: Brass UNS-C36000

Pip Cap: Leaded Bronze UNS-C31600 or Brass UNS-C31400, or

Pip Cap and Insert Assembly: Copper UNS-C11000 and Stainless Steel UNS-S30400

Ejector Spring (for Sprinkler 09229): 17-7 Stainless Steel

For Polyester Coated Sprinklers: Belleville Spring is Exposed

**Ordering Information:** (Also refer to the current Viking price list.)

Order Micromatic® Special Response Pendent Sprinklers by first adding the appropriate suffix for the sprinkler finish and then the appropriate suffix for the temperature rating to the sprinkler base part number.

Finish Suffix: Brass = A, Chrome = F, White Polyester = M-/W

Temperature Suffix: 155 °F (68 °C) = B, 175 °F (79 °C) = D, 200 °F (93 °C) = E, 286 °F (141 °C) = G

For example, sprinkler VK134 with a 1/2" thread, Brass finish and a 155 °F (68 °C) temperature rating = Part No. 09224AB

**Available Finishes and Temperature Ratings:** Refer to Table 1.

**Accessories:** (Also refer to the "Sprinkler Accessories" section of the Viking data book.)

#### Sprinkler Wrenches:

A. Standard Wrench: Part No. 10896W/B (available since 2000).

B. Wrench for Recessed Pendent Sprinklers: Part No. 16036W/B\*\* (available since 2011)

C. Optional Protective Sprinkler Cap Remover/Escutcheon Installer Tool\*\*\* Part No. 15915 (available since 2010.)

\*\*A ½" ratchet is required (not available from Viking).

\*\*\*Allows use from the floor by attaching a length of 1" diameter CPVC tubing to the tool. Ideal for sprinkler cabinets. Refer to Bulletin F\_051808.

Viking Technical Data may be found on  
The Viking Corporation's Web site at  
<http://www.vikinggroupinc.com>.  
The Web site may include a more recent  
edition of this Technical Data Page.



## TECHNICAL DATA

## MICROMATIC® SPECIAL RESPONSE SPRINKLERS

The Viking Corporation, 210 N Industrial Park Drive, Hastings MI 49058

Telephone: 269-945-9501 Technical Services: 877-384-5464 Fax: 269-818-1680 Email: techsvcs@vikingcorp.com

### Sprinkler Cabinets:

- A. Six-head capacity: Part No. 01724A (available since 1971)
- B. Twelve-head capacity: Part No. 01725A (available since 1971)

## 4. INSTALLATION

**WARNING:** Viking sprinklers are manufactured and tested to meet the rigid requirements of approving agencies. The sprinklers are to be installed in accordance with the latest edition of Viking technical data, the latest standards of NFPA, FM Global, LPCB, APSAD, VdS, or other similar organizations, and also with the provisions of governmental codes, ordinances, and standards whenever applicable. The use of Special Response sprinklers may be limited due to occupancy and hazard. Refer to the Authority Having Jurisdiction prior to installation. Deviation from the standards or any alteration to the sprinkler after it leaves the factory including, but not limited to: painting, plating, coating, or modification, may render the sprinkler inoperative and would automatically nullify the approval and any guarantee made by The Viking Corporation.

- A. Sprinklers must be handled with care. They must be stored in a cool, dry place in their original shipping container. Never install sprinklers that have been dropped, damaged, or exposed to temperatures exceeding the maximum ambient temperature allowed (refer to Table 1). Never install any glass-bulb sprinkler if the bulb is cracked or if there is a loss of liquid from the bulb. Any sprinkler with a loss of liquid from the glass bulb should be destroyed immediately.
- B. Sprinklers must be protected from mechanical damage. Sprinklers subject to mechanical damage must be protected with an approved sprinkler guard.
- C. Use only sprinklers listed as corrosion resistant when subject to corrosive environments. When installing corrosion-resistant sprinklers, take care not to damage the corrosion-resistant coating. Use only the special wrench designed for installing coated and recessed Viking sprinklers (any other wrench may damage the unit).
- D. Use care when locating sprinklers near fixtures that can generate heat. Do not install sprinklers where they could be exposed to temperatures exceeding the maximum recommended ambient temperature for the temperature rating used.
- E. Wet-pipe systems must be provided with adequate heat. Sprinklers supplied from dry systems in areas subject to freezing must be listed dry sprinklers, or upright or horizontal sidewall sprinklers installed so that water is not trapped. For dry systems, pendent sprinklers and sidewall sprinklers installed on return bends are permitted, where the sprinklers, return bend, and branch line piping are in an area maintained at or above 40 °F (4 °C). When installing Special Response Sprinklers on dry systems, refer to the installation standards and the Authority Having Jurisdiction.
- F. Before installation, be sure to have the appropriate sprinkler model and style, with the correct orifice size, temperature rating, and response characteristics. The sprinklers must be installed after the piping is in place to prevent mechanical damage. Keep sprinklers with protective caps or shields contained within the caps or shields during installation and testing, and any time the sprinkler is shipped or handled.
  - 1. Install the escutcheon, (if used) which is designed to thread onto the external threads of the sprinkler. Refer to the "Sprinkler Accessories" section of the data book for approved escutcheons and other accessories.

**TABLE 1: AVAILABLE SPRINKLER TEMPERATURE RATINGS AND FINISHES**

| Sprinkler Temperature Classification | Sprinkler Nominal Temperature Rating <sup>1</sup> | Maximum Ambient Ceiling Temperature <sup>2</sup> | Bulb Color |
|--------------------------------------|---|--|------------|
| Ordinary                             | 155 °F (68 °C)                                    | 100 °F (38 °C)                                   | Red        |
| Intermediate                         | 175 °F (79 °C)                                    | 150 °F (65 °C)                                   | Yellow     |
| Intermediate                         | 200 °F (93 °C)                                    | 150 °F (65 °C)                                   | Green      |
| High                                 | 286 °F (141 °C)                                   | 225 °F (107 °C)                                  | Blue       |

**Sprinkler Finishes:** Brass, Chrome, and White Polyester

### Footnotes

<sup>1</sup> The sprinkler temperature rating is stamped on the deflector.

<sup>2</sup> Based on NFPA-13. Other limits may apply, depending on fire loading, sprinkler location, and other requirements of the Authority Having Jurisdiction. Refer to specific installation standards.

|   |  |   |
|---|--|---|
|  | <h2 style="margin: 0;">TECHNICAL DATA</h2> | <h3 style="margin: 0;">MICROMATIC® SPECIAL RESPONSE SPRINKLERS</h3> |
|---|--|---|

The Viking Corporation, 210 N Industrial Park Drive, Hastings MI 49058  
 Telephone: 269-945-9501 Technical Services: 877-384-5464 Fax: 269-818-1680 Email: techsvcs@vikingcorp.com

| Approval Chart  |                 |       |             |       |   |                     |                |    |                                     |   |     |      |                  |   |
|---|-----------------|-------|-------------|-------|---|---------------------|----------------|----|-------------------------------------|---|-----|------|------------------|---|
| Micromatic® Special Response Sprinklers<br>Maximum 175 PSI (12 bar) WWP   |                 |       |             |       |   |                     |                |    |                                     |   |     |      |                  |   |
| Sprinkler Base Part No. <sup>1</sup>  | Sprinkler Style | SIN   | Thread Size |       | Nominal K-Factor  |                     | Overall Length |    | Listings and Approvals <sup>3</sup> |   |     |      |                  |   |
|   |                 |       | NPT         | BSP   | U.S.  | metric <sup>2</sup> | Inches         | mm | cULus                               | FM  | VdS | LPCB | CE               |  |
| <b>Standard Orifice</b>   |                 |       |             |       |   |                     |                |    |                                     |   |     |      |                  |   |
| 09224   | Pendent         | VK134 | 1/2"        | --    | 5.6   | 80.6                | 2-3/16"        | 56 | --                                  | --  | A2X | --   | A2X <sup>4</sup> | --  |
| 09956   | Pendent         | VK134 | --          | 15 mm | 5.6   | 80.6                | 2-3/16"        | 56 | --                                  | --  | A1X | --   | --               | --  |
| 09226   | Upright         | VK138 | 1/2"        | --    | 5.6   | 80.6                | 2-3/16"        | 56 | --                                  | --  | A1  | --   | A1 <sup>5</sup>  | --  |
| 09959   | Upright         | VK138 | --          | 15 mm | 5.6   | 80.6                | 2-3/16"        | 56 | --                                  | --  | A1  | --   | --               | --  |
| 09225   | Conventional    | VK136 | 1/2"        | --    | 5.6   | 80.6                | 2-3/16"        | 56 | --                                  | --  | A1  | --   | A1 <sup>6</sup>  | --  |
| 09958   | Conventional    | VK136 | --          | 15 mm | 5.6   | 80.6                | 2-3/16"        | 56 | --                                  | --  | A1  | --   | --               | --  |
| <b>Large Orifice</b>  |                 |       |             |       |   |                     |                |    |                                     |   |     |      |                  |   |
| 09228   | Pendent         | VK212 | 3/4"        | 20 mm | 8.0   | 115.2               | 2-3/8"         | 60 | --                                  | --  | A2X | --   | A2X <sup>7</sup> | --  |
| 09227   | Upright         | VK210 | 3/4"        | 20 mm | 8.0   | 115.2               | 2-3/8"         | 60 | --                                  | --  | A1  | --   | A1 <sup>8</sup>  | --  |
| 09229   | Conventional    | VK214 | 3/4"        | 20 mm | 8.0   | 115.2               | 2-3/8"         | 60 | --                                  | --  | A1  | --   | A1 <sup>9</sup>  | --  |
| <b>Approved Temperature Ratings</b>   |                 |       |             |       | <b>Approved Finishes</b>  |                     |                |    |                                     | <b>Approved Escutcheons</b>   |     |      |                  |   |
| A - 155 °F (68 °C), 175 °F (79 °C), 200 °F (93 °C), and 286 °F (141 °C)<br>B - 155 °F (68 °C), 175 °F (79 °C), and 200 °F (93 °C)   |                 |       |             |       | 1 - Brass and Chrome<br>2 - Brass, Chrome, and White Poly-ester |                     |                |    |                                     | X - Standard surface-mounted escutcheons only<br>Y - Standard surface-mounted escutcheon, the Viking Microfast® Model F-1 Adjustable Escutcheon <sup>1</sup> , or recessed with the Viking Micromatic® Model E-1 or E-2 Recessed Escutcheon |     |      |                  |   |
| <b>Footnotes</b>  |                 |       |             |       |   |                     |                |    |                                     |   |     |      |                  |   |
| <sup>1</sup> Base part number is shown. For complete part number, refer to Viking's current price schedule.<br><sup>2</sup> Metric K-factor shown is for use when pressure is measured in bar. When pressure is measured in kPa, divide the metric K-factor shown by 10.0.<br><sup>3</sup> This chart shows the listings and approvals available at the time of printing. Check with the manufacturer for any additional approvals.<br><sup>4</sup> CE Certified, Standard EN 12259-1, EC-certificate of conformity 0786-CPD-40134 and 0786-CPD-40174.<br><sup>5</sup> CE Certified, Standard EN 12259-1, EC-certificate of conformity 0786-CPD-40135 and 0786-CPD-40175.<br><sup>6</sup> CE Certified, Standard EN 12259-1, EC-certificate of conformity 0786-CPD-40136 and 0786-CPD-40176.<br><sup>7</sup> CE Certified, Standard EN 12259-1, EC-certificate of conformity 0786-CPD-40138 and 0786-CPD-40178.<br><sup>8</sup> CE Certified, Standard EN 12259-1, EC-certificate of conformity 0786-CPD-40139 and 0786-CPD-40179.<br><sup>9</sup> CE Certified, Standard EN 12259-1, EC-certificate of conformity 0786-CPD-40140 and 0786-CPD-40180. |                 |       |             |       |   |                     |                |    |                                     |   |     |      |                  |   |
| <b>IMPORTANT: Always refer to Bulletin Form No. F_091699 - Care and Handling of Sprinklers. Viking sprinklers are to be installed in accordance with the latest edition of Viking technical data, the appropriate standards of NFPA, FM Global, LPCB, APSAD, VdS or other similar organizations, and also with the provisions of governmental codes, ordinances, and standards, whenever applicable.</b>  |                 |       |             |       |   |                     |                |    |                                     |   |     |      |                  |   |

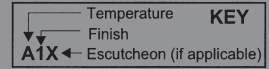



TECHNICAL DATA

MICROMATIC® SPECIAL RESPONSE SPRINKLERS

The Viking Corporation, 210 N Industrial Park Drive, Hastings MI 49058

Telephone: 269-945-9501 Technical Services: 877-384-5464 Fax: 269-818-1680 Email: techsvcs@vikingcorp.com

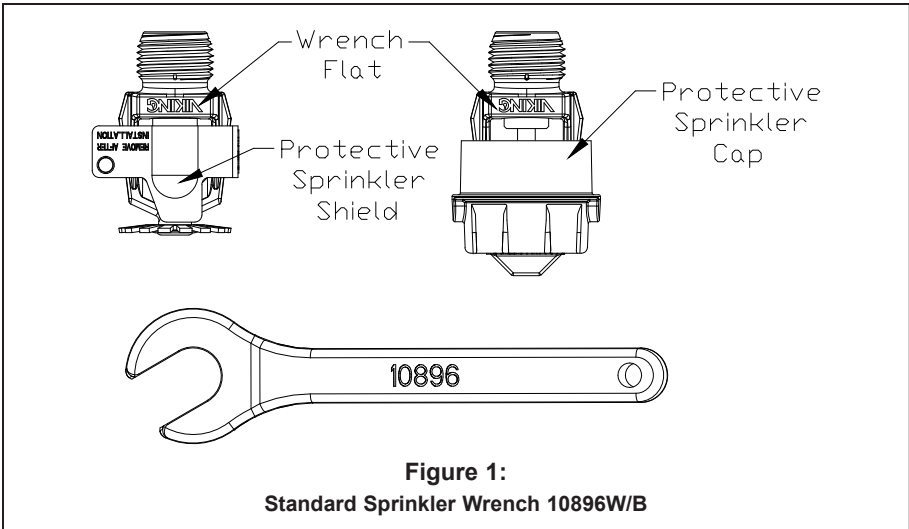

**Figure 1:**  
Standard Sprinkler Wrench 10896W/B

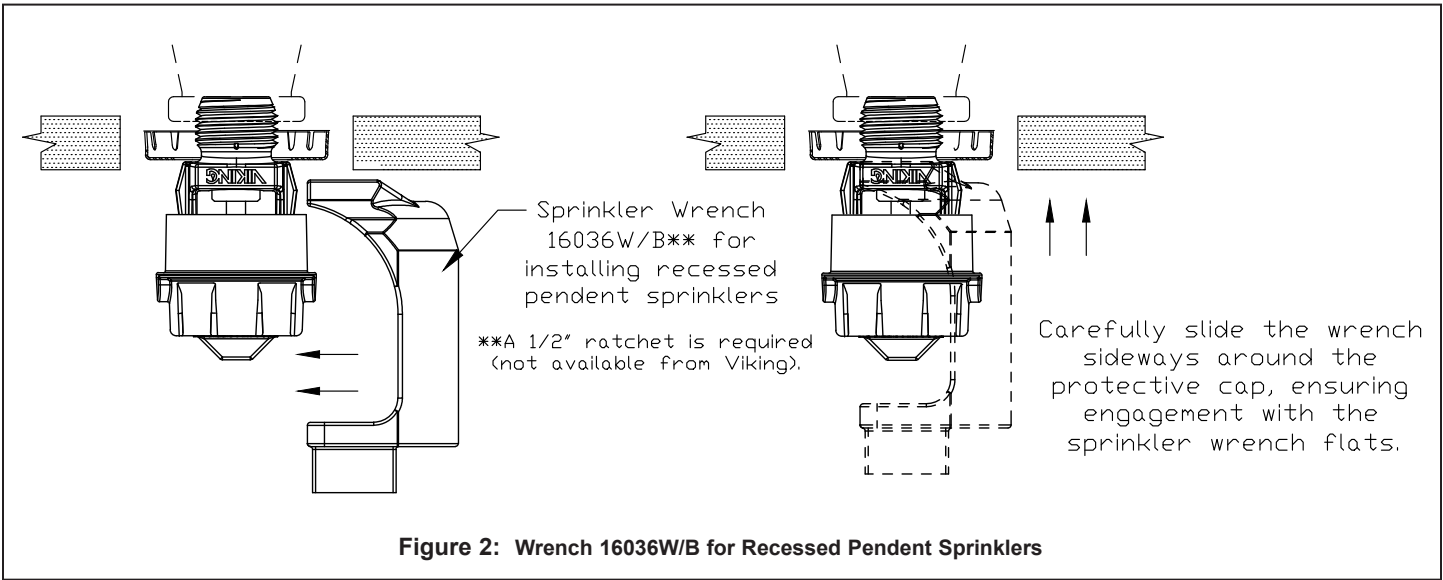

**Figure 2: Wrench 16036W/B for Recessed Pendant Sprinklers**

2. Apply a small amount of pipe-joint compound or tape to the external threads of the sprinkler only, taking care not to allow a buildup of compound in the sprinkler inlet. NOTE: Sprinklers with protective caps or bulb shields must be contained within the caps or shields before applying pipe-joint compound or tape.
  3. Install the sprinkler onto the piping using the special sprinkler wrench only, taking care not to over-tighten or damage the sprinkler operating parts. DO NOT use the deflector to start or thread the sprinkler into a fitting.
- G. After installation, the entire sprinkler system must be tested. The test must be conducted to comply with the installation standards. Make sure the sprinkler has been properly tightened. If a thread leak occurs, normally the sprinkler must be removed, new pipe-joint compound or tape applied, and then reinstalled. This is due to the fact that when the joint seal is damaged, the sealing compound or tape is washed out of the joint. Air testing the sprinkler piping prior to testing with water may be considered in areas where leakage during testing must be prevented. Refer to the installation standards and the Authority Having Jurisdiction.



## TECHNICAL DATA

## MICROMATIC® SPECIAL RESPONSE SPRINKLERS

The Viking Corporation, 210 N Industrial Park Drive, Hastings MI 49058

Telephone: 269-945-9501 Technical Services: 877-384-5464 Fax: 269-818-1680 Email: techsvcs@vikingcorp.com

H. Remove plastic protective sprinkler cap or shield **AFTER** the ceiling finish work is completed where the sprinkler is installed and there no longer is a potential for mechanical damage to sprinkler operating elements. To remove the bulb shield, simply pull the ends of the shield apart where it is snapped together. To remove cap from frame style sprinklers, turn the cap slightly and pull it off the sprinkler. **SPRINKLER CAPS OR BULB SHIELDS MUST BE REMOVED FROM SPRINKLERS BEFORE PLACING THE SYSTEM IN SERVICE!** Retain a protective cap in the spare sprinkler cabinet.

I. If it is necessary to remove the entire sprinkler unit, the system must be taken out of service. See section 6. INSPECTIONS, TESTS, AND MAINTENANCE and follow all warnings and instructions.

### 5. OPERATION

During fire conditions, the heat-sensitive liquid in the glass bulb expands, causing the glass to shatter, releasing the pip cap and sealing spring assembly. Water flowing through the sprinkler orifice strikes the sprinkler deflector, forming a uniform spray pattern to extinguish or control the fire.

### 6. INSPECTIONS, TESTS AND MAINTENANCE

**NOTICE:** The owner is responsible for maintaining the fire protection system and devices in proper operating condition. For minimum maintenance and inspection requirements, refer to the NFPA standard that describes care and maintenance of sprinkler systems. In addition, the Authority Having Jurisdiction may have additional maintenance, testing, and inspection requirements that must be followed.

A. Sprinklers must be inspected on a regular basis for corrosion, mechanical damage, obstructions, paint, etc. The frequency of the inspections may vary due to corrosive atmospheres, water supplies, and activity around the device.

B. Sprinklers that have been painted, caulked, or mechanically damaged must be replaced immediately. Sprinklers showing signs of corrosion shall be tested and/or replaced immediately as required. Installation standards require sprinklers to be tested, and if necessary, replaced after a specified term of service. Refer to the installation standards (e.g., NFPA 25) and the Authority Having Jurisdiction for the specified period of time after which testing and/or replacement is required. Sprinklers that have operated cannot be reassembled or re-used, but must be replaced. When replacing sprinklers, use only new sprinklers.

C. The sprinkler discharge pattern is critical for proper fire protection. Nothing should be hung from, attached to, or otherwise obstruct the discharge pattern. All obstructions must be immediately removed or, if necessary, additional sprinklers installed.

D. When replacing existing sprinklers, the system must be removed from service. Refer to the appropriate system description and/or valve instructions. Prior to removing the system from service, notify all Authorities Having Jurisdiction. Consideration should be given to employment of a fire patrol in the affected area.

1. Remove the system from service, drain all water, and relieve all pressure on the piping.

2. Using the special sprinkler wrench, remove the old sprinkler and install the new unit. Care must be taken to ensure that the replacement sprinkler is the proper model and style, with the correct orifice size, temperature rating, and response characteristics. A fully stocked spare sprinkler cabinet should be provided for this purpose. Follow instructions in section 4. INSTALLATION.

3. Place the system back in service and secure all valves. Check for and repair all leaks.

E. Sprinkler systems that have been subjected to a fire must be returned to service as soon as possible. The entire system must be inspected for damage and repaired or replaced as necessary. Sprinklers that have been exposed to corrosive products of combustion or high ambient temperatures, but have not operated, should be replaced. Refer to the Authority Having Jurisdiction for minimum replacement requirements.

### 7. AVAILABILITY

The Viking Micromatic® Special Response Sprinklers are available through a network of domestic and international distributors. See The Viking Corporation web site for the closest distributor or contact The Viking Corporation.

### 8. GUARANTEE

For details of warranty, refer to Viking's current list price schedule or contact Viking directly.



**TECHNICAL DATA**

**MICROMATIC® SPECIAL RESPONSE SPRINKLERS**

The Viking Corporation, 210 N Industrial Park Drive, Hastings MI 49058

Telephone: 269-945-9501 Technical Services: 877-384-5464 Fax: 269-818-1680 Email: techsvcs@vikingcorp.com

