

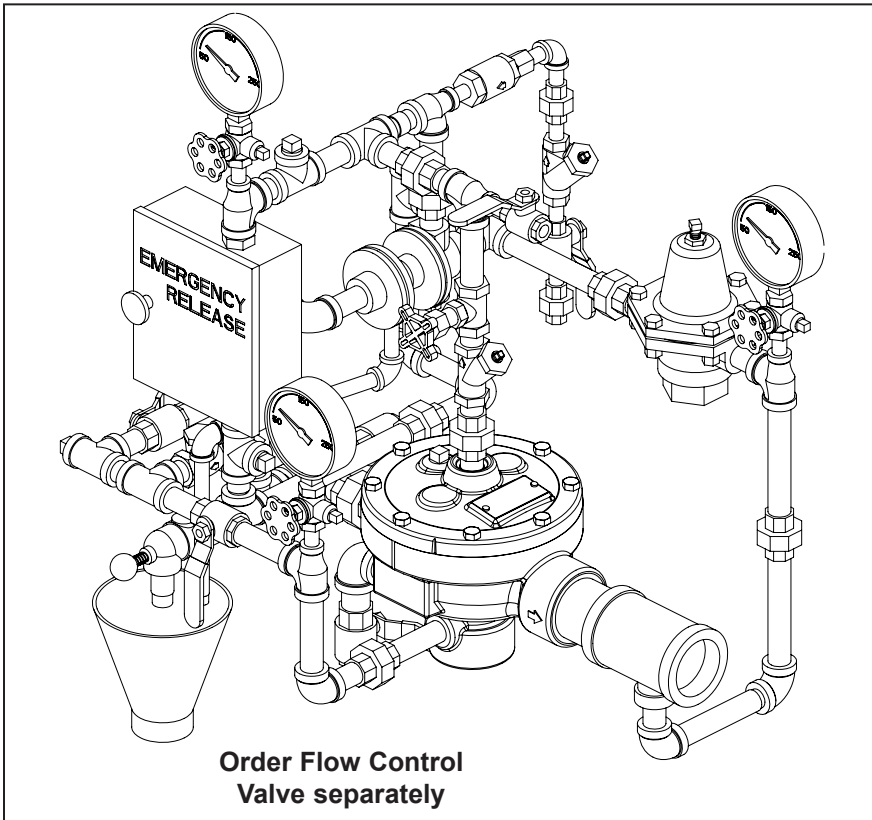

TECHNICAL DATA

PILOT REGULATING DELUGE TRIM 2" (DN50) MODEL H ANGLE STYLE FLOW CONTROL VALVE

The Viking Corporation, 210 N Industrial Park Drive, Hastings MI 49058
 Telephone: 269-945-9501 Technical Services: 877-384-5464 Fax: 269-818-1680 Email: techsvcs@vikingcorp.com
 Visit the Viking website for the latest edition of this technical data page: www.vikinggroupinc.com



This Trim Chart is for use with the Following Viking Pilot Regulating Trim Sets

Valve Size	Galvanized Trim Part No.	Brass Trim Part No.
2" (DN50)	14715-1	14715-2

This trim is for use with the following Release Module Trim Kits

Release Type	Galvanized	Brass
Electric	10830	10832
Pneumatic	10809	10811

Note: Nipple lengths for brass trim may vary from those shown on this Trim Chart.

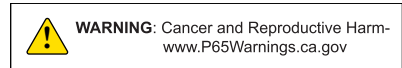

Note: When viewing this data page online, blue text represents hyperlinks and will open the appropriate data page when clicked.

Notes: For use with Trim Chart on Page 2

General Notes:

- Valve must be trimmed as shown. Any deviation from trim size or arrangement may affect the proper operation of the valve.
- Dimensions in parentheses are millimeter.
- Viking uses ANSI tee designs (large outlet on run, small outlet on run, side outlet) in all trim call-outs.

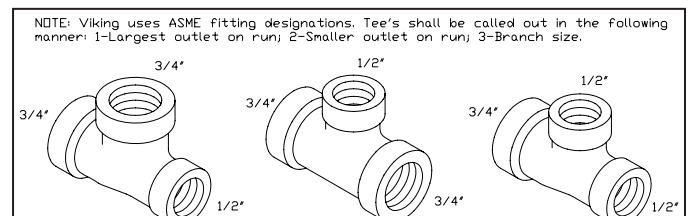

Note 1: Release System connection. Viking Flow Control Valves are compatible with hydraulic, pneumatic, and electric release systems. A pneumatic actuator is required on all Viking Flow Control Valves equipped with pneumatic release systems.

Note 2: Alarm Connections: Connect alarm line piping to 3/4" (20 mm) NPT outlet. When using a water motor alarm, a strainer is required. 1/2" (15 mm) NPT outlet is for electric alarm pressure switch.

Note 3: Optional non-interruptible connection for the alarm pressure switch to activate electric alarm panel. Note: After the flow control valve trips, this location cannot be shut off. Alarms may operate until the outlet chamber of the flow control valve is de-pressurized below the set point of the alarm pressure switch.

Note 4: The Viking Drain Check Valve is manufactured with a 0.067" (1.7 mm) orifice to allow the alarm line to drain. DO NOT substitute. Check label for proper orientation.



TECHNICAL DATA

**PILOT REGULATING
DELUGE TRIM**
2" (DN50) MODEL H
ANGLE STYLE FLOW CONTROL VALVE

The Viking Corporation, 210 N Industrial Park Drive, Hastings MI 49058
 Telephone: 269-945-9501 Technical Services: 877-384-5464 Fax: 269-818-1680 Email: techsvcs@vikingcorp.com
 Visit the Viking website for the latest edition of this technical data page: www.vikinggroupinc.com

Installation Dimensions

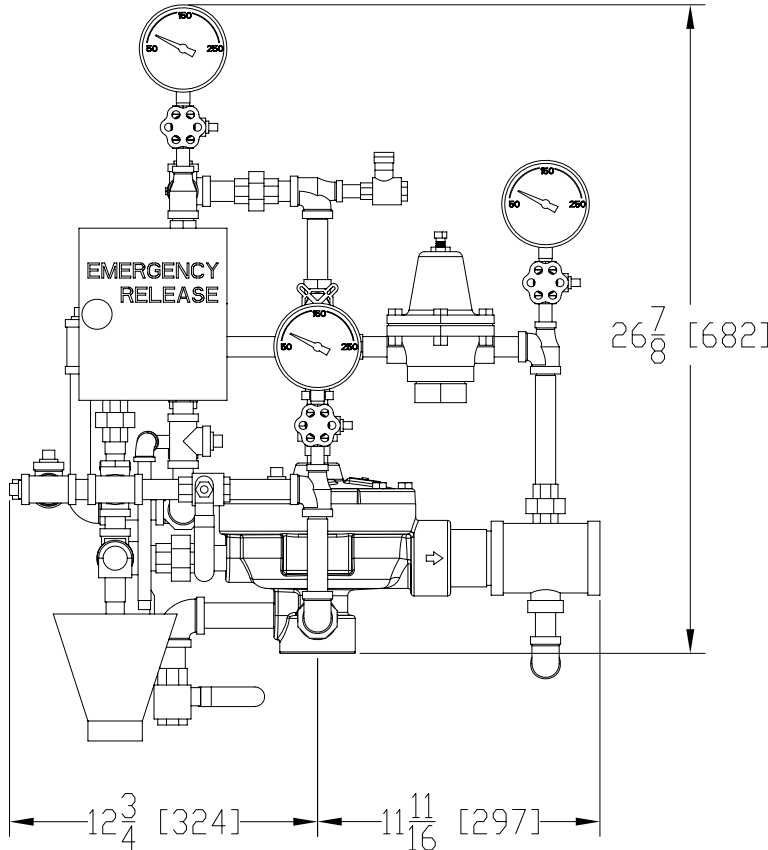

Front View

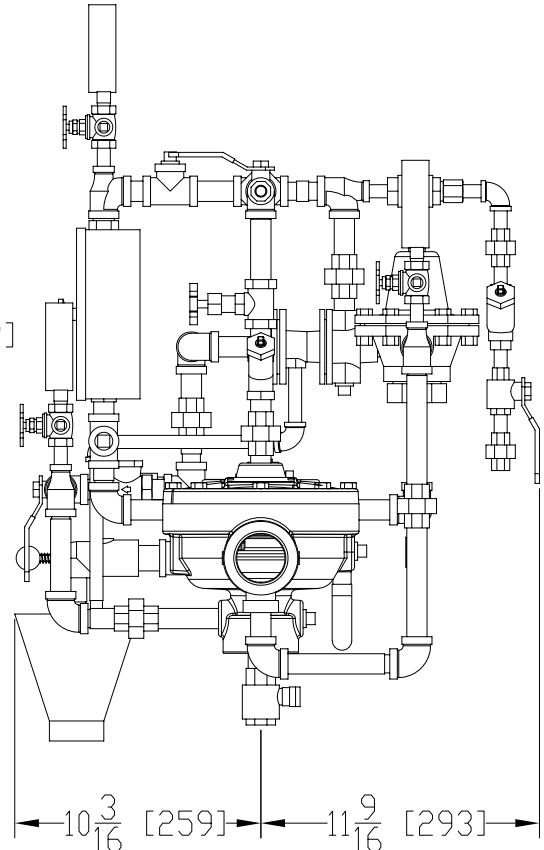

Side View