



## TECHNICAL DATA

### 36 GALLON FOAM BLADDER TANK FOAM HOSE STATION

The Viking Corporation, 210 N Industrial Park Drive, Hastings MI 49058

Telephone: 269-945-9501 Technical Services: 877-384-5464 Fax: 269-818-1680 Email: techsvcs@vikingcorp.com

Visit the Viking website for the latest edition of this technical data page [www.vikinggroupinc.com](http://www.vikinggroupinc.com)

## 1. GENERAL DESCRIPTION

The Bladder Tank Foam Hose Station is an effective and compact method of supplying a supplementary hose line as required by NFPA 409. It is particularly useful for applications where there are low or fluctuating flows and pressures that make eductor based stations problematic.

The bladder tank together with a ratio controller forms a balanced pressure proportioning system used to mix water and firefighting foam concentrate together to produce an effective extinguishing medium. The bladder tank technology is a dependable and precise mixing method that is widespread in the fixed fire protection market and requires no external power supply.

This method gives a stable water/foam ratio by adjusting automatically to the variable flow rate and pressure conditions that occur during system operation. This feature makes bladder tanks particularly suitable to low or fluctuating water inlet pressure where eductor systems are deemed unsuitable.

The bladder tank is a carbon steel pressure vessel containing an elastomeric bladder between the water and foam concentrate. The bladder permits water pressure to be transferred to the foam concentrate without the two fluids mixing together.

For further information, please contact the appropriate Viking sales office in Section 5 Availability or refer to the technical documentation. The contents of this publication are subject to modifications without notice.



*Photographs are for illustration purposes only. Refer to drawings for actual design details.*

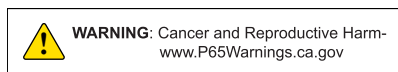

## 2. LISTINGS AND APPROVALS

The Bladder Tank Station is a pre-assembled collection of components and carries no approvals as a completed assembly. The bladder tank is FM Approved and/or UL Listed as part of a fire extinguishing system combining designated foam concentrates and ratio controllers. Pistol Grip Nozzle is FM Approved only. Approved and Listed system components can be found at [www.approvalguide.com](http://www.approvalguide.com) and [www.database.UL.com](http://www.database.UL.com)



FM Approved – Low Expansion Foam Systems (FM5130)



UL Listed – Guide GFGV & GHXV (ul162)

Manufactured according to ASME Sec. VIII Div.1.

NOTE: Other international approval certificates may be available upon request.



## TECHNICAL DATA

### 36 GALLON FOAM BLADDER TANK FOAM HOSE STATION

The Viking Corporation, 210 N Industrial Park Drive, Hastings MI 49058

Telephone: 269-945-9501 Technical Services: 877-384-5464 Fax: 269-818-1680 Email: techsvcs@vikingcorp.com

Visit the Viking website for the latest edition of this technical data page [www.vikinggroupinc.com](http://www.vikinggroupinc.com)

### 3. TECHNICAL DATA

#### 3.1 Construction Features

##### 3.1.1 Bladder Tank

- Approved design pressure of 175PSI (12.1bar)
- 100% pressure tested according to the applied design code
- Lockable corrosion resistant brass tank trim/service ball valves (UL Listed / FM Approved)
- Machine welded circumferential and longitudinal seams for maximum quality and durability
- Safety valve on water side of bladder to prevent slow overpressure and relieve thermal fluctuations
- Bladder equipped with cast rubber caps to ensure water & foam integrity under constant pressure
- Bladder specifically tested for compatibility with foams shown in FM Approval and UL Listing
- Oversized to permit concentrate thermal expansion (volume expansion allowance)
- Tank equipped with inside protection at any opening to ensure no damage to the bladder
- Internal PVC foam concentrate distribution pipe ensures optimal foam concentrate usage
- Internal water distribution channel to equalize water pressure avoiding damage to the bladder
- Internal water distribution channel to facilitate quick draining during service and maintenance
- Nameplate holder to avoid undetected corrosion on the tank's shell behind the plate
- Sight level indicator tube
- External epoxy zinc rich primer with aliphatic polyurethane finish. FM/UL for corrosive atmosphere (salt fog)

##### 3.1.2 Ratio Controller

- 2" (DN50) grooved ratio controller integrated into foam bladder tank station
- Nickel Aluminium Bronze construction for superior corrosion protection
- Operating pressure from 30PSI (2.07bar) to 145PSI (10bar)
- AFFF proportioning range from 50GPM (189 l/min) to 311 GPM (1177 l/min)
- FM Approved and/or UL Listed for use with specific Viking Foam Concentrates
- For use with Fresh or Salt Water
- Identification tag plate

##### 3.1.3 Hose Reel

- Hose reel with water supply through center of reel
- Hose 38 mm: Semi-rigid hose with 10 bar working pressure
- Hose length 30M
- NST connection
- Hose connection: Goose-neck with hose nipple
- Hand crank for rewind with gearing device
- Hose guide
- Hose reel made of galvanized steel
- Waterways made of brass
- Epoxy/polyester powder coating

##### 3.1.4 Pistol Grip Nozzle

- 1.5" NST Connection
- Selectable gallonage pistol grip nozzle (30-60-95-125 US GPM)
- Horseshoe shut off handle for straight stream or fog pattern
- Stainless steel filter mesh on nozzle inlet
- Heavy duty chrome plated shut-off ball

##### 3.1.5 Base Frame Skid

- Constructed from carbon steel profile
- Access slots for fork trucks.
- Four lifting lugs
- Coated RAL3000 Flame Red
- Complete "plug and play" solution



## TECHNICAL DATA

### 36 GALLON FOAM BLADDER TANK FOAM HOSE STATION

The Viking Corporation, 210 N Industrial Park Drive, Hastings MI 49058  
 Telephone: 269-945-9501 Technical Services: 877-384-5464 Fax: 269-818-1680 Email: techsvcs@vikingcorp.com  
 Visit the Viking website for the latest edition of this technical data page [www.vikinggroupinc.com](http://www.vikinggroupinc.com)

### 3.2 Standard Design Specifications

Table 3.2.1 - Standard Materials

Bladder tank shell and heads	ASTM A516 Gr. 70
Bladder material	Polyester reinforced hypalon-neoprene polymers
Trim valves	Brass
Safety thermal relief valve	Brass
Paint	Epoxy zinc rich primer with aliphatic polyurethane finish
Standard color	Flame Red RAL3000
Pipework	Carbon & Stainless Steel
Ratio controller	Nickel Aluminium Bronze UNS C95800 – ASTM B148
Foam orifice	UNS-C36000
Hose	Non Collapsible
Hose reel	Galvanized Steel
Hose reel internal pipework	Brass
Nozzle	Brass

### 3.3 Standard Design Specifications

Table 3.3.1 - Standard Design Specifications

Station design pressure	145PSI (10bar)
Station operating pressure range	30PSI (2.07bar) to 145PSI (10bar)
Operating temperature range	35°F to 120°F (1.7°C to 49°C)
Capacity	36 US Gallon (136 litres)
Approximate shipping weight	560 lbs (255kg)
Proportioning range (AFFF1%, 3%)	50GPM (189 l/min) to 311 GPM (1177 l/min)
Hose length	30 Metres
Hose diameter	38mm (1.5")

### 3.4 Ordering Information

Table 3.4.1 - Ordering Information

Part Number	Description
VFS0036HA	36 USG (136L) Foam Station with Hose for 1% AFFF S
VFS0036HB	36 USG (136L) Foam Station with Hose for 3% AFFF S

## 4. SCOPE OF DELIVERY

Ensure that all components are complete and in good condition.  
 The Bladder Tank Station is supplied in a shipping crate in the horizontal position.  
 All Bladder Tanks Stations have lifting slots in the base to allow safe maneuverability on site.  
 Bladder Tank is supplied empty with pre-installed bladder.  
 Small trim valves and contents level device are supplied pre-assembled to the tank as standard.  
 Safety relief valve supplied as standard according to design code selected.  
 Anchor fixing bolts are not part of our supply scope.



## TECHNICAL DATA

### 36 GALLON FOAM BLADDER TANK FOAM HOSE STATION

The Viking Corporation, 210 N Industrial Park Drive, Hastings MI 49058

Telephone: 269-945-9501 Technical Services: 877-384-5464 Fax: 269-818-1680 Email: techsvcs@vikingcorp.com

Visit the Viking website for the latest edition of this technical data page [www.vikinggroupinc.com](http://www.vikinggroupinc.com)

## 5. AVAILABILITY

Please contact your local Viking sales office for further information.

The product is available directly from Viking and official distributors only.

**EMEA: Viking SA**, ZI Haneboesch, L-4562 Differdange / Niederkorn, Tel.: +352 58 37 37 - 1, Fax: +352 38 37 36, [vikinglux@viking-emea.com](mailto:vikinglux@viking-emea.com)

**Americas: The Viking Corporation**, 210 N. Industrial Park Drive, Hastings, Michigan 49058, Toll free phone: (800) 968-9501

**APAC: The Viking Corporation (Far East) Pte. Ltd.**, 69 Tuas View Square, Westlink Techpark, Singapore 637621  
Tel: (+65) 6 278 4061, Fax: (+65) 6 278 4609, Email: [vikingsingapore@vikingcorp.com](mailto:vikingsingapore@vikingcorp.com)

## 6. PRODUCT VARIANTS

### 6.1 Options

- Available for use with Viking AFFF 1%S C6 or AFFF 3%S C6 Foam Concentrate
- Factory acceptance test, notified body or third party inspections
- Special sea freight and fumigated packaging
- Removable Hose reel protective PVC cover in Red
- Low expansion Foam branch pipe
- Galvanization of skid frame prior to painting

### 6.2 General Bladder Tank Station Layout

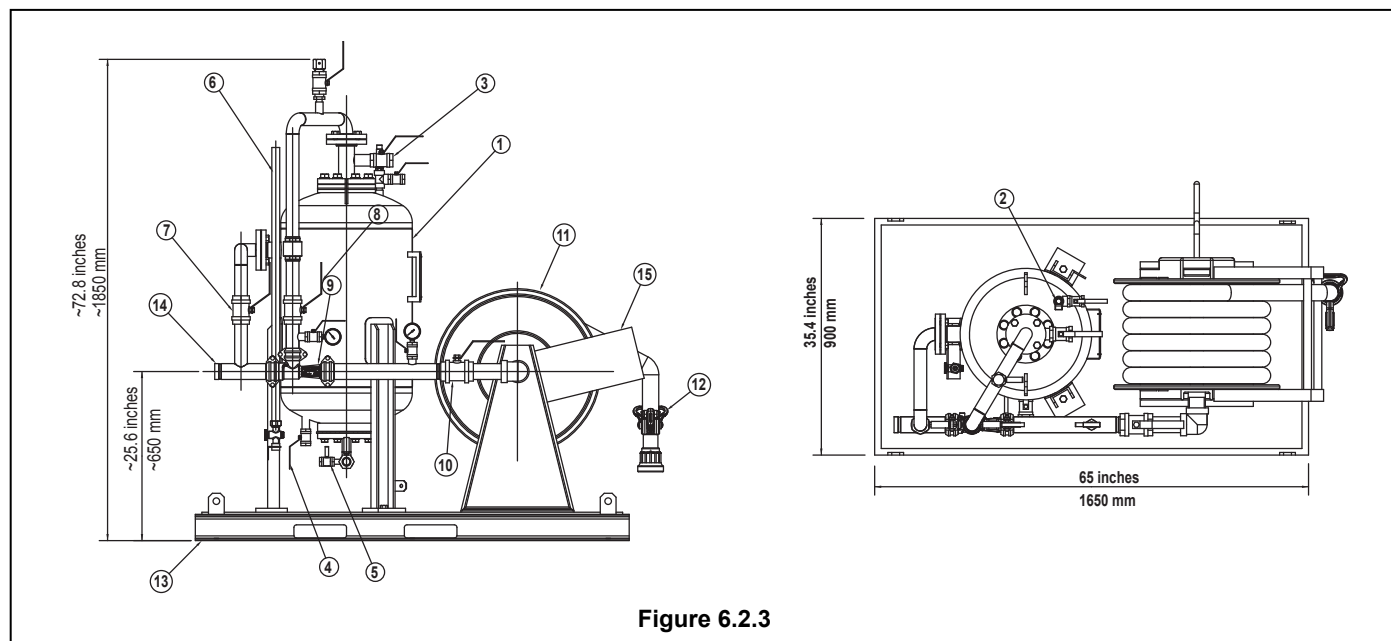

Figure 6.2.3

Table 6.2.2 - General Bladder Tank Layout and P&ID

Item	Description	Item	Description
1	Bladder tank	9	Ratio Controller
2	Bladder tank thermal relief valve	10	Hose Reel on/off valve
3	Bladder tank quick-fill inlet	11	Hose Reel
4	Bladder tank drain valve	12	Pistol Grip Nozzle
5	Bladder tank level indicator valve	13	Skid
6	Bladder tank level indicator sight tube	14	System water inlet
7	Bladder tank water shut-off valve	15	Hose guide
8	Bladder tank foam shut-off valve	--	--



# TECHNICAL DATA

## 36 GALLON FOAM BLADDER TANK FOAM HOSE STATION

The Viking Corporation, 210 N Industrial Park Drive, Hastings MI 49058

Telephone: 269-945-9501 Technical Services: 877-384-5464 Fax: 269-818-1680 Email: techsvcs@vikingcorp.com

Visit the Viking website for the latest edition of this technical data page [www.vikinggroupinc.com](http://www.vikinggroupinc.com)

## 7. PERFORMANCE DATA

### 7.1 Nozzle Operating Flows and Pressures

The Bladder Tank Station is factory set to give a flowrate of 95 US GPM (360 LPM) based on a nozzle inlet pressure of 100 PSI (7 Bar). Consideration should be given to the pressure losses coming from the pipework and hose itself.

Actual inlet pressure requirements and performance data is shown in the table below.

Nozzle Pressure		Nozzle Flow Setting		Actual Nozzle Flow		Required Station Inlet Pressure				Straight Stream Reach			
						Fully Wound		Fully Unwound		Effective		Overall	
PSI	Bar	GPM	LPM	GPM	LPM	PSI	Bar	PSI	Bar	Feet	Meters	Feet	Meters
75	5	30	115	26	98	-	-	-	-	80	24	90	27
		60	230	52	197	-	-	-	-	100	30	110	34
		95	360	82	310	109	7.5	102	7	120	36	130	39
		125	475	108	409	-	-	-	-	130	40	140	42
100	7	30	115	30	115	-	-	-	-	85	26	95	29
		60	230	60	230	-	-	-	-	105	30	115	35
		95	360	95	360	148	10.2	139	9.6	125	38	135	41
		125	475	125	475	-	-	-	-	140	42	150	45
125	8.5	30	115	34	129	-	-	-	-	90	27	100	30
		60	230	67	254	-	-	-	-	110	34	120	36
		95	360	107	401	177	12.2	168	11.6	125	38	130	41
		125	475	140	530	-	-	-	-	135	41	145	44

## 8. INSTALLATION

Refer to appropriate Installation Standards (i.e. NFPA, VdS, LPCB, etc.) and / or FM applicable FM Global Property Loss Prevention Data Sheets such as 4-12, Foam-Water Sprinkler Systems.

The Viking Installation, Operation and Maintenance Bladder Tank Manual shall also be referenced.

### NOTICE

**When designing a bladder tank station into your fire protection system, please give consideration to future maintenance activities. Ensure that adequate clearance above the bladder tank is allowed. For further guidance contact us.**

The Bladder Tank Hose Station should be fixed to the floor using the pre-drilled anchor point. The water supply should be connected to 14 "System water inlet". It is advisable to install a shut-off valve upstream of this point to facilitate isolation of the Bladder Tank Station for commissioning and future maintenance.

## 9. OPERATION

### 9.1 Overview

1. The bladder tank stores foam concentrate inside the bladder. When used in conjunction with the Viking Ratio Controller it proportions the foam concentrate accurately into the water stream.
2. During system activation, the outer side of the bladder tank is pressurized by the system water supply which forces foam concentrate into the ratio controller.
3. Simultaneously, as water flows through the venturi area of the ratio controller, a metered pressure drop also draws foam concentrate into the system water creating a foam solution mixed to the appropriate ratio.
4. The foam solution flows through the hose reel system and out of the open nozzle (or optional branch pipe).
5. As the foam concentrate continues to flow from the inside of the bladder, system water enters the bladder tank on the outside of the bladder keeping a balanced pressure system.
6. If water discharge only is required, the pre-installed foam shut-off valve (8) should be closed.



## TECHNICAL DATA

### 36 GALLON FOAM BLADDER TANK FOAM HOSE STATION

The Viking Corporation, 210 N Industrial Park Drive, Hastings MI 49058

Telephone: 269-945-9501 Technical Services: 877-384-5464 Fax: 269-818-1680 Email: techsvcs@vikingcorp.com

Visit the Viking website for the latest edition of this technical data page [www.vikinggroupinc.com](http://www.vikinggroupinc.com)

#### 9.2 Bladder Tank

Refer to Bladder Tank Manual for Filling and Operational requirements.

#### NOTICE

All installation, commissioning, operation and maintenance activities must be carried out by personnel who are qualified and authorized by the system's owner or manager. The personnel responsible for these activities must proceed only after reading and fully understanding the Bladder Tank Manual for Filling and Operational requirements.

As the bladder tanks manufactured by Viking have been designed, tested and approved by third party organizations including the durability and performance of the original accessories installed - only original spare parts and consumables must be used when replacements are required. The use of non-original spare parts may result in an unsafe or poor performance of the bladder tank and decrease its overall lifetime usage. Use of non-original spare parts automatically expires the warranty clause of the supplied equipment. This prescription applies, in particular, to the separation bladder between water and foam concentrate and to the foam concentrate itself.

#### 9.3 Ratio Controller

The Ratio Controller is supplied pre-assembled on the Bladder Tank Station skid respecting the installation requirements given in data page F\_031416 | TD1.3.2.1.

#### 9.4 Hose Reel

#### NOTICE

Rubber is a natural compound and will wear down over time based on a natural degradation rate if the product is installed in specific installation conditions and locations. The natural degradation rate is increased significantly in conditions such as direct sunlight and Ozone polluted areas. We strongly recommend installing the hose reel in a location where it is not exposed to direct Sunlight/Ultraviolet Radiation and where there is no Ozone present.

The hose reel is unwound by securely gripping and pulling the end of hose to the desired area of operation. Care should be taken to ensure that the hose is correctly threaded through the hose guide. After use, the hose reel on/off valve (10) should be closed and pressure should be relieved from the hose reel by opening the nozzle (12). The hose can then be re-wound using the hand crank provided.

#### 9.5 Pistol Grip Nozzle

#### ⚠ WARNING

- An inadequate supply of nozzle pressure and/or flow will cause an ineffective stream and can result in injury, death or loss of property.
- Failure to restrain nozzle reaction can cause firefighter injury from loss of footing and/or stream protection. Nozzle reaction will vary as supply conditions change: such as opening or closing other nozzles, hose line kinks, changes in pump settings, etc. Changes in spray pattern or flushing will also affect nozzle reaction. The nozzle operator must always be positioned to restrain the nozzle reaction in the event of those changes.
- Injury from whipping can occur. If nozzle gets out of control or away from operator, retreat from nozzle immediately. Do not attempt to regain control of nozzle while flowing water.
- Fire streams are capable of injury and damage. Do not direct water stream to cause injury or damage to persons or property.
- There are a wide variety of foam concentrates. Each user is responsible for verifying that any foam concentrate chosen to be used with this unit has been tested to assure that the foam obtained is suitable for the purpose intended.

1. Open and close the shutoff slowly at all times.
2. To open the nozzle pull the "D" handle towards the inlet.
3. To close the nozzle push the "D" handle towards the outlet.
4. Do not keep the shutoff handle in half-way position, as when the ball valve is partially open, it will cause turbulence and adversely affects stream quality.
5. To change the spray pattern: rotate the bumper clockwise (right) for a straight stream and counter clockwise (left) for a wide homogenous fog pattern.
6. Rotate the flow selection ring to adjust flow setting to the desired flow. The nozzle will flow the rated amount when the pressure at the nozzle is 100 PSI (7 bar).
7. To remove trapped debris in the nozzle, rotate the flow selection ring to the FLUSH position to open up the nozzle, allowing debris to pass through.
8. Large amounts or pieces of debris may be unflushable and can cause reduced flow and compromise nozzle performance. In the event of a blockage, retreat to a safe area and uncouple the nozzle to remove debris.



## TECHNICAL DATA

### 36 GALLON FOAM BLADDER TANK FOAM HOSE STATION

The Viking Corporation, 210 N Industrial Park Drive, Hastings MI 49058

Telephone: 269-945-9501 Technical Services: 877-384-5464 Fax: 269-818-1680 Email: techsvcs@vikingcorp.com

Visit the Viking website for the latest edition of this technical data page [www.vikinggroupinc.com](http://www.vikinggroupinc.com)

## 10. GUARANTEE

For details of warranty, refer to Viking's current list price schedule or contact Viking directly.

## 11. INSPECTIONS, TESTS, AND MAINTENANCE

### NOTICE

The owner is responsible for maintaining the fire protection system and devices in proper operating condition.

### ⚠ WARNING

Any system maintenance that involves placing a control valve or detection system out of service may eliminate the fire protection capabilities of that system. Prior to proceeding, notify all Authorities Having Jurisdiction. Consideration should be given to employment of a fire patrol in the affected areas.

Refer to respective requirements, according to the relevant standards for Inspection, Testing and Maintenance such as NFPA 11 and NFPA 14. In addition, the "Authority Having Jurisdiction" (AHJ) may have additional maintenance, testing and inspection requirements that must be followed.

### 11.1 Bladder Tank

Refer to the Bladder Tank Manual for Maintenance Requirements.

### 11.2 Ratio Controller - Not applicable

### 11.3 Hose Reel

In addition to the relevant Standard requirements for the Maintenance of hose reels with semi-rigid hose and systems with lay-flat hose it is recommended to follow this procedure:

The firewater hose reel is part of the safety equipment. As such, it will not be in continuous use. This means that the performance and condition of the hose reel will not continuously reveal itself. Furthermore, long periods of inactivity of the system will tend to increase the risk of getting parts of the system clogged or stuck. Therefore, regular maintenance is vital in order to ensure that the firewater hose reel works safely when needed in case of fire.

We recommend a schedule of maintenance intervals as follows:

#### Monthly

- Isolation valve - The isolation valve (10) should be inspected every month to verify that the valve handle is operating freely, and that no leakage has occurred. Check that all isolation valves are in the right position (normally closed).
- Hose reel - Check that hose reel turns easily without leakage in connection & swiveling parts.

#### Every three months

Execute the monthly maintenance, in addition to the following:

- Isolation valve - The isolating inlet valve should be inspected to verify that ball is operating freely, and that valve body and handle is undamaged and that no leakages have occurred.
- Hose reel bearing - These parts shall be greased through the grease nipple. Black Molly or equivalent grease shall be used.

### 11.4 Pistol Grip Nozzle

1. Nozzles should be inspected before and after each use to ensure all parts are in a satisfactory working condition.
2. If any one of the following problems are encountered while in use the nozzle should be withdrawn from service and repaired:
  - (A) Controls that are inoperable or difficult to operate
  - (B) Excessive wear
  - (C) Water leakage from joints
  - (D) Broken spinning teeth
  - (E) Loose or missing screws
3. Periodically flushing the nozzle with clean water and remove any build up of dirt from the exterior of the nozzle.





## TECHNICAL DATA

### 36 GALLON FOAM BLADDER TANK FOAM HOSE STATION

The Viking Corporation, 210 N Industrial Park Drive, Hastings MI 49058

Telephone: 269-945-9501 Technical Services: 877-384-5464 Fax: 269-818-1680 Email: techsvcs@vikingcorp.com

Visit the Viking website for the latest edition of this technical data page [www.vikinggroupinc.com](http://www.vikinggroupinc.com)

4. Factory lubrication applied to the nozzle during production is sufficient and the lubricant used has excellent washout resistance and long term performance. Regularly check the moving parts of the nozzle for smooth and free operation, and signs of damage. If the nozzle is operating correctly, then no additional lubrication is required. Any nozzle that is not operating correctly should be immediately removed from service.
5. Regularly check any external screws for tightness, tighten as required with the addition of a good quality thread locker (i.e. Loctite262).

## 12. DISPOSAL



At end of use the product described here should be disposed of via the national recycling system. Upon request, the manufacturer can take back and properly dispose any electrical equipment and electronic devices, if applicable.

## 13. ACCESSORIES AND SPARE PARTS

**Table 12.1.1 - Optional / Standard Spare Parts**

Part Number	Description	Material	Connection
B10C12.1	Standard Safety Valve	Brass	1/2"
HYDROMETER	Hydrometer Level Gauge	Stainless Steel 316	1/2"
FILLDEVICE	Filling Device with KPA Gauge	Carbon Steel	1"
Contact us.	Replacement Bladder	Hypalon-Neoprene	Contact us.

**Table 12.2.1 - Bladder Tank Manual**

Part Number	Description	Part Number	Description
F032216-EN	English	F032216-NL	Dutch
F032216-DE	German	F032216-PL	Polish
F032216-ES	Spanish	F032216-SV	Swedish
F032216-FR	French	F032216-TR	Turkish
F032216-IT	Italian	--	-

## 14. DECLARATION OF CONFORMITY

If required

Contact the appropriate sales office in **Section 5 Availability** for further assistance.