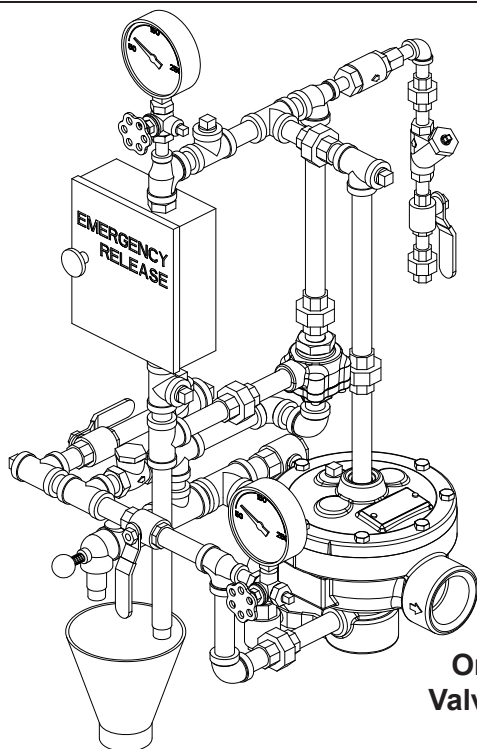

VIKING[®]**TECHNICAL DATA****2" (DN50)****MODEL E DELUGE VALVE
CONVENTIONAL TRIM CHART**

Maximum 250 PSI Water Working Pressure

The Viking Corporation, 210 N Industrial Park Drive, Hastings MI 49058

Telephone: 269-945-9501 Technical Services: 877-384-5464 Fax: 269-818-1680 Email: techsvcs@vikingcorp.com

Figure 1**Order Deluge
Valve Separately**

WARNING: Cancer and Reproductive Harm-
www.P65Warnings.ca.gov

This Trim Chart is for use with
the following Viking Trim Sets

Valve Size	Galvanized Trim Part No.	Brass Trim Part No.
2" (DN50)	14630-1	14630-2

This Trim is for use with the following
Release Module Trim Kits

Release Type	Galvanized*	Brass**
Electric	10830	10832
Pneumatic	10809	10811
Electric/ Pneumatic	12661-1	12661-2
Pneumatic/ Pneumatic	12662-1	12662-2

* Standard Trim sets for Model E Deluge Valves consist of galvanized nipples and fittings.

**Refer to Technical Data describing the Halar[®] Coated Deluge Valve and the *Viking Foam System Engineering Design Data* book for applications where brass trim is recommended.

Note: Nipple lengths for brass trim may vary from those shown on this Trim Chart.

Notes: For use with Trim Chart on Page 226b

Note: When viewing this data page online, blue text represents hyperlinks and will open the appropriate data page when clicked.

General Notes:

- Valve must be trimmed as shown. Any deviation from trim size or arrangement may affect the proper operation of the valve.
- All pipe, 3/4" (20 mm) and smaller, shall be galvanized steel except when other materials are specified in the Technical Data for the Halar[®] Coated Deluge Valve or when other materials are specified in the *Viking Foam System Engineering and Design Data* book.
- When Model E Deluge Valves are used on pre-mixed Foam Systems, trim piping must be of black steel pipe with cast iron or malleable iron fittings unless otherwise specified in the Technical Data for the Halar[®] Coated Deluge Valve or the *Viking Foam System Engineering and Design Data* book.
- Dimensions in parentheses are millimeter and may be approximations.

Note 1: 1/2" (15 mm) NPT plugged outlet provided for connecting certain optional components and associated trim.

Note 2: Release System connection. Viking Deluge and Flow Control Valves are compatible with hydraulic, pneumatic, and electric release systems. A Pneumatic Actuator is required on all Viking Deluge Valves and Flow Control Valves equipped with Pneumatic Release Systems.

Note 3: Alarm Connections: Connect alarm line piping to 3/4" (20 mm) NPT outlet. When using a Water Motor Alarm, a strainer is required. 1/2" (15 mm) NPT outlet is for electric Alarm Pressure Switch.

Note 4: Optional non-interruptible connection for Alarm Pressure Switch to activate electric alarm panel. Note: After the Deluge Valve trips, this location cannot be shut off. Alarms may operate until the outlet chamber of the deluge valve is de-pressurized below the set point of the Alarm Pressure Switch.

Note 5: Viking Drain Check Valve is manufactured with a 0.067" (1.7 mm) orifice to allow alarm line to drain. DO NOT substitute. Check label for proper orientation.

Note 6: Inlet side of PORV is connected to the top chamber of the deluge valve. Inlet of PORV should be facing up. Outlet goes to open drain.



TECHNICAL DATA

2" (DN50)
MODEL E DELUGE VALVE
CONVENTIONAL TRIM CHART
 Maximum 250 PSI Water Working Pressure

The Viking Corporation, 210 N Industrial Park Drive, Hastings MI 49058
 Telephone: 269-945-9501 Technical Services: 877-384-5464 Fax: 269-818-1680 Email: techsvcs@vikingcorp.com

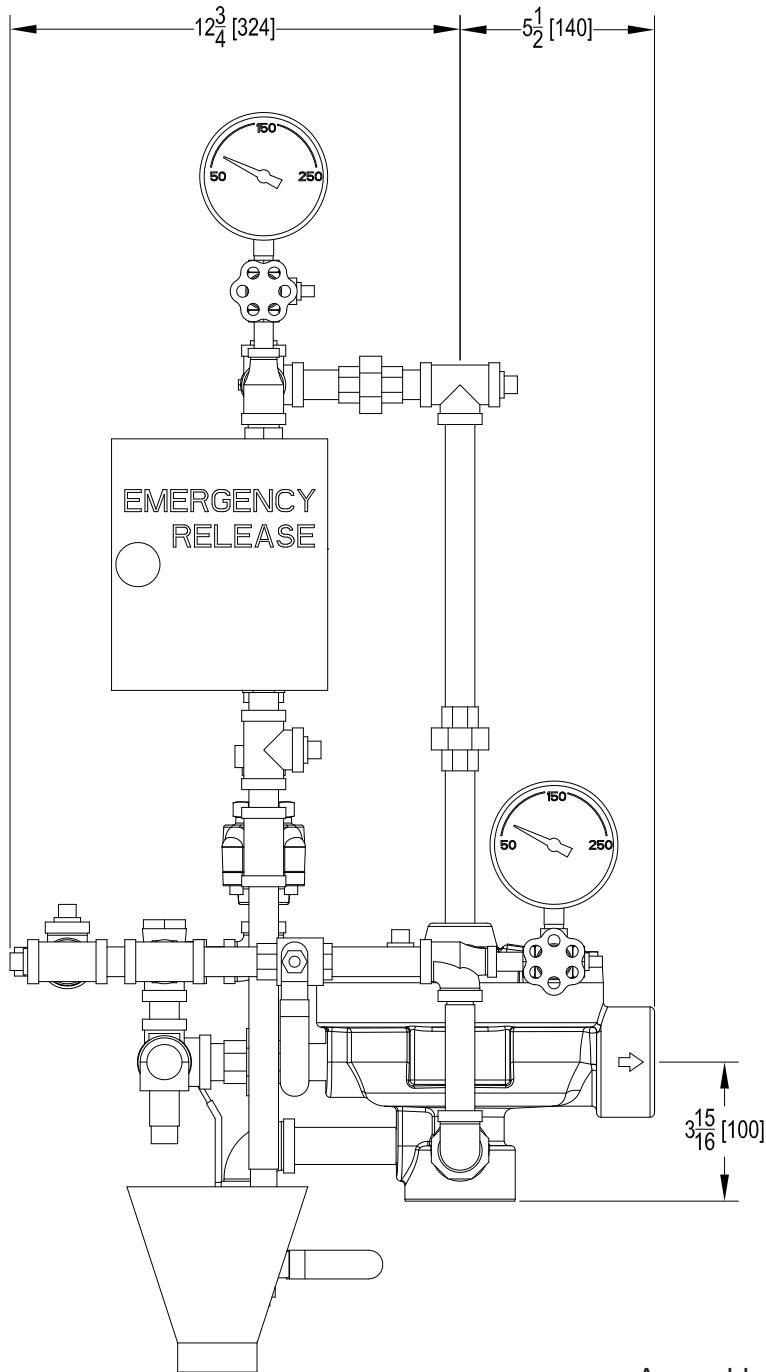

Assembled trim dimensions are approximations with a tolerance of $\pm 1/4"$

Figure 3a: Installation Dimensions



TECHNICAL DATA

2" (DN50)
MODEL E DELUGE VALVE
CONVENTIONAL TRIM CHART
 Maximum 250 PSI Water Working Pressure

The Viking Corporation, 210 N Industrial Park Drive, Hastings MI 49058

Telephone: 269-945-9501 Technical Services: 877-384-5464 Fax: 269-818-1680 Email: techsvcs@vikingcorp.com

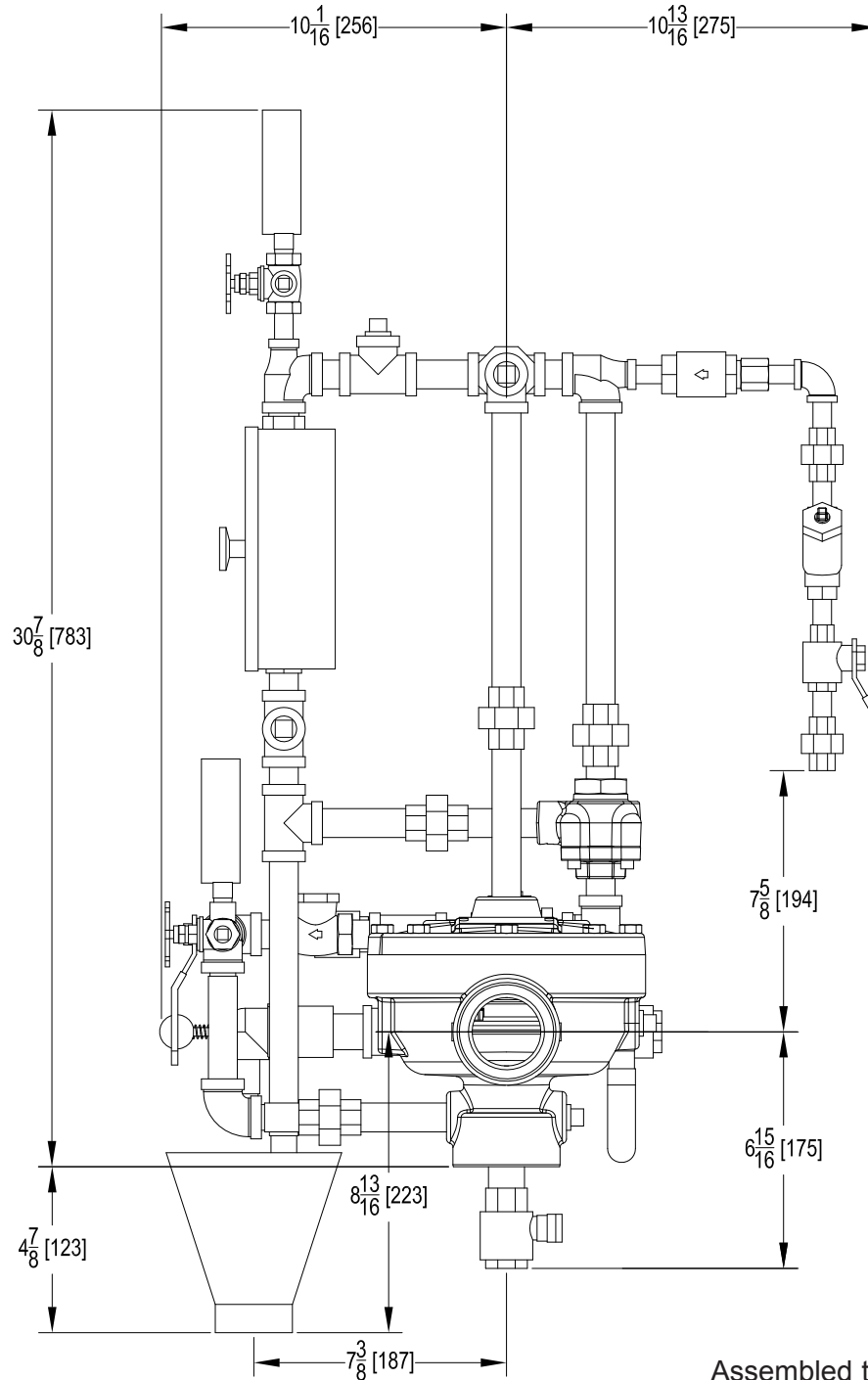

Assembled trim dimensions are approximations with a tolerance of $\pm 1/4$ "

Figure 3b: Installation Dimensions