



# TECHNICAL DATA

## DELUGE VALVE MODEL VXD

The Viking Corporation, 210 N Industrial Park Drive, Hastings MI 49058  
 Telephone: 269-945-9501 Technical Services: 877-384-5464 Fax: 269-818-1680 Email: techsvcs@vikingcorp.com  
 Visit the Viking website for the latest edition of this technical data page [www.vikinggroupinc.com](http://www.vikinggroupinc.com)

### 1 DESCRIPTION

The Viking Model VXD Deluge Valve is a flood valve with one moving mechanism. The Deluge Valve is used to control water flow in Deluge and Preaction sprinkler systems. The valve is held closed by system water pressure trapped in the priming chamber, keeping the outlet chamber and system piping dry. In fire conditions, when the releasing system operates, pressure is released from the priming chamber. The Deluge Valve diaphragm opens to allow water to flow into the system piping.

#### Features

1. Field replaceable diaphragm
2. Designed for installation in horizontal or vertical position
3. Automatically resets without opening the valve
4. Compatible with Hydraulic, Pneumatic and Electric Release Systems



### 2 LISTINGS AND APPROVALS:

**cULus Listed:** Guide No. VLFT and VLFT7

**FM Approved:** Deluge Sprinkler Systems, Preaction Sprinkler Systems, Refrigerated Area Sprinkler Systems

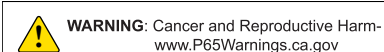

### 3 TECHNICAL DATA

#### Specifications:

Pressure Rating: 250 psi (17.2 bar)

Installation Position: Vertical or Horizontal

Operating Temperature Range: 39 to 140 °F (4 to 60 °C)

Priming chamber supply restriction (required): 1/8" (3 mm)

**Material Standards:** Refer to Figure 3

**Table 1: Ordering Information and Technical Data for Model VXD Valves**

Nominal Size	Part Number			Friction Loss <sup>1</sup>	C <sub>v</sub> Factor	Shipping Weight			
	Groove/ Groove	Flange/Flange (ANSI 150)	Flange/Flange (PN16)			Grooved		Flanged	
						Lbs.	kg	Lbs.	kg
1-½	23310	Not Available	Not Available	11	53	7	3.1	--	--
2	23311	Not Available	Not Available	21	74	10	4.5	--	--
2½	23312	Not Available	Not Available	14	142	22	10	--	--
3	23313	23314	23315	24	189	28	13	47	21
4	23316	23317	23318	56	255	60	27	81	37
6	23319	23320	23321	52	754	97	44	128	58
8	23322	23323	23324	86	1232	167	76	207	94
10	23325	23326	23327	107	1991	396	180	470	214

1. Expressed in equivalent length of pipe based on Hazen & Williams Formula. C-120.

#### Trim and Accessories

Trim Packages are available for the Model VXD Deluge Valve in several configurations (Refer to the applicable document for the desired system type for more information). The configurations are available pre-trimmed or loose. Additional accessories are available and may be required for system operation or supervision. Refer to the system description and technical data for complete operating trim requirements for the desired system.



# TECHNICAL DATA

## DELUGE VALVE MODEL VXD

The Viking Corporation, 210 N Industrial Park Drive, Hastings MI 49058  
 Telephone: 269-945-9501 Technical Services: 877-384-5464 Fax: 269-818-1680 Email: techsvcs@vikingcorp.com  
 Visit the Viking website for the latest edition of this technical data page [www.vikinggroupinc.com](http://www.vikinggroupinc.com)

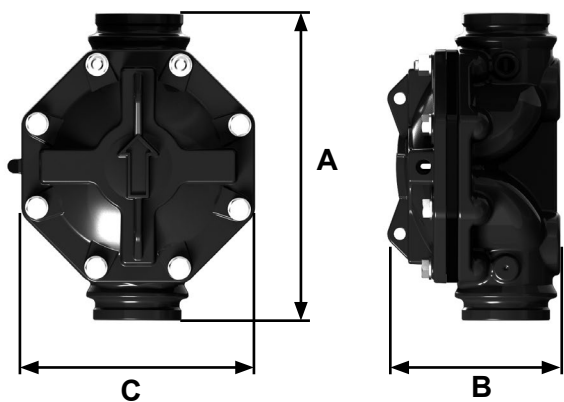

Figure 1: Dimensions - Groove/Groove

Table 2: Model VXD Groove/Groove Valve Dimensions

Size In (DN)	A In (mm)	B In (mm)	C In (mm)	Weight Lbs. (Kg)
1½"	8	3-¾	5	6-¾
(DN 40)	(205)	(97)	(127)	(2.9)
2"	8-¾	4-¾	5-½	9-¾
(DN 50)	(220)	(112)	(140)	(4.5)
2-½"	12	4-¾	8	22
(DN 65)	(305)	(122)	(204)	(10)
3"	12-¾	6-¼	9	29-¼
(DN 80)	(327)	(158)	(230)	(13.3)
4"	15-¾	8-¼	11-¾	59-½
(DN 100)	(400)	(212)	(302)	(27)
6"	18-¼	11-¾	13-¾	93¾
(DN 150)	(464)	(300)	(354)	(42.3)
8"	22-¾	14-¼	18-¼	166-¼
(DN 200)	(570)	(364)	(466)	(75.4)
10"	30-¼	25-½	24.2	482
(DN 250)	(768)	(638)	(616)	(218.6)

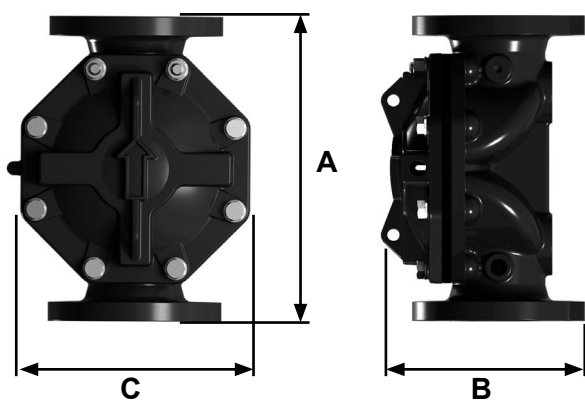

Figure 2: Dimensions - Flange/Flange

Table 3: Model VXD Flange/Flange Valve Dimensions

Size In (DN)	A In (mm)	B In (mm)	C In (mm)	Weight Lbs. (Kg)
3"	12-¾	7-¾	9	47
(DN 80)	(327)	(200)	(230)	(21.3)
4"	15-¾	8-¾	11.9	84
(DN 100)	(400)	(227)	(302)	(38)
6"	18-¼	14-¾	13.9	127¾
(DN 150)	(464)	(365)	(354)	(56.6)
8"	22-¾	16.4	18.3	211-⅝
(DN 200)	(570)	(416)	(466)	(96)
10"	30-¼	25-½	24.2	482
(DN 250)	(768)	(638)	(616)	(218.6)



# TECHNICAL DATA

## DELUGE VALVE MODEL VXD

The Viking Corporation, 210 N Industrial Park Drive, Hastings MI 49058  
 Telephone: 269-945-9501 Technical Services: 877-384-5464 Fax: 269-818-1680 Email: techsvcs@vikingcorp.com  
 Visit the Viking website for the latest edition of this technical data page www.vikinggroupinc.com

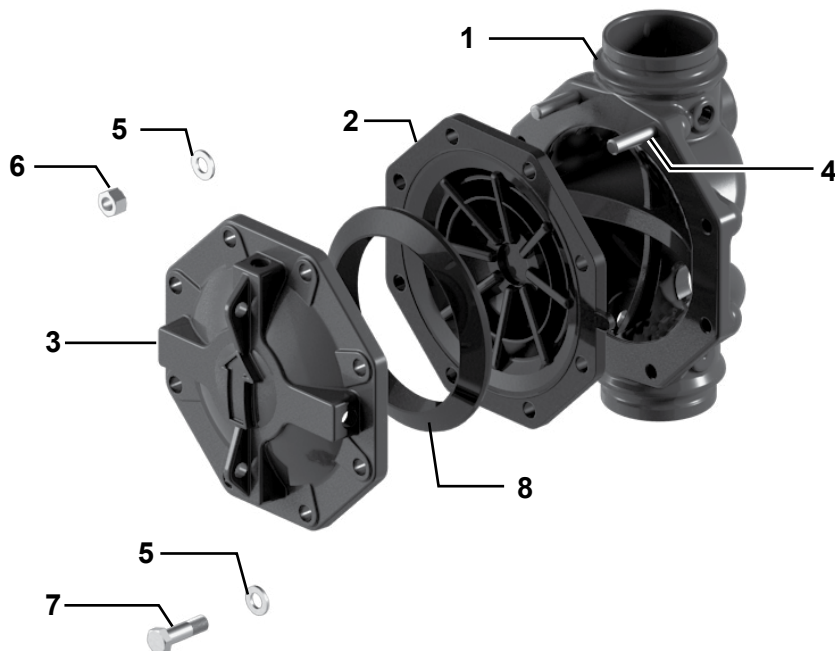

Figure 3: Components (4" Valve Shown)

Table 4: Components and Materials

Item	Description	Material	Quantity							
			1-1/2"	2"	2-1/2"	3"	4"	6"	8"	10"
1	Body	Ductile iron with epoxy polyester coating	1	1	1	1	1	1	1	1
2	Diaphragm	Nitrile butadiene rubber (NBR)	1	1	1	1	1	1	1	1
		Replacement diaphragm kit part number	23780	23781	23782	23783	23784*	23785*	23786*	23787*
3	Cover	Ductile iron with epoxy polyester coating	1	1	1	1	1	1	1	1
4	Stud	Zinc plated steel	Not used				2	2	2	2
5	Washer	Zinc plated steel	4	4	4	4	8	8	8	16
6	Nut	Zinc plated steel	Not used				2	2	2	2
7	Bolt	Zinc plated steel	4	4	4	4	6	6	6	14
8	V-Ring	Nitrile butadiene rubber (NBR)	Not used				1	1	1	Not used

\* Kit includes V-ring

Table 5: Fastener Specifications

Item	Description	Valve Size							
		1-1/2"	2"	2-1/2"	3"	4"	6"	8"	10"
4	Stud	Not used				M16 x 75	M16 x 85	M20 x 110	M24 x 130
7	Bolt	M12 x 35	M12 x 40	M16 x 50	M16 x 55	M16 x 50	M16 x 55	M20 x 70	M24 x 80
Torque value ft-lb (Nm)		18.4 (25)	22.1 (30)	36.9 (50)	53.8 (73)	64.9 (88)	71.5 (97)	87.0 (118)	118.0 (160)



## TECHNICAL DATA

### DELUGE VALVE MODEL VXD

The Viking Corporation, 210 N Industrial Park Drive, Hastings MI 49058

Telephone: 269-945-9501 Technical Services: 877-384-5464 Fax: 269-818-1680 Email: techsvcs@vikingcorp.com

Visit the Viking website for the latest edition of this technical data page [www.vikinggroupinc.com](http://www.vikinggroupinc.com)

## 4 INSTALLATION

### General Information

1. Viking Deluge Valves may be installed in the horizontal or vertical position.
2. The valve must be installed in an area not subject to freezing temperatures or physical damage.
3. The valve must be trimmed according to current Viking Trim Charts and appropriate instructions for the system used. Trim Charts are available on the Viking website, and are provided with trim packages.
4. Remove all plastic protectors from the openings of the Deluge Valve.
5. Apply a small amount of pipe joint compound or tape to the external threads of all pipe connections required. Take care not to allow any compound, tape, or other foreign matter inside any of the nipples or openings of the valve or trim components.
6. Verify that all system components are rated for the water working pressure of the system.
7. Hydrostatic Test:

The Model VXD Deluge Valve is manufactured and listed for use at a maximum Water Working Pressure of 250 PSI (17.2 bar). The valve is factory tested at 500 PSI (34.5 bar). The valves may be hydrostatically tested at 300 PSI (20.7 bar) and/or 50 PSI (3.5 bar) above the normal Water Working Pressure, for limited periods of time (two hours), for the purpose of acceptance by the Authority Having Jurisdiction.

**TRIM NOTE: DISCHARGE PIPING FROM THE FLOW TEST VALVE AND ALL SYSTEM DRAINS SHOULD BE KEPT SEPARATE.**

8. The priming line must be connected upstream of the system water supply main control valve or to a constant source of water at a pressure equal to the system water supply.
9. After the Deluge Valve is set, operation of the Deluge Valve requires the release of priming water from the priming chamber. This may be by automatic or manual operation of the release system. Model VXD Deluge Valves are compatible with hydraulic, pneumatic and electric release systems.
  - a. Hydraulic Release Systems: See Figures 12-16 for the maximum allowable elevation of hydraulic release piping above the Deluge Valve. If the maximum height of hydraulic release piping exceeds the limit shown in Figures 12-16 for the valve used, use a Pneumatic or Electric Release System
  - b. Pneumatic Release Systems: A Viking Pneumatic Actuator is required between the release system connection provided on deluge valve trim and pneumatic release Piping.
  - c. Electric Release: Solenoid Valves, System Control Panels, and Electrical Detectors must be compatible. Consult appropriate listing and/or approval guides.

### **CAUTION**

**Operation of Viking Deluge Valves by pressurizing the priming chamber with air pressure or any other pressurized gas is not recommended or approved.**

## 5 OPERATION

The Viking Model VXD Deluge Valve has an inlet chamber, an outlet chamber and a priming chamber. The inlet chamber and outlet chamber are separated from the priming chamber by the diaphragm.

### In the set condition:

System pressure is supplied to the priming chamber through a restricted priming line (trim) equipped with a check valve. System water supply pressure trapped in the priming chamber holds the diaphragm in the closed position due to area differential design. The Diaphragm separates the inlet chamber from the outlet chamber, keeping the outlet chamber and system piping dry.

### In fire conditions:

When the release system operates, pressure is released from the priming chamber faster than it is supplied through the restricted priming line. Water supply pressure in the inlet chamber forces the diaphragm to open allowing water to flow through the outlet and into the system and alarm devices.

The inlet side of the PORV is connected directly to the top chamber of the deluge valve. In the set position, pressure is supplied to the inlet. The pressure on the push rod prevents water from escaping. When the deluge valve operates, water is drained from the PORV inlet. When the 10:1 differential is overcome, the push rod opens, allowing the prime water to drain. If a release resets, priming water will continue to escape through the PORV, allowing the deluge valve to continue to operate until the system is reset.



## TECHNICAL DATA

DELUGE VALVE  
MODEL VXD

The Viking Corporation, 210 N Industrial Park Drive, Hastings MI 49058

Telephone: 269-945-9501 Technical Services: 877-384-5464 Fax: 269-818-1680 Email: techsvcs@vikingcorp.com

Visit the Viking website for the latest edition of this technical data page [www.vikinggroupinc.com](http://www.vikinggroupinc.com)

## 6 INSPECTIONS AND MAINTENANCE

### NOTICE

The owner is responsible for maintaining the fire protection system and devices in proper operating condition. The Deluge Valve must be kept from freezing conditions and physical damage that could impair its operation.

### WARNING

Any system maintenance which involves placing a control valve or detection system out of service may eliminate the Fire Protection capabilities of that system. Prior to proceeding, notify all Authorities Having Jurisdiction. Consideration should be given to employment of a Fire Patrol in the affected areas.

### Inspection

It is imperative that the system be inspected and tested on a regular basis. The frequency of the inspections may vary due to contaminated water supplies, corrosive water supplies or corrosive atmospheres. Also, the alarm devices, detection systems or other connected trim may require a more frequent schedule. For minimum maintenance and inspection requirements, refer to NFPA 25. In addition, the Authority Having Jurisdiction may have additional maintenance, testing, and inspection requirements which must be followed. The following recommendations are minimum requirements.

### Replacing the Diaphragm (disassembling the valve). Refer to Figure 4.

1. Remove the valve from service (refer to the system documentation). Close the main control valve, open the main drain valve. Release the pressure in the priming chamber by opening the emergency release valve.
  2. Remove trim as required to allow removal of cover (1).
  3. Remove the bolts and washers as necessary.
  4. Pull the cover (1) away from body (3).
- NOTE: 4" through 10" valves include 2 studs; the cover must be pulled off the studs carefully to avoid damage to the threads.**
5. Lift and remove diaphragm assembly (2) including the V-ring if present.
  6. To replace the diaphragm (and V-ring, if present), remove from the body of the valve and install the replacement.
  7. Clean all parts and surfaces and reassemble the valve.

## 7 AVAILABILITY

The Viking Model VXD Deluge Valve and accessories are available through a network of Domestic, Canadian, and International Distributors. See the Viking Corporation Web site for your closest distributor or contact The Viking Corporation.

## 8 GUARANTEES

For details of warranty, refer to Viking's current list price schedule or contact Viking directly.

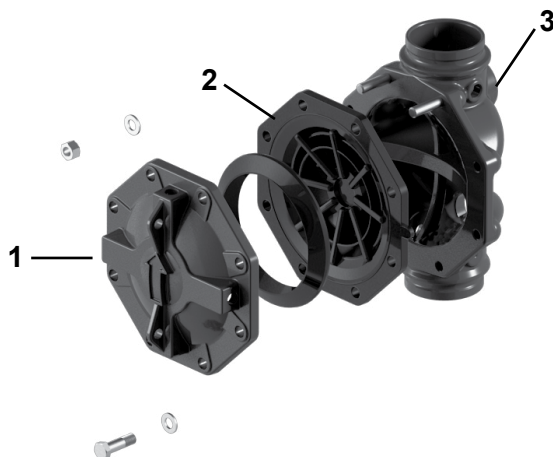

Figure 4: Replacing the Diaphragm



# TECHNICAL DATA

**DELUGE VALVE  
MODEL VXD**

The Viking Corporation, 210 N Industrial Park Drive, Hastings MI 49058  
 Telephone: 269-945-9501 Technical Services: 877-384-5464 Fax: 269-818-1680 Email: techsvcs@vikingcorp.com  
 Visit the Viking website for the latest edition of this technical data page [www.vikinggroupinc.com](http://www.vikinggroupinc.com)

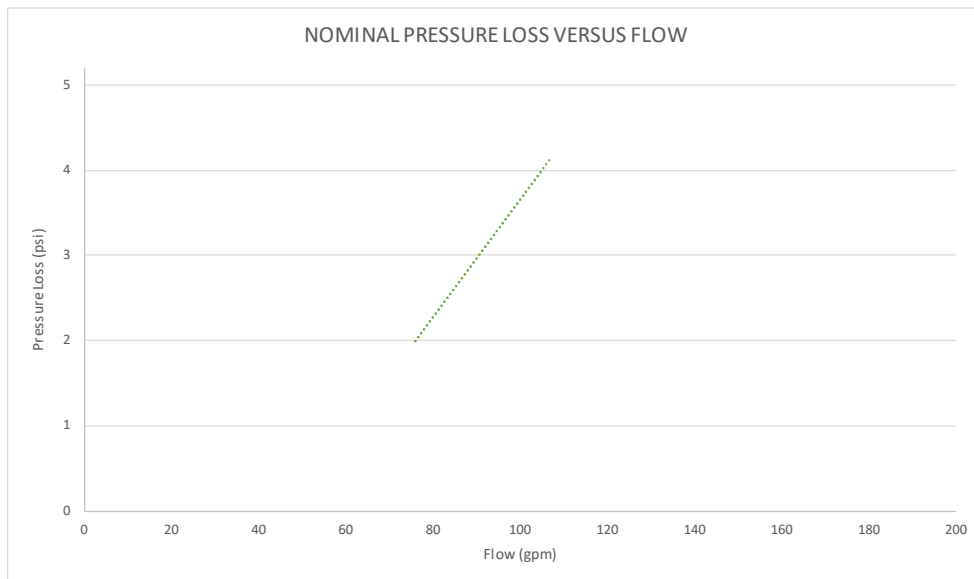

**Figure 4: Hydraulic Performance Data (Friction Loss)  
1-1/2" Valve**

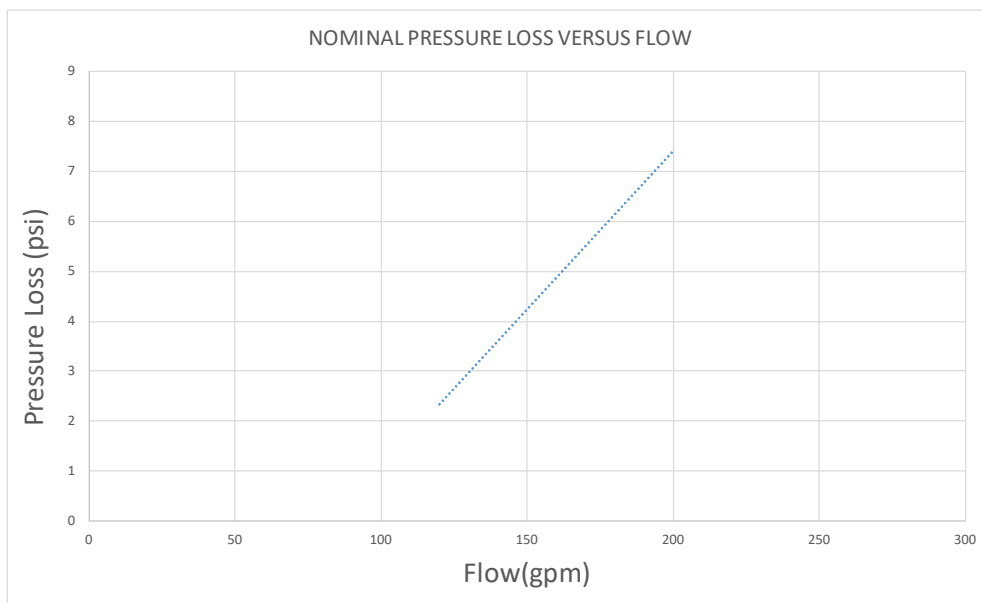

**Figure 5: Hydraulic Performance Data (Friction Loss)  
2" Valve**



# TECHNICAL DATA

**DELUGE VALVE  
MODEL VXD**

The Viking Corporation, 210 N Industrial Park Drive, Hastings MI 49058  
 Telephone: 269-945-9501 Technical Services: 877-384-5464 Fax: 269-818-1680 Email: techsvcs@vikingcorp.com  
 Visit the Viking website for the latest edition of this technical data page [www.vikinggroupinc.com](http://www.vikinggroupinc.com)

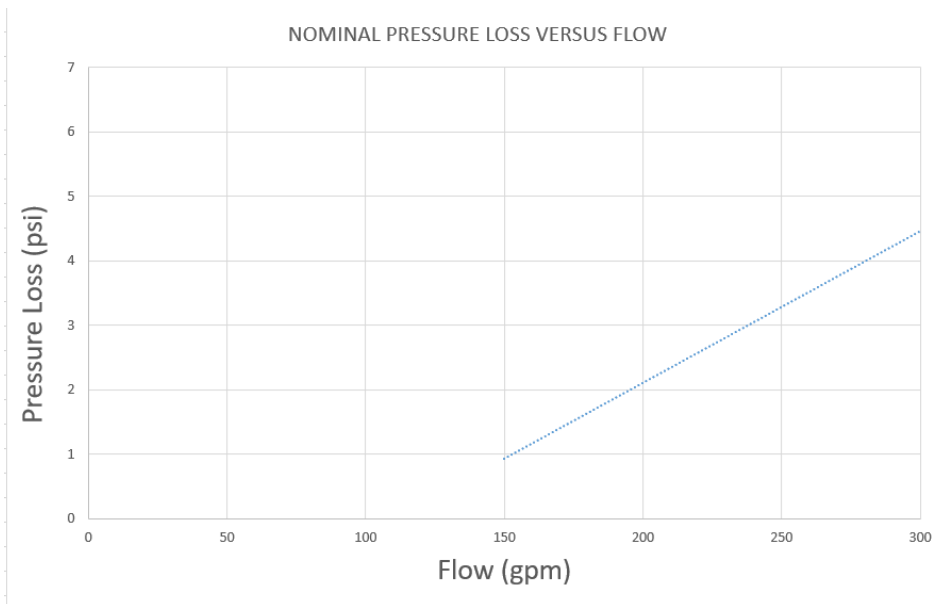

**Figure 6: Hydraulic Performance Data (Friction Loss)  
2-1/2" Valve**

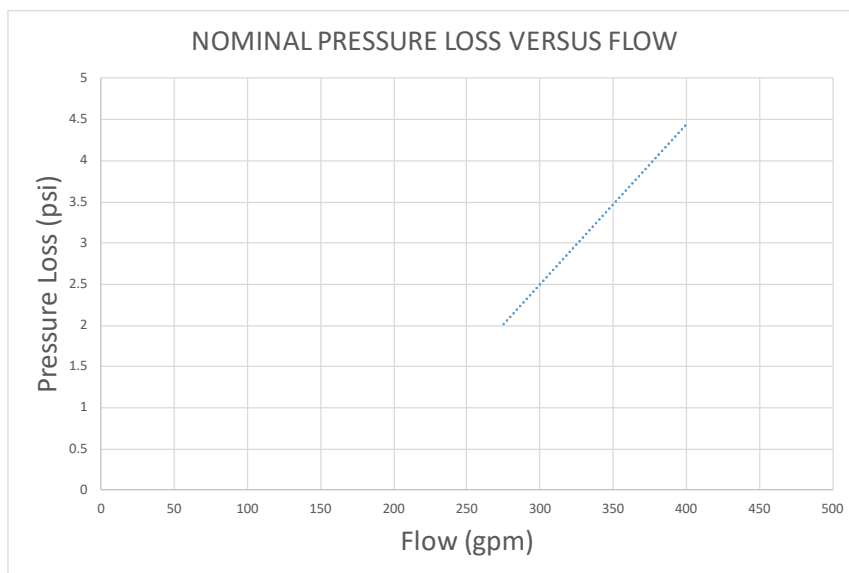

**Figure 7: Hydraulic Performance Data (Friction Loss)  
3" Valve**



# TECHNICAL DATA

**DELUGE VALVE  
MODEL VXD**

The Viking Corporation, 210 N Industrial Park Drive, Hastings MI 49058  
 Telephone: 269-945-9501 Technical Services: 877-384-5464 Fax: 269-818-1680 Email: techsvcs@vikingcorp.com  
 Visit the Viking website for the latest edition of this technical data page [www.vikinggroupinc.com](http://www.vikinggroupinc.com)

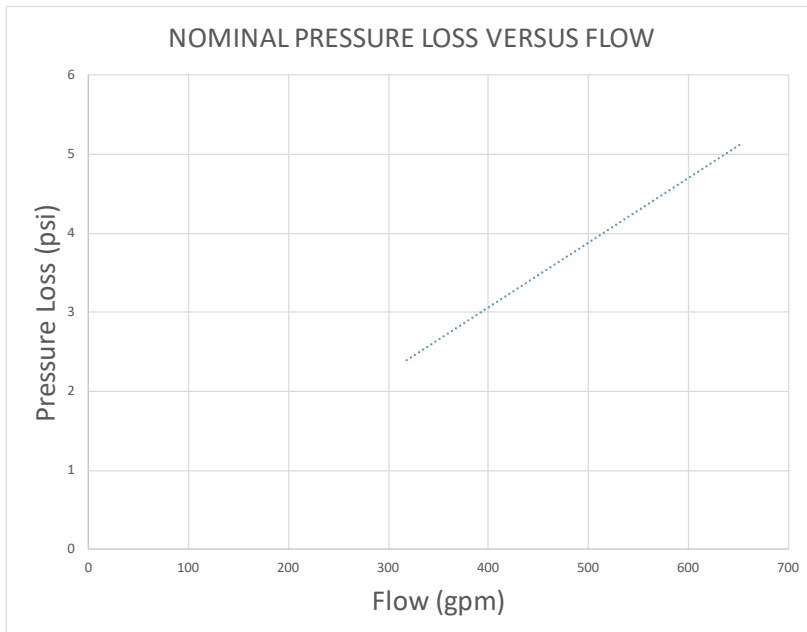

**Figure 8: Hydraulic Performance Data (Friction Loss)  
4" Valve**

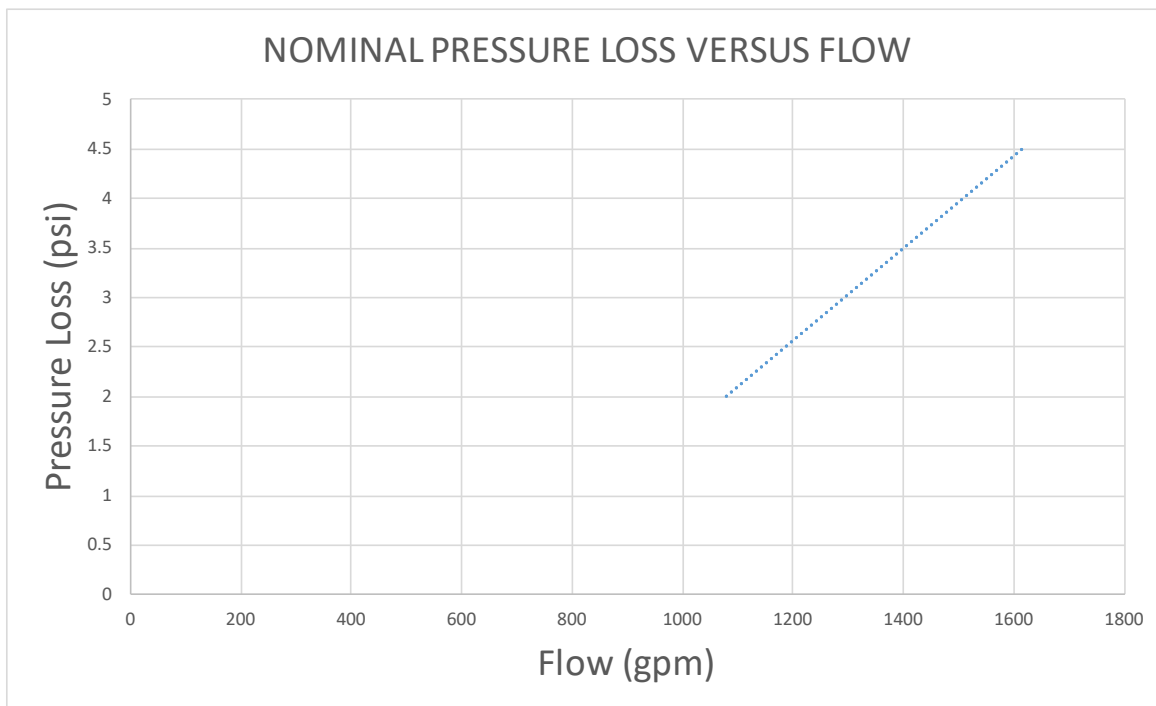

**Figure 9: Hydraulic Performance Data (Friction Loss)  
6" Valve**





# TECHNICAL DATA

## DELUGE VALVE MODEL VXD

The Viking Corporation, 210 N Industrial Park Drive, Hastings MI 49058  
 Telephone: 269-945-9501 Technical Services: 877-384-5464 Fax: 269-818-1680 Email: techsvcs@vikingcorp.com  
 Visit the Viking website for the latest edition of this technical data page [www.vikinggroupinc.com](http://www.vikinggroupinc.com)

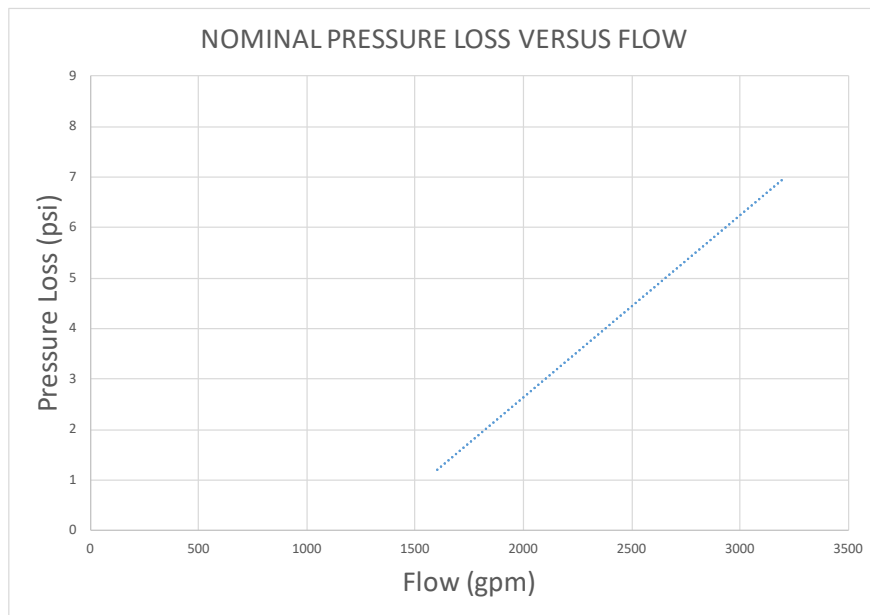

**Figure 10: Hydraulic Performance Data (Friction Loss)  
8" Valve**

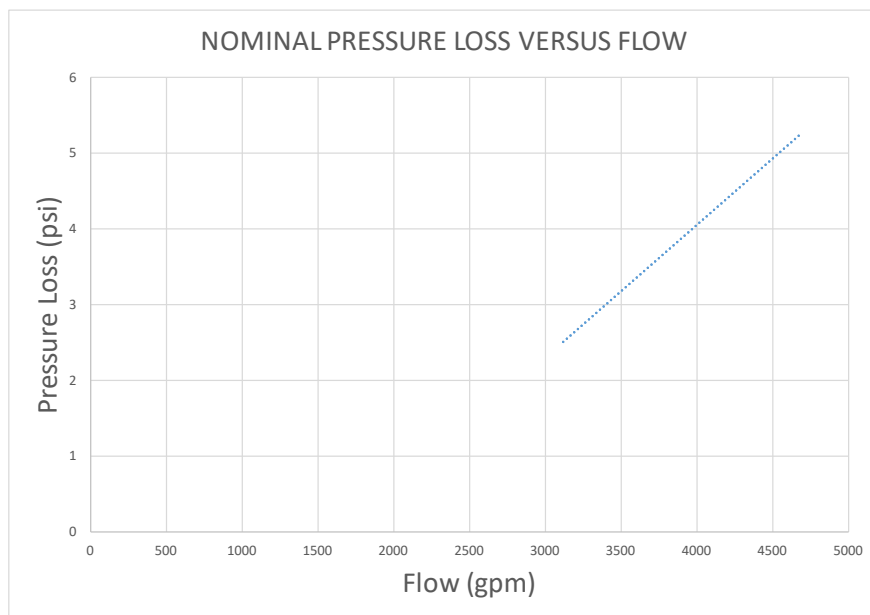

**Figure 11: Hydraulic Performance Data (Friction Loss)  
10" Valve**



# TECHNICAL DATA

## DELUGE VALVE MODEL VXD

The Viking Corporation, 210 N Industrial Park Drive, Hastings MI 49058  
 Telephone: 269-945-9501 Technical Services: 877-384-5464 Fax: 269-818-1680 Email: techsvcs@vikingcorp.com  
 Visit the Viking website for the latest edition of this technical data page [www.vikinggroupinc.com](http://www.vikinggroupinc.com)

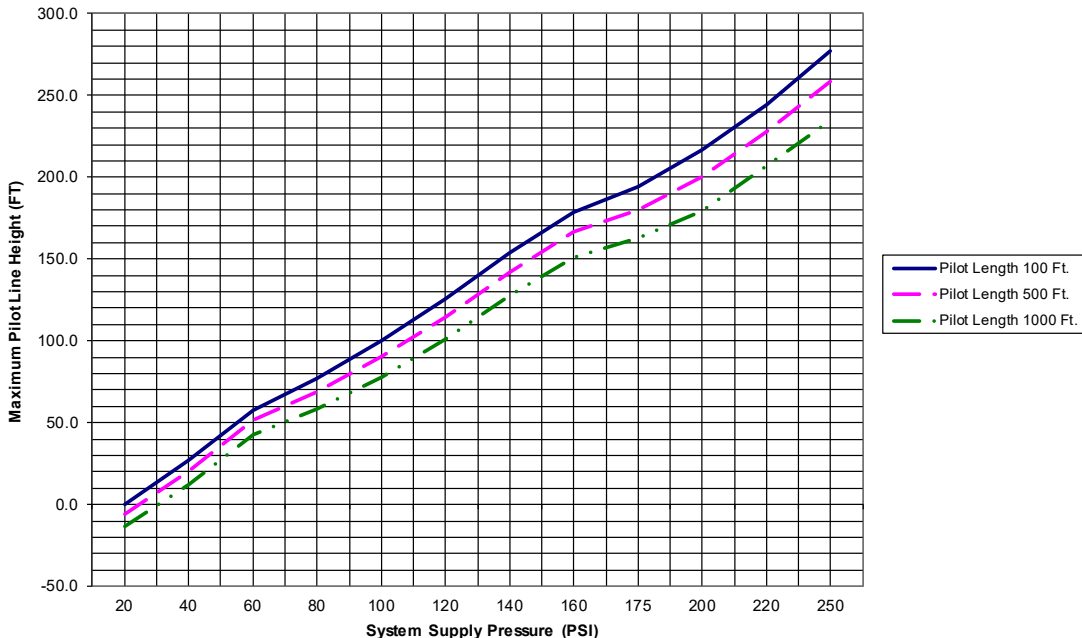

**Figure 12: Maximum Allowable Pilot Heights for Select Lengths of 1/2" Schedule 40 Pipe  
1-1/2" Valve**

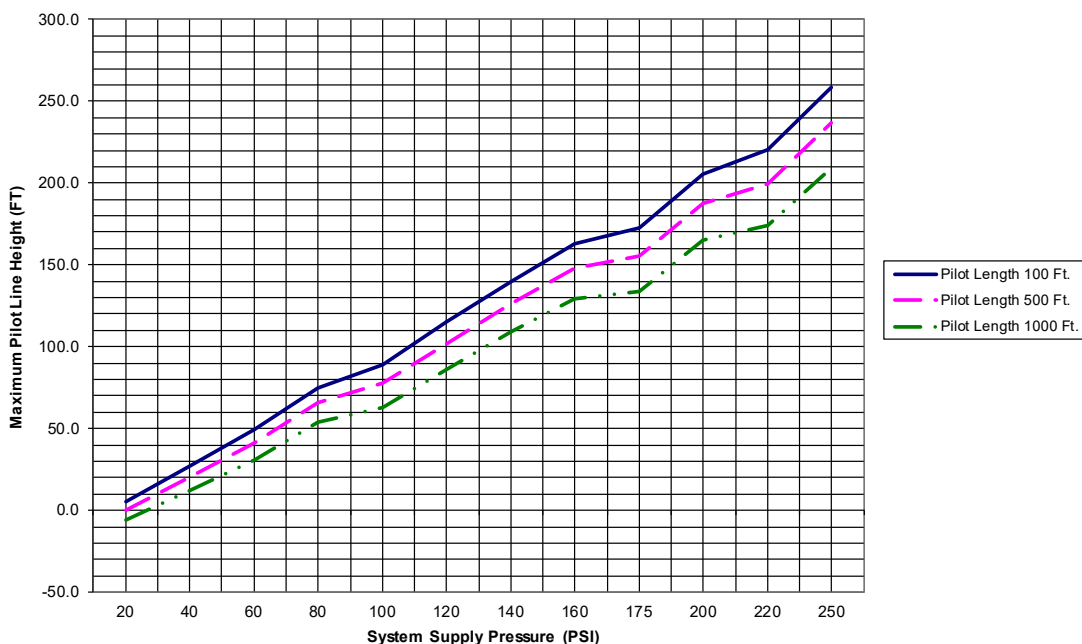

**Figure 13: Maximum Allowable Pilot Heights for Select Lengths of 1/2" Schedule 40 Pipe  
2" Valve**



# TECHNICAL DATA

## DELUGE VALVE MODEL VXD

The Viking Corporation, 210 N Industrial Park Drive, Hastings MI 49058  
 Telephone: 269-945-9501 Technical Services: 877-384-5464 Fax: 269-818-1680 Email: techsvcs@vikingcorp.com  
 Visit the Viking website for the latest edition of this technical data page [www.vikinggroupinc.com](http://www.vikinggroupinc.com)

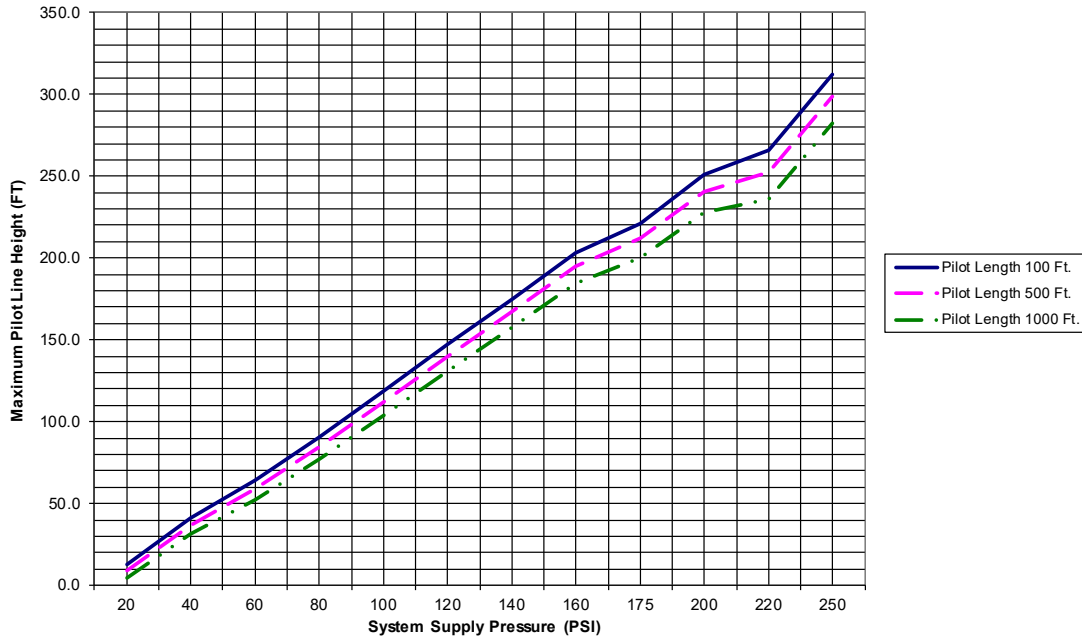

**Figure 14: Maximum Allowable Pilot Heights for Select Lengths of 1/2" Schedule 40 Pipe  
2-1/2" Valve**

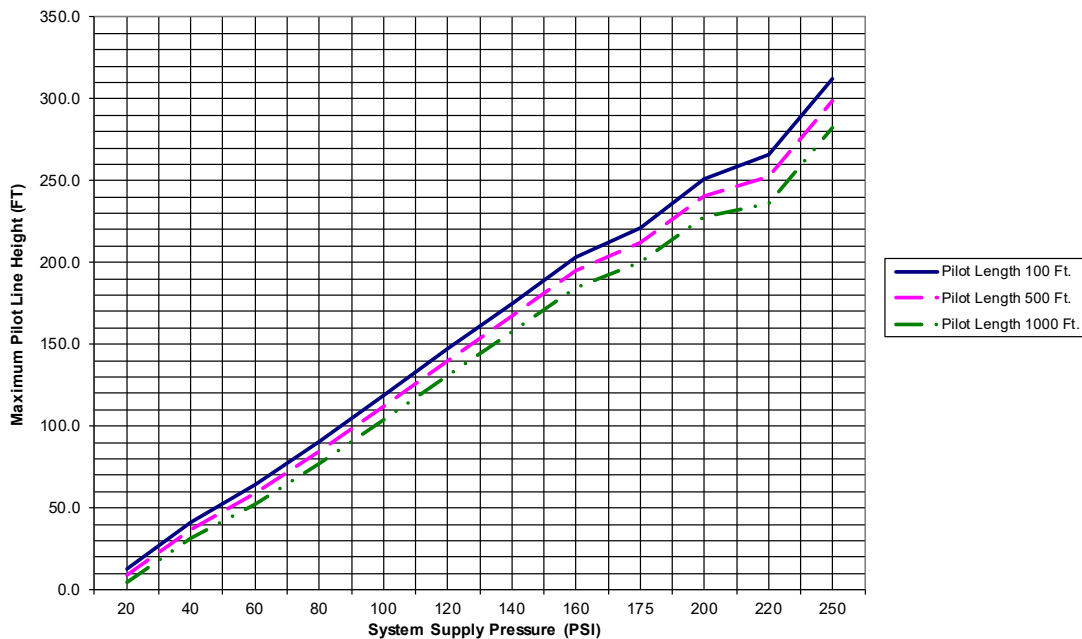

**Figure 15: Maximum Allowable Pilot Heights for Select Lengths of 1/2" Schedule 40 Pipe  
3" Valve**



# TECHNICAL DATA

## DELUGE VALVE MODEL VXD

The Viking Corporation, 210 N Industrial Park Drive, Hastings MI 49058  
 Telephone: 269-945-9501 Technical Services: 877-384-5464 Fax: 269-818-1680 Email: techsvcs@vikingcorp.com  
 Visit the Viking website for the latest edition of this technical data page [www.vikinggroupinc.com](http://www.vikinggroupinc.com)

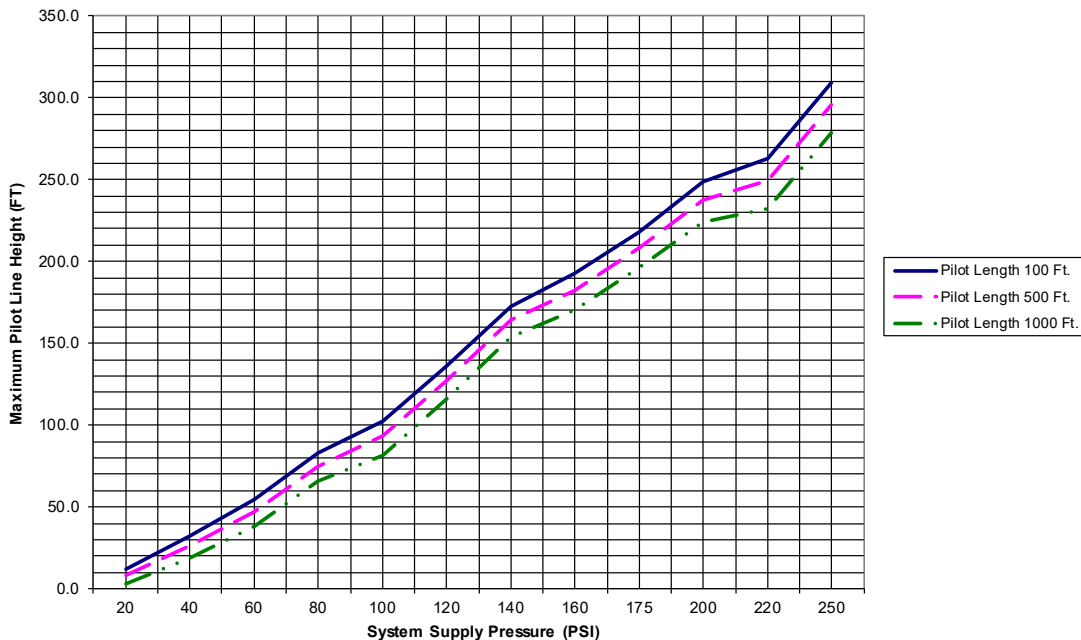

**Figure 16: Maximum Allowable Pilot Heights for Select Lengths of 1/2" Schedule 40 Pipe  
4" Valve**

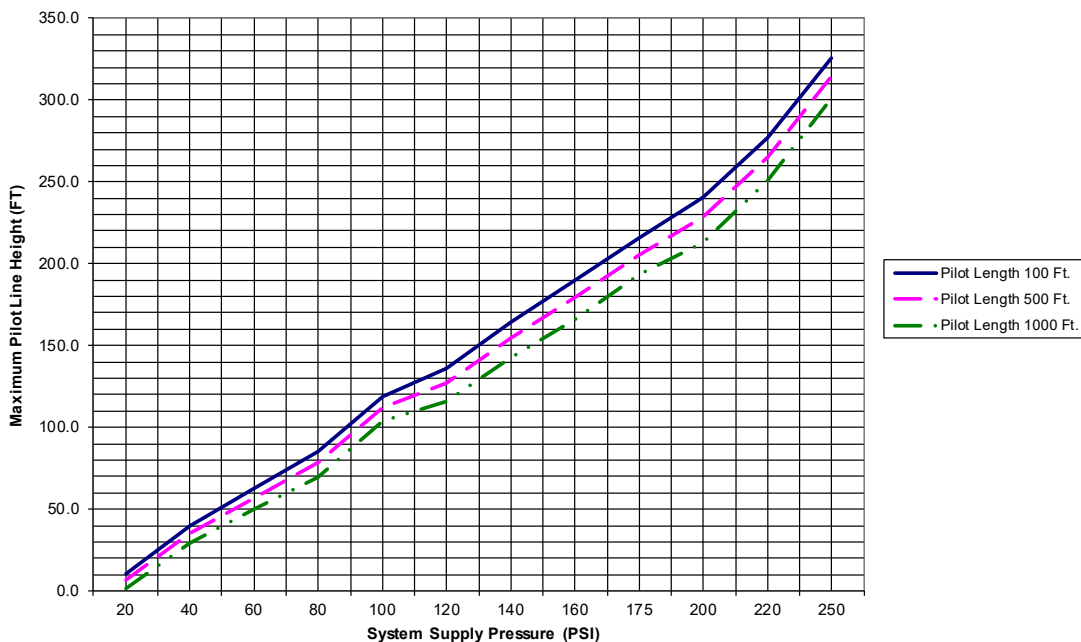

**Figure 17: Maximum Allowable Pilot Heights for Select Lengths of 1/2" Schedule 40 Pipe  
6" Valve**



# TECHNICAL DATA

## DELUGE VALVE MODEL VXD

The Viking Corporation, 210 N Industrial Park Drive, Hastings MI 49058  
 Telephone: 269-945-9501 Technical Services: 877-384-5464 Fax: 269-818-1680 Email: techsvcs@vikingcorp.com  
 Visit the Viking website for the latest edition of this technical data page [www.vikinggroupinc.com](http://www.vikinggroupinc.com)

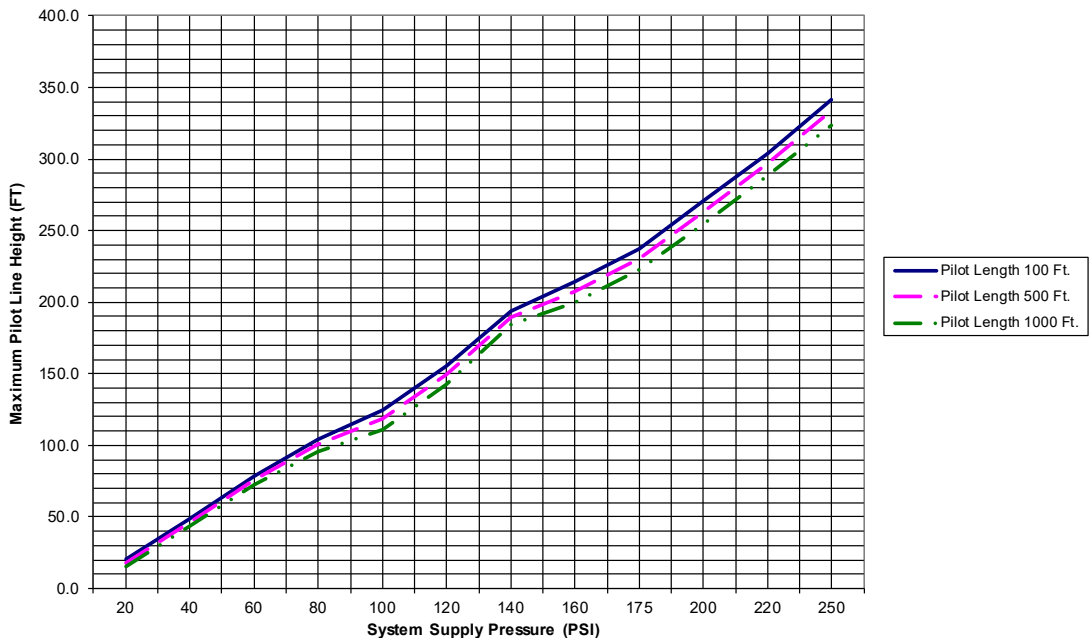

**Figure 18: Maximum Allowable Pilot Heights for Select Lengths of 1/2" Schedule 40 Pipe  
8" Valve**

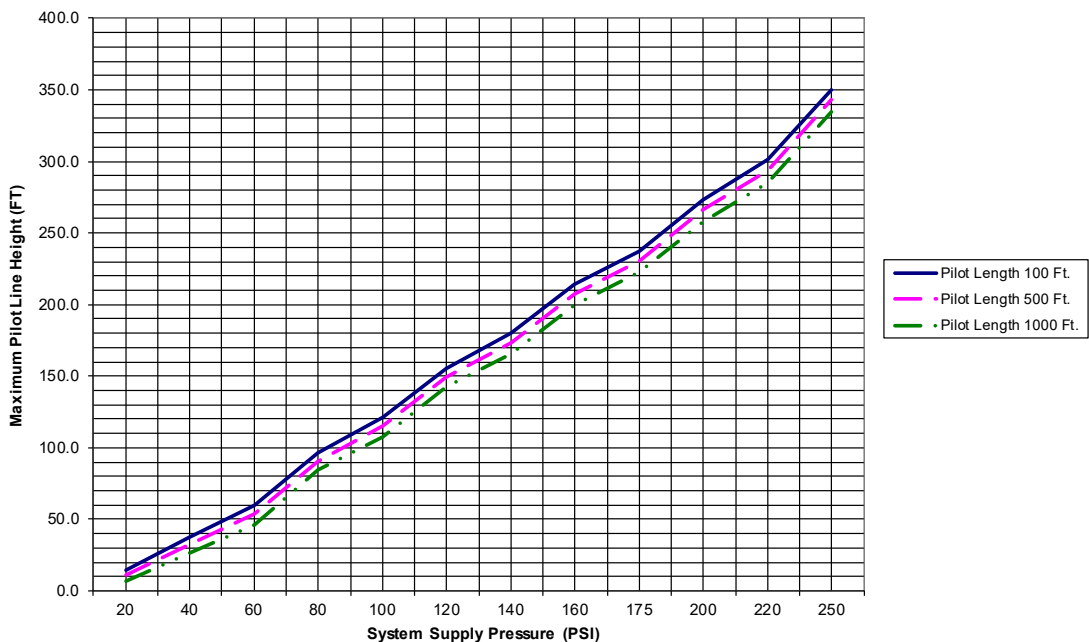

**Figure 19: Maximum Allowable Pilot Heights for Select Lengths of 1/2" Schedule 40 Pipe  
10" Valve**