



TECHNICAL DATA

FPL DETECTOR CABLE

The Viking Corporation, 210 N Industrial Park Drive, Hastings MI 49058

Telephone: 269-945-9501 Technical Services: 877-384-5464 Fax: 269-818-1680 Email: techsvcs@vikingcorp.com

Visit the Viking website for the latest edition of this technical data page.

1. DESCRIPTION

The FPL Detector Cable is a Plenum Fire Alarm cable designed for use in detection circuits. When properly installed in conduit, the FPL Detector Cable meets the requirements for use as the electrical conductor in the detection systems. The FPL Detector Cable consists of 2 number 16 copper conductors or 2 number 18 copper conductors with flexible insulation and jacket. This FPL cable is used in the detector circuit for the Viking Firecycle® III Multi-Cycle Release Control Panel.

Features:

- Non-toxic: No toxic or noxious fumes are emitted during a fire.
- Will not propagate a fire.
- Steel conduit is required.
- Bends easily to match contours for easy installation.
- Can be cut to length in field.
- Cable may be spliced, but all splices must be made in the detector box with a porcelain wire nut.

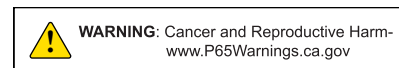

2. LISTINGS AND APPROVALS

cULus Listed (HNIR)

3. TECHNICAL DATA

Specifications:

See Table 1

Materials:

Insulation: Wall thickness 0.007" (0.18 mm)

Jacket: Red, wall thickness 0.014" (.254 mm), Red Plenum PVC

16 Gauge - nominal outside diameter .330" (8.3 mm)

18 Gauge - nominal outside diameter .136" (3.45 mm)

Color Code: black, red

Ordering Information:

Part Number, 16 AWG: 19749

Part Number, 18 AWG: 19750

Available since 2015

4. INSTALLATION

I. General

NOTICE

Prior to installation in ambient air temperature below 40 °F (4 °C), this cable should be climatized at room temperature for 24 hours.

1. Cut cable to proper length. Allow for change in direction, ducts, beams, etc.
2. Remove approximately 6" (150 mm) of the cable jacket from the end of the detector cable.
3. Remove the detector box cover.
4. Strip approximately 1/2" (15 mm) of insulation from the end of each conductor.
5. Connect both conductors of one detector cable to one lead wire of detector using porcelain wire connectors. The two conductors in each cable must be connected to only one detector lead wire. Connect the other detector lead wire to the two outgoing conductors for the next detector in series.
6. Install detector box cover.
7. The detector cable may be spliced. However, the splice must be made using a detector box as noted below in Paragraphs II and III.
8. Install both ends of detector loop in VFR400 Release Control Panel.

II. Splicing Procedure:

A. To splice FPL Detector Cable:

1. A junction box is required. Use either option a or b below.
 - a. For Model B Detector use a detector box assembly (part number 04629A) with a 1/2" (15 mm) metal pipe plug (not included) installed in the 1/2" (15 mm) NPT threaded detector probe connection or,



TECHNICAL DATA

FPL DETECTOR CABLE

The Viking Corporation, 210 N Industrial Park Drive, Hastings MI 49058

Telephone: 269-945-9501 Technical Services: 877-384-5464 Fax: 269-818-1680 Email: techsvcs@vikingcorp.com

Visit the Viking website for the latest edition of this technical data page.

- b. A steel electrical junction box with ½" (15 mm) NPT connections.

NOTICE

FPL DETECTOR CABLE MUST BE INSTALLED IN STEEL CONDUIT THREADED INTO THE ½" NPT CONNECTIONS OF THE JUNCTION BOX USED.

- c. For Model C-OH Systems install a standard octagonal approved electrical box and conduit.
- Porcelain wire connectors are required. Use Viking part number 04631A.
 - With the cover removed from junction box used, pull the ends of the two FPL Cables to be spliced, into the open junction box.
 - Slit and strip away enough cable jacket to expose conductors.
 - Strip approximately ½" (13 mm) of insulation from the ends of each conductor.
 - For Model B Detector, use the porcelain wire connectors to connect the wire leads of the detector probe to the cable conductors as shown in Figure 1 and described in steps "a" through "d" below.
 - Twist the pair of cable wires entering the junction box together with one of the wire leads from the detector probe.
 - Secure the twisted wire connection by installing a porcelain wire connector.
 - Twist the pair of cable wires exiting the junction box together with the remaining (unused) wire lead from the detector probe.
 - Secure the twisted wire connection by installing a porcelain wire connector.
 - For Model C-OH Detector, attach cable ends to screw terminals furnished in detector.
 - Install the junction box cover, tightening all cover screws.
 - Verify that the detection circuit complies with Installation section above.

B. To Splice FPL Detector Cable to existing aluminum sheathed FPL Cable:

- A detector box is required. Use either option a or b below.
 - Use a detector box assembly (part number 04629A) with a ½" (15 mm) metal pipe plug (not included) installed in the ½" (15 mm) NPT threaded detector probe connection or,
 - Make the connection inside the detector box.
- Porcelain wire connectors are required. Use Viking part number 04631A (two are included with Model B Detectors or may be ordered separately).
- Refer to instructions provided in this technical data for splicing FPL Cable and/or making connections to a detector probe.
- Install the detector box cover and tighten all cover screws.
- Verify that the detection circuit complies with Installation section above.

5. OPERATION

Refer to the associated Firecycle® Multi-Cycle System Data Pages.

6. INSPECTIONS, TESTS, AND MAINTENANCE

No maintenance is required except for annual testing of entire circuit in accordance with manufacturers instructions and NFPA 72.

Table 1 - Specifications

Part Number	# of Conductors	AWG Size	Cable O.D.	Capacitance (p/F/ft)	Weight		Nominal Resistance (Ohm/1000 ft) @ 68°F / 20°C
					lbs / ft	kg / m	
19749	2	16	.33 / 8,3	16.3	62.8 / 1000	28.5 / 305	4.1
19750	2	18	.136 / 3.45	31	70.4 / 1000	31.9 / 305	6.7



TECHNICAL DATA

FPL DETECTOR CABLE

The Viking Corporation, 210 N Industrial Park Drive, Hastings MI 49058

Telephone: 269-945-9501 Technical Services: 877-384-5464 Fax: 269-818-1680 Email: techsvcs@vikingcorp.com

Visit the Viking website for the latest edition of this technical data page.

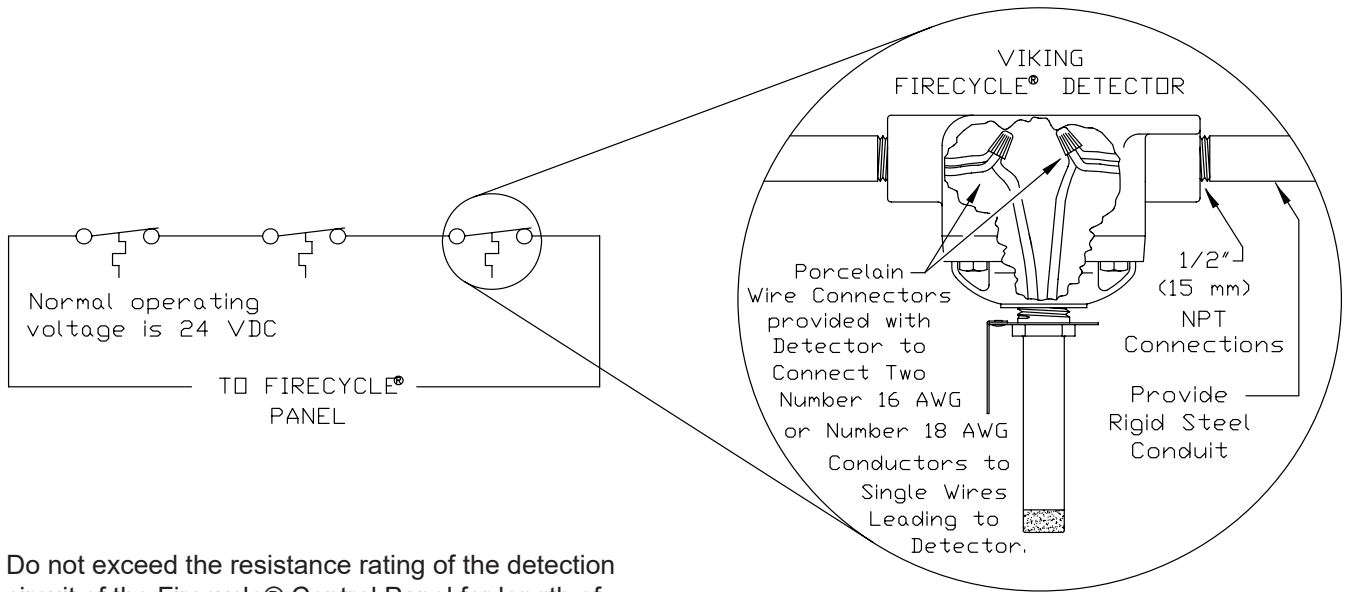

Do not exceed the resistance rating of the detection circuit of the Firecycle® Control Panel for length of detection circuit and number of detectors allowed.

Figure 1 - Model B Detector Wiring Diagram

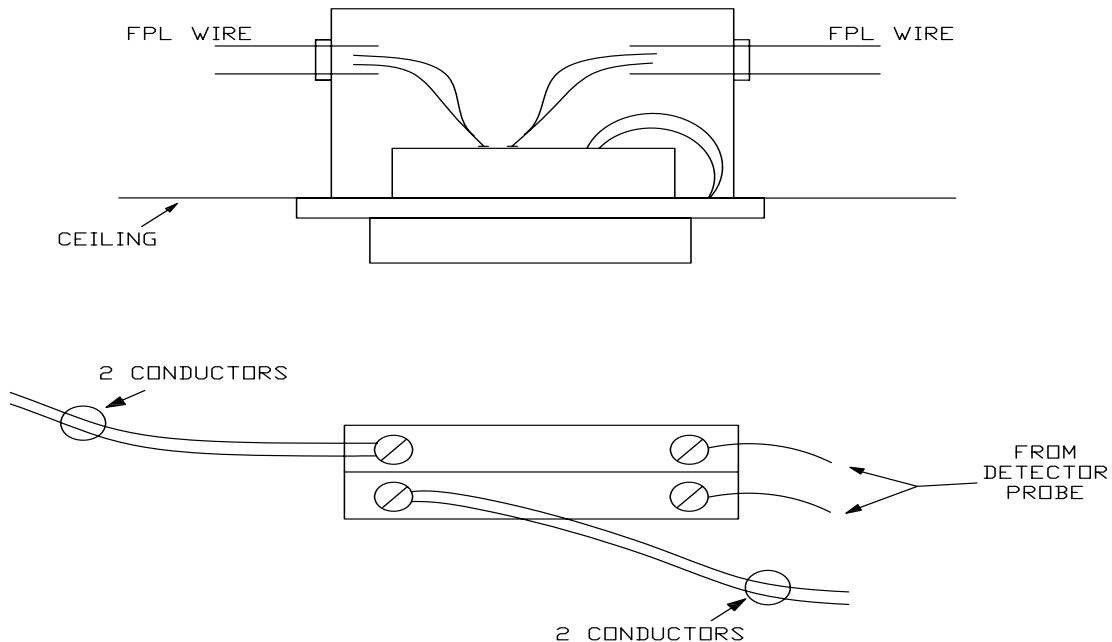

Figure 2 - Model C-OH Detector Wiring Diagram