



TECHNICAL DATA

FOMTEC BETWEEN FLANGE BFZ INDUCTORS 4" (DN100), 6" (DN150) & 8" (DN200)

The Viking Corporation, 210 N Industrial Park Drive, Hastings MI 49058

Telephone: 269-945-9501 Technical Services: 877-384-5464 Fax: 269-818-1680 Email: techsvcs@vikingcorp.com

Visit the Viking website for the latest edition of this technical data page www.vikinggroupinc.com

1. DESCRIPTION

FomTec BFZ Inductors are used to mix foam concentrate with water when the foam concentrate is supplied from a tank at atmospheric pressure. The BFZ inductor can be installed in deluge systems where sprinklers are used, such as storage facilities and aircraft hangars. The inductors are connected to the water line.

Features:

- Fixed between-flange installation
- High back pressure
- High suction height
- Can be customized to handle various flow rates
- Compatible with alcohol resistant foam concentrates

2. LISTINGS AND APPROVALS

No listings or approvals.

3. MANUFACTURER

Dafo Fomtec AB, Sweden

4. TECHNICAL DATA

Specifications:

See Tables 1 and 2

Working Range: See Figures 3 - 6.

Proportioning Rate: 1%, 3%, or 6%

Standard Suction Height: 9.84 feet (3 m)

NOTE: Induction performance and suction height can be adjusted up to a physical limit of approximately 26 feet (8 m).

Minimum Inlet Pressure: 58 PSI (4 BAR)

Maximum Inlet Pressure: 232 PSI (16 BAR)

Pressure Drop: 35%

Material Standards:

Body - Bronze

Ordering Information:

When ordering Inductor: Required GPM and PSI at the INLET of the inductor and the centerline of the foam inlet, above the bottom of the atmospheric storage tank, must be provided in order to properly manufacture the inductor.

See Table 1.

5. INSTALLATION

The BFZ Inductor is installed inside the pipe work between two flanges. The atmospheric storage tank and foam concentrate shut-off valve are installed prior to the inductor.

6. OPERATION

The BFZ Inductor works using the injector principle, i.e. foam concentrate is sucked into the inductor without using a foam pump. Both low and high viscosity concentrates can be used in conjunction with the BFZ.

Depending on the requested flow, pressure, foam concentrate type and proportioning ratio, the inductor will be equipped with the exact orifice at the entry of the foam pipe. Induction performance and suction height can be adjusted up to a physical limit of approximately 26 feet (8 m).

To ensure accurate proportioning over the flow range of the inductor, minimum water inlet pressure of 58 psi (4 BAR) must be available during operation of the system.

Please review the inductor dimension table for information on the minimum recommended length of straight pipe required upstream and downstream from the controller.

7. INSPECTIONS, TESTS AND MAINTENANCE

NOTICE

The owner is responsible for maintaining the fire protection system and devices in proper operating condition. For minimum maintenance and inspection requirements, refer to recognized standards such as those produced by NFPA, LPC, and VdS, which describe care and maintenance of sprinkler systems. In addition, the Authority Having Jurisdiction may have additional maintenance, testing, and inspection requirements that must be followed.





TECHNICAL DATA

**FOMTEC BETWEEN FLANGE
BFZ INDUCTORS 4" (DN100),
6" (DN150) & 8" (DN200)**

The Viking Corporation, 210 N Industrial Park Drive, Hastings MI 49058

Telephone: 269-945-9501 Technical Services: 877-384-5464 Fax: 269-818-1680 Email: techsvcs@vikingcorp.com

Visit the Viking website for the latest edition of this technical data page www.vikinggroupinc.com

⚠ WARNING

Any system maintenance or testing that involves placing a control valve or detection system out of service may eliminate the fire protection of that system. Prior to proceeding, notify all Authorities Having Jurisdiction. Consideration should be given to employment of a fire patrol in the affected area.

8. AVAILABILITY

FomTec Inductors are available through a network of domestic and international distributors. See the Viking web site for closest distributor or contact The Viking Corporation.

9. GUARANTEE

For details of warranty, refer to Viking's current list price schedule or contact Viking directly.

Inductors without balancing valve

To get 34% pressure drop over the inductor and get the inductor's proper function, the system after the inductor shall have a K-factor that is 27% larger than the K-factor of the inductor when using 3% foam and 30.5% higher when using 6% foam. If the K-factor on the system after the inductor is less than 22% larger than the K-factor of the inductor, then the suction ceases completely. If the K-factor on the system after the inductor is more than 27% (3% foam) larger than the K-factor of the inductor, the pressure drop over the inductor increases, but the flow is constant when you have the same inlet pressure on the inductor.

Calculations:

$$\frac{(Q_v + Q_s) \sqrt{H}}{Q_v \sqrt{0.66 H}} = 1.27$$

$$\frac{(Q_v + Q_s) \sqrt{H}}{Q_v \sqrt{0.66 H}} = 1.305$$

$Q_s = 3\%$

$Q_v =$ Water Flow in GPM

$Q_s =$ Foam Concentrate Flow in GPM

$H =$ Water pressure before the inductor in PSI

$Q_s = 6\%$

$Q_v =$ Water Flow in GPM

$Q_s =$ Foam Concentrate Flow in GPM

$H =$ Water pressure before the inductor in PSI

TABLE 1: SPECIFICATIONS

Size	FomTec Model Number	Viking Part No.	Foam Inlet	K-Factor Range		Min. Flow		Max. Flow		Between Flange Proportions	For use with Foam Concentrate Viking Part No.	
				U.S.	Metric	gpm	(L/m)	gpm	(L/m)		Americas	EMEA/APAC
4" (DN 100)	BFZ 4"	F15922	1-1/2"	19.0 - 69.4	275 - 1000	145	550	872	3300	2-9/32" (58 mm)	F20335 F20336 F20227 F21791	AFFF1S AFFF3S ARC3X3S AFFF3M
6" (DN 150)	BFZ 6"	F15923	2"	38.1 - 138.8	550 - 2000	290.5	1100	1743.5	6600	2-3/4" (70 mm)	F20335 F20336 F20227 F21791	AFFF1S AFFF3S ARC3X3S AFFF3M
8" (DN 200)	BFZ 8"	F15924	2-1/2"	57.2 - 208.3	825 - 3000	436	1650	2615	9900	3-11/32" (85 mm)	F20335 F20336 F20227 F21791	AFFF1S AFFF3S ARC3X3S AFFF3M
8" (DN 200)	BFZ 8" S	F15925	3"	95.4 - 347.2	1375 - 5000	435.8	1650	4358.8	16500	3-11/32" (85 mm)	F20335 F20336 F20227 F21791	AFFF1S AFFF3S ARC3X3S AFFF3M



TECHNICAL DATA

**FOMTEC BETWEEN FLANGE
BFZ INDUCTORS 4" (DN100),
6" (DN150) & 8" (DN200)**

The Viking Corporation, 210 N Industrial Park Drive, Hastings MI 49058
 Telephone: 269-945-9501 Technical Services: 877-384-5464 Fax: 269-818-1680 Email: techsvcs@vikingcorp.com
 Visit the Viking website for the latest edition of this technical data page www.vikinggroupinc.com

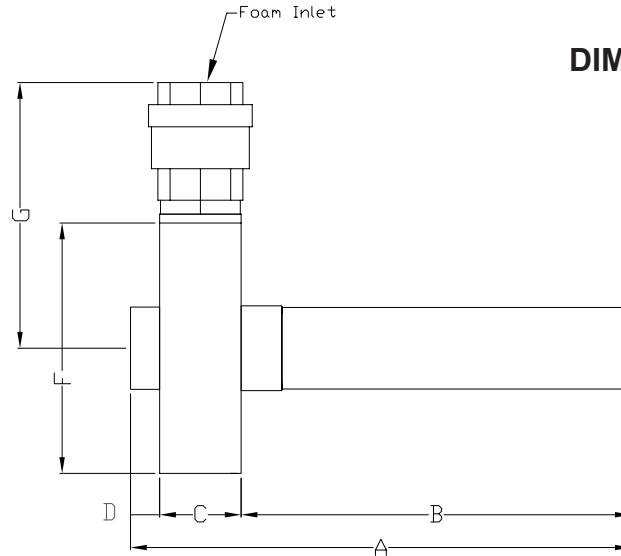

**FIGURE 1
DIMENSIONS BFZ 4 AND BFZ 6**

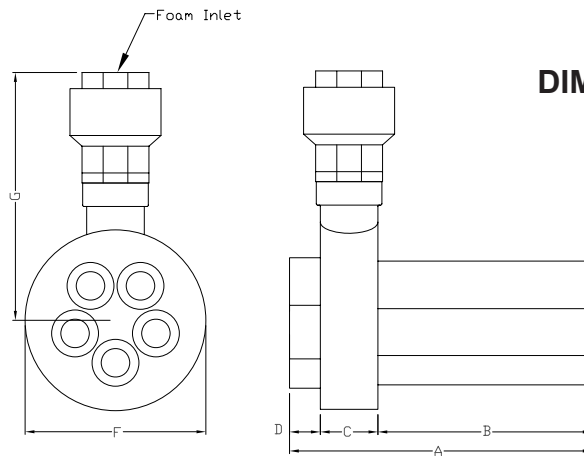

**FIGURE 2
DIMENSIONS BFZ 8 AND BFZ 8S**

Size	Foam Inlet (Grooved)	A Inches (mm)	B Inches (mm)	C Inches (mm)	D Inches (mm)	F Inches (mm)	G Inches (mm)	J*	Weight
4" (DN 100)	1-1/2" (38.1)	16-9/16" (421)	13-1/2" (343)	2-1/4" (58)	3/4" (20)	6-5/16" (160)	7-5/16" (187)	20" (51 cm)	15.4 lbs. (7 kg)
6" (DN 150)	2" (50.8)	16-15/16" (430)	13-3/16" (335)	2-3/4" (70)	1" (25)	8-7/16" (215)	9" (230)	30" (77 cm)	46.2 lbs. (21 kg)
8" (DN 200)	2 1/2" (63.4)	17-1/8" (435)	13" (330)	3-3/8" (85)	1" (25)	10-5/8" (270)	13-3/8" (340)	40" (102 cm)	88.1 lbs. (40 kg)
8" S (DN 200)	3" (76.2)	16-15/16" (430)	13" (330)	3-3/8" (85)	9/16" (15)	10-5/8" (270)	14-9/16" (370)	40" (102 cm)	101.4 lbs. (46 kg)

* Straight pipe length required upstream and downstream
Dimensions are approximate and subject to change without notice.



TECHNICAL DATA

**FOMTEC BETWEEN FLANGE
BFZ INDUCTORS 4" (DN100),
6" (DN150) & 8" (DN200)**

The Viking Corporation, 210 N Industrial Park Drive, Hastings MI 49058
 Telephone: 269-945-9501 Technical Services: 877-384-5464 Fax: 269-818-1680 Email: techsvcs@vikingcorp.com
 Visit the Viking website for the latest edition of this technical data page www.vikinggroupinc.com

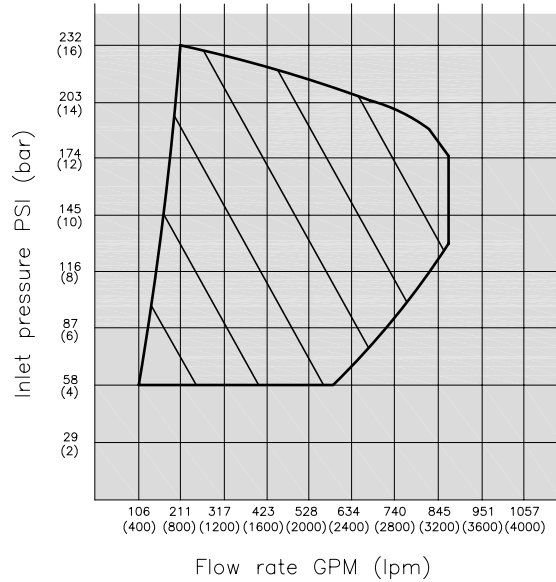

**FIGURE 3
WORKING RANGE OF BFZ 4"**

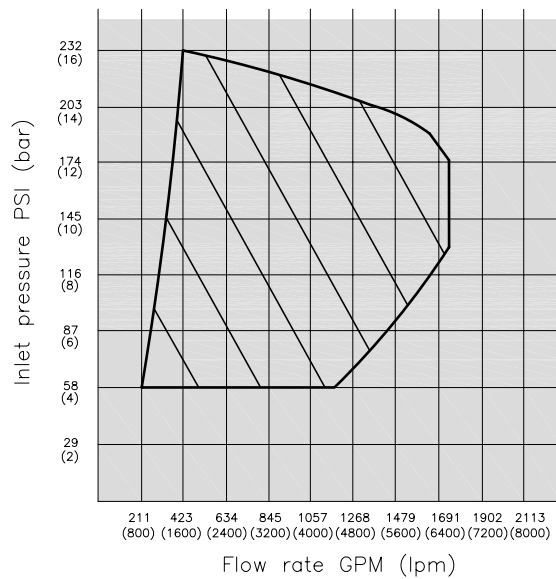

**FIGURE 4
WORKING RANGE OF BFZ 6"**



TECHNICAL DATA

**FOMTEC BETWEEN FLANGE
BFZ INDUCTORS 4" (DN100),
6" (DN150) & 8" (DN200)**

The Viking Corporation, 210 N Industrial Park Drive, Hastings MI 49058
 Telephone: 269-945-9501 Technical Services: 877-384-5464 Fax: 269-818-1680 Email: techsvcs@vikingcorp.com
 Visit the Viking website for the latest edition of this technical data page www.vikinggroupinc.com

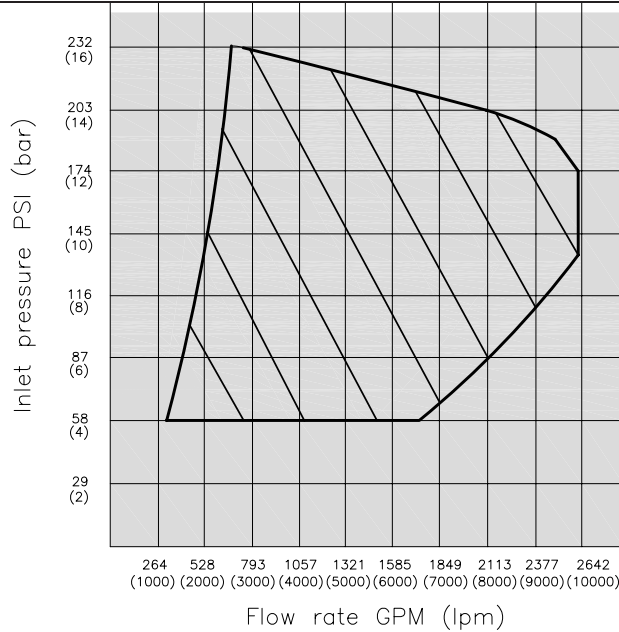

**FIGURE 5
WORKING RANGE OF BFZ 8"**

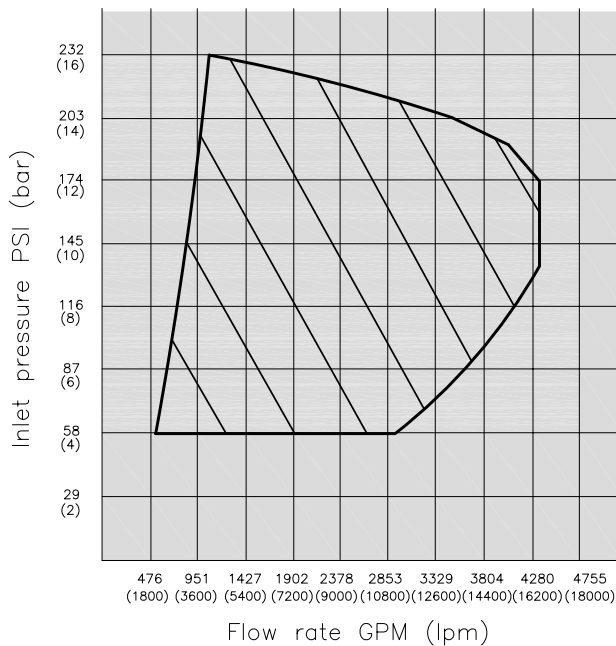

**FIGURE 6
WORKING RANGE OF BFZ 8" S**