



TECHNICAL DATA

FREEDOM® RESIDENTIAL HORIZONTAL SIDEWALL SPRINKLER VK460 (K5.8)

The Viking Corporation, 210 N Industrial Park Drive, Hastings MI 49058

Telephone: 269-945-9501 Technical Services: 877-384-5464 Fax: 269-818-1680 Email: techsvcs@vikingcorp.com

Visit the Viking website for the latest edition of this technical data page. www.vikinggroupinc.com

1. DESCRIPTION

Viking Freedom® Residential Horizontal Sidewall Sprinkler VK460 is a small, thermosensitive, glass-bulb residential sprinkler available in several different finishes and temperature ratings to meet varying design requirements. The Electroless Nickel PTFE (ENT) coating has been investigated for installation in corrosive atmospheres and is C-UL-US-EU Listed as corrosion resistant as indicated in the Approval Chart. The orifice design, with a K-Factor of 5.8 (83.6 metric†), allows efficient use of available water supplies for the hydraulically designed fire-protection system. The glass bulb operating element and special deflector characteristics meet the challenges of residential sprinkler standards.

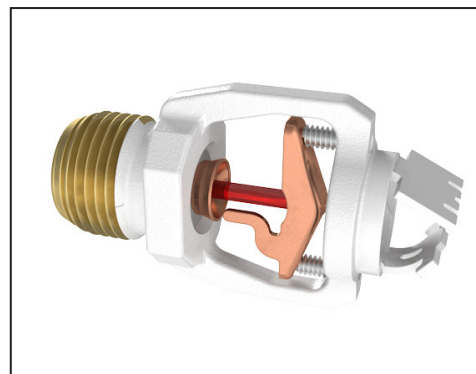

2. LISTINGS AND APPROVALS

 UL Listed (C-UL-US-EU): Category VKKW

 VdS Approved



WARNING: Cancer and Reproductive Harm-
www.P65Warnings.ca.gov

Refer to the Approval Chart and Design Criteria for C-UL-US-EU Listing requirements that must be followed.

3. TECHNICAL DATA

Specifications:

Available since 2007.

Minimum Operating Pressure: 7 psi (0.5 bar).

Maximum Working Pressure: 175 psi (12 bar). Factory tested hydrostatically to 500 psi (34.5 bar).

Thread size: 1/2" (15 mm) NPT

Nominal K-Factor: 5.8 U.S. (83.6 metric†)

† Metric K-factor measurement shown is in Bar. When pressure is measured in kPa, divide the metric K-factor shown by 10.0.

Glass-bulb fluid temperature rated to -65 °F (-55 °C)

Overall Length: 2-1/2" (63.5 mm)

Covered by the following US Patent Nos.: 7,854,269 and 7,712,218

Material Standards:

Frame Casting: Brass UNS-C84400 or QM Brass

Deflector: Brass UNS-C23000 or Phosphor Bronze UNS-C51000

Bulb: Glass, nominal 3 mm diameter

Belleville Spring Sealing Assembly: Nickel Alloy, coated on both sides with PTFE Tape

Pip Cap and Insert Assembly: Copper UNS-C11000 and Stainless Steel UNS-S30400

Compression Screws: 18-8 Stainless Steel

Yoke: Phosphor Bronze UNS-C51000

Available Finishes and Temperature Ratings:

Finish	Brass	Chrome	White Polyester	Black Polyester	ENT
Suffix	A	F	M-/W	M-/B	JN
Temperature	155 °F (68 °C)	175 °F (79 °C)	--	--	--
Suffix	B	D	--	--	--

Ordering Information: See Table 1.

4. INSTALLATION

Refer to appropriate NFPA Installation Standards.

5. OPERATION

During fire conditions, the heat-sensitive liquid in the glass bulb expands, causing the glass to shatter, releasing the yoke, pip cap, and sealing spring assembly. Water flowing through the sprinkler orifice strikes the sprinkler deflector, forming a uniform spray pattern to extinguish or control the fire.

6. INSPECTIONS, TESTS AND MAINTENANCE

Refer to NFPA 25 for Inspection, Testing and Maintenance requirements.



TECHNICAL DATA

FREEDOM® RESIDENTIAL HORIZONTAL SIDEWALL SPRINKLER VK460 (K5.8)

The Viking Corporation, 210 N Industrial Park Drive, Hastings MI 49058

Telephone: 269-945-9501 Technical Services: 877-384-5464 Fax: 269-818-1680 Email: techsvcs@vikingcorp.com

Visit the Viking website for the latest edition of this technical data page. www.vikinggroupinc.com

7. AVAILABILITY

The Viking Model VK460 Sprinkler is available through a network of domestic and international distributors. See The Viking Corporation web site for the closest distributor or contact The Viking Corporation.

8. GUARANTEE

For details of warranty, refer to Viking's current list price schedule or contact Viking directly.

TABLE 1: ORDERING INFORMATION
Instructions: Using the sprinkler base part number,
(1) add the suffix for the desired Finish
(2) add the suffix for the desired Temperature Rating.

Sprinkler Base Part No.	Size		1: Finishes		2: Classifications and Temperature Ratings				
	NPT Inch	BSP mm	Description	Suffix ¹	Classification	Nominal Rating	Bulb Color	Max. Ambient Ceiling Temperature ³	Suffix
13933	1/2	--	Brass	A	Ordinary	155 °F (68 °C)	Red	100 °F (38 °C)	B
			Chrome	F	Intermediate	175 °F (79 °C)	Yellow	150 °F (65 °C)	D
			White Polyester ^{4,5}	M-/W					
			Black Polyester ^{4,5}	M-/B					
			ENT ^{4,5}	JN					

Example: 13933AB = VK460 with Brass Finish and 155 °F (68 °C) Nominal temperature rating. This sprinkler is to be installed into an area with a maximum ambient temperature of 100 °F (38 °C) meaning if the area will experience temperatures above the maximum ambient rating, you shall use a higher temperature-rated sprinkler.

Accessories

Sprinkler Wrenches (see Figure 1):

- A. Standard Wrench: Part No. 21475M/B (available since 2017).
- B. Recessed Socket Wrench: Part No. 13655W/B² (available since 2018).
- C. Protective Sprinkler Cap/Escutcheon installation tool⁶ 15915 (available since 2010).

Sprinkler Cabinet:

- A. Up to 6 sprinklers: Part number 01724A (available since 1971).
- B. 6-12 Sprinklers: Part number 01725A (available since 1971).

Footnotes

1. Where a dash (-) is shown in the Finish suffix designation, insert the desired Temperature Rating suffix. See example above.
2. Requires a 1/2" ratchet which is not available from Viking.
3. Based on NFPA 13, NFPA 13R, and NFPA 13D. Other limits may apply, depending on fire loading, sprinkler location, and other requirements of the Authority Having Jurisdiction. Refer to specific installation standards.
4. UL Listed as corrosion resistant.
5. The corrosion resistant coatings have passed the standard corrosion test required by the approving agencies indicated in the Approval Chart. These tests cannot and do not represent all possible corrosive environments. Prior to installation, verify through the end-user that the coatings are compatible with or suitable for the proposed environment. For automatic sprinklers, the ENT coating is applied to all exposed exterior surfaces, including the waterway.
6. Allows installation from the floor by attaching a length of 1" diameter CPVC tubing to the tool. Ideal for sprinkler cabinets. Refer to Bulletin F_051808.

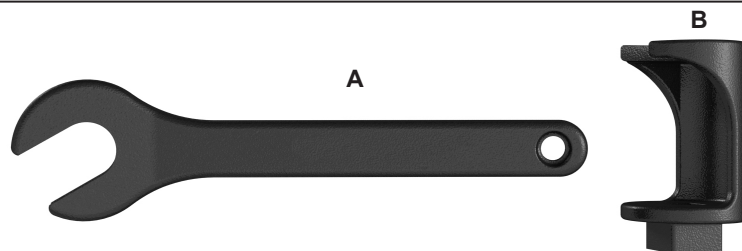

Figure 1: Sprinkler Wrenches



TECHNICAL DATA

FREEDOM® RESIDENTIAL HORIZONTAL SIDEWALL SPRINKLER VK460 (K5.8)

The Viking Corporation, 210 N Industrial Park Drive, Hastings MI 49058
 Telephone: 269-945-9501 Technical Services: 877-384-5464 Fax: 269-818-1680 Email: techsvcs@vikingcorp.com
 Visit the Viking website for the latest edition of this technical data page. www.vikinggroupinc.com

Approval Chart
Viking VK460, 5.8 K-Factor Residential Horizontal Sidewall Sprinkler

For systems designed to NFPA 13D or NFPA 13R. For systems designed to NFPA 13, refer to the design criteria. For Ceiling types refer to current editions of NFPA 13, 13R or 13D.

Sprinkler Base Part Number ¹	SIN	NPT Thread Size		Nominal K-Factor		Maximum Water Working Pressure	Overall Length					
		Inches	mm	U.S.	metric ²		Inches		mm			
13933	VK460	1/2	15	5.8	83.6	175 psi (12 bar)	2-1/2		63.5			
Max. Coverage Area ³ Width X Length Ft. X Ft. (m X m)	Max. Spacing Ft. (m)	Ordinary Temp Rating (155 °F/68 °C)		Intermediate Temp Rating (175 °F/79 °C)		Top of Deflector to Ceiling	Installation Type	Listings and Approvals ⁴				Minimum Spacing Ft. (m)
		Flow ³ GPM (L/min)	Pressure ³ PSI (bar)	Flow ³ GPM (L/min)	Pressure ³ PSI (bar)			C-UL-US-EU ⁵	VdS	NYC	NSF ⁸	
12 X 12 (3.7 X 3.7)	12 (3.7)	16 (60.6)	7.6 (0.52)	16 (60.6)	7.6 (0.52)	4 to 6 inches	Standard surface-mounted escutcheons or recessed with the Micromatic® Model E-1, E-2, or E-3 Recessed Escutcheon, or G-1 Adjustable Escutcheon	See Foot-note 7 and 10	See Foot-note 7	See Foot-note 6	See Foot-note 7	8 (2.4)
14 X 14 (4.3 X 4.3)	14 (4.3)	16 (60.6)	7.6 (0.52)	16 (60.6)	7.6 (0.52)							
16 X 16 (4.9 X 4.9)	16 (4.9)	20 (75.7)	11.9 (0.82)	21 (79.5)	13.1 (0.90)							
16 X 18 (4.9 X 5.5)	16 (4.9)	22 (83.3)	14.4 (0.99)	22 (83.3)	14.4 (0.99)							
16 X 20 (4.9 X 6.1)	16 (4.9)	26 (98.4)	20.1 (1.39)	26 (98.4)	20.1 (1.39)							
16 X 22 (4.9 X 6.7)	16 (4.9)	31 (117.3)	28.6 (1.97)	--	--							
18 X 18 (5.5 X 5.5)	18 (5.5)	23 (87.1)	15.7 (1.1)	23 (87.1)	15.7 (1.1)							
18 X 20 (5.5 X 6.1)	18 (5.5)	29 (109.8)	25.0 (1.7)	29 (109.8)	25.0 (1.7)							
20 X 20 (6.1 X 6.1)	20 (6.1)	30 (113.6)	26.8 (1.8)	30 (113.6)	26.8 (1.8)							
16 X 24 (4.9 X 7.3)	16 (4.9)	38 (143.8)	42.9 (2.96)	--	--							
14 X 26 (4.3 X 7.9)	14 (4.3)	42 (159)	52.4 (3.62)	--	--	6 to 12 inches	Standard surface-mounted escutcheons only	See Foot-note 7 and 10	See Foot-note 7	See Foot-note 6	See Foot-note 7	
12 X 12 (3.7 X 3.7)	12 (3.7)	16 (60.6)	7.6 (0.52)	16 (60.6)	7.6 (0.52)							
14 X 14 (4.3 X 4.3)	14 (4.3)	18 (68.1)	9.7 (0.67)	18 (68.1)	9.7 (0.67)							
16 X 16 (4.9 X 4.9)	16 (4.9)	24 (90.8)	17.1 (1.2)	24 (90.8)	17.1 (1.2)							
16 X 18 (4.9 X 5.5)	16 (4.9)	27 (102.2)	21.7 (1.49)	27 (102.2)	21.7 (1.49)							
16 X 20 (4.9 X 6.1)	16 (4.9)	32 (121.1)	30.4 (2.1)	32 (121.1)	30.4 (2.1)							
16 X 22 (4.9 X 6.7)	16 (4.9)	37 (140.1)	40.7 (2.81)	--	--							
18 X 18 (5.5 X 5.5)	18 (5.5)	29 (109.8)	25.0 (1.7)	29 (109.8)	25.0 (1.7)							
18 X 20 (5.5 X 6.1)	18 (5.5)	35 (132.5)	36.4 (2.51)	35 (132.5)	36.4 (2.51)							
20 X 20 (6.1 X 6.1)	20 (6.1)	36 (136.3)	38.5 (2.66)	36 (136.3)	38.5 (2.66)							
16 X 24 (4.9 X 7.3)	16 (4.9)	42 (159)	52.4 (3.62)	--	--							
14 X 26 (4.3 X 7.9)	14 (4.3)	46 (174.1)	62.9 (4.34)	--	--	6 to 12 inches	Standard surface-mounted escutcheons only	See Foot-note 7 and 10	See Foot-note 7	See Foot-note 6	See Foot-note 7	

Footnotes

- Part number shown is the base part number. For complete part number, refer to Viking's current price schedule.
- Metric K-factor measurement shown is when pressure is measured in Bar. When pressure is measured in kPa, divide the metric K-factor shown by 10.0.
- For areas of coverage smaller than shown, use the "Flow" and "Pressure" for the next larger area listed. Flows and pressures listed are per sprinkler. The distance from sprinklers to walls shall not exceed one-half the sprinkler spacing indicated for the minimum "Flow" and "Pressure" used.
- This chart shows the listings and approvals available at the time of printing. Other approvals may be in process. Check with the manufacturer for any additional approvals. Refer also to Design Criteria.
- Listed by Underwriter's Laboratories, Inc. for use in the U.S., Canada, and European Union.
- Meets New York City requirements, effective July 1, 2008.
- Approved Finishes are: Brass, Chrome, White Polyester, and Black Polyester ⁹
- UL Classified to : NSF/ANSI Standard 61, Drinking Water System Components (MH48034)
- Other paint colors are available on request with the same C-UL-US-EU listings as the standard finish colors.
- Approved finish is Electroless Nickel PTFE (ENT). ENT is C-UL-US-EU Listed as corrosion resistant. ENT is available with standard surface-mounted escutcheons or the Micromatic Model E-1 Recessed Escutcheon.



TECHNICAL DATA

FREEDOM® RESIDENTIAL HORIZONTAL SIDEWALL SPRINKLER VK460 (K5.8)

The Viking Corporation, 210 N Industrial Park Drive, Hastings MI 49058

Telephone: 269-945-9501 Technical Services: 877-384-5464 Fax: 269-818-1680 Email: techsvcs@vikingcorp.com

Visit the Viking website for the latest edition of this technical data page. www.vikinggroupinc.com

DESIGN CRITERIA

(Also refer to the Approval Chart.)

UL Listing Requirements (C-UL-US-EU):

When using Viking Residential Sprinkler VK460 for systems designed to NFPA 13D or NFPA 13R, apply the listed areas of coverage and minimum water supply requirements shown in the Approval Chart.

For systems designed to NFPA 13: The number of design sprinklers is to be the four contiguous most hydraulically demanding sprinklers. The minimum required discharge from each of the four sprinklers is to be the greater of the following:

- The flow rates given in the Approval Chart for NFPA 13D and NFPA13R applications for each listed area of coverage, or
- Calculated based on a minimum discharge of 0.1 gpm/sq. ft. over the "design area" in accordance with sections 8.5.2.1 or 8.6.2.1.2 of NFPA 13.
- Minimum distance between residential sprinklers: 8 ft. (2.4 m).
- The VK460 horizontal sidewall sprinkler deflector shall be located a minimum of 1-3/8" (35 mm) and a maximum of 6" (152 mm) from the wall on which it is installed.

DEFLECTOR POSITION: Install sprinkler VK460 with the leading edge of the deflector oriented parallel to the ceiling and the sprinkler frame arms oriented perpendicular to the ceiling (see Figure 3). **THE TOP SURFACE OF THE DEFLECTOR IS MARKED "TOP"**. The sprinkler must be oriented as shown in Figure 3.

IMPORTANT: Always refer to Bulletin Form No. F_091699 - Care and Handling of Sprinklers. Also refer to Forms F_080415, F_080814, and F_080190 for general care, installation, and maintenance information. Viking sprinklers are to be installed in accordance with the latest edition of Viking technical data, the appropriate standards of NFPA, VdS, and any other similar Authorities Having Jurisdiction, and also with the provisions of governmental codes, ordinances, and standards, whenever applicable. Final approval and acceptance of all residential sprinkler installations must be obtained from the Authorities Having Jurisdiction.

Step 1: Carefully slide the wrench sideways around the deflector, ensuring engagement with the sprinkler wrench flats.

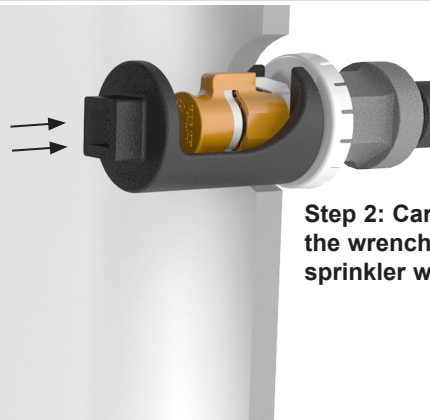
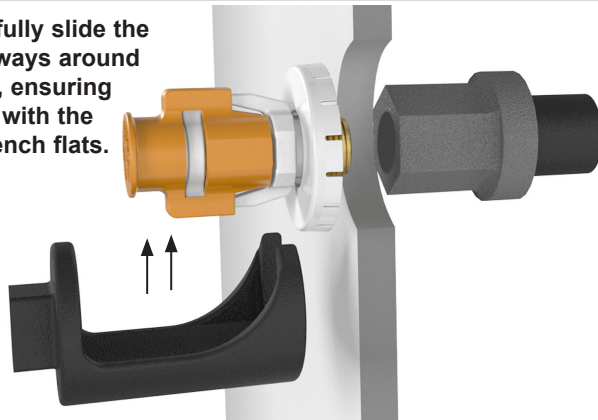

Step 2: Carefully press the wrench onto the sprinkler wrench flats.

Figure 2: Recessed Sprinkler Installation

** A 1/2" ratchet is required which is not available from us.



TECHNICAL DATA

**FREEDOM® RESIDENTIAL
HORIZONTAL SIDEWALL
SPRINKLER VK460 (K5.8)**

The Viking Corporation, 210 N Industrial Park Drive, Hastings MI 49058
 Telephone: 269-945-9501 Technical Services: 877-384-5464 Fax: 269-818-1680 Email: techsvcs@vikingcorp.com
 Visit the Viking website for the latest edition of this technical data page. www.vikinggroupinc.com

Wall Opening Size (A): Minimum 2-5/16" (59 mm) Maximum 2-1/2" (64 mm)

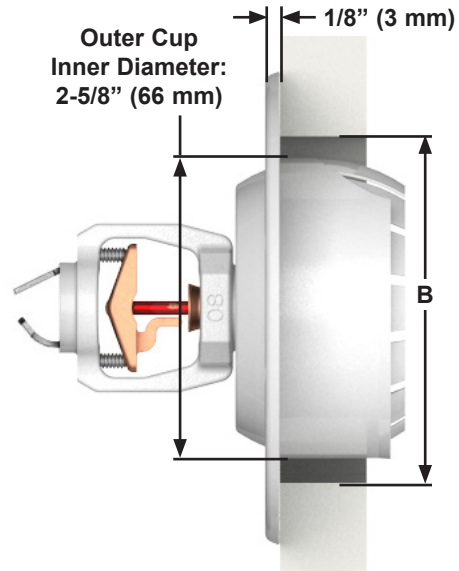
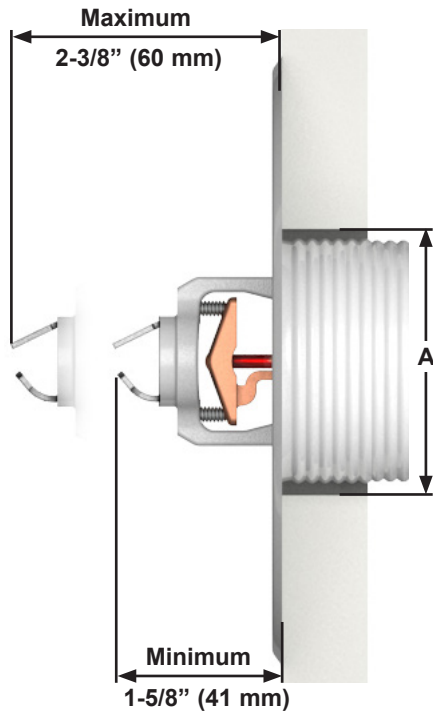
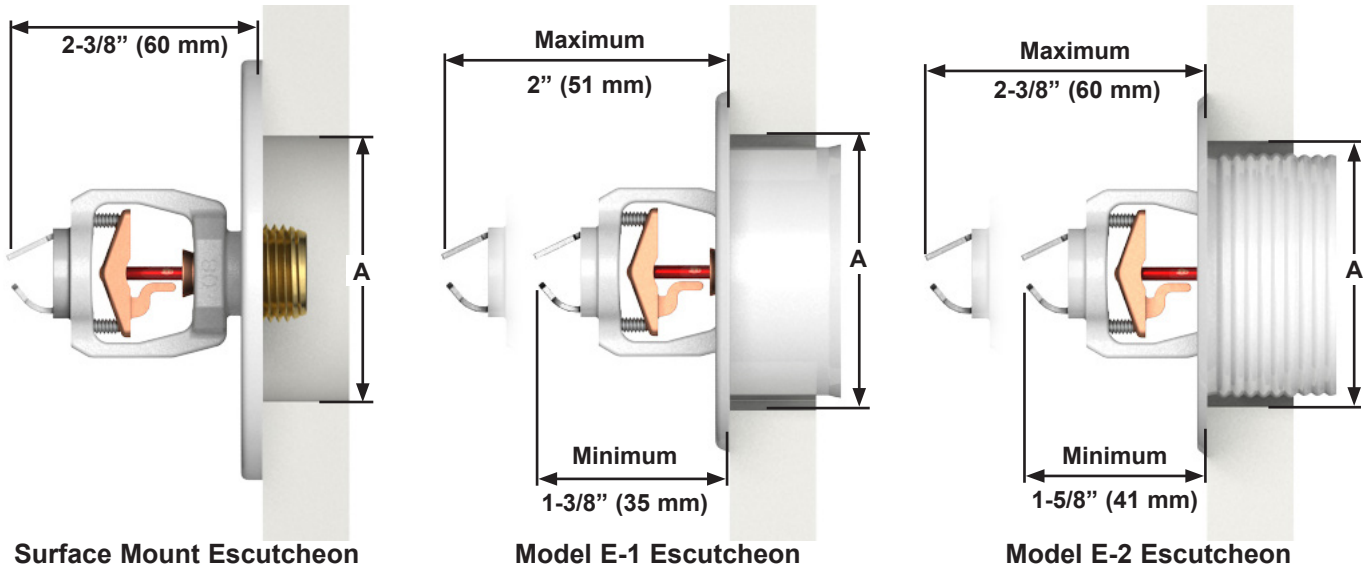

Figure 3: Installation Dimensions with Escutcheons



TECHNICAL DATA

**FREEDOM® RESIDENTIAL
HORIZONTAL SIDEWALL
SPRINKLER VK460 (K5.8)**

The Viking Corporation, 210 N Industrial Park Drive, Hastings MI 49058
Telephone: 269-945-9501 Technical Services: 877-384-5464 Fax: 269-818-1680 Email: techsvcs@vikingcorp.com
Visit the Viking website for the latest edition of this technical data page. www.vikinggroupinc.com

