



TECHNICAL DATA

MODEL A-3
PILOT OPERATED PRESSURE
REGULATING VALVE
ANGLE STYLE HALAR® COATED VALVE

The Viking Corporation, 210 N Industrial Park Drive, Hastings MI 49058

Telephone: 269-945-9501 Technical Services: 877-384-5464 Fax: 269-818-1680 Email: techsvcs@vikingcorp.com

1. DESCRIPTION

Model A-3 Pilot Operated Pressure Control Valves are factory assembled units. Each unit consists of a Model H-2 Halar® coated Flow Control Valve, a Speed Control Valve, a Model C-2 Pilot Pressure Regulating Valve, and all the necessary trim. The Pilot Operated Pressure Control Valve is for use on wet sprinkler systems where it is necessary to reduce a higher inlet pressure to a lower delivery pressure and automatically maintain that pressure within a close limit, regardless of fluctuations in the higher pressure inlet line.

The Viking Pilot Operated Pressure Control Valves must be installed in accordance with local Authorities Having Jurisdiction, and Viking Technical Data referenced below.

Viking Pilot Operated Pressure Control Valves are to be installed in accordance with the *Standard for the Installation of Sprinkler Systems* (NFPA 13). Viking Pilot Operated Pressure Control Valves are to be tested after installation in accordance with NFPA 13. Viking Pilot Operated Pressure Control Valves are to be inspected, tested and maintained in accordance with the *Standard for the Inspection, Testing and Maintenance of Water-Based Fire Protection Systems* (NFPA 25). Standard wet system riser equipment such as a Viking Check Valve, or Alarm Check Valve with appropriate trim and alarm attachments, are required (refer to Figure 1). Viking Pilot Operated Pressure Control Valve replacement parts are interchangeable.

2. LISTINGS AND APPROVALS



UL Listed: VLMT

3. TECHNICAL DATA

Specifications:

Maximum Working Water Pressure - 4" (DN100) - 175 PSI (12.1 bar)
 4" (DN100) - 250 PSI (17.2 bar) for Open Head Deluge Systems only
 6" (DN150) - 175 PSI (12.1 bar)
 6" (DN150) - 250 PSI (17.2 bar) for Open Head Deluge Systems only

Hydrostatically tested to - 500 PSI (34.2 bar)

Color of Valve - Red

Factory Setting - 80 psi (5.5 bar)

Material Standards:

Model H-2 Flow Control Valve - Refer to Technical Data Sheet [F_051700](#)

Model C-2 Pilot Pressure Regulating Valve - Refer to Technical Data Sheet [F_100799](#)

Model A-1 Speed Control Assembly - Refer to Technical Data Sheet [F_091794](#)

Ordering Information:

Refer to Table 1.

Accessories:

A Viking Check Valve or Alarm Check Valve with appropriate trim and alarm attachments are required. Order separately (refer to Fig. 1).

Viking Technical Data may be found on The Viking Corporation's Web site at <http://www.vikinggroupinc.com>. The Web site may include a more recent edition of this Technical Data Page.

Table 1 - Specifications

| Valve Size | Inlet Type | Outlet Type | Pipe O.D. Actual | Flange Drilling | Listings & Approvals | Friction Loss* | Shipping Weight | Model A-3 Part No. (Brass Trim) |
|------------|------------|-------------|---|---------------------------|----------------------|-----------------|---------------------|---------------------------------|
| 4" (DN100) | Flange | Groove | 4- ¹ / ₂ in. (114 mm) | ANSI B16.42 Class 150 | UL | 21 ft. (6.4 m) | 142 lbs. (64.4) | 10802 |
| 4" (DN100) | Flange | Flange | 4- ¹ / ₂ in. (114 mm) | ANSI B16.42 Class 150 | UL | 21 ft. (6.4 m) | 153 lbs. (69.4 kg) | 10803 |
| 4" (DN100) | Flange | Flange | 4- ¹ / ₂ in. (114 mm) | DIN 2501/BS 4504 PN 10/16 | UL | 21 ft. (6.4 m) | 153 lbs. (69.4 kg) | 10803 FFPN10/16 |
| 6" (DN150) | Flange | Groove | 6- ⁵ / ₈ in. (168 mm) | ANSI B16.42 Class 150 | UL | 39 ft. (11.9 m) | 266 lbs. (107.1 kg) | 11475 |
| 6" (DN150) | Flange | Flange | 6- ⁵ / ₈ in. (168 mm) | ANSI B16.42 Class 150 | UL | 39 ft. (11.9 m) | 266 lbs. (107.1 kg) | 11476 |
| 6" (DN150) | Flange | Flange | 6- ¹ / ₂ in. (165.1 mm) | DIN 2501/BS 4504 PN 10/16 | UL | 39 ft. (11.9 m) | 281 lbs. (125.5 kg) | 11476 FFPN10/16 |

* Friction loss values are provided in equivalent length of pipe based on Hazen & Williams formula C = 120, and are for the Pilot Operated Pressure Control Valve only. They DO NOT include friction loss for additional wet system riser equipment such as a Viking Check Valve or Alarm Check Valve.



TECHNICAL DATA

MODEL A-3
PILOT OPERATED PRESSURE
REGULATING VALVE
ANGLE STYLE HALAR® COATED VALVE

The Viking Corporation, 210 N Industrial Park Drive, Hastings MI 49058

Telephone: 269-945-9501 Technical Services: 877-384-5464 Fax: 269-818-1680 Email: techsvcs@vikingcorp.com

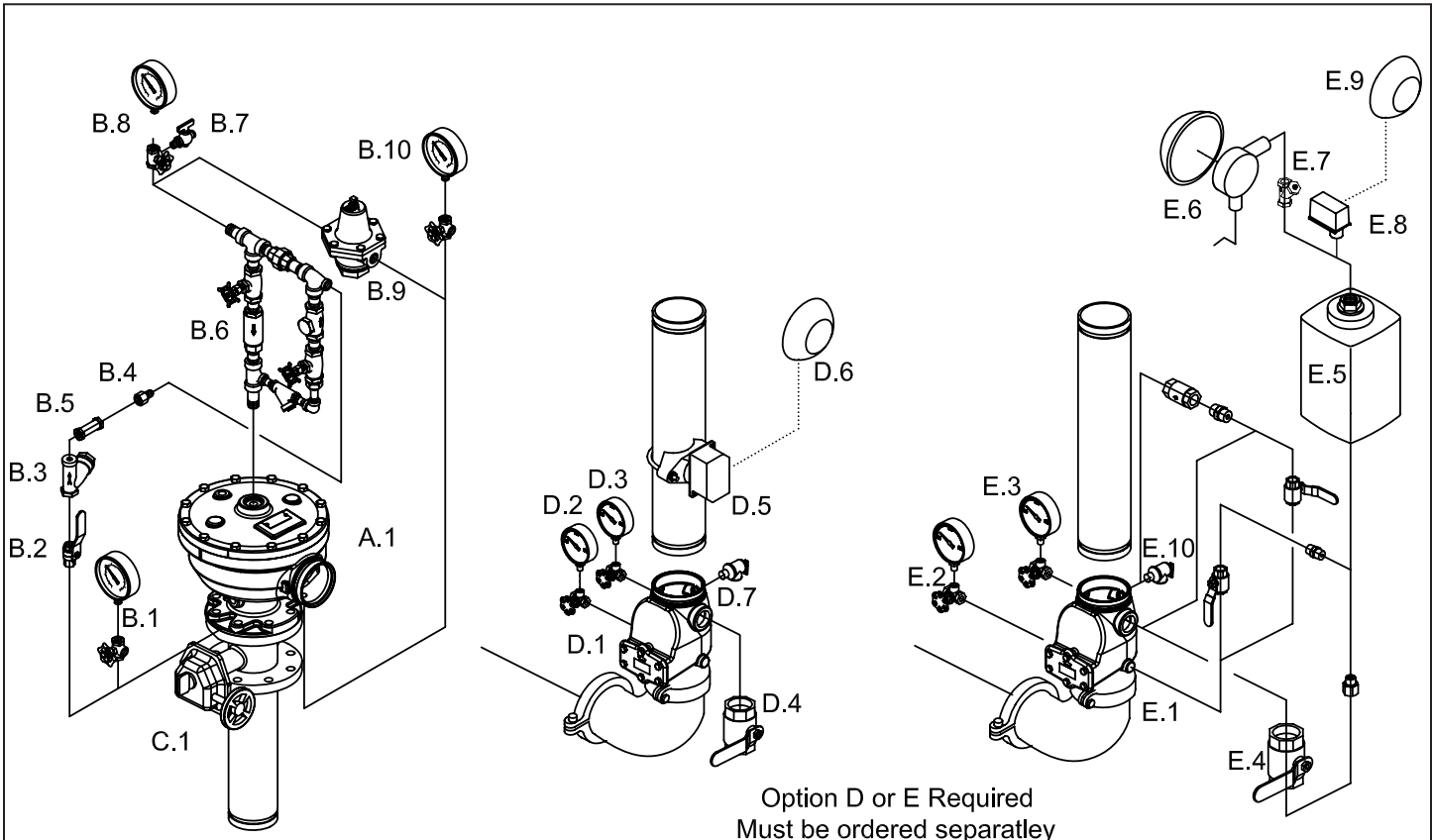

A. Valve

A.1 Viking Flow Control Valve

B. Trim

B.1 Water Supply Pressure Gauge and Valve

B.2 Priming Valve (Normally Open)

B.3 Strainer

B.4 1/8" Restriction

B.5 Spring Loaded Check Valve

B.6 Viking Speed Control Valve

B.7 Air Bleed-Off Valve (Normally Closed)

B.8 Water Pressure Gauge and Valve

B.9 Viking Model C-2 Pilot Pressure Regulating Valve

B.10 Outlet Pressure Gauge and Valve

C. Water Supply

C.1 Water Supply Control Valve

D. Check Valve and Flow Switch Option

D.1 Easy Riser Check Valve (or rubber seated check valve)

(Grooved Valve shown for clarity)

D.2 Supply Water Pressure Gauge and Valve

D.3 System Water Pressure Gauge and Valve

D.4 System Main Drain Valve

D.5 Waterflow Switch

D.6 Electric Alarm Bell

D.7 Pressure Relief Valve

E. Alarm Check Valve and Water Motor Alarm Option

E.1 Viking Alarm Check Valve (Grooved Valve shown for clarity)

E.2 Supply Water Pressure Gauge and Valve

E.3 System Water Pressure Gauge and Valve

E.4 Vertical Alarm Valve Trim Includes Main Drain Valve F.5 Retard Chamber

E.5 Water Motor Alarm (Strainer Required) and Alarm Gong

E.6 3/4" (20 mm) Strainer

E.7 Alarm Pressure Switch.

E.8 Electric Alarm Bell

E.9 Pressure Relief Valve

Order Water Supply Control Valve and components listed for Riser Equipment, Check Valve and Flow Switch option and Alarm Check Valve or Water Motor Alarm equipment separately.

Figure 1 - System Components



TECHNICAL DATA

MODEL A-3
PILOT OPERATED PRESSURE
REGULATING VALVE
ANGLE STYLE HALAR® COATED VALVE

The Viking Corporation, 210 N Industrial Park Drive, Hastings MI 49058

Telephone: 269-945-9501 Technical Services: 877-384-5464 Fax: 269-818-1680 Email: techsvcs@vikingcorp.com

4. INSTALLATION

A. General Installation Instructions

The Model A Pilot Operated Pressure Control Valve must be installed in the upright position only. The assembly must be installed in an area not subject to freezing temperatures or physical damage. When corrosive atmospheres and/or contaminated water supplies are present, it is the owner's responsibility to verify compatibility with the Pilot Operated Pressure Control Valve and associated equipment.

B. Inlet/Outlet Pressures

The difference between the water supply pressure and the desired outlet (downstream) pressure should be greater than 20 PSI (1.4 bar) to maintain accurate control of discharge pressure. Refer to the Cavitation and Operating Chart in the Technical Data page describing the Viking Model C-2 Pilot Pressure Regulating Valve for proper operating range of pressure reduction and flow. To accomplish large pressure reductions indicated by the shaded portion of the Cavitation and Operating Chart, and avoid cavitation, pressure reduction should be taken in two stages using two Pilot Operated Pressure Regulating Valves arranged in series as shown in Figure 2. For pressures above 175 PSI (12 bar), the heavy spring (P/N 09200) must be used.

⚠ CAUTION

Due to the flow regulating characteristic of this device, its impact on system hydraulics should be carefully considered, especially when retrofitted onto existing systems.

C. Regulating Spring Options

The Model C-2 Pilot Pressure Regulating Valve is factory assembled and shipped with a regulating spring for use where the desired discharge pressure is 80 to 150 psi (5.5 to 10.3 bar). If the desired discharge pressure is below that range, the factory-installed spring must be removed and the appropriate regulating spring installed. For regulating spring pressure range options, part numbers, identification and replacement instructions, see Technical Data Sheet [F_100799](#) describing the Viking Model C-2 Pilot Pressure Regulating Valve.

D. Trim

The factory-connected priming line is supplied from the inlet chamber of the flow control valve. All water released from the priming chamber of the flow control valve must pass through the pilot pressure regulating valve for regulation to occur. For proper operation and approval, DO NOT modify the factory-installed trim arrangement. Wet system riser components, including a listed check valve or alarm check valve with appropriate trim and alarm devices, must be connected to the outlet of the pilot operated pressure control valve (refer to Figure 1). Install all components according to current technical data and trim charts for the equipment used.

E. Hydrostatic Testing

When performing hydrostatic testing for system acceptance purposes, comply with recommendations set forth in the Installation Standards.

F. Placing the Valve in Service

(Refer to Figure 1.)

1. Verify that the pilot operated pressure control valve is trimmed according to current Viking schematic drawings (refer to Figure 1) and that all riser components and alarm devices have been installed and tested according to current technical data and trim charts.
2. Verify that the pilot pressure regulating valve is equipped with the regulating spring appropriate for the desired downstream pressure.
3. Verify that auxiliary drains are closed and the system is free of leaks.
4. Open the system (inspector's) test valve, and any auxiliary vents provided to facilitate removal of air from the system to allow air to escape from the system while it is filling with water.
5. Open the priming valve (B.2) to pressurize the priming chamber with water supply pressure.
6. Slowly open the water supply main control valve (C.1).
7. Allow the system to completely fill with water. Allow water to flow from the system test valve, and any other open vents provided, until all air is exhausted from the system.

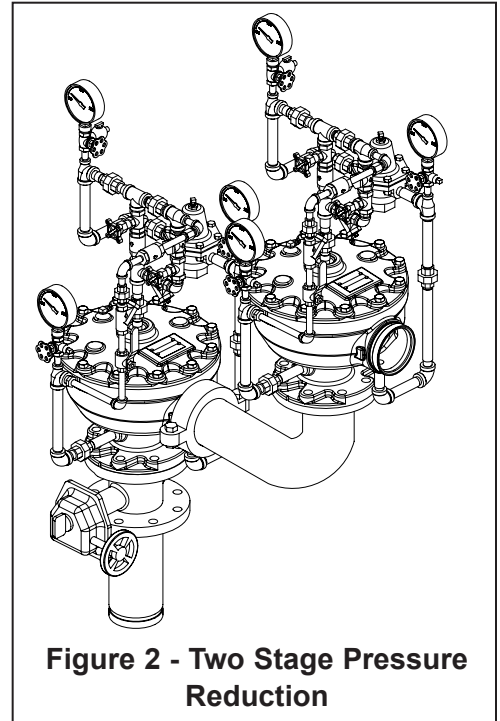

Figure 2 - Two Stage Pressure Reduction



TECHNICAL DATA

MODEL A-3
PILOT OPERATED PRESSURE
REGULATING VALVE
ANGLE STYLE HALAR® COATED VALVE

The Viking Corporation, 210 N Industrial Park Drive, Hastings MI 49058

Telephone: 269-945-9501 Technical Services: 877-384-5464 Fax: 269-818-1680 Email: techsvcs@vikingcorp.com

8. After all air is exhausted from the system, close the system test valve and all other open vents.
9. To ensure smooth regulation, all air must be removed from the priming chamber of the flow control valve.
 - a. Temporarily open the air bleed-off valve (B.7) (water will flow from the opening).
 - b. Close the bleed-off valve after air is expelled.
10. Secure all valves in their normal operating position.
11. Notify the Authority Having Jurisdiction, remote station alarm monitors, and those in the affected area that the system is in service.

Verify Downstream Pressure Setting:

It is recommended that the desired discharge pressure of the system be tested (and when necessary, adjusted) with a minimum flow of 25 GPM (95 LPM) or greater flowing through the flow control valve. The system main drain valve (D.4 or E.4), located downstream from the clapper of the check valve on the system riser, can be used for this purpose.

12. OPEN the main drain (D.4 or E.4) located downstream from the check valve in the system riser.
13. Establish a minimum flow of 25 GPM (95 LPM) or greater and observe the downstream pressure gauge.
14. If a surging flow occurs, repeat step 9 above. If surging continues, adjust speed control assembly or speed control valve (B.6). If necessary, refer to adjustment instructions provided in current Technical Data describing the Viking Pilot Pressure Regulating Valve.
15. If adjustment of the speed control assembly is necessary, refer to adjustment instructions printed in current Technical Data describing the Viking Speed Control Assembly. If adjustment of the speed control valve is necessary, closing the valve will slow the surges.
16. CLOSE the system main drain (D.4 or E.4) opened in step 12 above.

NOTE: THE PRESSURE GAUGE INSTALLED ON OUTLET PIPING FROM THE PILOT PRESSURE REGULATING VALVE MAY INDICATE STATIC PRESSURE HIGHER THAN 50 PSI (3.4 BAR) ABOVE THE OUTLET "SET" PRESSURE DETERMINED ABOVE. THIS IS DUE TO CHANGES IN FLOW VELOCITY THAT MAY OCCUR WHEN FLOW THROUGH THE SYSTEM IS STOPPED. ACTUAL "SET" PRESSURE SHOULD NOT BE AFFECTED.

17. Record "set" pressure in the space provided on the regulating spring identification tag provided.
18. Verify:
 - a. The water supply main control valve (C.1) is fully OPEN and properly locked or supervised.
 - b. The priming valve (B.2) is fully OPEN and secure.
 - c. If an alarm valve and trim are provided, the alarm test valve is in the normal (ALARM) position (see trim chart).
 - d. Alarms are operational and in service.
 - e. All other valves are in their normal operating position and secure.
 - f. Equipment is adequately heated and protected to prevent freezing and physical damage.

5. OPERATION

System water supply pressure from the inlet chamber of the flow control valve enters the flow control valve priming chamber through the factory installed priming line and speed control. The speed control allows flow into and out of the priming chamber. The speed control also allows flow out of the priming chamber and into the Model C-2 Pilot Pressure Regulating Valve. Flow through the Model C-2 Pilot Pressure Regulating Valve is controlled by a regulating spring, which is field adjustable to the desired downstream pressure to be maintained. A sensing line connects the system piping downstream of flow control valve, to the outlet chamber of the pilot pressure regulating valve. When downstream pressure rises above the set point of spring, flow through the pilot pressure regulating valve is stopped. When downstream pressure falls below the set point of spring, flow through the valve resumes. The regulated flow through the pilot pressure regulating valve controls the pressure in the priming chamber of the flow control valve to open or close the flow control valve clapper as required to regulate downstream system pressure.

6. INSPECTIONS, TESTS AND MAINTENANCE

NOTE: VALVES ARE TO BE SET TO PROVIDE OUTLET PRESSURES AND FLOWS, AND ARE TO BE TESTED AFTER INSTALLATION IN ACCORDANCE WITH NFPA 13, AND TESTED PERIODICALLY THEREAFTER IN ACCORDANCE WITH NFPA 25.

NOTICE

The owner is responsible for maintaining the fire protection system and devices in proper operating condition. The Pilot Operated Pressure Control Valve must be kept from freezing conditions and physical damage that could impair its operation.

WARNING

Any system maintenance that involves placing a control valve or detection system out of service may eliminate the fire protection capabilities of that system. Prior to proceeding, notify all Authorities Having Jurisdiction. Consideration should be given to employment of a fire patrol in the affected areas.



TECHNICAL DATA

MODEL A-3
PILOT OPERATED PRESSURE
REGULATING VALVE
ANGLE STYLE HALAR® COATED VALVE

The Viking Corporation, 210 N Industrial Park Drive, Hastings MI 49058

Telephone: 269-945-9501 Technical Services: 877-384-5464 Fax: 269-818-1680 Email: techsvcs@vikingcorp.com

It is imperative that the system is inspected and tested on a regular basis. The frequency of the inspections may vary due to contaminated water supplies, corrosive water supplies, or corrosive atmospheres. Also, the alarm devices, detection systems, or other connected trim may require a more frequent schedule. For minimum maintenance and inspection requirements, refer to NFPA 25, which describes care and maintenance of sprinkler systems. In addition, the Authority Having Jurisdiction may have additional maintenance, testing, and inspection requirements that must be followed.

The following recommendations are minimum requirements for inspection, testing, and maintenance of the Viking Pilot Operated Pressure Control Valve. For minimum maintenance, testing, and inspection requirements for Viking Check Valves, Alarm Check Valves, associated trim and alarm attachments, refer to current Technical Data for the equipment used.

I. Inspection

A. Monthly

Monthly visual external inspection of the pilot operated pressure control valve assembly is recommended.

1. Verify that pressure gauges indicate normal water supply pressures.

NOTE: THE PRESSURE GAUGE INSTALLED ON OUTLET PIPING FROM THE PILOT PRESSURE REGULATING VALVE (B.10) MAY INDICATE STATIC PRESSURE APPROXIMATELY 8 TO 10 PSIG HIGHER THAN THE OUTLET "SET" PRESSURE DETERMINED ABOVE. THIS IS DUE TO CHANGES IN FLOW VELOCITY THAT MAY OCCUR WHEN FLOW THROUGH THE SYSTEM IS STOPPED. ACTUAL "SET" PRESSURE SHOULD NOT BE AFFECTED.

2. Verify that the water supply main control valve is open and all valves are in their normal operating position and appropriately secured.
3. Check for signs of mechanical damage, leakage, and/or corrosive activity. If detected, perform maintenance as required. If necessary, replace the device.
4. Verify that valve and trim are adequately heated and protected from freezing and physical damage.

II. Tests

A. Quarterly

Quarterly testing of water flow alarms and performance of a Main Drain Test is recommended and may be required by the Authority Having Jurisdiction. Refer to current Technical Data describing the Viking Alarm Check Valve, trim, and/or alarm attachments used.

B. Annually

Annually, it is recommended that the desired discharge pressure of the system be tested (and when necessary, adjusted) with a minimum flow of 25 GPM (95 LPM) or greater flowing through the Flow Control Valve.

1. Perform steps 13 through 16 of paragraph 4.F - PLACING THE VALVE IN SERVICE.
2. Compare pressure and flow performance with original installation and/or acceptance tests. If changes are detected, take appropriate steps to establish the desired downstream pressure and flow.
3. Record and/or provide notification of test results as required by the Authority Having Jurisdiction.

C. Every Fifth Year

1. Internal inspection of flow control valves is recommended every five years unless inspections and tests indicate more frequent internal inspections are required. Refer to Technical Data describing the Viking Flow Control Valve.
2. Internal inspection of strainers, restricted orifices, and diaphragm chambers is recommended every five years unless inspections and tests indicate more frequent internal inspections are required. For strainer disassembly and maintenance instructions, refer to Technical Data describing the Viking Pilot Pressure Regulating Valve and/or the Viking Speed Control Assembly.
3. Record and provide notification of inspection results as required by the Authority Having Jurisdiction.

D. After Each Operation

Sprinkler systems that have been subjected to a fire must be returned to service as soon as possible. The entire system must be inspected for damage, and repaired or replaced as necessary.

III. Maintenance

Model H-2 Flow Control Valve - Refer to Technical Data Sheet [F_051700](#)

Model C-2 Pilot Pressure Regulating Valve - Refer to Technical Data Sheet [F_100799](#)

Model A-1 Speed Control Assembly - Refer to Technical Data Sheet [F_091794](#)

7. AVAILABILITY

The Manual Pull Station is available through a network of domestic and international distributors. See the Viking Web site for closest distributor or contact The Viking Corporation.

8. GUARANTEES

For details of warranty, refer to Viking's current list price schedule or contact Viking directly.



TECHNICAL DATA

MODEL A-3
PILOT OPERATED PRESSURE
REGULATING VALVE
ANGLE STYLE HALAR® COATED VALVE

The Viking Corporation, 210 N Industrial Park Drive, Hastings MI 49058

Telephone: 269-945-9501 Technical Services: 877-384-5464 Fax: 269-818-1680 Email: techsvcs@vikingcorp.com

Figure 3 - Installation Dimensions

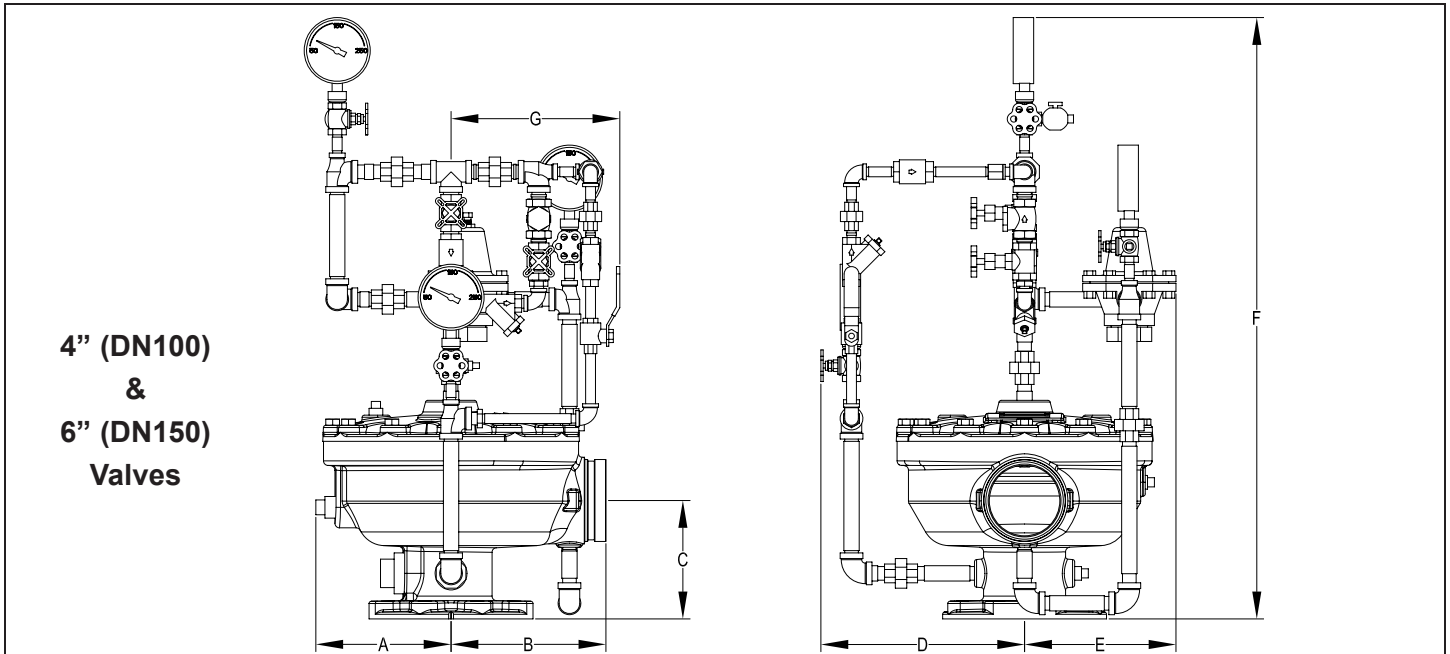

| Valve Size | A | B | C | D | E | F | G |
|-------------------|---------------------|--------------------|--------------------|----------------------|---------------------|----------------------|-----------------------|
| 4" (DN100) | 7-7/16" (189 mm) | 8-1/2" (216 mm) | 6-1/2" (165 mm) | 11-3/16" (284 mm) | 8-5/16" (211 mm) | 33" (839 mm) | 9-1/4" (235 mm) |
| 6" (DN150) | 9-1/8" (232 mm) | 12" (305 mm) | 8" (203 mm) | 11-3/8" (289 mm) | 9-1/8" (232 mm) | 34-5/16" (872 mm) | 11-13/16" (300 mm) |