



TECHNICAL DATA

OXEO SHUTTLE NON-RETURN VALVE

The Viking Corporation | 210 N Industrial Park Drive | Hastings MI 49058
 Viking Special Hazards | Technical Services: 877-384-5464 | Email: techsvcs@vikingcorp.com | www.vikinggroupinc.com
 The technical data described herein is for components of the Viking Oxeo PR Fire Extinguishing Systems.
 Visit the Viking website for the latest edition of the technical data and system manuals.

1. DESCRIPTION

The shuttle non-return valve is used for the pneumatic directional control of pneumatic systems with two different pressure sources. The shuttle non-return valve is used in stationary IG-01 and IG-100 fire extinguishing systems.

2. LISTINGS AND APPROVALS



cULus Listed - EX5248 (OxEO PR LCP)



FM Approved: OxEO PR LCP

3. TECHNICAL DATA

3.1 - Specifications and Ratings

Parameter	Value
Operating medium	Argon
	Nitrogen
Working pressure	29 to 2030 psi (2 to 140 bar)
Test pressure	3045 psi (210 bar)
Rate of pressure rise	Minimum 43.5 psi/sec (minimum 3 bar/sec)
Installation position	Feedings only horizontal
Material standards	
Housing	Aluminum
Gasket	NBR
Ball	Stainless steel

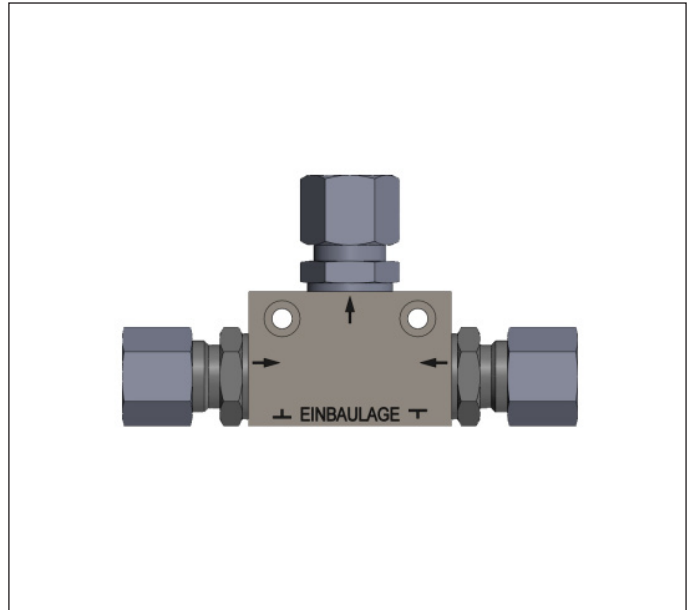

Designation	Part no.
Shuttle non-return valve	886247

WARNING: Cancer and Reproductive Harm-
www.P65Warnings.ca.gov

4. OPERATION

The operation of the shuttle non-return valve is triggered by the input of pneumatic pressure from one of two directions. Depending on the direction of the input pressure, the valve will operate in one of two ways:

When input "A" is pressurized, input "B" closes, creating a passage from input "A" to the output of the valve.

When input "B" is pressurized, input "A" closes, creating a passage from input "B" to the output of the valve.

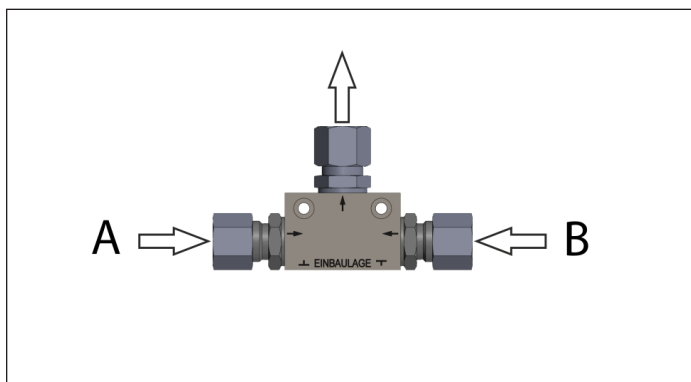

Figure 1: Operation

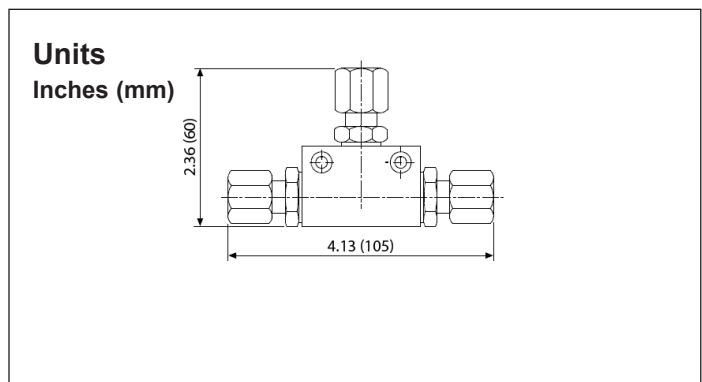

Figure 2: Dimensions

**TECHNICAL DATA****OXEO SHUTTLE NON-RETURN VALVE**

The Viking Corporation | 210 N Industrial Park Drive | Hastings MI 49058

Viking Special Hazards | Technical Services: 877-384-5464 | Email: techsvcs@vikingcorp.com | www.vikinggroupinc.com

The technical data described herein is for components of the Viking Oxeo PR Fire Extinguishing Systems.

Visit the Viking website for the latest edition of the technical data and system manuals.

5. INSTALLATION

Prior to installation the release pipes shall be checked for cleanliness and blown through with compressed air if necessary. Refer to Figure 3 for approved installation positions.

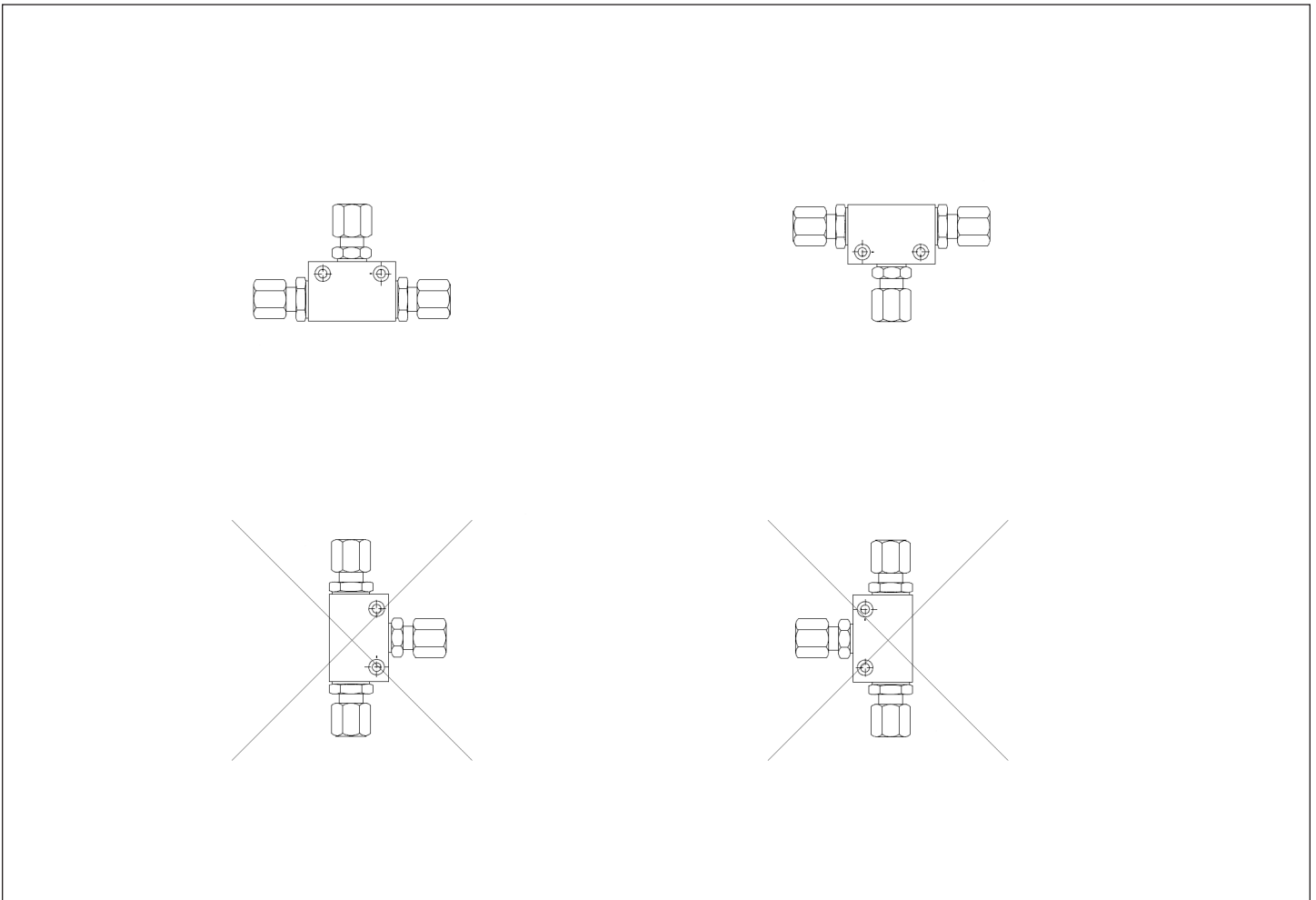

Figure 3: Installation positions