



Nitro G3

Fully Automated Fire Protection Nitrogen Generators for Dry Pipe Sprinkler Systems

General Air Products NGP-Series Nitrogen Generators are specifically designed to provide on-site, high purity nitrogen for use in dry and pre-action fire protection sprinkler systems. Each unit is a fully tested and assembled, turn-key package and includes all of the components needed to fill the sprinkler system to supervisory pressure within 30 minutes per NFPA 13. Our Nitrogen Generators are built to the highest quality standards – the same standards the fire sprinkler industry has come to expect from any product that carries the General Air Products logo.

General Air Products Nitro-G3 Nitrogen Generators are fully automated and operated via a simple to use touch screen interface. The automatic operation allows you to simply plug in the required settings and let the machine do all the work. The Nitro-G3 is also web enabled for off-site monitoring and email notifications making this the smartest, most efficient and dependable method of producing a minimum of 98% nitrogen at the point of usage. This will inhibit corrosion, improve the life of the system and lower maintenance costs. As always, all of our products are backed by the best lifetime customer service and technical support in the fire sprinkler industry.



- Turn-Key Design For Easy Installation
- One Power Connection - Plug & Play
- 98%+ Nitrogen Purity Standard
- Fire Protection Air Compressor
- Premium Nitrogen Membrane
- HMI Touch Screen Display
- Fully Automated For Simplified Operation
- Web Enabled For Off-Site Monitoring & Reports
- Email Connectivity - Alarm & Maintenance Notifications
- Lifetime Customer Service & Technical Support

Maintenance Capacity (gal)	Model Number	Fill Capacity		Compressor		Air Tank Size (gal)	N2 Tank Size (gal)
		40PSI in 30 min	20PSI in 30 min	Type	HP		
1275	NGP-G3-500	500 gal	1100 gal	Oil-Less	1	30	30
1275	NGP-G3-500Q	500 gal	1100 gal	QUIET Oil-Less	1	30	30
1275	NGP-G3-1000-M1	925 gal	2150 gal	Oil-Less	2	30	30
3880	NGP-G3-1000-M2	925 gal	2150 gal	Oil-Less	2	30	30
6500	NGP-G3-1000-M3	925 gal	2150 gal	Oil-Less	2	30	30
6500	NGP-G3-2200-M3	2350 gal	4100 gal	Lubricated	7.5	30	30
13000	NGP-G3-2200-M4	2350 gal	4100 gal	Lubricated	7.5	30	30
22000	NGP-G3-2200-M5	2350 gal	4100 gal	Lubricated	7.5	30	30

Fully Automated Fire Protection Nitrogen Generators

HMI Touch Screen

The Nitro-G3 is fully automated and operated by a simple to use touch screen interface. The touch screen display has video capabilities for assistance with maintenance procedures. Detailed parameters can be monitored, history reports can be viewed, system tests can be run and much more - all with the push of a button. The Nitro-G3 is simply the smartest, most advanced fire protection nitrogen generator designed for the sprinkler industry.



Fire Protection Air Compressor

ASME N2 & Air Storage Tanks

Premium Nitrogen Membrane

Smart Wire Technology

Fully Automated Valves

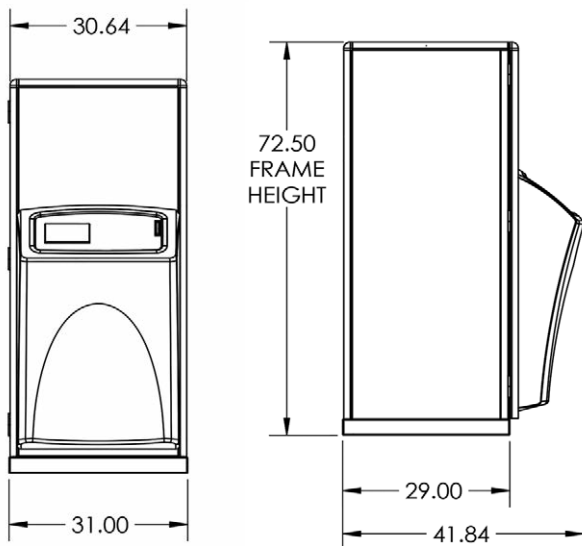

Accessories:



Air Maintenance Device

Required to regulate the volume of air being delivered to the system. Our AMDs are UL listed & FM approved.



Inspectors Gas Analyzer Port (iGAP)

Analyzer port to monitor and ensure high purity nitrogen is equally distributed throughout the fire sprinkler system.