

# FIRE VALVE

## Gate Valve OS&Y Flanged

- Design and dimensions conform to FM/UL and AWWA C515
- Flanged and Grooved to ANSI B16.1 Class 125
- Fusion bonded epoxy coated interior and exterior-AWWA C550
- Valve is rated at 300 PSI for Fire Protection Service
- Temperature Range : 0°C- 100°C

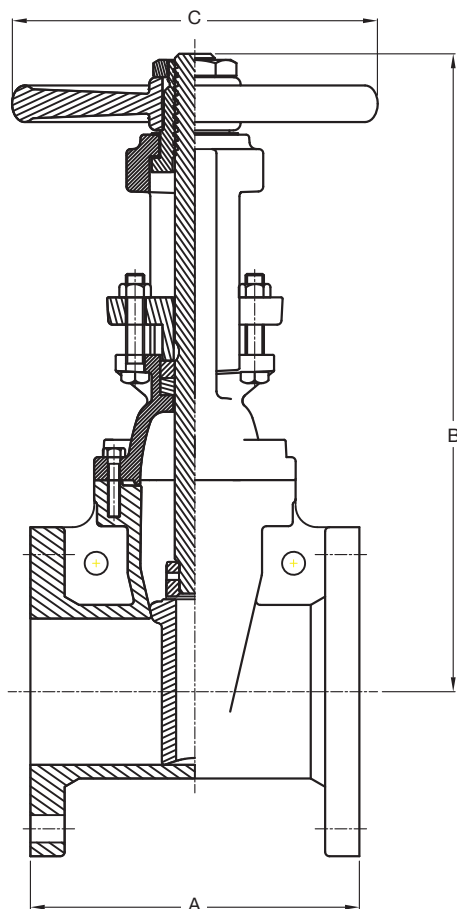

COMPONENTS	MATERIAL
Body	Ductile Iron ASTM A126 Class B
Wedge	Ductile Iron ASTM A126 Class B, EPDM Coated
Wedge Nut	Bronze ASTM B62 C83600
O-Ring	EPDM
Stem	Brass ASTM B16 C36000
Stem	Stainless Steel AISI 304
Gasket	EPDM
Bonnet	Ductile Iron ASTM A126 Class B
Washer	PTFE
Packing	Sq, Braided Non-Asbestos
Packing Gland	Ductile Iron ASTM A 126 Class B
Handwheel	Cast Iron ASTM A536 Gr. 65-45-12

VALVE SIZE	ITEM CODE	DIMENSION (IN)			
		A	B OPEN	B CLOSE	C
2-1/2"	UFP001	7.5"	15.5"	13"	7"
3"	UFP002	8"	19.5"	16"	8"
4"	UFP003	9"	21.75"	17.75"	10"
6"	UFP004	10.5"	29.5"	24.25"	12"
8"	UFP005	11.5"	37.25"	29"	14"
10"	UFP006	13"	44"	33.75"	16"
12"	UFP007	14"	52.25"	40"	18"