



# UNITED BRASS WORKS, INC.

714 S. Main St., Randleman, NC 27317

Tel: 800-334-3035 Fax: 800-498-4696 www.ubw.com



## Model 210 Swing Check Valve

200 WOG @ 180 ° Max

100% Pressure Tested • Integral Seat  
Threaded Ends • Metal Disc



*Swing Check Valve with 3/32" orifice in Clapper  
for use on automatic pressure switch line of fire pump  
installation as required by NFPA No. 20A-7-5.2.1.*

*Not Recommended for Pulsating or Vibrating Service!  
Install in horizontal position only!*

*\*Contains Lead. Not for Use in Potable Water Systems\**

### MATERIAL LIST

NO.	DESCRIPTION	MATERIAL
1	Cap (1/4" - 1") Cap (1/4" - 2")	Bronze Brass
2	Washer	Brass
3	Body	Bronze
4	Disc	Brass
5	Hinge	Stainless Steel

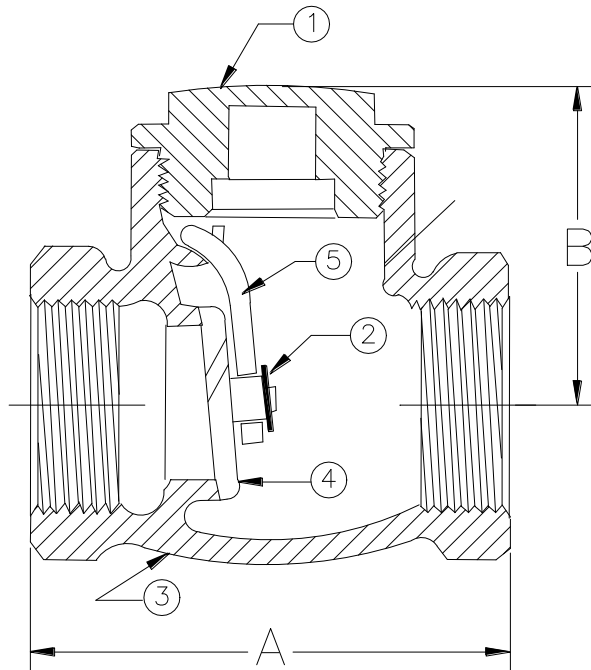

Size	1/4"	3/8"	1/2"	3/4"	1"	1 1/4"	1 1/2"	2"
A	1.89	1.89	2.14	2.51	3.03	3.45	3.81	4.44
B	1.22	1.22	1.28	1.53	2.06	2.20	2.20	2.86
Ship Wgt. (lbs.)	0.45	0.45	0.58	0.81	1.62	1.81	2.41	3.42
Qty. Unit Pack	12	12	12	12	6	6	4	2
Qty. Per Case	60	60	60	60	30	18	12	6