

ID.	QTY	PT NO.	DESCRIPTION
A	1	M050A5617TEFC	1/2 HP MOTOR
B	1	HTP055330	PUMP
C	1	BHTP05-9507	BASE
D	1	G-9518	HANDLE
E	1	RVBYMF12	RELIEF VALVE
F	1	BVMF12	1/2 BALL VALVE
G	1	LFSB30-2	PRESS GAUGE
H	1	HTP-01-79652	TOGGLE SW.
I	1	HTP-71803	BOOT
J	2	BM 90 1/2"	1/2 ELBOW
K	2	BM TEE 1/2"	1/2 TEE
L	7	BM 1/2 X CL	CLOSE NIPPLE
M	1	DVA-0008-1	POWER CORD
N	1	HTP05HA075	BYPASS HOSE
O	1	5AS-12D	HOSE CONNR.
P	1	BM T 1/2 X 1/4	REDUCING TEE
Q	1	BM 1/2 X 3	NIPPLE
R	1	HTP05HA10	OUTPUT HOSE
S	2	HTP4X1W1G339	4" WHEEL
T	1	DVA-0010-3	STRAIN RELIEF
U	2	HTPMPLEG05	SUPPORT LEG
V	2	S3748-8D	ADAPTER
W	1	BM 1/2	COUPLING
X	2	AVVECO-10394	HAIRPIN COTTER

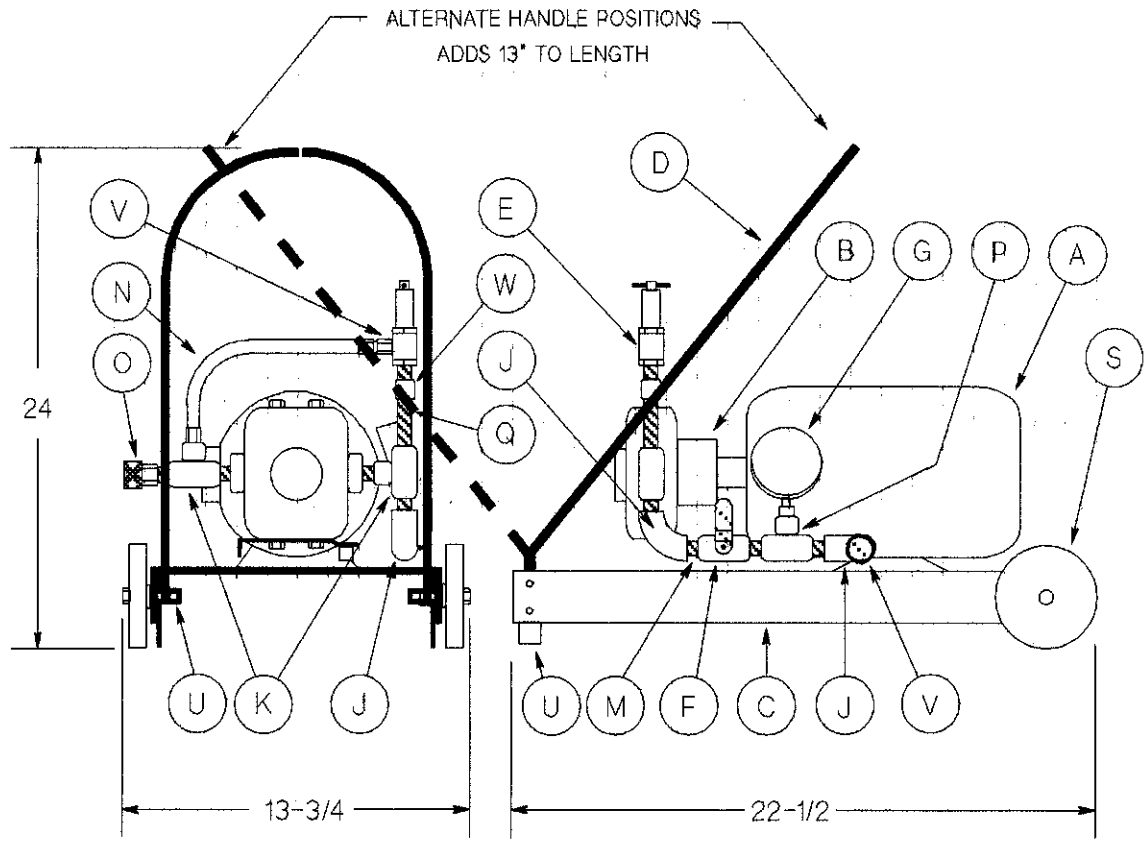

ADDITIONAL DRAWINGS		GENERAL AIR PRODUCTS	
G-9507	BASE	604 JEFFERS CIRCLE	EXTON, PA 19341
G-9518	HANDLE	SCALE: NONE	APPROVED BY:
G-9533	SUPPORT LEG	DATE: 4-12-00	DRAWN BY: T
		REV. 3	
HYDROSTATIC TEST PUMP ARRANGEMENT			
REV-3 10/30/02	MOTOR PART NUMBER WAS LISTED AS M075A5617TEFC	DWS. NO. G-9506	

NOT SHOWN - H, I, M, R, T & X HTP1-2AR